

TECHNICAL MANUAL
MAINTENANCE INSTRUCTIONS
ORGANIZATIONAL MAINTENANCE

M977 SERIES 8 x 8 HEAVY
EXPANDED MOBILITY
TACTICAL TRUCKS (HEMTT)

| MODEL | NSN |
|--|------------------|
| TRUCK, CARGO, WITH WINCH M977 | 2320-01-097-0260 |
| TRUCK, CARGO, WITHOUT WINCH M977 | 2320-01-099-6426 |
| TRUCK, TANK, FUEL, WITH WINCH M978 | 2320-01-097-0249 |
| TRUCK, TANK, FUEL, WITHOUT WINCH M978 | 2320-01-100-7672 |
| TRUCK, TRACTOR, WITH WINCH, WITHOUT CRANE M983 | 2320-01-097-0247 |
| TRUCK, TRACTOR, WITH WINCH, WITH CRANE M983 | 2320-01-099-6421 |
| TRUCK, WRECKER-RECOVERY M984 | 2320-01-097-0248 |
| TRUCK, WRECKER-RECOVERY M984E1 | 2320-01-195-7641 |
| TRUCK, CARGO, WITH WINCH M985 | 2320-01-097-0261 |
| TRUCK, CARGO, WITHOUT WINCH M985 | 2320-01-100-7673 |
| TRUCK, CARGO, WITH WINCH M985E1 | 2320-01-194-7032 |
| TRUCK, CARGO, WITHOUT WINCH M985E1 | 2320-01-194-7031 |

Approved for public release; distribution is unlimited.

HEADQUARTERS, DEPARTMENT OF THE ARMY

TABLE OF CONTENTS
PAGE i

INTRODUCTION
PAGE 1-1

EQUIPMENT DESCRIPTION
AND DATA
PAGE 1-10

VEHICLE MAINTENANCE
PAGE 2-1

PREVENTIVE MAINTENANCE
CHECKS AND SERVICES
PAGE 2-3

TROUBLESHOOTING
PAGE 2-39

MAINTENANCE PROCEDURES
PAGE 2-284

ENGINE MAINTENANCE
PAGE 3-1

FUEL SYSTEM
MAINTENANCE
PAGE 4-1

EXHAUST SYSTEM
MAINTENANCE
PAGE 5-1

COOLING SYSTEM
MAINTENANCE
PAGE 6-1

ELECTRICAL SYSTEM
MAINTENANCE
PAGE 7-1

ALPHABETICAL
INDEX
PAGE INDEX 1

07 APRIL 1987

W A R N I N G**CARBON MONOXIDE (EXHAUST GAS) CAN CAUSE DEATH.**

Carbon monoxide is without color or smell, but can cause death. Breathing air with carbon monoxide produces symptoms of headache, dizziness, loss of muscular control, a sleepy feeling, and coma. Brain damage or death can result from heavy exposure. Carbon monoxide occurs in the exhaust fumes of fuel-burning heaters and internal combustion engines. Carbon monoxide can become dangerously concentrated under conditions of no ventilation. Precautions must be followed to ensure crew safety when the personnel heater or engine of any vehicle is operated for any purpose.

1. DO NOT operate personnel heater or engine of vehicle in a closed place without proper ventilation.
2. DO NOT drive any vehicle with inspection plates, cover plates, or engine compartment covers removed unless necessary for maintenance purposes.
3. BE ALERT at all times during vehicle operation for exhaust odors and exposure symptoms. If either are present, IMMEDIATELY VENTILATE personnel compartments. If symptoms persist, remove affected crew to fresh air and keep warm. DO NOT PERMIT PHYSICAL EXERCISE. If necessary, give artificial respiration and get immediate medical attention. For artificial respiration, refer to FM 21-11.
4. BE AWARE that the gas particulate filter unit or the field protection mask for nuclear-biological-chemical protection WILL NOT offer safety from carbon monoxide poisoning.

THE BEST DEFENSE AGAINST CARBON MONOXIDE POISONING IS GOOD VENTILATION.

W A R N I N G

Adhesives, solvents, and sealing compounds can burn easily, can give off harmful vapors, and are harmful to skin and clothing. To avoid injury or death, keep away from open fire and use in well-ventilated area. If adhesive, solvent, or sealing compound gets on skin or clothing, wash immediately with soap and water.

W A R N I N G

Never use the parking brake for normal braking or wheels will lock up causing severe skid. Skidding vehicle could result in serious injury or death.

W A R N I N G

Fuel is very flammable and can explode easily. To avoid serious injury or death, keep fuel away from open fire and keep fire extinguisher within easy reach when working with fuel. Do not work on fuel system when engine is hot. Fuel can be ignited by hot engine. When working with fuel, post signs that read NO SMOKING WITHIN 50 FEET of vehicle.

W A R N I N G

Remove rings, bracelets, wristwatches, neck chains, and any other jewelry before working around vehicle. Jewelry can catch on equipment and cause injury, or may short across an electrical circuit and cause severe burns or electrical shock.

WARNING

The radiator is very hot and pressurized during vehicle operation. Let radiator cool before removing cap. Failure to do so can result in serious burns.

WARNING

The exhaust pipe and muffler can become very hot during vehicle operation. Be careful not to touch these parts with bare hands, or allow body to come in contact with pipe or muffler. Exhaust system parts can become hot enough to cause serious burns.

WARNING

Do not use trailer brakes as parking brake. Trailer brakes may not hold a loaded vehicle and trailer on a grade. A runaway vehicle may cause severe personal injury or death.

WARNING

Always use seatbelts when operating vehicle. Failure to use seatbelt can result in serious injury in case of accident.

WARNING

Avoid quick, jerking, winch operation. Keep other personnel well away from vehicles involved in winching operations. A snapped cable or shifting load can cause serious injury or death.

WARNING

Always wear heavy gloves when handling winch cables. Never let cable run through hands; frayed cables can cut. Never operate winch with less than five wraps of cable on winch drum.

WARNING

If operating crane under powerlines, do not allow vehicle to contact high-voltage connections. Death on contact can result. If possible, keep one hand away from equipment to reduce the hazard of current flowing through vital organs of the body.

WARNING

When working inside the vehicle with power off, be sure to ground every capacitor likely to hold a dangerous voltage potential.

WARNING

Never work on electronic equipment unless there is another person nearby who is familiar with the operation and hazards of the equipment.

WARNING

Be careful when working on or with electrical equipment. Do not be misled by the term "low voltage". Voltages as low as 50 volts may cause death. For artificial respiration, refer to FM 21-11.

WARNING

Be careful not to short out battery terminals. Do not smoke or use open flame near batteries. Batteries may explode from a spark, Battery acid is harmful to skin and eyes.

WARNING

Brake shoes may be coated with dust. Breathing this dust may be harmful to your health. Do not use compressed air to clean brake shoes. Wear a filter mask approved for use against brake dust. Failure to comply may result in injury or death to personnel.

WARNING

Starting fluid is toxic and flammable. Do not store in cab and do not breathe fumes. Do not puncture or burn containers. Dispose of container following manufacturer's recommendations on the container.

WARNING

Compressed air used for cleaning purposes will not exceed 30 psi (207 kPa). Use only with effective chip guarding and personal protective equipment, goggles, shield, and gloves.

WARNING

After Nuclear, Biological, or Chemical (NBC) exposure of vehicle, all air filters shall be handled with extreme caution. Unprotected personnel can experience injury or death if residual toxic agents or radioactive material are present. If vehicle is exposed to chemical or biological agents, servicing personnel shall wear protective mask, hood, protective overgarments, and chemical protective gloves and boots in accordance with TM 10-277. All contaminated air filters shall be placed in double-lined plastic bags and moved swiftly to a segregation area away from the worksite. The same procedure applies for radioactive dust contamination. The Company NBC team should measure the radiation prior to filter removal to determine the extent of safety procedures required per the NBC Annex to the unit Standard Operating Procedures (SOP). The segregation area in which the contaminated air filters are temporarily stored shall be marked with appropriate NBC placards. Final disposal of contaminated air filters shall be in accordance with local SOP. Decontamination operation shall be in accordance with TM 3-220 and local SOP.

WARNING

If NBC exposure is suspected, all air filter media should be handled by personnel wearing protective equipment. Consult your unit NBC Officer or NBC NCO for appropriate handling or disposal instructions.

WARNING

Drycleaning solvent (P-D-680) is TOXIC and flammable. Wear protective goggles, face shield, and gloves; use only in well-ventilated area; avoid contact with skin, eyes, and clothes, and do not breathe vapors. Keep away from heat or flame. Never smoke when using solvent; the flashpoint for type I drycleaning solvent is 100°F (38°C) and for type II is 140°F (60°C). Failure to do so may result in injury or death to personnel.

If personnel become dizzy while using cleaning solvent, immediately get fresh air and medical help. If solvent contacts skin or clothes, flush with cold water. If solvent contacts eyes, immediately flush eyes with water and get immediate medical attention.

WARNING

Do not check tire pressure before referring to TM 9-2320-279-10 for proper tire pressure checking procedure. Personal injury or death could result.

WARNING

When inflating tires mounted on the vehicle, all personnel must remain out of trajectory of the side ring and lockring as shown by the areas indicated. Failure to follow proper procedures may result in serious injury or death to personnel.

WARNING

During pressure tests, ensure air pressure is drained to 0 psi (0 kPa) before taking off any components. If pressure is not released, plates or line could blow off and harm personnel. Do not drain air from tank with any part of body in air spray path. Skin embolisms and/or debris in eyes can occur from released pressure.

WARNING

Always completely deflate tire by removing valve core from valve stem before attempting demounting operation. After air has finished exhausting from valve stem, carefully run a piece of wire through valve stem to ensure it is not plugged and tire is completely deflated. Failure to comply may result in injury to personnel.

WARNING

High air pressure may be released from valve stem when valve core is removed. Stay clear of valve stem after core is removed. Ensure all personnel wear suitable eye protection. Failure to comply may result in injury to personnel.

WARNING

Stand clear of trajectory area during deflation or personal injury or death may result.

WARNING

Lockring is under tension. If lockring breaks loose it could cause injury to personnel. Keep hands and fingers away from lockring when removing.

WARNING

When lockring snaps into position it could pinch hands and fingers. Do not allow hands or fingers to get between lockring and lockring groove when installing lockring or injury to personnel may result.

WARNING

Raised notch on lockring must face away from wheel or lockring will not seat properly in lockring groove causing lockring to unseat possibly causing injury to personnel.

WARNING

Cracked, broken, bent or otherwise damaged rim components shall not be reworked, welded, brazed, or otherwise heated or damage or personal injury or death may result.

WARNING

No heat shall be applied to a multi-piece wheel or wheel component or damage or injury or death may result.

WARNING

Lockring must be fully seated in lockring groove around the entire circumference or lockring could unseat during tire inflation causing serious injury to personnel.

WARNING

If gap is greater than 3/8 in. (9.5 mm), reposition or replace lockring, or injury or death to personnel may result. Destroy defective lockring so it cannot be reused.

WARNING

Failure to place wheel/tire assembly in safety cage prior to initial inflation could result in serious injury or death to personnel.

WARNING

When a wheel/tire is in a restraining device, do not rest or lean any part of body or equipment on or against the restraining device, or injury or death could result.

WARNING

While changing tires or while performing tire maintenance, stay out of the trajectory as shown by the area indicated. Failure to follow proper procedures may result in injury or death to personnel.

WARNING

Improperly seated lockrings and side rings may blow off at any time. Never attempt to seat a lockring or side ring during or after inflation. Failure to comply may result in serious injury or death.

WARNING

When inflating tires, always use an inflation hose with an in-line gage and a clip-on chuck. The gage and valve must be mounted a minimum of 10 feet (3.10 m) away from air chuck.

WARNING

All personnel must remain a minimum of 10 feet (3.10 m) away from tire and not in possible path of lockring or side ring. Failure to comply may result in serious injury or death.

WARNING

Do not inflate above 3 psi (21 kPa) or personal injury or death may result.

WARNING

Never inflate tires over 40 psi (276 kPa) to seat tire beads. If beads do not seat, deflate, demount, and check the tire/rim parts. Relubricate and remount tire. Serious injury or death could result if these procedures are not followed.

WARNING

If gap in lockring is greater than 3/8 in. (9.5 mm), deflate wheel/tire assembly by removing valve core, then replace lockring, or serious injury or death to personnel may result. Destroy defective lockring so it cannot be reused.

INSERT LATEST UPDATED PAGES/WORK PACKAGES, DESTROY SUPERSEDED DATE

LIST OF EFFECTIVE PAGES/WORK PACKAGES

NOTE: The portion of text affected by the updates is indicated by a vertical line in the outer margins of the page. Updates to illustrations are indicated by miniature pointing hands. Updates to wiring diagrams are indicated by shaded areas.

Dates of issue for original and updated pages/work packages are:

| | | | |
|----------------|-----------------|--------------|------------------|
| Original ... 0 | April 1987 | Change ... 3 | 15 December 1998 |
| Change ... 1 | 31 October 1988 | Change ... 4 | 15 December 2000 |
| Change ... 2 | 20 April 1993 | Change ... 5 | 15 February 2002 |

**TOTAL NUMBER OF PAGES IN THIS PUBLICATION IS 1018
CONSISTING OF THE FOLLOWING:**

| Page/WP No. | *Change No. | Page/WP No. | *Change No. | Page/WP No. | *Change No. |
|-------------|-------------|-------------------|-------------|---------------|-------------|
| Cover | 3 | 2-10 | 3 | 2-52 - 2-59 | 3 |
| Blank | 0 | 2-10.1 - 2-10.2 | 3 | 2-60 | 0 |
| a - b | 0 | 2-11 - 2-19 | 2 | 2-61 - 2-62 | 3 |
| c - e | 3 | 2-20 - 2-22 | 3 | 2-63 - 2-65 | 0 |
| f Blank | 3 | 2-23 - 2-38 | 2 | 2-66 | 3 |
| i | 5 | 2-39 | 3 | 2-66.1 | 3 |
| ii | 0 | 2-40 - 2-48 | 2 | 2-66.2 Blank | 3 |
| iii | 3 | 2-48.1 - 2-48.8 | 2 | 2-67 - 2-79 | 0 |
| iv | 2 | 2-48.10 - 2-48.16 | 2 | 2-80 | 4 |
| v - viii | 1 | 2-48.17 | 3 | 2-81 - 2-95 | 0 |
| 1-1 - 1-8 | 0 | 2-48.18 - 2-48.21 | 2 | 2-96 | 2 |
| 1-9 | 3 | 2-48.22 | 5 | 2-97 - 2-113 | 0 |
| 1-10 - 1-24 | 0 | 2-48.22.1 | 5 | 2-114 | 3 |
| 2-1 | 3 | 2-48.22.2 Blank | 5 | 2-114.1 | 3 |
| 2-2 | 0 | 2-48.23 - 2-48.28 | 2 | 2-114.2 Blank | 3 |
| 2-3 | 3 | 2-48.29 | 3 | 2-115 | 3 |
| 2-4 | 2 | 2-48.30 - 2-48.31 | 2 | 2-116 - 2-117 | 0 |
| 2-5 | 3 | 2-48.32 | 3 | 2-118 | 3 |
| 2-6 | 2 | 2-48.33 | 5 | 2-119 | 0 |
| 2-6.1 | 4 | 2-48.34 Blank | 2 | 2-120 - 2-122 | 5 |
| 2-6.2 | 3 | 2-49 | 2 | 2-122.1 | 5 |
| 2-7 | 3 | 2-50 | 0 | 2-122.2 Blank | 0 |
| 2-8 - 2-9 | 2 | 2-51 | 2 | 2-123 | 3 |

* Zero in this column indicates an original page.

INSERT LATEST UPDATED PAGES/WORK PACKAGES, DESTROY SUPERSEDED DATE

| Page/WP No. | *Change No. | Page/WP No. | *Change No. | Page/WP No. | *Change No. |
|-------------------|-------------|---------------|-------------|--------------|-------------|
| 2-124 - 2-128 | 0 | 2-334 - 2-336 | 0 | 5-4 | 0 |
| 2-129 | 5 | 2-337 | 3 | 5-5 | 0 |
| 2-130 - 2-131 | 0 | 2-338 - 2-339 | 0 | 5-6 | 3 |
| 2-132 | 5 | 2-340 - 2-346 | 3 | 5-6.1 | 3 |
| 2-133 | 0 | 3-1 - 3-3 | 0 | 5-6.2 Blank | 3 |
| 2-134 | 3 | 3-4 | 2 | 6-1 | 5 |
| 2-134.1 - 2-134.4 | 3 | 3-5 - 3-6 | 0 | 6-2 | 3 |
| 2-135 - 2-136 | 0 | 3-7 | 2 | 6-3 | 0 |
| 2-137 | 5 | 3-8 - 3-15 | 0 | 6-4 | 3 |
| 2-138 - 2-148 | 0 | 3-16 - 3-17 | 3 | 6-5 - 6-19 | 0 |
| 2-149 | 3 | 3-18 - 3-21 | 0 | 6-20 | 3 |
| 2-150 - 2-152 | 0 | 3-22 | 3 | 6-21 - 6-46 | 0 |
| 2-153 - 2-154 | 3 | 4-1 - 4-10 | 0 | 6-46.1 | 5 |
| 2-154.1 - 2-154.2 | 3 | 4-11 | 3 | 6-46.2 Blank | 5 |
| 2-155 - 2-197 | 0 | 4-12 - 4-15 | 0 | 6-47 - 6-48 | 5 |
| 2-198 | 3 | 4-16 - 4-17 | 3 | 6-49 | 3 |
| 2-199 | 0 | 4-18 - 4-21 | 0 | 6-50 | 0 |
| 2-200 | 3 | 4-22 | 3 | 6-51 | 3 |
| 2-201 - 2-209 | 0 | 4-23 | 5 | 6-52 | 0 |
| 2-210 | 5 | 4-24 - 4-26 | 3 | 7-1 - 7-2 | 5 |
| 2-211 - 2-223 | 4 | 4-27 - 4-28 | 0 | 7-3 | 0 |
| 2-224 | 5 | 4-28.1 | 4 | 7-4 | 5 |
| 2-225 - 2-228 | 0 | 4-28.2 Blank | 4 | 7-5 - 7-6 | 5 |
| 2-229 | 3 | 4-29 | 3 | 7-6.1 | 5 |
| 2-230 - 2-231 | 0 | 4-30 | 5 | 7-6.2 Blank | 5 |
| 2-232 | 3 | 4-31 - 4-33 | 0 | 7-7 - 7-8 | 0 |
| 2-232.1 | 5 | 4-34 - 4-38 | 3 | 7-9 - 7-10 | 5 |
| 2-232.2 Blank | 5 | 4-38.1 Blank | 3 | 7-10.1 | 5 |
| 2-233 | 5 | 4-38.2 | 3 | 7-10.2 Blank | 5 |
| 2-234 - 2-241 | 0 | 4-39 - 4-41 | 3 | 7-11 - 7-12 | 0 |
| 2-242 | 3 | 4-42 - 4-51 | 0 | 7-13 - 7-14 | 5 |
| 2-243 - 2-249 | 0 | 4-52 - 4-54 | 3 | 7-15 - 7-25 | 0 |
| 2-250 | 3 | 4-54.1 | 3 | 7-26 | 3 |
| 2-251 - 2-256 | 2 | 4-54.2 Blank | 3 | 7-27 - 7-31 | 0 |
| 2-269 Blank | 3 | 4-55 - 4-56 | 0 | 7-32 | 3 |
| 2-270 | 3 | 5-1 | 0 | 7-33 - 7-35 | 0 |
| 2-271 - 2-285 | 0 | 5-2 | 3 | 7-36 | 3 |
| 2-286 - 2-333 | 3 | 5-3 | 3 | 7-37 | 0 |

* Zero in this column indicates an original page.

INSERT LATEST UPDATED PAGES/WORK PACKAGES, DESTROY SUPERSEDED DATE

| Page/WP No. | *Change No. | Page/WP No. | *Change No. | Page/WP No. | *Change No. |
|--------------|-------------|-------------------|-------------|-------------------|-------------|
| 7-38 | 3 | 7-101 - 7-113 | 0 | 7-199.1 - 7-199.3 | 4 |
| 7-38.1 | 3 | 7-114 - 7-115 | 3 | 7-199.4 Blank | 4 |
| 7-38.2 Blank | 3 | 7-116 - 7-120 | 0 | 7-200 - 7-208 | 0 |
| 7-39 - 7-41 | 0 | 7-121 | 3 | 7-209 | 3 |
| 7-42 | 4 | 7-122 - 7-125 | 0 | 7-210 | 0 |
| 7-43 | 0 | 7-126 | 4 | 7-211 - 7-212 | 3 |
| 7-44 | 4 | 7-127 - 7-137 | 0 | 7-213 | 0 |
| 7-45 - 7-48 | 0 | 7-138 | 4 | 7-214 | 3 |
| 7-49 - 7-50 | 4 | 7-139 - 7-141 | 0 | 7-215 | 0 |
| 7-51 - 7-60 | 0 | 7-142 | 4 | 7-216 | 3 |
| 7-61 - 7-62 | 3 | 7-143 - 7-145 | 0 | 7-217 | 0 |
| 7-63 | 5 | 7-146 - 7-148 | 3 | 7-218 - 7-222 | 5 |
| 7-64 - 7-65 | 3 | 7-149 | 4 | 7-222.1 - 7-222.2 | 5 |
| 7-66 | 5 | 7-150 | 0 | 7-222.3 | 5 |
| 7-67 | 3 | 7-150.1 | 5 | 7-222.4 Blank | 5 |
| 7-68 | 5 | 7-150.2 Blank | 5 | 7-223 - 7-225 | 5 |
| 7-69 - 7-70 | 3 | 7-151 | 5 | 7-226 | 0 |
| 7-71 | 5 | 7-152 - 7-154 | 0 | 7-226.1 - 7-226.2 | 5 |
| 7-72 | 3 | 7-154.1 | 5 | 7-227 | 5 |
| 7-72.1 | 5 | 7-154.2 Blank | 5 | 7-228 - 7-229 | 0 |
| 7-72.2 Blank | 5 | 7-155 | 5 | 7-230 | 5 |
| 7-73 | 5 | 7-156 - 7-167 | 0 | 7-230.1 | 5 |
| 7-74 | 0 | 7-168 - 7-169 | 3 | 7-230.2 Blank | 5 |
| 7-75 | 3 | 7-170 | 5 | 7-231 | 5 |
| 7-76 - 7-79 | 0 | 7-170.1 - 7-170.2 | 5 | 7-232 - 7-241 | 0 |
| 7-80 | 5 | 7-171 - 7-187 | 0 | 7-242 | 3 |
| 7-81 - 7-82 | 0 | 7-188 - 7-192 | 3 | 7-242.1 | 3 |
| 7-83 | 4 | 7-193 - 7-194 | 4 | 7-242.2 Blank | 3 |
| 7-84 | 0 | 7-195 | 3 | 7-243 | 3 |
| 7-85 | 4 | 7-196 | 4 | 7-244 - 7-268 | 0 |
| 7-86 | 0 | 7-197 | 3 | 7-269 - 7-270 | 4 |
| 7-87 | 4 | 7-198 | 4 | 7-270.1 | 3 |
| 7-88 - 7-90 | 0 | 7-198.1 | 3 | 7-270.2 - 7-270.6 | 4 |
| 7-91 | 4 | 7-198.2 | 4 | 7-271 | 0 |
| 7-92 - 7-96 | 0 | 7-198.3 | 3 | 7-272 | 5 |
| 7-97 | 4 | 7-198.4 Blank | 3 | 7-273 | 0 |
| 7-98 | 0 | 7-198.5 - 7-198.8 | 5 | 7-274 - 7-275 | 5 |
| 7-99 - 7-100 | 4 | 7-199 | 3 | 7-276 - 7-289 | 0 |

* Zero in this column indicates an original page.

INSERT LATEST UPDATED PAGES/WORK PACKAGES, DESTROY SUPERSEDED DATE

| | | | | | |
|-------------------|---|---------------|---|---------------------|---|
| 7-290 - 7-291 | 5 | 7-322 | 0 | 7-348.2 Blank | 3 |
| 7-292 - 7-293 | 3 | 7-323 | 4 | 7-349 - 7-352 | 0 |
| 7-294 - 7-295 | 0 | 7-324 | 3 | 7-353 - 7-354 | 5 |
| 7-296 - 7-297 | 5 | 7-324.1 | 3 | 7-355 - 7-358 | 0 |
| 7-298 | 0 | 7-324.2 Blank | 3 | 7-359 | 4 |
| 7-299 | 3 | 7-325 | 3 | 7-360 | 3 |
| 7-300 | 0 | 7-326 - 7-328 | 0 | 7-361 - 7-374 | 0 |
| 7-301 - 7-302 | 5 | 7-329 | 3 | 7-375 | 4 |
| 7-303 | 0 | 7-330 - 7-332 | 4 | 7-376 - 7-380 | 0 |
| 7-304 | 3 | 7-333 - 7-334 | 3 | Index 1 | 2 |
| 7-305 | 5 | 7-334.1 | 3 | Index 2 - Index 5 | 0 |
| 7-306 - 7-309 | 0 | 7-334.2 Blank | 3 | Index 6 - Index 7 | 2 |
| 7-310 | 5 | 7-335 | 2 | Index 8 | 3 |
| 7-310.1 - 7-310.6 | 5 | 7-336 | 0 | Index 9 | 2 |
| 7-311 - 7-318 | 0 | 7-337 | 2 | Index 10 - Index 15 | 0 |
| 7-319 - 7-321 | 3 | 7-338 | 3 | Index 16 Blank | 0 |

* Zero in this column indicates an original page.

CHANGE

NO. 5

HEADQUARTERS
DEPARTMENT OF THE ARMY
WASHINGTON, D.C., 15 February 2002

TECHNICAL MANUAL

MAINTENANCE INSTRUCTIONS

ORGANIZATIONAL MAINTENANCE

M977 SERIES, 8 X 8 HEAVY EXPANDED MOBILITY
TACTICAL TRUCKS (HEMTT)

| MODEL | NSN |
|---|------------------|
| TRUCK, CARGO, WITH WINCH, M977 | 2320-01-097-0260 |
| TRUCK, CARGO, WITHOUT WINCH, M977 | 2320-01-099-6426 |
| TRUCK, TANK, FUEL, WITH WINCH, M978 | 2320-01-097-0249 |
| TRUCK, TANK, FUEL, WITHOUT WINCH, M978 | 2320-01-100-7672 |
| TRUCK, TRACTOR, WITH WINCH, WITHOUT CRANE, M983 | 2320-01-097-0247 |
| TRUCK, TRACTOR, WITH WINCH, WITH CRANE, M983 | 2320-01-099-6421 |
| TRUCK, WRECKER-RECOVERY, M984 | 2320-01-097-0248 |
| TRUCK, WRECKER-RECOVERY, M984E1 | 2320-01-195-7641 |
| TRUCK, CARGO, WITH WINCH, M985 | 2320-01-097-0261 |
| TRUCK, CARGO, WITHOUT WINCH, M985 | 2320-01-100-7673 |
| TRUCK, CARGO, WITH WINCH, M985E1 | 2320-01-194-7032 |
| TRUCK, CARGO, WITHOUT WINCH, M985E1 | 2320-01-194-7031 |

Approved for public release; distribution is unlimited.

TM 9-2320-279-20-1, April 1987, is changed as follows:

1. Remove old pages and insert new pages as indicated below.
2. New or changed material is indicated by a vertical bar in the margin of the page.
3. Minor changes to illustrations are indicated by a miniature pointing hand.
4. Illustrations that are new or that have major revisions are indicated by a vertical bar adjacent to the illustration.

Remove Pages

i and ii
2-48.21 and 2-48.22
none
2-48.33/(2-48.34 blank)
2-119 thru 2-122
2-122.1/(2-122.2 blank)
2-129 thru 2-132

Insert Pages

i and ii
2-48.21 and 2-48.22
2-48.22.1/(2-48.22.2 blank)
2-48.33/(2-48.34 blank)
2-119 thru 2-122
2-122.1/(2-122.2 blank)
2-129 thru 2-132

Remove Pages

2-137 and 2-138
2-209 and 2-210
2-223 and 2-224
none
2-233 and 2-234
4-23 and 4-24
4-29 and 4-30
6-1 and 6-2
none
6-47 and 6-48
7-1 thru 7-6
7-6.1 and 7-6.2
7-9 and 7-10
none
7-13 and 7-14
7-63 thru 7-68
7-71 and 7-72
none
7-73 and 7-74
7-79 and 7-80
none
7-151 and 7-152
none
7-155 and 7-156
7-169 and 7-170
7-170.1/(7-170.2 blank)
none
none
7-217 thru 7-222
none
7-223 thru 7-226
none
7-227 thru 7-230
none
7-231 and 7-232
7-271 thru 7-276
7-289 thru 7-292
7-295 thru 7-298
7-301 and 7-302
7-305 and 7-306
7-309 and 7-310
none
7-353 and 7-354

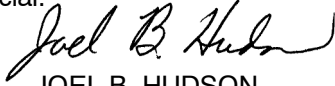
Insert Pages

2-137 and 2-138
2-209 and 2-210
2-223 and 2-224
2-232.1/(2.232.2 blank)
2-233 and 2-234
4-23 and 4-24
4-29 and 4-30
6-1 and 6-2
6-46.1/(6.46.1 blank)
6-47 and 6-48
7-1 thru 7-6
7-6-1 and 7-6.2
7-9 and 7-10
7-10.1/(7-10.2 blank)
7-13 and 7-14
7-63 thru 7-68
7-71 and 7-72
7-72.1/(7-72.2 blank)
7-73 and 7-74
7-79 and 7-80
7-150.1/(7-150.2 blank)
7-151 and 7-152
7-154.1/(7-154.2 blank)
7-155 and 7-156
7-169 and 7-170
7-170.1 and 7-170.2
7-198.5 and 7-198.6
7-198.7 and 7-198.8
7-217 thru 7-222
7-222.1 thru 7-222.3/(7-222.4 blank)
7-223 thru 7-226
7-226.1 thru 7-226.2
7-227 thru 7-230
7.230.1/(7.230.2 blank)
7-231 and 7-232
7-271 thru 7-276
7-289 thru 7-292
7-295 thru 7-298
7-301 and 7-302
7-305 and 7-306
7-309 and 7-310
7-310.1 thru 7-310.6
7-353 and 7-354

File this change sheet in front of the publication for reference purposes.

By Order of the Secretary of the Army:

Official:



JOEL B. HUDSON
*Administrative Assistant to the
Secretary of the Army*

0115506

ERIC K. SHINSEKI
*General, United States Army
Chief of Staff*

DISTRIBUTION: To be distributed in accordance with the Initial Distribution Number (IDN) 380266, requirements for TM 9-2320-279-20-2.

CHANGE

NO. 4

HEADQUARTERS
DEPARTMENT OF THE ARMY
WASHINGTON, D.C., 15 December 2000

TECHNICAL MANUAL

MAINTENANCE INSTRUCTIONS

ORGANIZATIONAL MAINTENANCE

M977 SERIES, 8 X 8 HEAVY EXPANDED MOBILITY
TACTICAL TRUCKS (HEMTT)

| MODEL | NSN |
|---|------------------|
| TRUCK, CARGO, WITH WINCH, M977 | 2320-01-097-0260 |
| TRUCK, CARGO, WITHOUT WINCH, M977 | 2320-01-099-6426 |
| TRUCK, TANK, FUEL, WITH WINCH, M978 | 2320-01-097-0249 |
| TRUCK, TANK, FUEL, WITHOUT WINCH, M978 | 2320-01-100-7672 |
| TRUCK, TRACTOR, WITH WINCH, WITHOUT CRANE, M983 | 2320-01-097-0247 |
| TRUCK, TRACTOR, WITH WINCH, WITH CRANE, M983 | 2320-01-099-6421 |
| TRUCK, WRECKER-RECOVERY, M984 | 2320-01-097-0248 |
| TRUCK, WRECKER-RECOVERY, M984E1 | 2320-01-195-7641 |
| TRUCK, CARGO, WITH WINCH, M985 | 2320-01-097-0261 |
| TRUCK, CARGO, WITHOUT WINCH, M985 | 2320-01-100-7673 |
| TRUCK, CARGO, WITH WINCH, M985E1 | 2320-01-194-7032 |
| TRUCK, CARGO, WITHOUT WINCH, M985E1 | 2320-01-194-7031 |

Approved for public release; distribution is unlimited.

TM 9-2320-279-20-1, December 1998, is changed as follows:

1. Remove old pages and insert new pages as indicated below.
2. New or changed material is indicated by a vertical bar in the margin of the page.
3. Minor changes to illustrations are indicated by a miniature pointing hand.
4. Illustrations that are new or that have major revisions are indicated by a vertical bar adjacent to the illustration.

Remove Pages

2-6.1 and 2-6.2
2-79 and 2-80
2-209 thru 2-224
4-28.1/(4-28.2 blank)
7-41 thru 7-44

Insert Pages

2-6.1 and 2-6.2
2-79 and 2-80
2-209 thru 2-224
4-28.1/(4-28.2 blank)
7-41 thru 7-44

Remove Pages

7-49 and 7-50
7-83 thru 7-88
7-91 and 7-92
7-97 thru 7-100
7-125 and 7-126
7-137 and 7-138
7-141 and 7-142
7-149 and 7-150
7-193 thru 7-198
7-198.1 and 7-198.2
none
7-269 thru 7-270.2
none
7-323 and 7-324
7-329 and 7-332
7-359 and 7-360
7-375 and 7-376

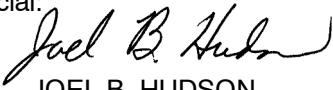
Insert Pages

7-49 and 7-50
7-83 thru 7-88
7-91 and 7-92
7-97 thru 7-100
7-125 and 7-126
7-137 and 7-138
7-141 and 7-142
7-149 and 7-150
7-193 thru 7-198
7-198.1 and 7-198.2
7-199.1 thru 7-199.3/(7-199.4 blank)
7-269 thru 7-270.2
7-270.3 thru 7-270.6
7-323 and 7-324
7-329 and 7-332
7-359 and 7-360
7-375 and 7-376

File this change sheet in front of the publication for reference purposes.

By Order of the Secretary of the Army:

Official:



JOEL B. HUDSON

*Administrative Assistant to the
Secretary of the Army*

0026310

ERIC K. SHINSEKI
*General, United States Army
Chief of Staff*

DISTRIBUTION: To be distributed in accordance with the Initial Distribution Number (IDN) 380266, requirements for TM 9-2320-279-20-2.

CHANGE

NO.3

**HEADQUARTERS
DEPARTMENT OF THE ARMY**

Washington, D. C., 15 December 1998

TECHNICAL MANUAL

MAINTENANCE INSTRUCTIONS

ORGANIZATIONAL MAINTENANCE

**M977 SERIES, 8 X 8 HEAVY EXPANDED MOBILITY
TACTICAL TRUCKS (HEMTT)**

| MODEL | NSN |
|---|------------------|
| TRUCK, CARGO, WITH WINCH, M977 | 2320-01-097-0260 |
| TRUCK, CARGO, WITHOUT WINCH, M977 | 2320-01-099-6426 |
| TRUCK, TANK, FUEL, WITH WINCH, M978 | 2320-01-097-0249 |
| TRUCK, TANK, FUEL, WITHOUT WINCH, M978 | 2320-01-100-7672 |
| TRUCK, TRACTOR, WITH WINCH, WITHOUT CRANE, M983 | 2320-01-097-0247 |
| TRUCK, TRACTOR, WITH WINCH, WITH CRANE, M983 | 2320-01-099-6421 |
| TRUCK, WRECKER-RECOVERY, M984 | 2320-01-097-0248 |
| TRUCK, WRECKER-RECOVERY, M984E1 | 2320-01-195-7641 |
| TRUCK, CARGO, WITH WINCH, M985 | 2320-01-097-0261 |
| TRUCK, CARGO, WITHOUT WINCH, M985 | 2320-01-100-7673 |
| TRUCK, CARGO, WITH WINCH, M985E1 | 2320-01-194-7032 |
| TRUCK, CARGO, WITHOUT WINCH, M985E1 | 2320-01-194-7031 |

Approved for public release; distribution is unlimited.

TM 9-2320-279-20-1, 7 April 1987, is changed as follows:

1. Remove old pages and insert new pages as indicated below.
2. New or changed material is indicated by a vertical bar in the margin of the page.
3. Minor changes to illustrations are indicated by a miniature pointing hand.
4. Illustrations that are new or that have major revisions are indicated by a vertical bar adjacent to the illustration.
5. Changes on cover are: Removed VOLUME NO. 1 and added distribution statement.

| Remove Pages | Insert Pages |
|---------------------|---------------------|
| c/(d blank) | c thru e/(f blank) |
| i thru iv | i thru iv |
| 1-9 and 1-10 | 1-9 and 1-10 |
| 2-1 thru 2-6 | 2-1 thru 2-6 |
| none | 2-6.1 and 2-6.2 |
| 2-7 thru 2-10 | 2-7 thru 2-10 |

Remove Pages

none
2-19 thru 2-22
2-39 and 2-40
2-48.7 thru 2-48.10
2-48.17 and 2-48.18
2-48.29 thru 2-48.32
2-51 thru 2-62
2-65 and 2-66
none
2-113 and 2-114
none
2-115 thru 2-122
none
2-123 and 2-124
2-133 and 2-134
none
2-149 and 2-150
2-153 and 2-154
none
2-197 thru 2-200
2-229 thru 2-232
2-241 and 2-242
2-249 and 2-250
(2-269 blank)/2-270
2-285 thru 2-334
2-337 thru 2-340
3-15 thru 3-18
3-21 and 3-22
4-11 and 4-12
4-15 thru 4-18
4-21 thru 4-26
none
4-29 and 4-30
4-33 thru 4-38
none
4-39 thru 4-42
4-51 thru 4-54
none
5-1 thru 5-6
none
6-1 thru 6-4
6-19 and 6-20
6-49 thru 6-52
7-1 and 7-2
7-5 and 7-6
7-25 and 7-26
7-31 and 7-32
7-35 thru 7-38
none
7-61 thru 7-76
7-113 and 7-116

Insert Pages

2-10.1 and 2-10.2
2-19 thru 2-22
2-39 and 2-40
2-48.7 thru 2-48.10
2-48.17 and 2-48.18
2-48.29 thru 2-48.32
2-51 thru 2-62
2-65 and 2-66
2-66.1/(2-66.2 blank)
2-113 and 2-114
2-114.1/(2-114.2 blank)
2-115 thru 2-122
2-122.1/(2-122.2 blank)
2-123 and 2-124
2-133 and 2-134
2-134.1 thru 2-134.4
2-149 and 2-150
2-153 and 2-154
2-154.1 and 2-154.2
2-197 thru 2-200
2-229 thru 2-232
2-241 and 2-242
2-249 and 2-250
(2-269 blank)/2-270
2-285 thru 2-334
2-337 thru 2-346
3-15 thru 3-18
3-21 and 3-22
4-11 and 4-12
4-15 thru 4-18
4-21 thru 4-26
4-28.1/(4-28.2 blank)
4-29 and 4-30
4-33 thru 4-38
(4-38.1 blank)/4-38.2
4-39 thru 4-42
4-51 thru 4-54
4-54.1/(4-54.2 blank)
5-1 thru 5-6
5-6.1/(5-6.2 blank)
6-1 thru 6-4
6-19 and 6-20
6-49 thru 6-52
7-1 and 7-2
7-5 and 7-6
7-25 and 7-26
7-31 and 7-32
7-35 thru 7-38
7-38.1/(7-38.2 blank)
7-61 thru 7-76
7-113 and 7-116

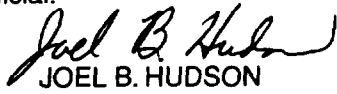
| Remove Pages | Insert Pages |
|----------------------|--------------------------------------|
| 7-121 and 7-122 | 7-121 and 7-122 |
| 7-141 and 7-142 | 7-141 and 7-142 |
| 7-145 thru 7-150 | 7-145 thru 7-150 |
| 7-167 thru 7-170 | 7-167 thru 7-170 |
| none | 7-170.1/(7-170.2 blank) |
| 7-187 thru 7-198 | 7-187 thru 7-198 |
| none | 7-198.1 thru 7-198.3/(7-198.4 blank) |
| 7-199 and 7-200 | 7-199 and 7-200 |
| 7-209 thru 7-220 | 7-209 thru 7-220 |
| 7-241 and 7-242 | 7-241 and 7-242 |
| none | 7-242.1/(7-242.2 blank) |
| 7-243 and 7-244 | 7-243 and 7-244 |
| 7-269 and 7-270 | 7-269 and 7-270 |
| none | 7-270.1 and 7-270.2 |
| 7-291 thru 7-294 | 7-291 thru 7-294 |
| 7-299 and 7-300 | 7-299 and 7-300 |
| 7-303 and 7-304 | 7-303 and 7-304 |
| 7-319 thru 7-324 | 7-319 thru 7-324 |
| none | 7-324.1/(7-324.2 blank) |
| 7-325 and 7-326 | 7-325 and 7-326 |
| 7-329 thru 7-334 | 7-329 thru 7-334 |
| none | 7-334.1/(7-334.2 blank) |
| 7-337 and 7-338 | 7-337 and 7-338 |
| 7-343 and 7-344 | 7-343 and 7-344 |
| 7-347 and 7-348 | 7-347 and 7-348 |
| none | 7-348.1/(7-348.2 blank) |
| 7-359 and 7-360 | 7-359 and 7-360 |
| Index 7 and Index 8 | Index 7 and Index 8 |
| DA 2028 sample F & B | DA 2028 sample F & B |
| DA 2028 F & B | DA 2028 F & B |
| DA 2028 F & B | DA 2028 F & B |
| DA 2028 F & B | DA 2028 F & B |
| Cover | Cover |

File this change sheet in front of the publication for reference purposes.

By Order of the Secretary of the Army:

DENNIS J. REIMER
General, United States Army
Chief of Staff

Official:



Handwritten signature of Joel B. Hudson in black ink.

JOEL B. HUDSON

*Administrative Assistant to the
Secretary of the Army*

05635

DISTRIBUTION: To be distributed in accordance with the Initial Distribution Number (IDN) 380266, requirements for TM 9-2320-279-20-1.

CHANGE
NO. 2

HEADQUARTERS
DEPARTMENT OF THE ARMY
Washington D.C., 20 April 1993

TECHNICAL MANUAL
MAINTENANCE INSTRUCTIONS
ORGANIZATIONAL MAINTENANCE

M977 SERIES, 8X8 HEAVY EXPANDED MOBILITY
TACTICAL TRUCKS (HEMTT)

| MODEL | NSN |
|---|------------------|
| TRUCK, CARGO, WITH WINCH, M977 | 2320-01-097-0260 |
| TRUCK, CARGO, WITHOUT WINCH, M977 | 2320-01-099-6426 |
| TRUCK, TANK, FUEL, WITH WINCH, M978 | 2320-01-097-0249 |
| TRUCK, TANK, FUEL, WITHOUT WINCH, M978 | 2320-01-100-7672 |
| TRUCK, TRACTOR, WITH WINCH, WITHOUT CRANE, M983 | 2320-01-097-0247 |
| TRUCK, TRACTOR, WITH WINCH, WITH CRANE, M983 | 2320-01-099-6421 |
| TRUCK, WRECKER-RECOVERY, M984 | 2320-01-097-0248 |
| TRUCK, WRECKER-RECOVERY, M984E1 | 2320-01-195-7641 |
| TRUCK, CARGO, WITH WINCH, M985 | 2320-01-097-0261 |
| TRUCK, CARGO, WITHOUT WINCH, M985 | 2320-01-100-7673 |
| TRUCK, CARGO, M WITH WINCH, M985E1 | 2320-01-094-7032 |
| TRUCK, CARGO, WITHOUT WINCH, M985E1 | 2320-01-094-7031 |

TM 9-2320-279-20-1 dated 7 April 1987, is changed as follows:

1. Remove old pages and insert new pages as indicated below.
2. New or changed information is indicated by a vertical bar in the margin of the page.
3. Minor changes to illustrations are indicated by a miniature pointing hand.
4. Illustrations that are new or that have major revisions are indicated by a vertical bar adjacent to the illustration identification number.

| <i>Remove Pages</i> | <i>Insert Pages</i> | <i>Remove Pages</i> | <i>Insert Pages</i> |
|---------------------|----------------------|-----------------------|-----------------------|
| iii thru vi | iii thru vi | 3-3 and 3-4 | 3-3 and 3-4 |
| 2-3 thru 2-52 | 2-3 thru 2-52 | 3-7 and 3-8 | 3-7 and 3-8 |
| 2-55 thru 2-58 | 2-55 thru 2-58 | 4-23 and 4-24 | 4-23 and 4-24 |
| 2-65 and 2-66 | 2-65 and 2-66 | 4-29 and 4-30 | 4-29 and 4-30 |
| 2-95 and 2-96 | 2-95 and 2-96 | 7-335 thru 7-344 | 7-335 Sthru 7-344 |
| 2-251 thru 2-268 | 2-251 thru 2-256 | Index 1 and Index 2 | Index 1 and Index 2 |
| 2-269 and 2-270 | (2-269 blank)/ 2-270 | Index 5 thru Index 10 | Index 5 thru Index 10 |

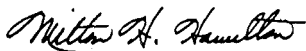
3. File this change sheet in front of the publication for reference purposes.

APPROVED FOR PUBLIC RELEASE; DISTRIBUTION IS UNLIMITED

By Order of the Secretary of the Army:

GORDON R. SULLIVAN
General, United States Army
Chief of Staff

Official:


MILTON H. HAMILTON
Administrative Assistant to the
Secretary of the Army

04043

Distribution:

To be distributed in accordance with DA Form 12-38-E, Block 0266, requirements for TM 9-2320-279-20-1.

CHANGE

NO. 1

HEADQUARTERS
DEPARTMENT OF THE ARMY
Washington, D.C., 31 October 1988

MAINTENANCE INSTRUCTIONS

ORGANIZATIONAL

M977 SERIES, 8 X 8 HEAVY EXPANDED MOBILITY
TACTICAL TRUCKS (HEMTT)

| MODEL | NSN |
|---|------------------|
| TRUCK, CARGO, WITH WINCH M977 | 2320-01-097-0260 |
| TRUCK, CARGO, WITHOUT WINCH M977 | 2320-01-099-6426 |
| TRUCK, TANK, FUEL, WITH WINCH M978 | 2320-01-097-0249 |
| TRUCK, TANK, FUEL, WITHOUT WINCH M978 | 2320-01-100-7672 |
| TRUCK, TRACTOR, WITH WINCH, WITHOUT CRANE M983 | 2320-01-097-0247 |
| TRUCK, TRACTOR, WITH WINCH, WITH CRANE M983 | 2320-01-099-6421 |
| TRUCK, WRECKER-RECOVERY M984 | 2320-01-097-0248 |
| TRUCK, WRECKER-RECOVERY M984E1 | 2320-01-195-7641 |
| TRUCK, CARGO, WITH WINCH M985 | 2320-01-097-0261 |
| TRUCK, CARGO, WITHOUT WINCH M985 | 2320-01-100-7673 |
| TRUCK, CARGO WITH WINCH M985E1 | 2320-01-194-7032 |
| TRUCK, CARGO, WITHOUT WINCH M985E1 | 2320-01-194-7031 |

TM 9-2320-279-20-1, 7 April 1987, is changed as follows:

1. Remove old pages and insert new pages as indicated below.
2. New or changed material is indicated by a vertical bar in the margin of the page.

Remove Pages

v through viii

Insert Pages

v through viii

File this change sheet in the front of the publication for reference purposes.

By Order of the Secretary of the Army:

Official:

CARL E. VUONO
General, United States Army
Chief of Staff

WILLIAM J. MEEHAN II
Brigadier General, United States Army
The Adjutant General

Distribution:

To be distributed in accordance with DA Form 12-38, Unit
Maintenance requirements for Truck, Cargo, 10-Ton, 8X8, Heavy
Expanded Mobility Tactical Truck, HEMTT, M997, M978, M983,
M984, M985

MAINTENANCE INSTRUCTIONS
ORGANIZATIONAL

**M977 SERIES, 8 X 8 HEAVY EXPANDED MOBILITY
TACTICAL TRUCKS (HEMTT)**

| MODEL | NSN |
|---|------------------|
| TRUCK, CARGO, WITH WINCH, M977 | 2320-01-097-0260 |
| TRUCK, CARGO, WITHOUT WINCH, M977 | 2320-01-099-6426 |
| TRUCK, TANK, FUEL, WITH WINCH, M978 | 2320-01-097-0249 |
| TRUCK, TANK, FUEL, WITHOUT WINCH, M978 | 2320-01-100-7672 |
| TRUCK, TRACTOR, WITH WINCH, WITHOUT CRANE, M983 | 2320-01-097-0247 |
| TRUCK, TRACTOR, WITH WINCH, WITH CRANE, M983 | 2320-01-099-6421 |
| TRUCK, WRECKER-RECOVERY, M984 | 2320-01-097-0248 |
| TRUCK, WRECKER-RECOVERY, M984E1 | 2320-01-195-7641 |
| TRUCK, CARGO, WITH WINCH, M985 | 2320-01-097-0261 |
| TRUCK, CARGO, WITHOUT WINCH, M985 | 2320-01-100-7673 |
| TRUCK, CARGO, WITH WINCH, M985E1 | 2320-01-194-7032 |
| TRUCK, CARGO, WITHOUT WINCH, M985E1 | 2320-01-194-7031 |

Approved for public release; distribution is unlimited.

REPORTING ERRORS AND RECOMMENDING IMPROVEMENTS

You can help improve this publication. If you find any mistakes or if you know of a way to improve the procedures, please let us know. Submit your DA Form 2028 (Recommended Changes to Equipment Technical Publications), through the Internet, on the Army Electronic Product Support (AEPS) Web site. The Internet address is <http://aeps.ria.army.mil>. If you need a password, scroll down and click on "ACCESS REQUEST FORM." The DA Form 2028 is located in the ONLINE FORMS PROCESSING section of the AEPS. Fill out the form and click on SUBMIT. Using this form on the AEPS will enable us to respond quicker to your comments and better manage the DA Form 2028 program. You may also mail, fax, or e-mail your letter or DA Form 2028 direct to: AMSTA-LC-CI/TECH PUBS, TACOM-RI, 1 Rock Island Arsenal, Rock Island, IL 61299-7630. The e-mail address is TACOM-TECH-PUBS@ria.army.mil. The fax number is DSN 793-0726 or Commercial (309) 782-0726.

M983 with crane and M985E1 without winch are no longer in the fleet. Ignore all references to these vehicles. The M984E1 and M984A1 are the same vehicle. All references to M984E1 shall be interpreted as the M984A1 model.

TABLE OF CONTENTS

| | Page |
|--|-------------|
| HOW TO USE THIS MANUAL | vii |
| CHAPTER 1 INTRODUCTION | 1-1 |
| Section I General Information | 1-1 |
| Section II Equipment Description and Data | 1-10 |
| Section III Principles of Operation | 1-12 |

TABLE OF CONTENTS (CONT)

| | Page |
|---|---------|
| CHAPTER 2: VEHICLE MAINTENANCE | 2-1 |
| Section I Introduction | 2-1 |
| Section II Repair Parts, Special Tools, and Test, Measurement, and Diagnostic Equipment | 2-1 |
| Section III Service Upon Receipt. | 2-2 |
| Section IV Preventive Maintenance Checks and Services. | 2-3 |
| Section V Troubleshooting | 2-50 |
| Section VI Maintenance Procedures | 2-334 |
| Section VII Preparation for Storage or Shipment | 2-340 |
| CHAPTER 3: ENGINE MAINTENANCE | 3-1 |
| Section I Introduction | 3-1 |
| Section II Engine Assembly. | 3-1 |
| Section III Engine Lubrication Systems | 3-8 |
| CHAPTER 4: FUEL SYSTEM MAINTENANCE | 4-1 |
| Section I Introduction | 4-1 |
| Section II Air Cleaner | 4-2 |
| Section III Fuel Tank and Lines. | 4-16 |
| Section IV Engine Stop Solenoid | 4-31 |
| Section V Fuel Filters | 4-32 |
| Section VI Engine Starting Aid | 4-43 |
| Section-VII Throttle Controls | 4-47 |
| CHAPTER 5: EXHAUST SYSTEM MAINTENANCE | 5-1 |
| Section I Introduction | 5-1 |
| Section II Muffler | 5-1 |
| CHAPTER 6: COOLING SYSTEM MAINTENANCE | 6-1 |
| Section I Introduction | 6-1 |
| Section II Radiator | 6-2 |
| Section III Thermostats. | 6-23 |
| Section IV Fan | 6-36 |
| CHAPTER 7: ELECTRICAL SYSTEM MAINTENANCE | 7-1 |
| Section I Introduction | 7-3 |
| Section II Alternator and Voltage Regulator | 7-3 |
| Section III Starter | 7-11 |
| Section IV Engine Safety Controls. | 7-15 |
| Section V Instrument and Control Panels | 7-76 |
| Section VI Junction Boxes | 7-142 |
| Section VII Miscellaneous Switches | 7-166 |
| Section VIII Lights | 7-185 |
| Section IX Sending Units and Warning Systems. | 7-261 |
| Section X Batteries and Battery Box | 7-298 |
| Section XI Chassis Wiring Components. | 7-320.3 |
| CHAPTER 8 TRANSMISSION MAINTENANCE | 8-1 |
| Section I Introduction | 8-1 |
| Section II Shift Control | 8-1 |
| Section III Transmission. | 8-10 |
| Section IV Filter | 8-16 |

TABLE OF CONTENTS (CONT)

| | Page |
|--------------|---|
| CHAPTER 9 | TRANSFER CASE AND PROPELLER SHAFT MAINTENANCE 9-1 |
| Section I | Introduction 9-1 |
| Section II | Transfer Case 9-1 |
| Section III | Propeller Shafts and Universal Joints 9-24 |
| CHAPTER 10 | AXLE MAINTENANCE 10-1 |
| Section I | Introduction 10-1 |
| Section II | Front Axles 10-1 |
| Section III | Rear Axle Shafts 10-7 |
| CHAPTER 11 | BRAKE AND AIR SYSTEM MAINTENANCE 11-1 |
| Section I | Introduction 11-2 |
| Section II | Brakes 11-2 |
| Section III | Brake System Valves 11-31 |
| Section IV | Air Dryer 11-74 |
| Section V | Air Reservoirs and Manifolds 11-90 |
| Section VI | Transfer Case Lockup Valve 11-111 |
| Section VII | Air-hoses.. 11-146 |
| Section VIII | Air Governor and Compressor 11-161 |
| Section IX | Trailer Connection System 11-172 |
| CHAPTER 12 | WHEEL MAINTENANCE 12-1 |
| Section I | Introduction 12-1 |
| Section II | Hub and Drum 12-1 |
| Section III | Wheel/Tire Assembly 12-24 |
| CHAPTER 13 | STEERING SYSTEM 13-1 |
| Section I | Introduction 13-1 |
| Section II | Steering Wheel and Linkage 13-1 |
| Section III | Hydraulic Reservoir and Hoses 13-18 |
| CHAPTER 14 | FRAME, AND TIRE CARRIER MAINTENANCE..... 14-1 |
| Section I | Introduction 14-1 |
| Section II | Decking, Skid Plate, and Frame Attachments..... 14-2 |
| Section III | Catwalks and Generator Mount 14-20 |
| Section IV | Towing and Retriever System 14-26 |
| Section V | Tire Carrier and Fifth Wheel 14-33 |
| CHAPTER 15 | SUSPENSION MAINTENANCE 15-1 |
| Section I | Introduction 15-1 |
| Section II | Shock Absorbers and Torque Rods 15-1 |
| CHAPTER 16 | CAB AND BODY MAINTENANCE 16-1 |
| Section I | Introduction 16-2 |
| Section II | Cab, Doors, and Engine Covers 16-2 |
| Section III | Splash Guards, Fenders, and Mudflaps 16-46 |
| Section IV | Seats..... 16-131 |
| Section V | Stowage Boxes 16-114 |
| Section VI | Cable Reels and Hose Reels 16-186 |
| Section VII | Cargo Body 16-166 |
| Section VIII | Tanker Body 16-189 |
| Section IX | Wrecker Body 16-210 |

TABLE OF CONTENTS (CONT)

CHAPTER 17 WINCHES, CRANES, AND POWER TAKEOFF MAINTENANCE 17-1

 Section I Introduction 17-1

 Section II Cable Tensioners and Guides 17-2

 Section III Winches 17-48

 Section IV Cranes 17-69

 Section V Winch and Crane Controls 17-104

 Section VI Power Takeoff 17-132

 Section VII Outriggers and Outrigger Controls 17-152

CHAPTER 18 BODY ACCESSORY ITEMS 18-1

 Section I Introduction 18-1

 Section II Windshield Wiper/Washer Maintenance 18-2

 Section III Safety Accessories 18-13

 Section IV Fuel hoses, Nozzles, and Control Valves 18-30

 Section V Heater and Defroster 18-38

CHAPTER 19 HYDRAULIC SYSTEM MAINTENANCE 19-1

 Section I Introduction 19-1

 Section II Hydraulic Hand Pump 19-2

 Section III Hydraulic Control Valves 19-5

 Section IV Hydraulic Lines and Fluid Filter 19-49

CHAPTER 20 ARCTIC KIT MAINTENANCE 20-1

 Section I Introduction 20-1

 Section II Arctic Heater Kit 20-1

CHAPTER 21 ARMAMENT EQUIPMENT MAINTENANCE 21-1

 Section I Introduction 21-1

 Section II Armament 21-1

CHAPTER 22 NON-ELECTRICAL GAGE MAINTENANCE 22-1

 Section I Introduction 22-1

 Section II Gages 22-1

CHAPTER 23 FILTER-SEPARATOR MAINTENANCE 23-1

 Section I Introduction 23-1

 Section II Filter-Separator 23-1

CHAPTER 24 RADIO KIT MAINTENANCE 24-1

 Section I Introduction 24-1

 Section II Radio Kit 24-1

CHAPTER 25 M978 TANKER MAINTENANCE 25-1

 Section I Introduction 25-1

 Section II Service and Inspection 25-2

 Section III Tubing, Pumps, and Air Eliminator 25-14

 Section IV Piping and Valves 25-50

TABLE OF CONTENTS (CONT)

| | Page |
|---|---------|
| CHAPTER 26 CHEMICAL, BIOLOGICAL, AND RADIOLOGICAL (CBR) EQUIPMENT MAINTENANCE | 26-1 |
| Section I Introduction | 26-1 |
| Section II Chemical, Biological, and Radiological Equipment | 26-1 |
| CHAPTER 27 M983 AUXILIARY ELECTRICAL POWER SYSTEM MAINTENANCE | 27-1 |
| Section I Introduction | 27-1 |
| Section II Auxiliary Electrical Power System | 27-1 |
| APPENDIXES | |
| A REFERENCES | A-1 |
| B MAINTENANCE ALLOCATION CHART | B-1 |
| C EXPENDABLE SUPPLIES AND MATERIALS | C-1 |
| D PREPARATION FOR TOWING | D-1 |
| E TORQUE LIMITS | E-1 |
| F ILLUSTRATED LIST OF MANUFACTURED ITEMS | F-1 |
| INDEX | Index 1 |

LIST OF ILLUSTRATIONS

| Figure | Title | Page |
|--------|---|-------|
| 1-1 | M977 Cargo Vehicle | 1-2 |
| 1-2 | M978 Fuel Tanker Vehicle | 1-3 |
| 1-3 | M983 Tractor Vehicle with Material Handling Crane | 1-4 |
| 1-4 | M983 Tractor Vehicle Without Crane.. . . . | 1-5 |
| 1-5 | M984 Wrecker-Recovery Vehicle | 1-6 |
| 1-6 | M984E1 Wrecker-Recovery Vehicle | 1-7 |
| 1-7 | M985 Cargo Vehicle | 1-8 |
| 1-8 | M985E1 Cargo Vehicle | 1-9 |
| 1-9 | Power Train | 1-13 |
| 1-10 | Air Intake System | 1-14 |
| 1-11 | Fuel System | 1-14 |
| 1-12 | Cooling System | 1-15 |
| 1-13 | Electrical System | 1-15 |
| 1-14 | Air System | 1-17 |
| 1-15 | Hydraulic System | 1-18 |
| 1-16 | Steering System | 1-19 |
| 1-17 | Self-Recovery Winch | 1-20 |
| 1-18 | Cranes | 1-21 |
| 1-19 | Recovery Winch (M984 and M984E1 Only) | 1-22 |
| 1-20 | Wheels and Tires | 1-23 |
| 1-21 | Tanker Equipment | 1-24 |
| 2-1 | STE/ICE Connector | 2-2 |
| 2-2 | Circuit Breakers (Center Console) | 2-40 |
| 2-3 | M985E1 HIGH IDLE Wiring Diagram | 2-63 |
| 2-4 | M984 HIGH IDLE Wiring Diagram | 2-64 |
| 2-5 | M984 HIGH IDLE Control Assembly | 2-70 |
| 2-6 | M985E1 HIGH IDLE Control Assembly | 2-71 |
| 2-7 | Winch Controller Wiring Diagram | 2-101 |
| 2-8 | Winch Controller Wiring Diagram | 2-131 |
| 2-9 | Remote Controller Electrical Schematic (M977, M985) | 2-163 |
| 2-10 | Remote Controller Wiring Diagram (M977, M985) | 2-164 |
| 2-11 | Tanker Component Identification | 2-166 |
| 2-12 | Tanker Fuel System Functional Diagram | 2-167 |
| 2-13 | Taker Operation Functional Diagram. | 2-168 |
| 2-14 | Tanker Fuel System Schematic. | 2-180 |

LIST OF ILLUSTRATIONS (CONT)

| Figure | Title | Page |
|-----------|---|-------------|
| 2 - 1 5 | Wiring Diagram-Engine Heater Model CP3050A (24 Volt) | 2 - 2 1 4 |
| 2 - 1 6 | Wiring Diagram-Personnel Heater Model AP3050-24FB | 2 - 2 2 3 |
| 2 - 1 7 | STE/ICE Vehicle Test | 2 - 2 3 3 |
| 2 - 1 8 | Relationship of GO, NO-GO Tests | 2 - 2 3 5 |
| 2 - 1 9 | STE/ICE System | 2 - 2 3 6 |
| 2 - 2 0 | VTM Controls and Readout Display | 2 - 2 3 7 |
| 2 - 2 1 | Cable Assemblies | 2 - 2 3 9 |
| 2 - 2 2 | Connector Key Location | 2 - 2 3 9 |
| 2 - 2 3 | Transducer Kit | 2 - 2 4 0 |
| 7 - 1 | ENGINE HIGH IDLE Box Assembly Wiring Diagram (M977, M985) | 7 - 3 0 |
| 7 - 2 | Main Overload Switch Wiring. | 7 - 1 7 2 |
| 7 - 3 | Reduced Overload and Mast Overload Switch Wiring | 7 - 1 7 3 |
| 7 - 4 | Electrical Conduit Tubing. | 7 - 1 8 0 |
| 9 - 1 | Capscrew Torque Limits | 9 - 2 5 |
| 1 1 - 1 | Engine Airhoses | 1 1 - 1 4 1 |
| 1 1 - 2 | Wiper and Air Horn Hoses. | 1 1 - 1 4 3 |
| 1 1 - 3 | Chassis Airhoses | 1 1 - 1 4 5 |
| 1 1 - 4 | Brake Airhoses | 1 1 - 1 4 9 |
| 1 1 - 5 | Cab Airhoses | 1 1 - 1 5 1 |
| 1 1 - 6 | Air Manifold No. 4 | 1 1 - 1 5 2 |
| 1 9 - 1 | Typical Hydraulic Line Brackets | 1 9 - 4 7 |
| 1 9 - 2 | Hydraulic Lines-M977, M985 Without Winch | 1 9 - 4 9 |
| 1 9 - 3 | Hydraulic Lines-M977, M985 With Winch | 1 9 - 5 1 |
| 1 9 - 4 | Hydraulic Lines-M983 With Crane | 1 9 - 5 3 |
| 1 9 - 5 | Hydraulic Lines-M983 Without Crane | 1 9 - 5 5 |
| 1 9 - 6 | Hydraulic Lines-M978 With Winch | 1 9 - 5 7 |
| 1 9 - 7 | Hydraulic Lines-M978 Without Winch | 1 9 - 5 9 |
| 1 9 - 8 | Hydraulic Lines-M985E1 Without Winch | 1 9 - 6 1 |
| 1 9 - 9 | Hydraulic Lines-M985E1 With Winch | 1 9 - 6 3 |
| 1 9 - 1 0 | Hydraulic Lines-M984 | 1 9 - 6 5 |
| 1 9 - 1 1 | Hydraulic Lines-M984E1 | 1 9 - 6 7 |
| 2 5 - 1 | Tanker External Components | 2 5 - 2 |
| 2 5 - 2 | Tanker Filter and Manual Dispensing Components | 2 5 - 3 |
| 2 5 - 3 | Tanker Dispensing Valves. | 2 5 - 3 |
| 2 5 - 4 | Tanker Loading and Servicing Components | 2 5 - 4 |
| 2 5 - 5 | Tanker Module Tubing | 2 5 - 1 7 |
| 2 5 - 6 | Tanker Piping | 2 5 - 5 6 |
| 2 5 - 7 | Tanker Piping Brackets | 25-61 |
| F - 1 | Cable Assembly | F-10 |
| F - 2 | Chains | F-12 |
| F - 3 | Wire Assembly | F-13 |
| F - 4 | Hose Assembly | F-16 |
| F - 5 | Channel | F-21 |
| F - 6 | Looms and Sleeving | F-22 |
| F - 7 | Strap Liner | F-23 |
| F - 8 | Seals and Weatherstrip | F-23 |
| F - 9 | Tubing | F-24 |
| F - 1 0 | Gasket Strip | F-26 |
| F - 1 1 | Cord Assembly | F-26 |
| F - 1 2 | Quickedge Molding | F-27 |
| F - 1 3 | Fasteners | F-27 |
| F - 1 4 | Roof Tape | F-28 |
| F - 1 5 | 1350860W Wire Harness Assembly | F-29 |
| F - 1 6 | 1354460W Wire Harness Assembly | F-29 |
| F - 1 7 | 1353360W Wire Assembly. | F-30 |
| F - 1 8 | 1358560W Wire Assembly. | F-30 |
| F O - 1 | Electrical Schematic | FP-1 |
| F O - 2 | Air Schematic | FP-5 |
| F O - 3 | Hydraulic Schematic | FP-7 |

LIST OF TABLES

| Number | Title | Page |
|--------|---|--------|
| 1-1 | Nomenclature Cross-Reference | 1-9 |
| 1-2 | Principal Differences Between Models | 1-11 |
| 1-3 | Significant Hazards and Safety Recommendations | 1-12 |
| 2-1 | M977 through M985E1 Organizational Preventive Maintenance Checks and Services. | 2-5 |
| 2-2 | M977 and M985 Organizational Preventive Maintenance Checks and Services | 2-26 |
| 2-3 | M978 Organizational Preventive Maintenance Checks and Services | 2-28 |
| 2-4 | M983 Organizational Preventive Maintenance Checks and Services | 2-29 |
| 2-5 | M984 Organizational Preventive Maintenance Checks and Services | 2-31 |
| 2-5.1 | M984E1 Organizational Preventive Maintenance Checks and Services | 2-32.1 |
| 2-6 | Auxiliary Equipment Organizational Preventive Maintenance Checks and Services | 2-33 |
| 2-7 | System Symptom Index | 2-40 |
| 2-8 | Troubleshooting Subject Index | 2-44 |
| 2-9 | Troubleshooting | 2-48 |
| 2-10 | Engine GO Chain Index. Combined Mode | 2-232 |
| 2-11 | Engine NO-GO Chain Index. Combined Mode | 2-232 |
| 2-12 | Status Readout | 2-241 |
| 2-13 | Prompting Messages | 2-242 |
| 2-14 | Error Readouts | 2-244 |
| 2-15 | Transducer ID Numbers | 2-245 |
| 7-1 | Tanker Conduit Tubing | 7-179 |
| 11-1 | Engine Hose Index | 11-140 |
| 11-2 | Wiper and Air Horn Hoses. | 11-142 |
| 11-3 | Chassis Airhoses | 11-145 |
| 11-4 | Brake Airhoses | 11-149 |
| 11-5 | Cab Airhoses | 11-151 |
| 19-1 | Hydraulic Line Index for M977, M985 Without Winch | 19-48 |
| 19-2 | Hydraulic Line Index for M977, M985 With Winch | 19-50 |
| 19-3 | Hydraulic Line Index for M983 With Crane | 19-52 |
| 19-4 | Hydraulic Line Index for M983 Without Crane | 19-54 |
| 19-5 | Hydraulic Line Index for M978 With Winch | 19-56 |
| 19-6 | Hydraulic Line Index for M978 Without Winch | 19-58 |
| 19-7 | Hydraulic Line Index for M985E1 Without Winch | 19-60 |
| 19-8 | Hydraulic Line Index for M985E1 With Winch | 19-62 |
| 19-9 | Hydraulic Line Index for M984 | 19-64 |
| 19-10 | Hydraulic Line Index for M984E1 | 19-66 |
| 25-1 | Tanker Module Tubing | 25-16 |
| 25-2 | Tanker Piping | 25-54 |
| F-1 | Cable and Cable Assemblies. | F-11 |
| F-2 | Chains | F-12 |
| F-3 | Wire and Wire Assemblies. | F-13 |
| F-4 | Hose and Hose Assemblies. | F-16 |
| F-5 | Channel | F-21 |
| F-6 | Looms and Sleeving | F-22 |
| F-7 | Strap Liner | F-23 |
| F-8 | Seals and Weatherstrip | F-23 |
| F-9 | Tubing | F-24 |
| F-10 | Gasket Strip | F-26 |
| F-11 | Cord and Cord Assemblies | F-26 |
| F-12 | Quickedge Molding | F-27 |
| F-13 | Fasteners | F-27 |
| F-14 | Roof Tape | F-28 |

HOW TO USE THIS MANUAL

This manual is designed to help maintain the M977 series vehicles. In addition to this manual TM 9-2320-354-24&P provides additional unique maintenance instructions for the M984 with HIAB 8109

crane and TM 9-2320-355-24&P provides additional unique maintenance instructions for the M985E1 with HIAB 8108 crane. Listed below are some of the special features which have been put in to help locate and use needed information.

- The front cover index provides a quick reference to chapters and sections that will be used often.
 - The appendixes are located at the end of the manual. They contain a reference guide to other manuals, guidelines to reading the Maintenance Allocation Chart (MAC), a list of expendable supplies and materials, towing procedures, and torque values.
 - Subject headings and certain other essential information are printed in bold type throughout the manual to make them more visible.
- Ž The maintenance tasks describe what must be done to the vehicle before starting the task, and what must be done to return the vehicle to operating condition after the task is finished.

The manual is divided into chapters containing organizational maintenance procedures. These procedures describe a number of things such as:

- What will be needed to do the job.
- If any assistance will be needed.
- How long the job will take.
- Important safety precautions.

In addition to the text, there will be an exploded-view illustration of most steps. This illustration is keyed to the text and shows you how to take the part off and put it on. Cleaning and inspection procedures are also included when required. The following problem will describe some of the features of this manual.

PROBLEM

The vehicle operator brings vehicle into the shop with a problem. Whenever the vehicle is started, the green needle on the air pressure gage stays below 60 psi (414 kPa) for a long time, but the red needle reaches 120 psi (827 kPa) in about two minutes.

1. How do you start?

Look at the cover of the manual.

On the cover is a listing of different sections in the manual. It will be necessary to troubleshoot the problem to find the cause, so the Troubleshooting section will be needed. Open the manual to the page stated on the cover, or to find the Troubleshooting section fast, bend the pages slightly and line up the troubleshooting block on the cover with the black tab on the pages. The manual will be opened to Section V of Chapter 2, Troubleshooting.

2. What kind of problem is it?

Find it *in* the symptom index.

There are two symptom indexes in the Troubleshooting section. One is arranged alphabetically by *system symptom* and the other is arranged alphabetically by *subject/symptom*. The symptom causing the problem might be in the System Symptom Index under Air System, Dual Air Brake System, or Electrical System. In the Subject/Symptom Index, it might be under Air, Brakes, or Pressure. When the symptom to the problem is found, go to the troubleshooting procedure page listed for that symptom.

3. How can the cause of the problem be determined?

Go to page 2-93.

Troubleshooting for NOISY COMPRESSOR OPERATION is on that page. The troubleshooting procedures have columns with the headings: MALFUNCTION, TEST OR INSPECTION, and CORRECTIVE ACTION. Starting at step 1, read the procedure. Each step describes what to do and what to look for. Follow the steps, in order, to troubleshoot the symptom until the problem is found. When the problem is found, the CORRECTIVE ACTION column will describe how to fix it.

4. Let's assume it was determined that the air compressor is bad. The replacement is in paragraph 11-38.

The procedure contains all the information needed to replace the air compressor. First check the introductory material. It tells what will be needed before starting the job. Following the introductory material is an exploded-view illustration and step-by-step instructions which show how to remove and install the air compressor.

FOLLOW THESE GUIDELINES WHEN USING THIS MANUAL:

- Become familiar with the entire maintenance procedure before beginning a maintenance task.
- Read all WARNINGS and CAUTIONS before performing any procedures.

CHAPTER 1

INTRODUCTION

| Contents | Para | Page |
|--|-------------|-------------|
| Scope | 1-1 | 1-1 |
| Maintenance Forms, Records, and Reports | 1-2 | 1-9 |
| Destruction of Army Materiel to Prevent Enemy Use | 1-3 | 1-9 |
| Preparation for Storage or Shipment | 1-4 | 1-9 |
| Nomenclature Cross-Reference | 1-5 | 1-9 |
| Reporting Equipment Improvement Recommendations (EIR) | 1-6 | 1-10 |
| Equipment Improvement Report and Maintenance Digest (EIR MD) and Equipment Improvement Report and Maintenance Summary (EIR MS) | 1-7 | 1-10 |
| Warranty Information | 1-8 | 1-10 |
| Metric System | 1-9 | 1-10 |
| Vehicle Description | 1-10 | 1-10 |
| Equipment Characteristics, Capabilities, and Features | 1-11 | 1-10 |
| Location and Description of Components | 1-12 | 1-10 |
| Differences Between Models | 1-13 | 1-11 |
| Safety, Care, and Handling | 1-14 | 1-12 |
| Power Train | 1-15 | 1-13 |
| Engine Systems | 1-16 | 1-14 |
| Electrical System | 1-17 | 1-15 |
| Air System | 1-18 | 1-16 |
| Hydraulic System | 1-19 | 1-18 |
| Steering System | 1-20 | 1-19 |
| Self-Recovery Winch | 1-21 | 1-20 |
| Cranes | 1-22 | 1-21 |
| Recovery Winch | 1-23 | 1-22 |
| Retrieval System (M984E1) | 1-24 | 1-22 |
| Wheels and Tires | 1-25 | 1-23 |
| Cab | 1-26 | 1-23 |
| M978 Tanker | 1-27 | 1-24 |

Section I. GENERAL INFORMATION

Vehicle Models

1-1. SCOPE. This chapter provides general information, equipment description, and principles of operation for the M977 series vehicles.

a. Type of Manual: Organizational Maintenance Instructions, TM 9-2320-279-20.

b. Model Numbers and Equipment Names. The different vehicle models are listed below:

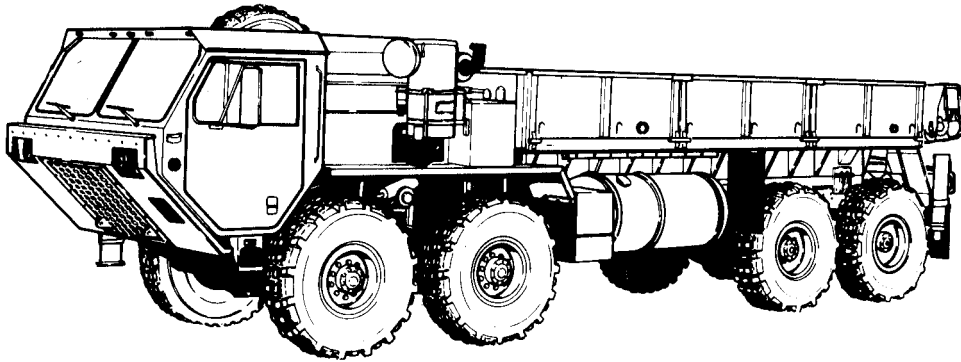
- M977: Cargo vehicle, with self-recovery winch (fig. 1-1).
Cargo vehicle, without self-recovery winch.
- M978: Fuel tanker vehicle, with self-recovery winch (fig. 1-2).
Fuel tanker vehicle, without self-recovery winch.
- M983: Tractor vehicle, with self-recovery winch and material handling crane (fig. 1-3).
Tractor vehicle, with self-recovery winch, without material handling crane (fig. 1-4).
- M984: Wrecker-recovery vehicle (fig. 1-5).
- M984E1 : Wrecker-recovery vehicle (fig. 1-6).
- M985: Cargo vehicle, with self-recovery winch (fig. 1-7).
Cargo vehicle, without self-recovery winch.
- M985E1: Cargo vehicle, with self-recovery winch (fig. 1-8).
Cargo vehicle, without self-recovery winch.

Vehicle Models (Cont)

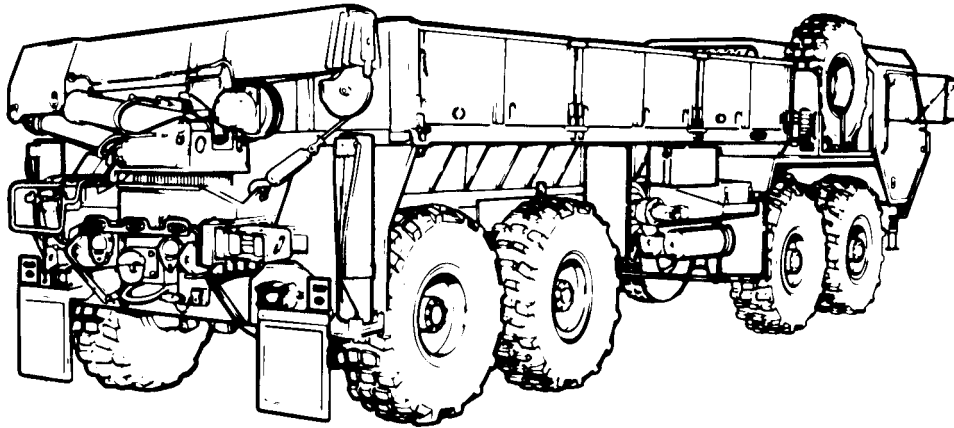
1-1. SCOPE (CONT).

c. **Purpose of Equipment.** The M977 series vehicles are a family of 8 x 8 vehicles for tactical use. The purposes of the vehicles are as follows:

- (1) The M977 cargo vehicle is used for ammunition and other resupply missions.
- (2) The M978 tanker vehicle is used to refuel wheel and track vehicles and for other fuel resupply missions.
- (3) The M983 tractor vehicle is used to transport the Pershing II and Patriot missiles.
- (4) The M984 and M984E1 wrecker-recovery vehicles are the prime recovery vehicles of the M977 series.
- (5) The M985 cargo vehicle is used to resupply the Multiple Launch Rocket System (MLRS).
- (6) The M985E1 cargo vehicle is used to resupply the Patriot Missile System.



LEFT FRONT VIEW

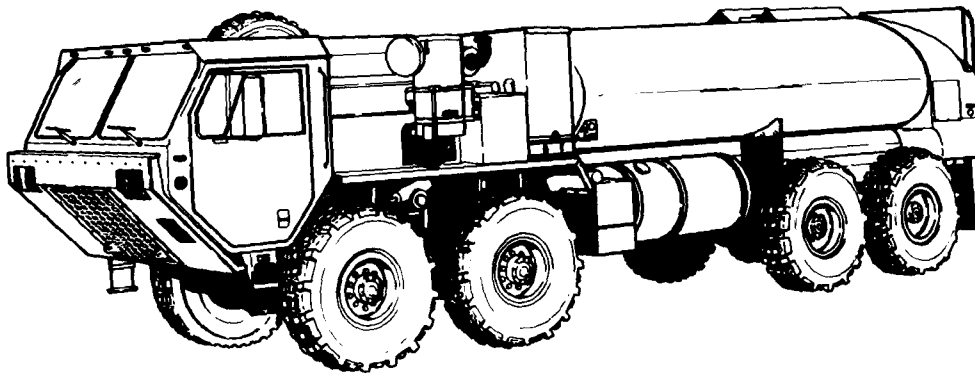


RIGHT REAR VIEW

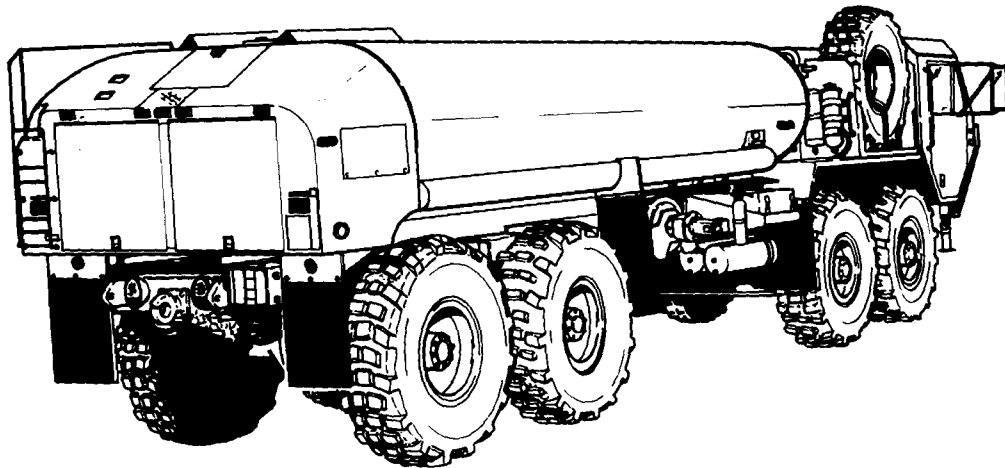
TA356920

Figure 1-1. M977 Cargo Vehicle.

Vehicle Models (Cont)



LEFT FRONT VIEW



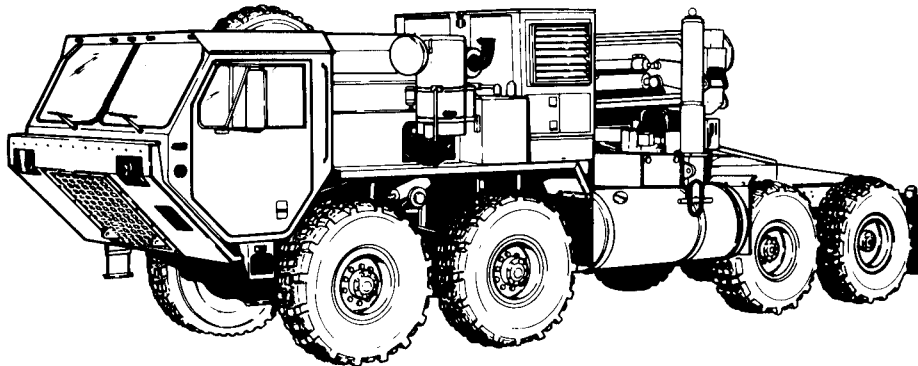
RIGHT REAR VIEW

TA356921

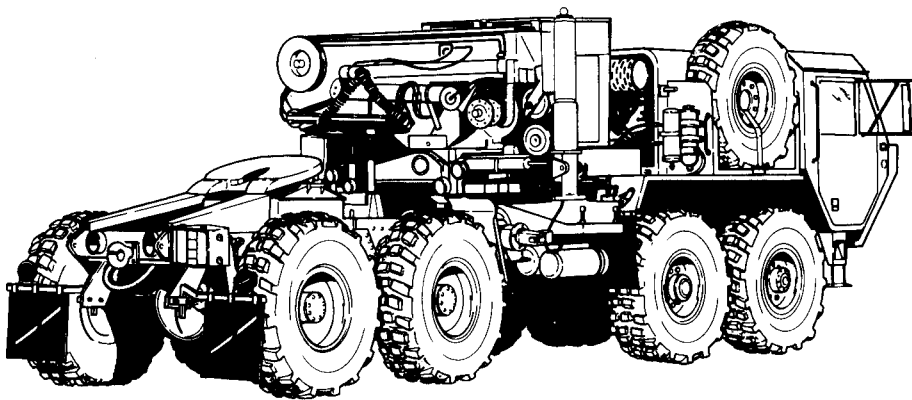
Figure 1-2. M978 Tanker Vehicle.

Vehicle Models (Cont)

1-1. SCOPE (CONT).



LEFT FRONT VIEW

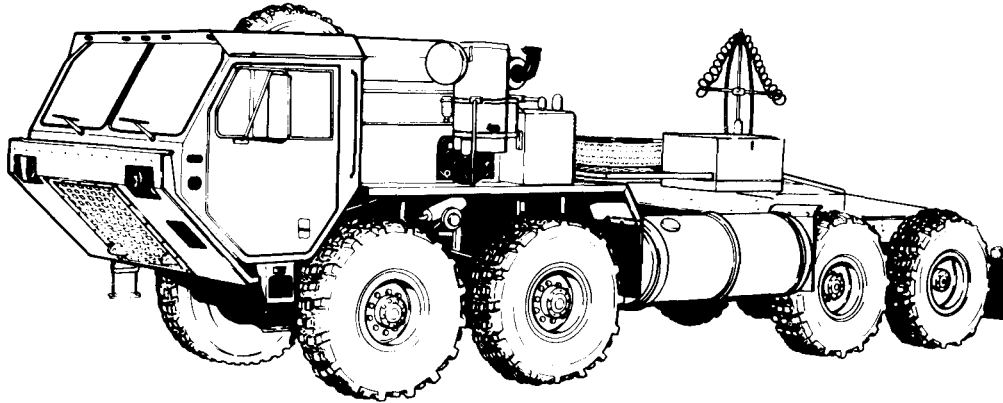


RIGHT REAR VIEW

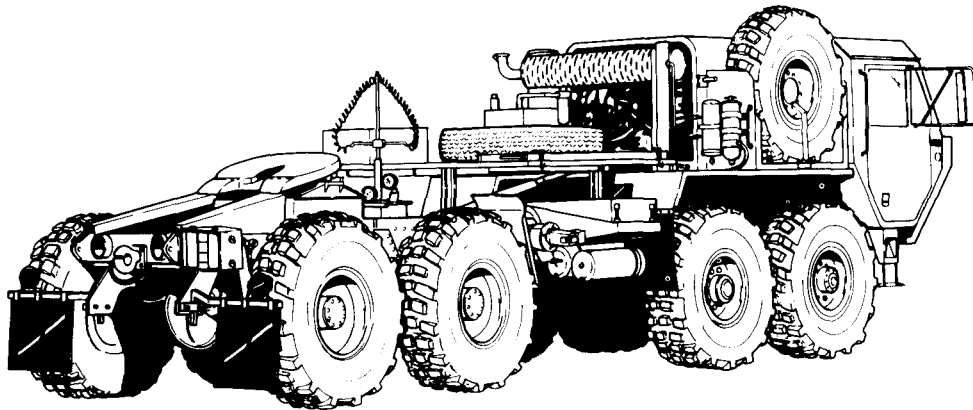
TA356922

Figure 1-3. M983 Tractor Vehicle with Crane.

Vehicle Models (Cont)



LEFT FRONT VIEW



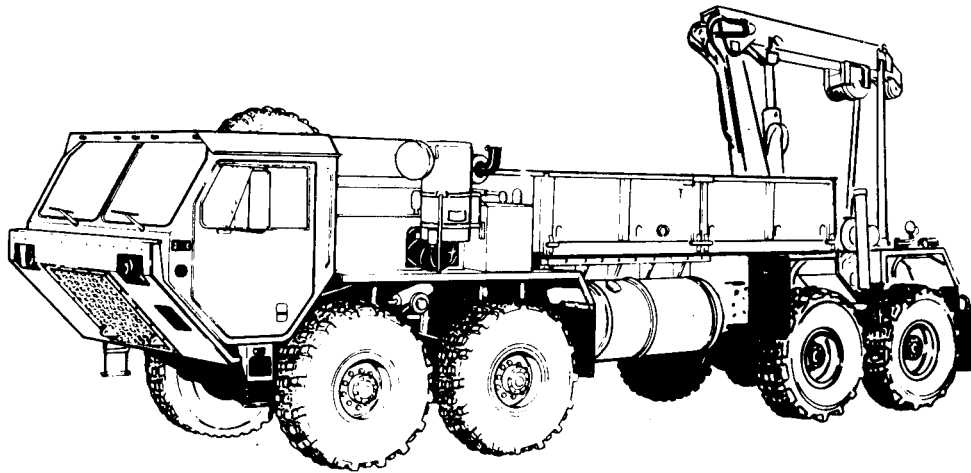
RIGHT REAR VIEW

TA356923

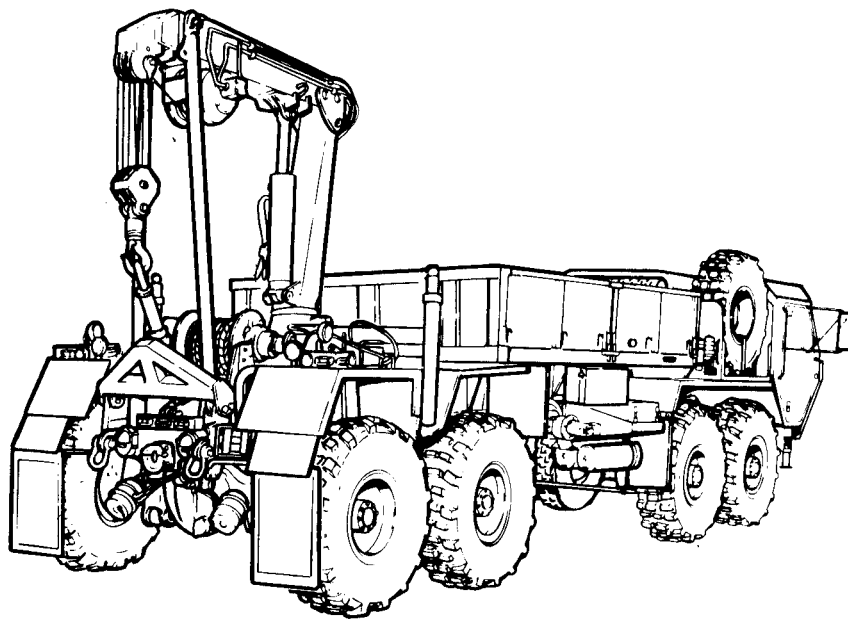
Figure 1-4. M983 Tractor Vehicle without Crane.

Vehicle Models (Cont)

1-1. SCOPE (CONT).



LEFT FRONT VIEW

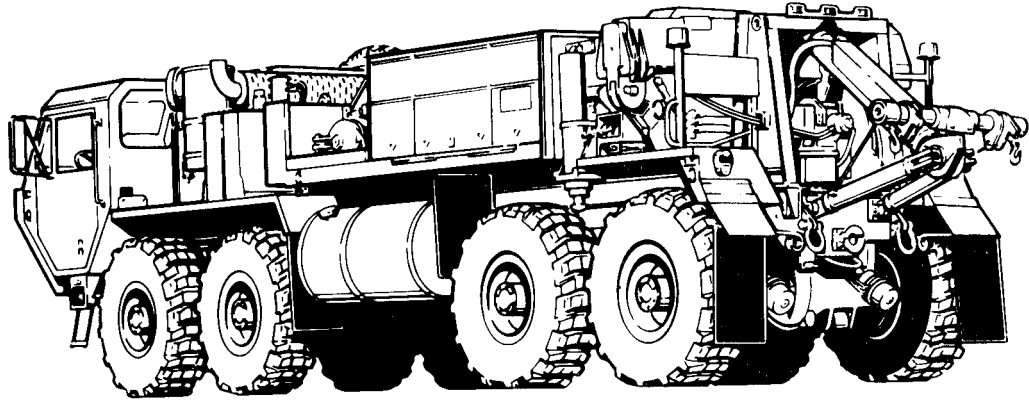


RIGHT REAR VIEW

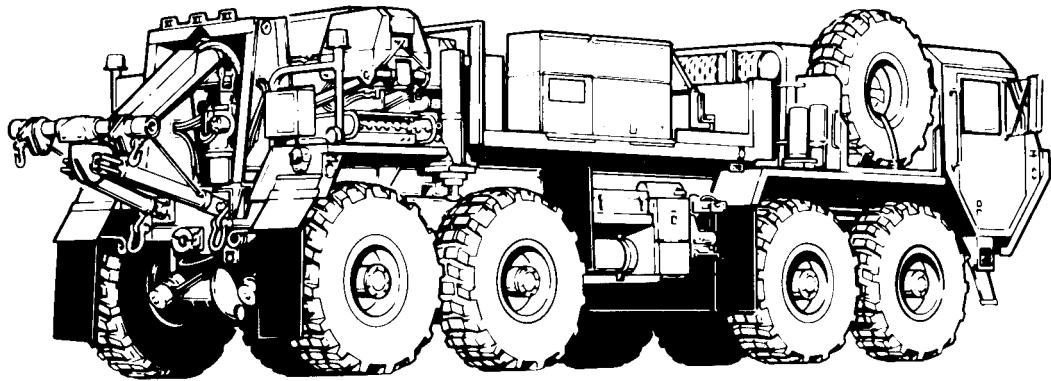
TA356924

Figure 1-5. M984 Wrecker-Recovery Vehicle.

Vehicle Models (Cont)



LEFT REAR VIEW



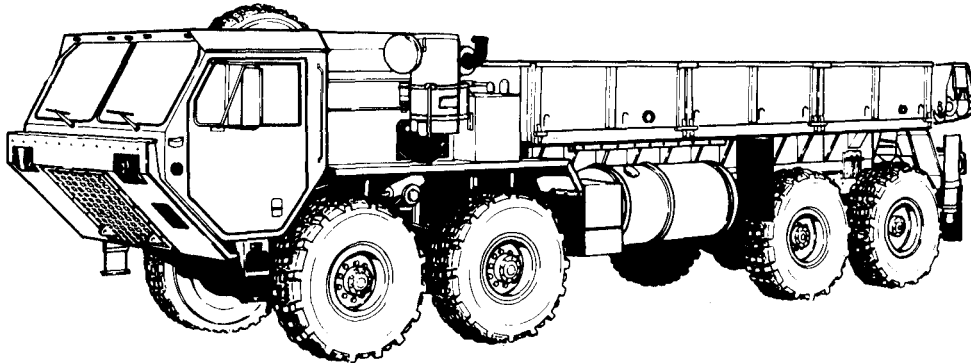
RIGHT REAR VIEW

TA356925

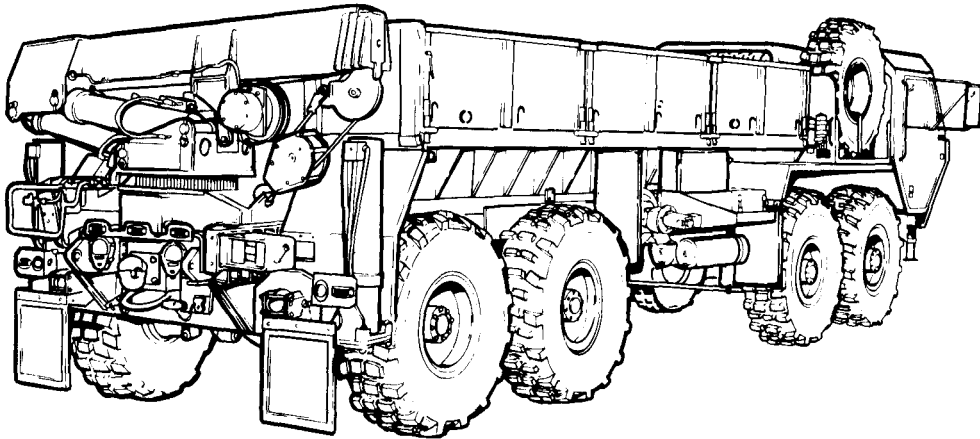
Figure 1-6. M984E1 Wrecker-Recovery Vehicle.

Vehicle Models (Cont)

1-1. SCOPE (CONT).



LEFT FRONT VIEW

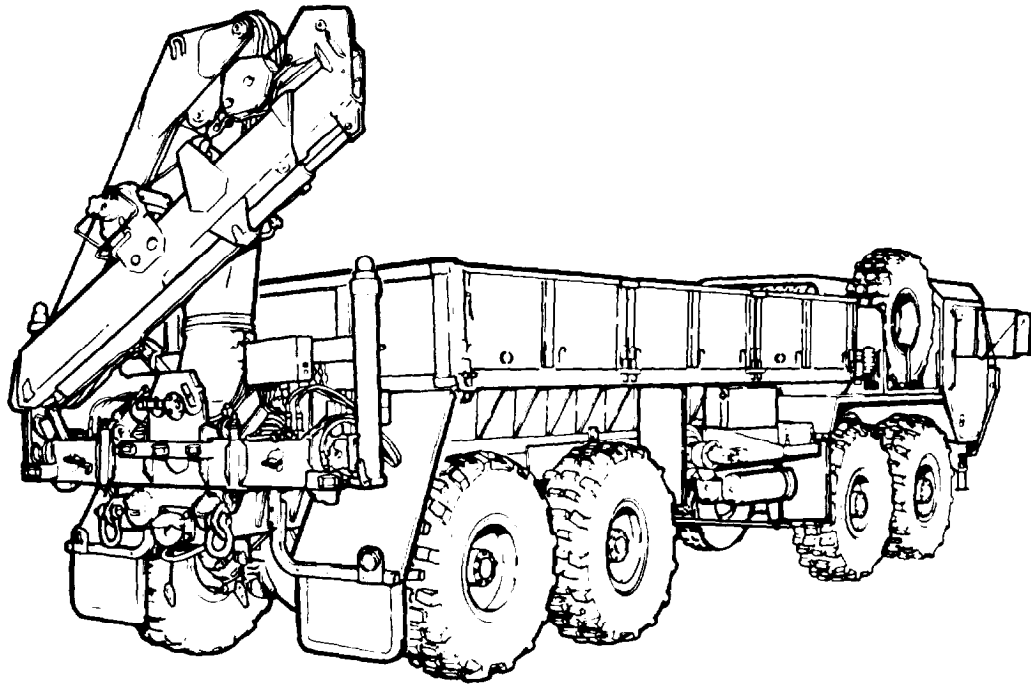


RIGHT REAR VIEW

TA356926

Figure 1-7. M985 Cargo Vehicle.

Vehicle Models (Cont)



RIGHT REAR VIEW

Figure 1-8. M985E1 Cargo Vehicle.

Equipment and Maintenance Reports

1-2. MAINTENANCE FORMS, RECORDS, AND REPORTS. Department of the Army forms and procedures used for equipment maintenance will be as specified in the latest edition of DA PAM 738-750, The Army Maintenance Management System (TAMMS).

1-3. DESTRUCTION OF ARMY MATERIEL TO PREVENT ENEMY USE. Command decision, according to the tactical situation will determine when the destruction of the M977 series vehicles will be accomplished. A destruction plan will be prepared by the using organization unless one has been prepared by a higher authority. For general destruction procedures for this equipment, refer to TM 750-244-6, Procedures for Destruction of Tank-Automotive Equipment to Prevent Enemy Use (U.S. Army Tank-automotive Command).

1-4. PREPARATION FOR STORAGE OR SHIPMENT. Instructions for preparation for storage or shipment are provided in paragraph 2-30 of this manual.

1-5. NOMENCLATURE CROSS-REFERENCE Table 1-1 lists the nomenclature cross-references used in this manual.

Table 1-1. Nomenclature Cross-Reference

| Common Name | Official Nomenclature |
|---------------------------|-------------------------------------|
| O-ring | Preformed packing |
| Snap ring | Retaining ring |
| Engine coolant | Antifreeze, ethylene glycol mixture |
| Cold Start system | Ether quick-start system |
| Jake brake, Jacobs- brake | Engine retarder |
| Cable | Wire rope |
| Glad hand | Quick disconnect coupling |

Equipment and Maintenance Reports (Cont)

1-6. REPORTING EQUIPMENT IMPROVEMENT RECOMMENDATIONS (EIR). If any vehicle needs improvement, let us know. Send us an EIR. The user is the only one who can tell us how the equipment might be improved. Let us know what isn't liked about the design. Put it on an SF 368 (Quality Deficiency Report). Mail it to us at: Commander, U.S. Army Tank-Automotive Command, ATTN: AMSTA-QRT, Warren, MI 48397-5000. We'll send a reply.

1-7. EQUIPMENT IMPROVEMENT REPORT AND MAINTENANCE DIGEST (EIR MD) AND EQUIPMENT IMPROVEMENT REPORT AND MAINTENANCE SUMMARY (EIR MS). The quarterly Equipment Improvement Report and Maintenance Digest, TB 43-0001-39 series, contains valuable field information on the equipment covered in this manual. The information in the TB 43-0001-39 series is compiled from some of the Quality Deficiency Reports that have been prepared on the vehicles covered in this manual. Many of these articles result from comments, suggestions, and improvement recommendations that were submitted to the EIR program. The TB 43-0001-39 series contains information on equipment improvements, minor alterations, proposed Modification Work Orders (MWO's), warranties (if applicable), actions taken on some of the DA Form 2028's (Recommended Changes to Publications), and advance information on proposed changes that may affect this manual. In addition, the more maintenance significant articles, including minor alterations, field-fixes, etc., that have a more permanent and continuing need in the field are republished in the Equipment Improvement Report and Maintenance Summary (EIR MS) for TACOM Equipment (TM 43-1043). Refer to both of these publications (TB 43-0001-39 series and TM 43-1043) periodically, especially the TB 43-0001-39 series, for most current and authoritative information on the equipment. The information will help to do a better job and will advise of the latest changes to this manual. Also refer to DA Pam 310-1, Consolidated Index of Army Publications and Blank Forms, and Appendix A, References, of this manual.

1-8. WARRANTY INFORMATION. The M977 series vehicles are warranted by Oshkosh Truck Corporation for 12 months or 12,000 miles (19,308 km), whichever comes first. For complete information covering this warranty, refer to Warranty Technical Bulletin, TB 9-2300-295-15/19. Warranty starts on the date found in block 23, DA Form 2408-9, in the logbook. Report all defects in material or workmanship to the supervisor, who will take appropriate action.

1-9. METRIC SYSTEM. The equipment described herein contains metric components and requires metric common and special tools; therefore, metric units in addition to English units will be used throughout this manual. An English-to-metric conversion table is included as the last page of this manual inside the back cover.

Section II. EQUIPMENT DESCRIPTION AND DATA

Features and Technical Data

1-10. VEHICLE DESCRIPTION. The M977 series vehicles are 8x8, on/off road vehicles produced in a number of different configurations. For equipment operation data, refer to operator instructions, TM 9-2320-279-10, TM 9-2320-354-10, and TM 9-2320-355-10.

1-11. EQUIPMENT CHARACTERISTICS, CAPABILITIES, AND FEATURE Refer to TM 9-2320-279-10 for equipment characteristics, capabilities, and features.

1-12. LOCATION AND DESCRIPTION OF COMPONENTS. Refer to TM 9-2320-279-10 for location and description of components.

Features and Technical Data (Cont)

1-13. DIFFERENCES BETWEEN MODELS. Refer to Table 1-2 for major differences between models.

Table 1-2. Principal Differences Between Models

| Item | Vehicle Model | | | | | | | | | | | |
|---------------------------------|---------------|--------------|-------------|--------------|-------------|--------------|------|--------|-------------|--------------|-------------|--------------|
| | M977 | | M978 | | M983 | | M984 | M984E1 | M985 | | M985E1 | |
| | W/ Winch | W/O Winch | W/ Winch | W/O Winch | W/ Crane | W/O Crane | | | W/ Winch | W/O Winch | W/ Winch | W/O Winch |
| 10-Foot (3 m) Cargo body | | | | | | | • | | | | | |
| 18-Foot (6 m) Cargo body | • | • | | | | | | | • | • | • | • |
| Wrecker Equipment Body | | | | | | | | • | | | | |
| Cargo cover kit | • | • | | | | | | | • | • | • | • |
| HD winch | | | | | | | • | • | | | | |
| Work lamps | | | | | • | • | • | • | | | | |
| Beacon Lights | | | | | | | | • | | | | |
| Model MHC977 crane | • | • | | | | | | | | | | |
| Model MHC985 crane | | | | | | | | | • | • | | |
| Model MHC984 crane | | | | | | | | • | | | | |
| Model 8108 crane | | | | | | | | | | | • | • |
| Model 8109 crane | | | | | | | • | | | | | |
| Model 8001 crane | | | | | • | | | | | | | |
| 2-inch (51 mm) fifth wheel | | | | | • | | | | | | | |
| 3.5-inch (76 mm) fifth wheel | | | | | | • | | | | | | |
| 30 KW Generator | | | | | • | | | | | | | |
| Trailer tire carrier | | | | | | • | | | | | | |
| 100 Amp alternator | | | | | • | • | | | | | | |
| 65 Amp alternator | • | • | • | • | | | • | • | • | • | • | • |

Safety and Handling

1-14. SAFETY, CARE, AND HANDLING.

a. **Significant Hazards and Safety Recommendations.** Significant hazards and safety recommendations are listed in Table 1-3.

Table 1-3. Significant Hazards and Safety Recommendations

| Hazard | Safety Recommendation or Precaution | Operating Condition¹ |
|-------------------------------------|---|--|
| Low air pressure for brakes. | Do not drive vehicle while low air pressure warning buzzer is sounding or red light is on. | Abnormal |
| Vehicle instability with crane use. | Ensure that outriggers are down on firm ground, side slope does not exceed five degrees, and crane is not overloaded. | Abnormal |
| Fire with M978 tanker. | No smoking, flames, or sparks within 50 feet (15 m). Disconnect batteries for all electrical work. | Normal |
| Fuel spills with M978 tanker. | Test tank automatic shutoff before bottom loading per procedure in instructions. Do not bypass dead-man controls. | Abnormal |
| Connecting towing devices. | Do not go between vehicles until vehicles are stopped and brakes are set. | Normal |
| Refueling vehicle. | Shut off engine and no smoking when filling tank. | Normal |

¹Category of hazards as to whether or not they may be expected under normal or abnormal operating conditions.

b. **Cranes.** Material handling cranes for models M977, M983, M984, M984E1, M985, and M985E1 all have overload shutdown and/or tilt warning (unstable) systems.

(1) On M983, M984, and M985E1 models a yellow caution light at fixed operator's station and an audible warning signal alert the operator when an unstable crane condition occurs.

(2) M983, M984, and M985E1 have an overload shutdown system which senses lift cylinder pressure to prevent overloading the crane. The system will shut down the crane to prevent hoisting, boom extension, or boom raising when an overload condition exists. Load lowering and boom retraction functions will not be affected.

(3) When M977, M985, and M984E1 cranes are overloaded, the overload system will automatically shut off power to telescope boom out, raise boom, or hoist load higher. The M977 and M984E1 overload system, will also prevent lowering the boom. An overload condition can be corrected by lowering load to ground or other supporting surface. All crane functions will be restored in approximately six seconds.

c. Crane Operating Instruction Plate Locations:

(1) The crane operating instruction plates are located on the heater compartment cover in the cab, and at each of the fixed operating stations.

(2) The outrigger leg signs are located on each of the outrigger cylinders.

(3) The load capacity signs are located at the main and auxiliary control panels and on M984E1, they are also located on the wrecker body rear stowage box doors.

Section III. PRINCIPLES OF OPERATION.

Vehicle Operation Systems

1-15. POWER TRAIN.

(fig. 1-9) Power for the vehicle is provided by a diesel engine (1) which is coupled directly to an automatic transmission (2). Power from the transmission is transferred to the transfer case (3) and on to the front and rear axles (4) through a series of propeller shafts and universal joints (5).

Vehicle Operation Systems (Cont)

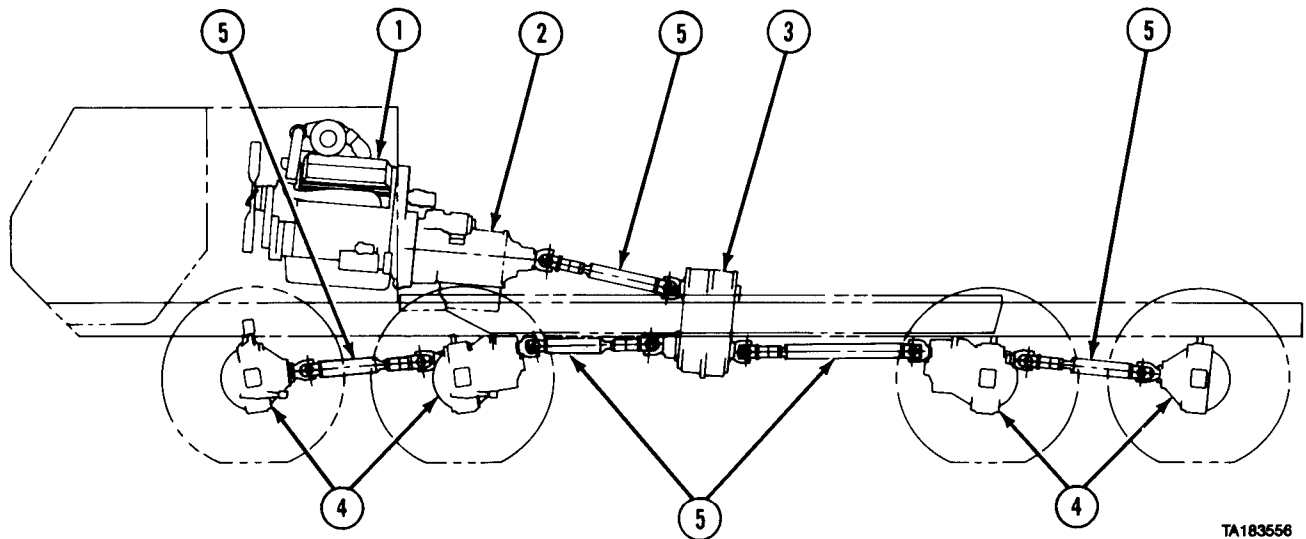


Figure 1-9. Power Train.

a. Engine. The engine (1, fig. 1-9) is a 2-cycle, turbocharged, 8-cylinder, v-block diesel unit.

b. Automatic Transmission. The automatic transmission, (2, fig. 1-9) provides four speeds forward and one reverse.

(1) Drive (D) is used for all normal driving conditions. The vehicle will start moving in 1st gear, and as the accelerator is depressed, transmission will upshift to 2nd gear, 3rd gear and 4th gear automatically. As the vehicle slows down, the transmission will downshift to the correct gear automatically. Placing the range selector lever in the 3 or 2 position will prevent the transmission from upshifting past the 3rd or 2nd gear, respectively. This is useful if road or load conditions require low gear operation. When conditions improve, the range selector lever can be returned to the normal (D) driving position. TM 9-2320-279-10 provides full operating instructions for the transmission.

(2) The transmission includes an electrically controlled power takeoff (PTO). The PTO provides power to a hydraulic pump, which powers the vehicle's hydraulic system. The hydraulic system operates the self-recovery winch, the material handling crane, the heavy duty recovery winch, and the pumping equipment, depending on how the vehicle is equipped.

c. Transfer case. The transfer case (3, fig. 1-9), connects the drive train to the No. 1 and No. 2 axles when 8-wheel drive is needed. The transfer case has two gear ratios (high and low) and neutral. Because the gears are not synchronized, the vehicle must be stopped before the transfer case can be shifted between ranges. Engagement of the transfer case in low range will automatically engage the drive train to the front axles.

d. Tandem Axles and Suspension. Front and rear tandem axles (4, fig. 1-9) are single reduction, full floating axle shaft type. The front tandem provides steering. The rear tandem is nonsteering. Both front and rear tandems are equipped with wheel differentials and interaxle differentials. The interaxle differentials have driver-controlled lockouts for positive drive to all axles in low range. The rear tandem is equipped with permanently engaged controlled traction differentials. The front and rear suspensions are tandem axle type with leaf springs and equalizer beams.

e. Propeller Shafts and Universal Joints. The propeller shafts and universal joints (5, fig. 1-9) transmit engine power to the axles.

Vehicle Operation Systems (Cont)

1-16. ENGINE SYSTEMS.

a. **Air Intake System.** (fig. 1-10) The air intake system consists of a dry type air cleaner (1), turbocharger (2), engine blower (3), and an aftercooler (4). Engine exhaust gases flow through the turbocharger (2) driving a turbine wheel. A compressor wheel on the opposite end of the turbine wheel shaft rotates and draws in fresh air through the air cleaner (1), compresses the air and delivers it to the engine blower (3). Air from the engine blower (3) flows through the aftercooler (4) which cools the air before it is delivered to the engine cylinders.

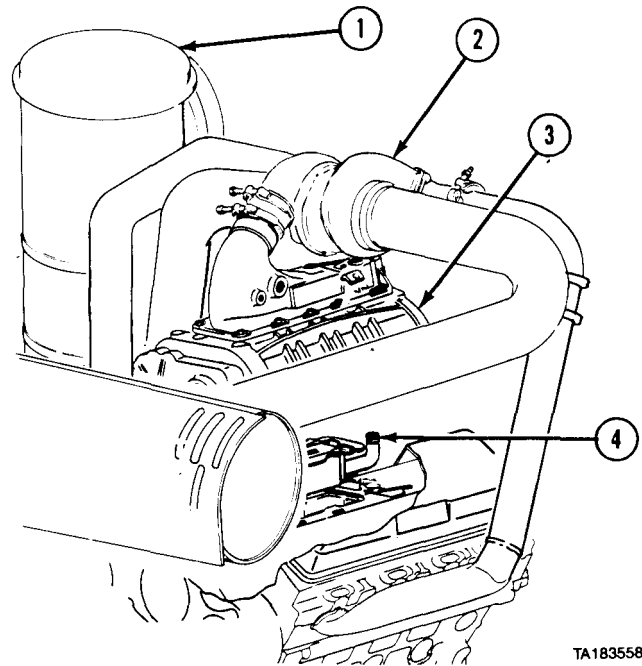


Figure 1-10. Air Intake System

b. **Fuel System.** (fig. 1-11) Fuel drawn from the fuel tank (1) passes through the supply line (2) to a fuel-water separator (3), fuel pump (4), and secondary filter (5) to the engine fuel injectors (6). Surplus fuel from injectors is returned to the fuel tank (1) through the return line (7). The fuel-water separator removes water and large solid particles from the fuel. The finer particles are removed by the secondary filter (5) before they can enter the fuel injectors.

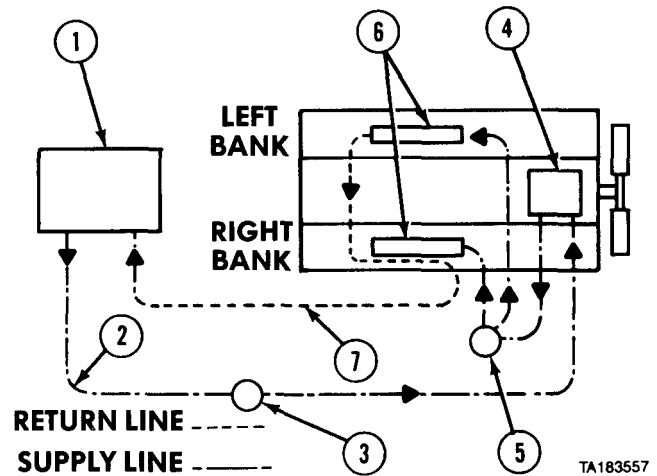


Figure 1-11. Fuel System.

Vehicle Operation Systems (Cont)

c. Cooling System. (fig. 1-12) The pressure type cooling system protects the engine by removing heat generated during the combustion process. Pressure within the cooling system is regulated by a pressure release in the radiator filler cap (1). The hot coolant flows from the engine to the top radiator tank (2) and through the radiator core (3) where a stream of air removes heat. This stream of air is drawn through the core by an air-activated fan (4). A water pump (5) draws the coolant from the bottom of the radiator and pushes it through the engine repeating the cooling process. Thermostats (6), mounted in each coolant outlet elbow, remain closed until the coolant approaches a predetermined temperature at which time they open. When the coolant temperature drops below the thermostat rating, they close. An air vent line (7) between the radiator (2) and the water pump inlet removes air trapped in the engine when the cooling system is being filled.

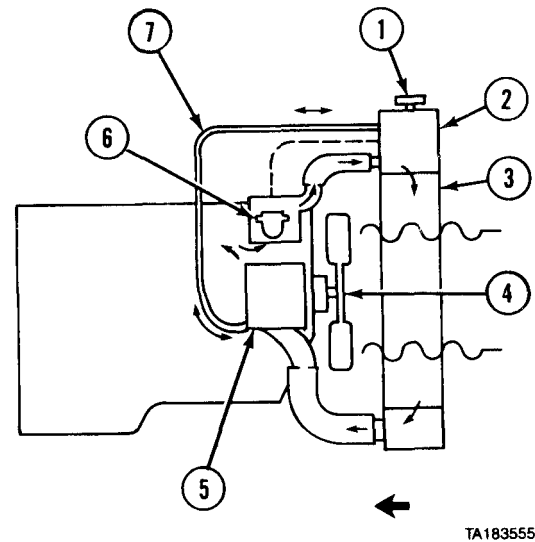


Figure 1-12. Cooling System

1-17. ELECTRICAL SYSTEM.

(fig. 1-13) The voltage and current for the electrical system are indicated by a battery gage (1) and an ammeter (2) located on the dash panel inside the drivers compartment. Circuit breakers (3) located in the cab protect the main circuits. Electrical power is provided by four 12-volt series-parallel connected batteries (4). The harnesses are interconnected by pin connectors. Connectors are provided at the rear of the vehicle to supply power for towed loads. A heavy duty starting motor (5) is mounted on the engine flywheel housing and provides the cranking power necessary for starting the engine. The voltage regulator (6) is mounted on the belt driven alternator (7) and maintains a 24-volt level for battery charging.

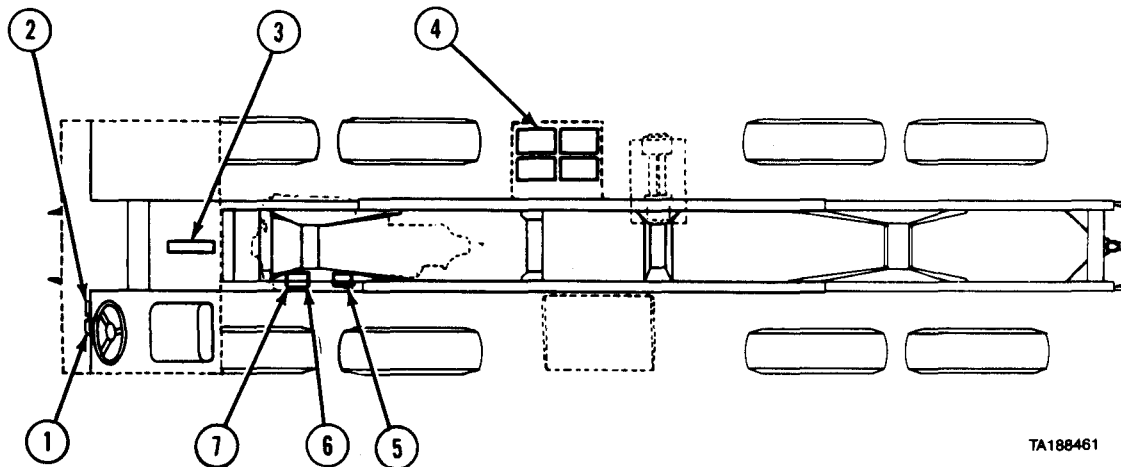


Figure 1-13. Electrical System.

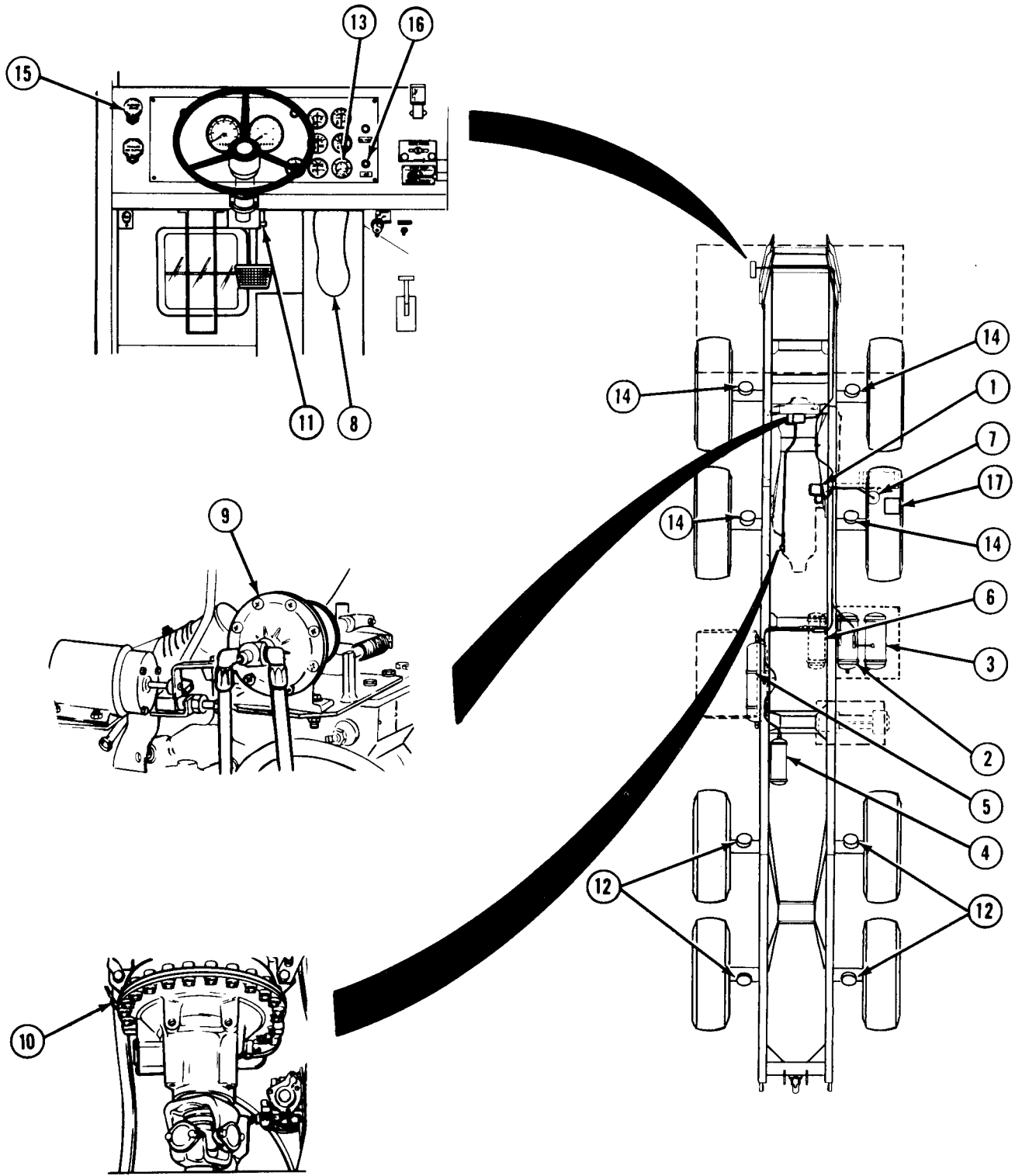
Vehicle Operation Systems (Cont)

1-18. AIR SYSTEM. (fig. 1-14) The air system consists of an engine driven air compressor (1) and four air reservoirs (2, 3, 4, and 5) (all vehicles except M983 tractor). The M983 tractor vehicle has reservoirs (2, 3, 5, and 6). The system includes the necessary valves and air lines to control the vehicle's air operated devices. Pressurized air from the air compressor (1) is passed through the air dryer (7) to the quick buildup reservoir (2). The air dryer (7) removes dirt and moisture from the pressurized air. Air from reservoir (2) goes to the throttle treadle (8). Depending on how far the throttle treadle (8) is depressed, 0 to 60 psi (0 to 414 kPa) is supplied to the engine air throttle cylinder (9) and to the transmission modulator (10). This air pressure controls vehicle speed.

Once air pressure in reservoir (2) rises above 75 psi (517 kPa), a valve opens and allows reservoirs (3, 4, or 6, and 5) to be pressurized up to 120 psi (827 kPa). Air from reservoir (4 or 6) goes to the brake treadle valve (11). This air controls the rear axle service brakes (12). Air pressure in this system is shown by the red needle on the AIR PRESS gage (13). Air from reservoir (3) goes to the brake treadle valve (11). This air controls the front axle service brakes (14). Air pressure in this system is shown by the green needle on the AIR PRESS gage (13). The PARKING BRAKE valve (15) controls air from reservoirs (3 and 5) and applies or releases the rear axle service (parking) brakes (12). Reservoirs (3, 4, or 6, and 5) are interconnected in such a way that if one reservoir fails, air would be supplied to release the rear axle service (parking) brakes (12) from whichever reservoir is functioning. If air pressure falls below 60 to 70 psi (414 to 483 kPa), a buzzer will sound, the AIR indicator (16) will light, and rear axle brakes will be applied.

On the M984E1 vehicle, the front brake actuator valve (17) is used to apply the front axle service brakes when using the heavy-duty winch.

Vehicle Operation Systems (Cont)



TA356928

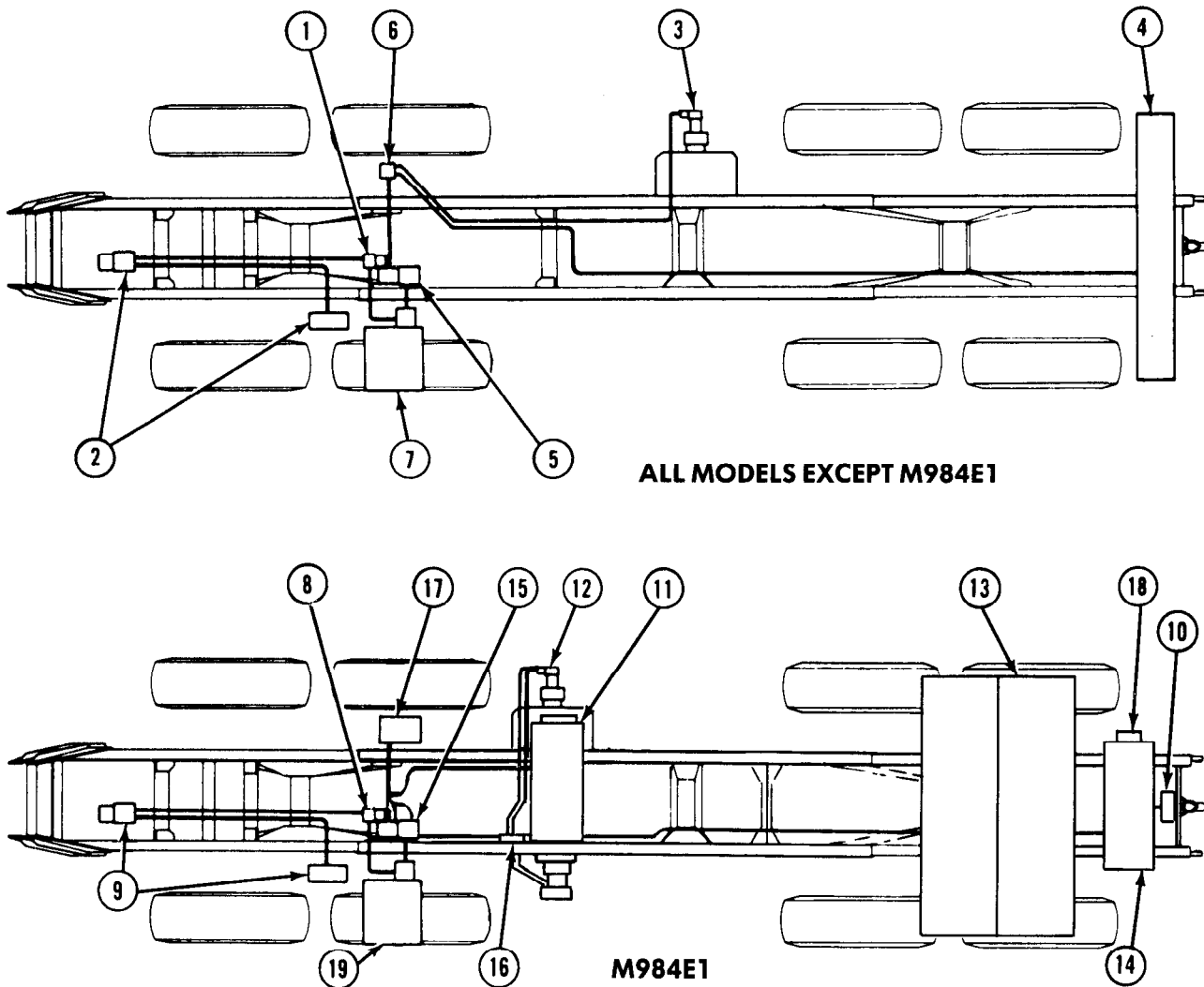
Figure 1-14. Air System.

Vehicle Operation Systems (Cont)

1-19. HYDRAULIC SYSTEM. (fig. 1-15)

a. **All Models Except M984E1.** Pump (1) mounted on the rear of engine provides the fluid power to operate the power steering (2) only. Fluid power for the self-recovery winch (3), heavy-duty winch (M984 only), crane (4) and fuel tanker dispensing components (M978 only) is provided by a hydraulic pump (5) driven by the power takeoff (PTO) mounted on the transmission. A manually operated selector valve (6) is used to activate either the self-recovery winch (3), crane (4), the heavy-duty winch (M984 only) or the fuel tanker dispensing components (M978 only). Both pumps (1) and (5) share the same reservoir (7).

b. **Wrecker Recovery Model M984E1.** Pump (8) mounted on the rear of engine provides the fluid power to operate the power steering (9) and cable tensioner (10). Fluid power for operating the heavy-duty winch (11), self-recovery winch (12), crane (13), and retrieval system (14) is provided by a hydraulic pump (15) driven by the power takeoff mounted on the transmission. Self-recovery winch valve (16) directs hydraulic power to the self-recovery winch (12). Heavy-duty winch control valve (17) directs hydraulic power to the heavy-duty winch (11). Operation of the crane (13) and the retrieval system (14) is controlled from the control panel (18) at the rear of the truck. Both hydraulic pumps (8 and 15) share the same reservoir (19).



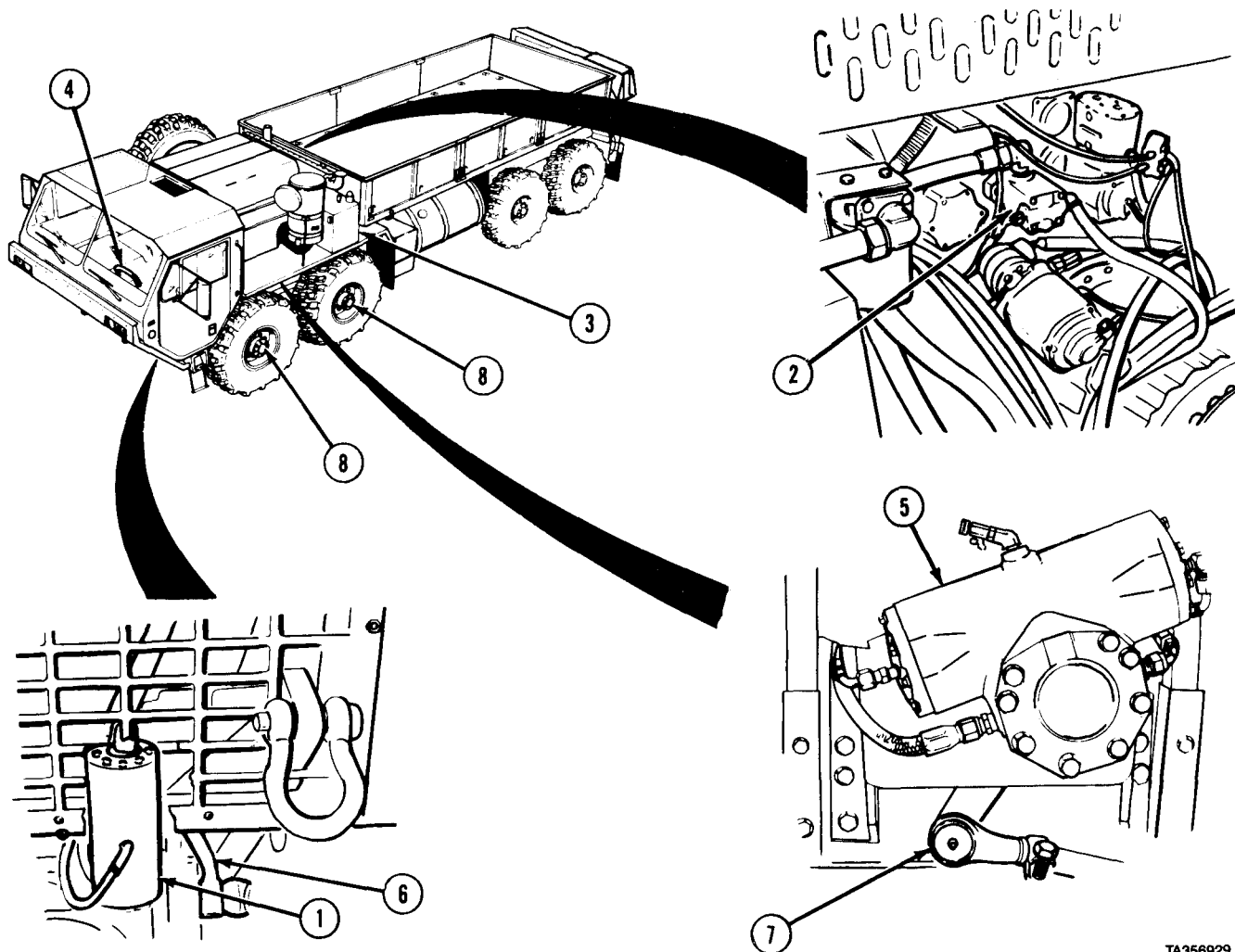
TA356522

Figure 1-15. Hydraulic System

Vehicle Operation Systems (Cont)

1-20. STEERING SYSTEM.

(fig. 1-16) Power is supplied to the main steering gear (1) by an engine driven pump (2). The fluid reservoir (3) is shared with the main hydraulic system. The steering wheel (4), which is mechanically linked to the main steering gear (1), rotates a gear that positions a spool in the main steering gear. This motion is hydraulically transmitted to a piston in the slave gear (5) causing it to follow the rotation of the main gear. The main gear pitman arm (6) is mechanically connected to the slave gear pitman arm (7). These pitman arms move the steering mechanism on the front axles (8) left or right causing the vehicle to steer left or right.

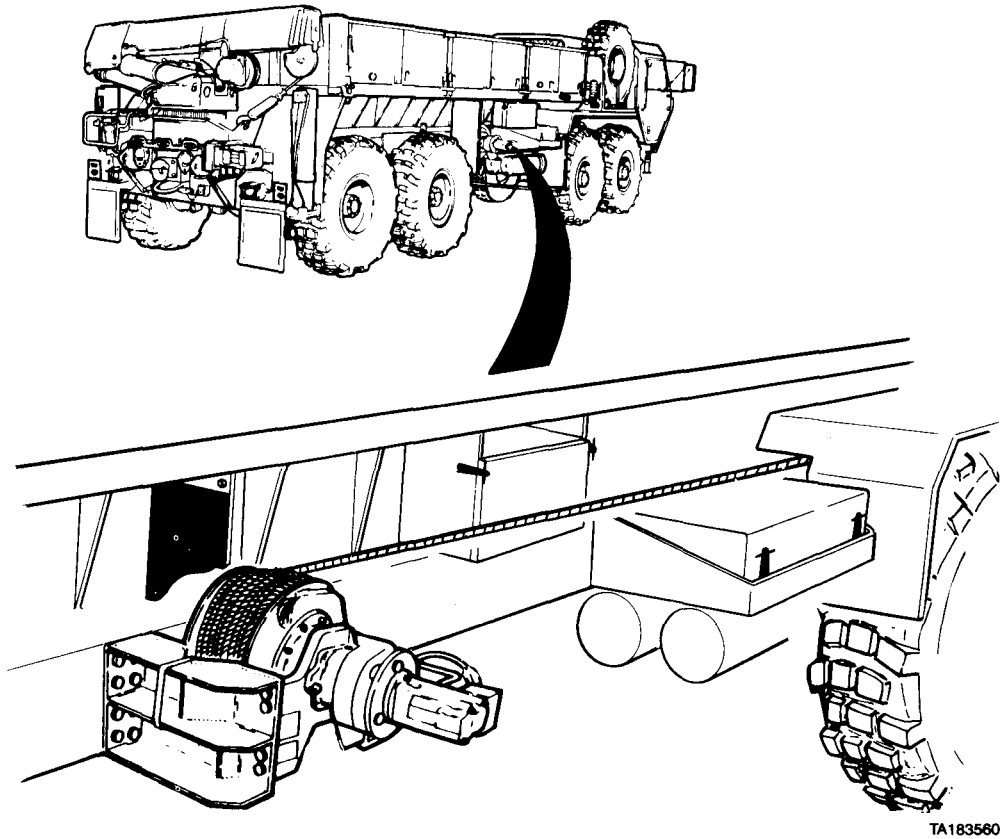


TA356929

Figure 1-16. Steering System.

Vehicle Operation Systems (Cont)

1-21. SELF-RECOVERY WINCH. (fig. 1-17) The self-recovery winch, where used, is mounted on the right side chassis frame rail between the second and third axles. The winch is powered by a reversible hydraulic motor which drives the winch drum through a planetary gearbox. It is equipped with an automatic brake that is applied whenever the cab control lever is in the center position. All vehicles equipped with a self-recovery winch have an operator controlled, two-position valve to activate the reversible winch motor.

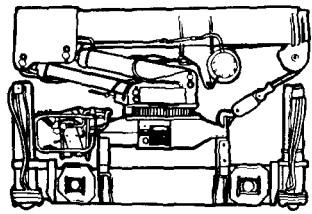


TA183560

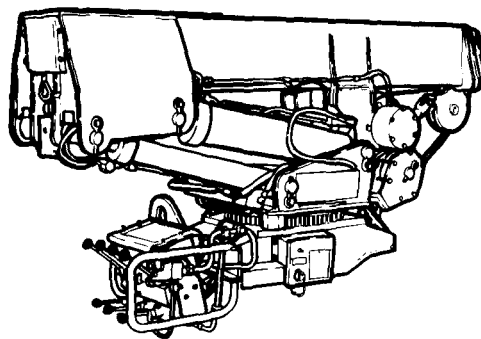
Figure 1-17. Self-Recovery Winch

Vehicle Operation Systems (Cont)

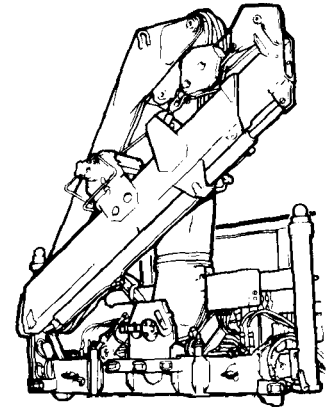
1-22. CRANES. (fig. 1-18) A number of cranes are used on the M977 series vehicles. Refer to operator's manuals for specifications, dimensions and operating procedures for the different crane models. The cranes are completely hydraulic powered and their principles of operation are the same. Individual control panel, boom and hydraulic cylinder arrangements, and lifting capacities are different. All cranes are powered from the vehicle's hydraulic system. All are equipped with outriggers for stability during operation. All cranes use a combination of hinged joints and telescoping members to give them their motions. The hydraulic-powered hoisting winch has an automatic brake to prevent accidental lowering of the load.



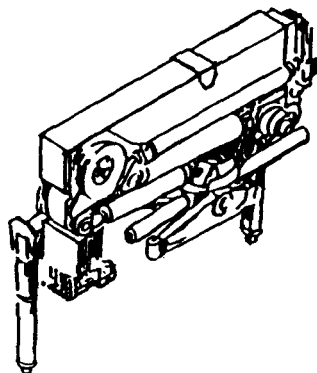
M977 CARGO VEHICLE



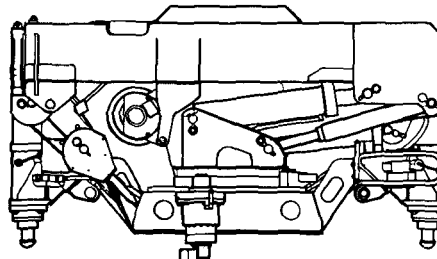
M985 CARGO VEHICLE



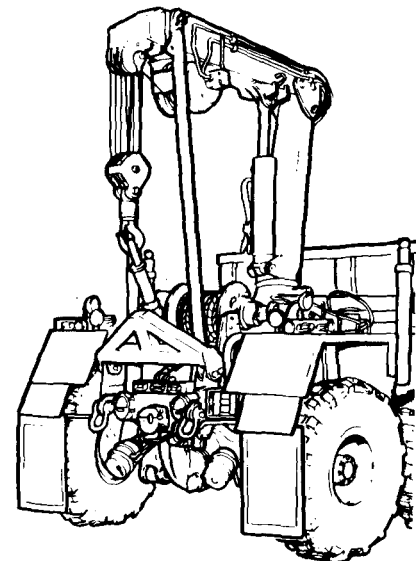
M985E1 CARGO VEHICLE



M983 TRACTOR VEHICLE



**M984E1
WRECKER-RECOVERY VEHICLE**



M984 WRECKER-RECOVERY VEHICLE

TA188459

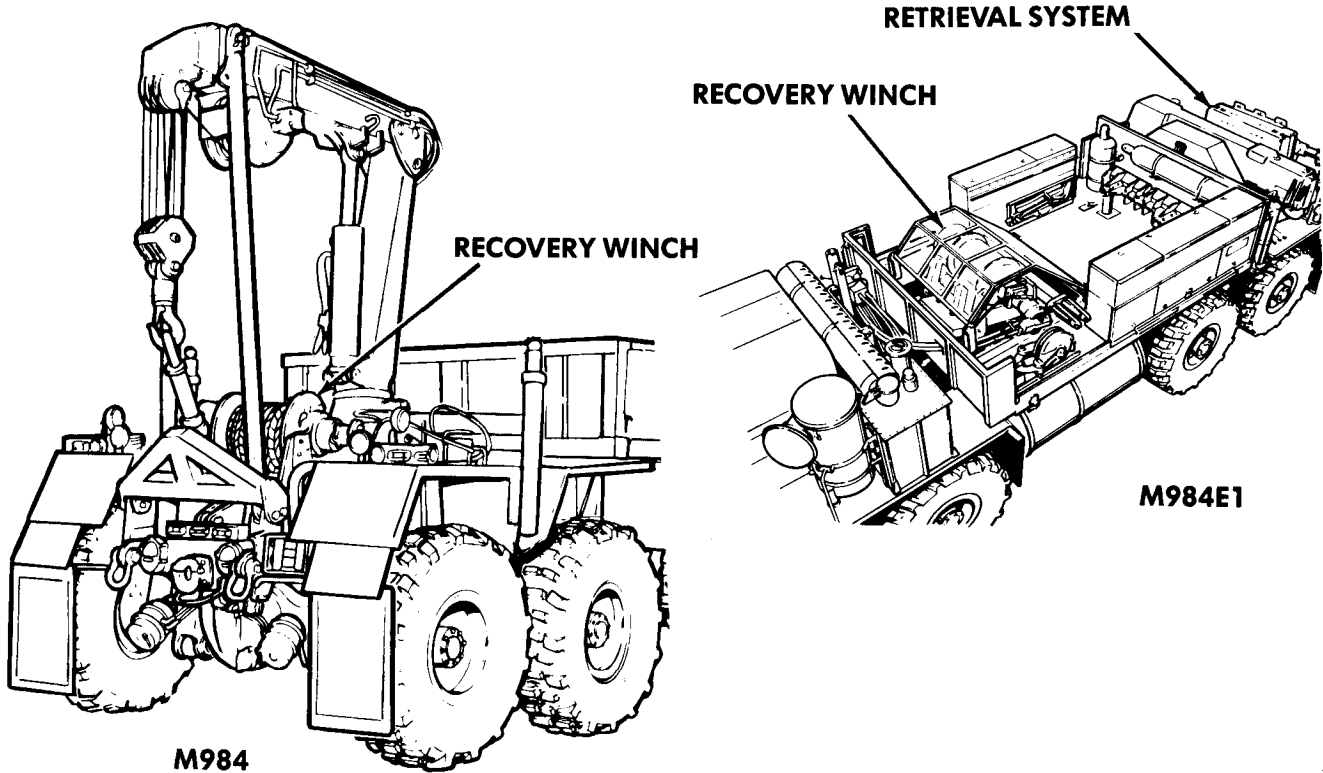
Figure 1-18. Cranes

Vehicle Operation Systems (Cont)

1-23. RECOVERY WINCH (M984 and M984E1) (fig. 1-19) The recovery winch assembly (M984) is mounted on the chassis frame, centered over the fourth axle. It is powered by a hydraulic motor which drives the winch drum through a planetary gearbox. A shift control on the winch permits 2-speed operation.

The recovery winch (M984E1) is mounted on the chassis frame, between the equipment body and crane. It is powered by an automatic 2-speed hydraulic motor which drives the winch drum through a planetary gearbox.

1-24. RETRIEVAL SYSTEM (M984E1) (fig. 1-19) The retrieval system is mounted on the rear frame and is powered from the vehicle hydraulic system. The retrieval system is operator-controlled from the retriever control assembly located above the left rear fender.

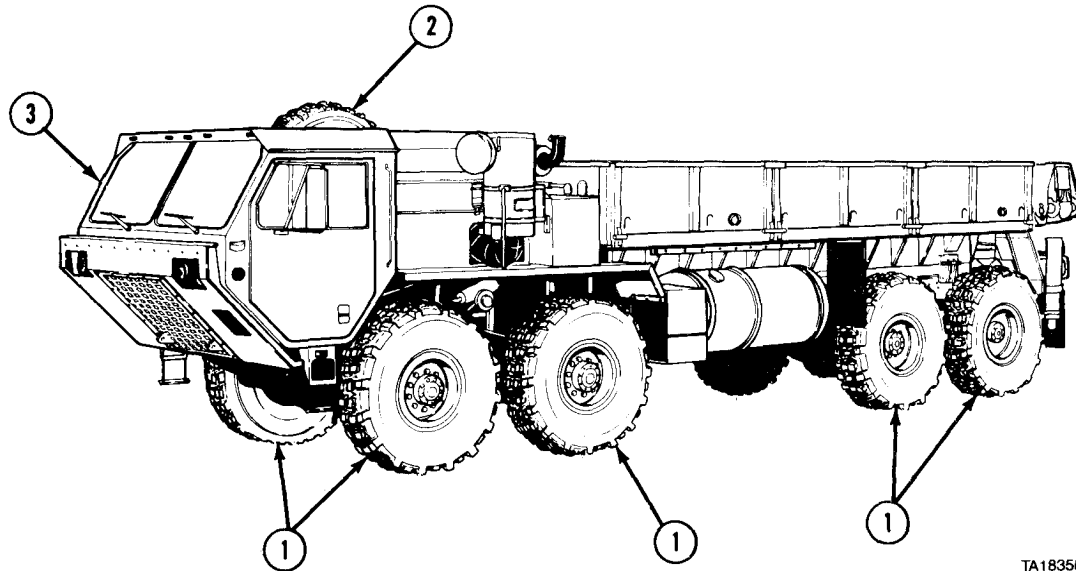


TA100270

Figure 1-19. Recovery Winch (M984 and M984E1).

Vehicle Operation Systems (Cont)

1-25. WHEELS AND TIRES. (fig. 1-20) There are four front and four rear steel disc, 20.00 x 10.00 wheels (1) with 16.00 R20. tube type, radial traction tires. One spare tire (2) is mounted to the right side of vehicle.



TA183561

Figure 1-20. Wheels and Tires.

1-26. CAB. (fig. 1-20) The cab (3) contains all of the driving controls and gages, operating controls for some of the mounted equipment, and adjustable seats for a crew of two. For a detailed explanation of cab controls, refer to TM 9-2320-279-10.

Vehicle Operation Systems (Cont)

1-27. M978 TANKER. (fig. 1-21) The tanker maybe loaded through the manhole (1) in the top or by using the loading valve (2) in the bottom of the tank. A hydraulic motor driven pump (3) is used to deliver fuel during all fueling operations. An electric motor driven pump (4) serves as a backup pumping unit in case the tanker loses hydraulic power. Fuel delivery hoses are stored on retracting reels (5) located on each side of the fueling station. Two reel mounted static grounding cables (6) are provided for grounding whatever is being fueled or defueled. An emergency shutoff valve and a hand-actuated deadman control are included for greater safety. Hand-operated valves attached to the delivery hoses control fuel flow during refueling.

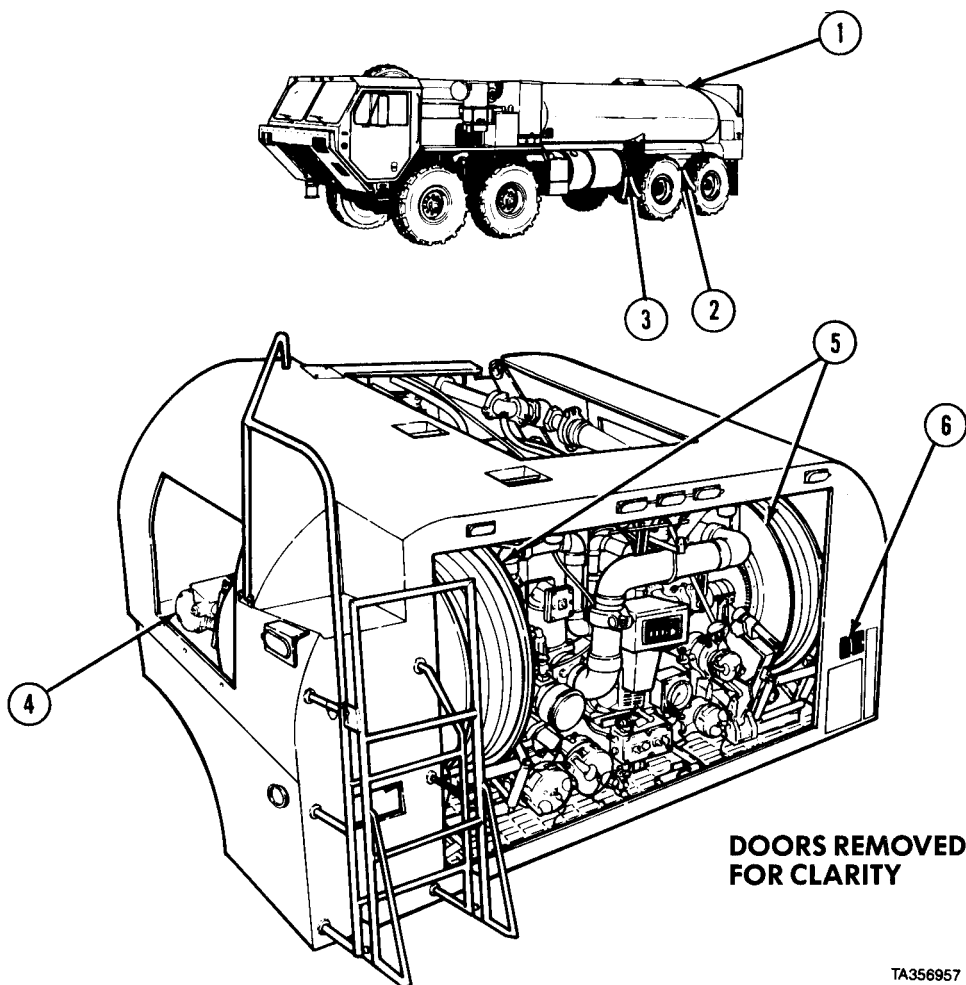


Figure 1-21. Tanker Equipment.

CHAPTER 2 VEHICLE MAINTENANCE

| Contents | Para | Page |
|---|------|-------|
| Scope..... | 2-1 | 2-1 |
| Common Tools and Equipment | 2-2 | 2-1 |
| Special Tools | 2-3 | 2-2 |
| Test Equipment..... | 2-4 | 2-2 |
| Repair Pars..... | 2-5 | 2-2 |
| Unpacking and Deprocessing..... | 2-6 | 2-2 |
| Hand Receipt Manual and Inventory of Equipment..... | 2-7 | 2-3 |
| Service Before Operation..... | 2-8 | 2-2 |
| Preventive Maintenance Checks and Services (PMCS) Introduction..... | 2-9 | 2-3 |
| Maintenance Forms and Records | 2-10 | 2-3 |
| General Maintenance Procedures..... | 2-11 | 2-4 |
| Fluid Leakage..... | 2-12 | 2-5 |
| Preventive Maintenance Checks and Services (PMCS) Tables..... | 2-13 | 2-5 |
| Troubleshooting Introduction..... | 2-14 | 2-50 |
| Troubleshooting Instructions..... | 2-15 | 2-50 |
| Simplified Test Equipment for Internal Combustion Engines (STE/ICE) | | |
| Introduction | 2-17 | 2-334 |
| Maintenance Introduction..... | 2-18 | 2-334 |
| Servicing | 2-19 | 2-335 |
| Ground Handling | 2-20 | 2-335 |
| Inspection of Components..... | 2-21 | 2-336 |
| Cleaning Procedures..... | 2-22 | 2-336 |
| Painting..... | 2-23 | 2-336 |
| Removal and Disassembly of Components..... | 2-24 | 2-337 |
| Lubrication | 2-25 | 2-337 |
| Assembly | 2-26 | 2-337 |
| Installation | 2-27 | 2-337 |
| Adjustment | 2-28 | 2-337 |
| Radio Interference Suppression..... | 2-28 | 2-337 |
| Placing In Service..... | 2-29 | 2-339 |
| Preparation for Storage or Shipment Introduction..... | 2-30 | 2-340 |
| Preparation for Storage or Shipment..... | 2-31 | 2-340 |
| Deleted..... | 2-32 | 2-340 |
| Storage | 2-33 | 2-340 |

Section I. INTRODUCTION

2-1. SCOPE. This chapter provides information on tools, preventive maintenance, troubleshooting, preparation for storage or shipment, and radio interference suppression techniques required to maintain the vehicle.

Section II. REPAIR PARTS, SPECIAL TOOLS, AND TEST, MEASUREMENT, AND DIAGNOSTIC EQUIPMENT (TMDE), AND SUPPORT EQUIPMENT

Parts, Tools, and Test Equipment

2-2. COMMON TOOLS AND EQUIPMENT. There are common tools and general mechanics tool sets required for maintenance of the vehicle. For authorized common tools and equipment, refer to the Modified Table of Organization and Equipment (MTOE) applicable to the unit.

Parts, Tools, and Test Equipment (Cont)

2-3. SPECIAL TOOLS. Special tools for organizational maintenance are listed in TM 9-2320-279-20P which is the authority for requisitioning. The Maintenance Allocation Chart (MAC) (Appendix B) lists special tools needed for the various maintenance tasks.

2-4. TEST EQUIPMENT. The M977 series vehicles are equipped with a connector for Simplified Test Equipment/Internal Combustion Engine (STE/ICE). The STE/ICE connector (1, fig. 2-1) is located on the passenger side of the cab.

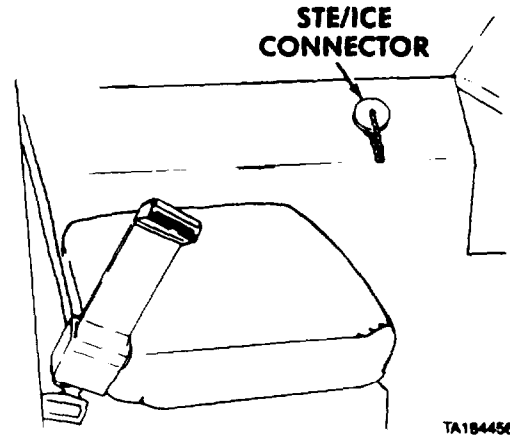


Figure 2-1. STE/ICE Connector.

2-5. REPAIR PARTS. Repair parts authorized for use at organizational level are listed and illustrated in TM 9-2320-279-20P.

Section III. SERVICE UPON RECEIPT

2-6. UNPACKING AND DEPROCESSING.

a. Upon receipt of new vehicle, the receiving organization must see if it has been properly prepared for service and is in good condition. Inspect all assemblies, subassemblies, and accessories to be sure they are in proper working order (TM 9-2320-279-10). Secure, clean, and correctly adjust and/or lubricate as needed (LO 9-2320-279-12). Check all tools and equipment to be sure every item is there, in good condition, clean, and properly mounted or stowed (TM 9-2320-279-10).

b. Read "Processing and Deprocessing Record of Shipping, Storage, and Issue of Vehicles and Spare Engines." tag (DD Form 1397) and follow all precautions checked. This tag should be attached to the steering wheel, shifting lever, or ENGINE START switch.

2-7. HAND RECEIPT MANUAL AND INVENTORY OF EQUIPMENT. When a new vehicle is first received by the using organization, it is necessary to inventory the vehicle equipment. For detailed procedures, refer to Hand Receipt Manual, TM 9-2320-279-10-HR.

2-8. SERVICE BEFORE OPERATION.

a. General.

(1) Upon receipt of new, used, or reconditioned vehicle, the receiving organization must see if it has been properly prepared for service and is in good condition. Inspect all assemblies, subassemblies and accessories to be sure they are in proper working order. Secure, clean, and correctly adjust and/or lubricate as needed. Check all tools and equipment to be sure every item is there, in good condition, clean, and properly mounted or stowed (TM 9-2320-279-10).

(2) Follow general procedures for all services and inspections given in TM 9-2320-279-10.

(3) Refer to TM 9-2320-279-10 for vehicle operating instructions.

STE/ICE Instructions

b. Inspection and Servicing Equipment.

(1) General Procedures.

NOTE

If vehicle has been driven to the using organization, most of all of the following work should have been done.

(a) When vehicle is received, inspect all items for damage that may have occurred during shipping and unloading operations. Pay close attention to any loose or missing nuts, bolts, screws, access plates, drain plugs, draincocks, oil plugs, assemblies, subassemblies, or components that may be easily lost or broken in transit. Check Basic Issue Items (BII) against checklist to make sure all items are accounted for and in good condition. Carefully list all discrepancies (TM 9-2320-279-10-HR).

WARNING

Adhesives, solvents, and sealing compounds can burn easily, can give off harmful vapors, and are harmful to skin and clothing. To avoid injury or death, keep away from fire and use in well-ventilated area. If adhesive, solvents, or sealing compound get on skin or clothing, wash immediately with soap and water.

(b) Clean all exterior surfaces coated with rust-preventive compound with drycleaning solvent.

(2) Special Procedures.

(a) Do the S (six-month or 3,000 mile) Preventive Maintenance Checks and Services (PMCS) (para 2-13).

(b) Lubricate specific points shown in LO 9-2320-279-12 regardless of interval. Do not lubricate gear cases and engine. Check processing tag for gear case and engine oil. If tag states the oil is good for 500 mi (805 K) of operation and is of the proper grade for local climate operation, check oil level but do not change oil.

(a) Schedule an S service in accordance with DA 738-750.

(d) Activate battery if vehicle is delivered with dry-charged battery (TM 9-6140-200-12).

WARNING

Radiator is very hot and pressurized during vehicle operation. Let radiator cool before removing cap. Failure to do so can result in serious burns.

(e) Check radiator coolant. Check if solution is adequate for expected climatic conditions. Refer to TB 750-651 for preparation of antifreeze solutions. Put tag near filler cap with type of antifreeze and degree of protection written on tag.

Section IV. PREVENTIVE MAINTENANCE CHECKS AND SERVICES (PMCS)

PMCS Tables

2-9. PREVENTIVE MAINTENANCE CHECKS AND SERVICES (PMCS) INTRODUCTION. This section contains Unit PMCS requirements for the M977 series vehicles. The PMCS tables contain checks and services necessary to ensure that vehicle is ready for operation. Using the PMCS tables, perform maintenance at the specified intervals. Preventive Maintenance Checks and Services in TM 9-2320-279-10, TM 9-2320-354-10, or TM 9-2320-355-10 must be completed before doing Unit preventive maintenance.

2-10. MAINTENANCE FORMS AND RECORDS. Every mission begins and ends with paperwork. There is not much of it, but it must be kept up. The filled out forms and records have several uses. They are a record of the services, repairs, and modifications made on the vehicle; they are reports to unit maintenance and to the commander; and they serve as a checklist to find out what is wrong with the vehicle after its last use, and whether those faults have been fixed. For information needed on forms and records, see DA PAM 738-750.

2-11. GENERAL MAINTENANCE PROCEDURES.

WARNING

Adhesives, solvents, and sealing compounds can burn easily, can give off harmful vapors, and are harmful to skin and clothing. To avoid injury or death, keep away from fire and use in well-ventilated area. If adhesive, solvents, or sealing compound gets on skin or clothing, wash immediately with soap and water.

a. Cleanliness. Dirt, grease, oil and debris only get in the way and may cover up a serious problem. Use dry cleaning solvent on metal surfaces and soapy water on rubber.

b. Bolts, Nuts, And Screws. Check bolts, nuts, and screws for obvious looseness, missing, bent, or broken condition and tighten or replace as necessary. They cannot all be checked with a tool, of course, but look for chipped paint, bare metal, or rust around bolt heads.

c. Welds. Look for loose or chipped paint, rust, or gaps where parts are welded together. If a bad weld is found, have it repaired.

d. Electric Wires And Connectors. Look for cracked or broken insulation, bare wires, and loose or broken connectors. Tighten loose connectors and make sure the wires are in good shape.

e. Hydraulic Lines And Fittings. Look for wear, damage, leaks, and make sure clamps and fittings are tight. Wet spots show leaks, of course, but a stain around a fitting or connector may indicate a leak. If a connector or fitting is loose, tighten it. If something is broken or worn out, repair or replace per applicable procedure.

2-12. FLUID LEAKAGE. It is necessary to know how fluid leakage affects the status of fuel, oil, coolant, and the hydraulic systems. The following are definitions of types/classes of leakage necessary to know in order to determine the status of the vehicle.

CAUTION

Equipment operation is allowable with minor leakages (Class I or II). Of course, consideration must be given to the field capacity in the item/system being checked/inspected. When in doubt, notify the supervisor. When operating with Class I or II leaks, continue to check fluid levels as required in the PMCS. Class III leaks should be repaired per applicable procedure.

a. Class I. Seepage or fluid as indicated by wetness or discoloration not great enough to form drops.

b. Class II. Leakage of fluid great enough to form drops but not enough to cause drops to drip from item being checked/inspected.

c. Class III. Leakage of fluid great enough to form drops that fall from the item being checked/inspected.

2.13. PREVENTIVE MAINTENANCE CHECKS AND SERVICES (PMCS) TABLES.

a. Do the (S) PREVENTIVE MAINTENANCE once every six months and/or every 3,000 miles (4827 KM) whichever comes first.

b. Do the (A) PREVENTIVE MAINTENANCE once each year and/or every 6,000 miles (19,308 KM) whichever comes first.

c. Do the (B) PREVENTIVE MAINTENANCE once every two years and/or every 12,000 miles (19,308 KM) whichever comes first.

d. Always do the PREVENTIVE MAINTENANCE in the same order until it gets to be a habit. Once practiced, it will be easy to spot anything wrong in a hurry.

e. If something does not work, troubleshoot with instructions in Chapter 2.

f. If anything looks wrong and is not fixed, write a DA Form 2404.

g. When doing preventive maintenance, take along the tools and supplies needed to make all the checks. Always take a clean cloth or two.

NOTE

TABLE 2-1 covers items which are common to all models. Table 2-2 covers items only used on certain models. Table 2-3 covers auxiliary equipment which may be found on any model.

Table 2-1. Unit Level Preventive Maintenance Checks And Services

| Item No. | Interval | Item To Be Inspected | Procedure | Not Mission Capable If: |
|----------|-------------|----------------------|---|--|
| 1 | Semi-Annual | Pre-Service Checks | <p style="text-align: center;">PRIOR TO ROAD TEST</p> <p>Supervise Operator/Crew in performing -10 PMCS listed in TM 9-2320-279-10.</p> <p style="text-align: center;">ROAD TEST</p> <p>Maintenance personnel will be with vehicle operator to assist in performing -10 PMCS checks and verify preservice checks.</p> <p style="text-align: center;">NOTE</p> <p>The following will be performed during the road test. These inspections must be performed before any -20 level PMCS regardless of interval.</p> <p>For road test, vehicle will be driven at least five miles over different ground to give enough time to detect any malfunctions.</p> <p>a. With parking brake applied, and foot off accelerator, place transmission in drive and attempt to start vehicle. If vehicle starts, replace neutral safety switch (para 8-4).</p> <p>a.1. Notice if starter engages smoothly and turns the engine at normal cranking speed.</p> <p>b. Listen for unusual engine noise at idle, at operating speeds, and under acceleration. Be alert for excessive vibration and the smell of oil, fuel or exhaust.</p> <p>c. Check for transmission response to shifting and for smoothness of operation in all speed ranges. Be alert for unusual noises and difficulty in shifting in any speed range.</p> <p>d. Check for transfer case response to shifting and for smoothness of operation in all gear ranges. Be alert for unusual noises and difficulty in shifting in any gear range.</p> <p>e. Test for response to accelerator feed. Observe for sticking pedal.</p> | <p>a.1. Starter inoperative or makes excessive grinding sound.</p> <p>b. Engine knocks, rattles or smokes excessively.</p> <p>c. Transmission shifts improperly, does not shift or makes excessive noises.</p> <p>d. Transfer case jumps out of gear or makes excessive noises.</p> <p>e. Pedal sticking or binding.</p> |

Table 2-1. Unit Level Preventive Maintenance Checks And Services

| Item No. | Interval | Item To Be Inspected | Procedure | Not Mission Capable If: |
|----------|-------------|-------------------------------------|--|---|
| 1 | Semi-Annual | Pre-Service Checks Continued | <p>f. With vehicle speed approximately 5 mph (8 kph) turn steering wheel to left, then right, to detect steering backlash, shimmy or freeplay of more than 1-1/2 inches (38 mm) in either direction. Vehicle should respond instantly. With vehicle moving on straight, level terrain, lightly hold steering wheel to check for pull and wandering.</p> <p>g. Apply brake pedal with steady force. Vehicle should slow down and stop without pulling to one side or jerking. Release brake pedal. The brakes should release immediately and without difficulty.</p> <p>h. Observe vehicle response to road shocks, side sway or continuous bouncing indicates a malfunction.</p> <p style="text-align: center;"><u>AFTER ROAD TEST</u></p> <p>a. Make sure the vehicle has been cleaned of mud, gravel, etc., from the underbody, outside and crew compartment area.</p> <p>b. Perform STE-ICE GO Test: GO2 FIRST PEAR-STARTER GO4 ENGINE START, LUBE GO5 ENGINE W/U COOLANT GO8 COMPRESS UNBALANCE</p> <p style="text-align: center;"><u>CAUTION</u></p> <p>Do not hold steering wheel at full left or right position for longer than 10 seconds. Oil overheating and pump damage can result.</p> <p>c. With vehicle stopped, turn steering wheel to extreme left, then to the extreme right to check for hard steering.</p> <p>d. Check engine operation at all speeds. Ensure that engine does not go over engine governed speed - no load (2175-2275 rpm).</p> | <p>f. Steering binds, grabs, wanders or freeplay is more than 1-1/2 inch (38 mm) in either direction.</p> <p>g. Brakes chatter, pull to one side or inoperative. Brakes will not release.</p> <p>h. Handling is unstable.</p> <p>c. Hard steering is evident.</p> <p>d. Engine governed speed - no load is below 2175 rpms or exceeds 2275.</p> |

Table 2-1. Unit Level Preventive Maintenance Checks and Services

| Item No. | Interval | Item To Be Inspected | Procedure | Not Mission Capable If: |
|----------|-------------|---------------------------|---|--|
| 2 | Semi-Annual | Brake System | <p style="text-align: center;"><u>WARNING</u></p> <p>Brake drum can get very hot during vehicle operation. Place hand near drum to check for excessive heat but do not touch.</p> <p>Carefully check and compare each brake drum for overheating, which can indicate a dragging brake. Cool brake drum could mean improper adjustment, or defective or inoperative brakes.</p> | Brake drums are overheated or excessively cool. |
| 2.1 | Semi-Annual | Body | Inspect body for loose rivets, cracks, loose or missing bolts, and general damage. | Any body damage that would hinder vehicle operation. |
| 3 | Semi-Annual | SR1 and SR2 static cables | <p>Check the resistance of the SR1 static cable (1) from each clip to the following:</p> <ul style="list-style-type: none"> • vehicle frame • tank • grating <p>Check the resistance of the SR2 static cable (2) from each clip to the following:</p> <ul style="list-style-type: none"> • vehicle frame • tank • grating | Resistance is more than 10.5 ohms. |

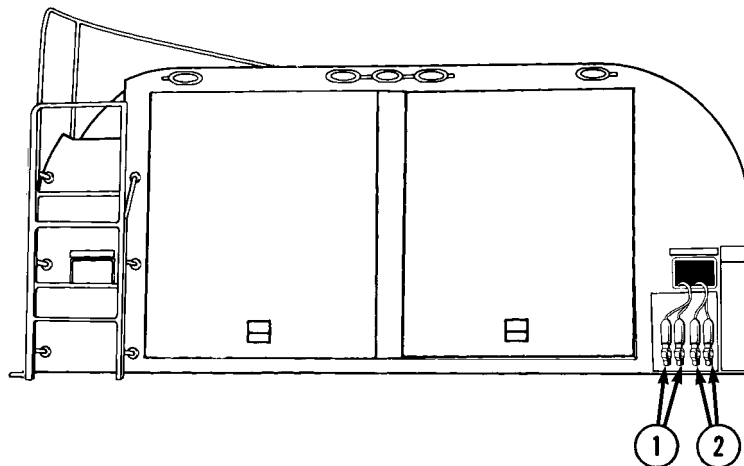


Table 2-1. Unit Level Preventive Maintenance Checks and Services

| Item No. | Interval | Item To Be Inspected | Procedure | Not Mission Capable If: |
|----------|-------------|----------------------|---|---|
| 3.1 | Semi-Annual | Seat Belts | <p style="text-align: center;"><u>WARNING</u></p> <ul style="list-style-type: none"> • Failure to properly inspect and maintain seat belts can cause serious injury or loss of life. • If the replacement of any part of the seat belt is required, the entire belt assembly must be replaced. <p>a. Check for worn webbing (1) at the latch (2) and D-loop (3) areas.</p> <p>b. Check D-loop (3) for free rotation, deformation, cracks, or damage.</p> <p>c. Check comfort latch (4) for proper operation, cracks, and damage.</p> | <p>Webbing is cut, frayed, or excessively worn.</p> <p>D-loop does not rotate freely or is deformed, cracked, or broken.</p> <p>Comfort latch is broken, or does not lock in place easily, and does not release by tugging down on webbing.</p> |

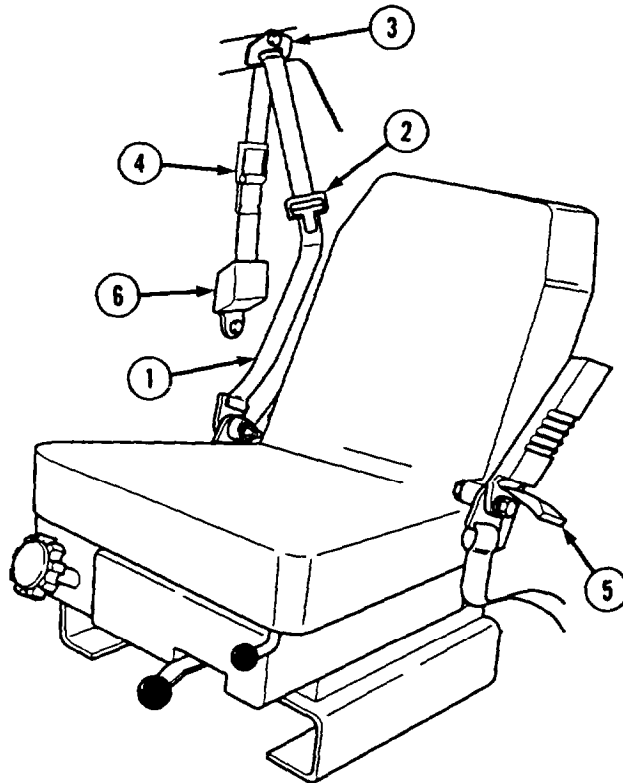


Table 2-1. Unit Level Preventive Maintenance Checks and Services

| Item No. | Interval | Item To Be Inspected | Procedure | Not Mission Capable If: |
|----------|-------------|-------------------------|--|--|
| 3.1 | Semi-Annual | Seat Belts Continued | <p>d. Check latch (2) and buckle (5) for wear, deformation, damage, or broken casing.</p> <p>e. Check latch (2) and buckle (5) for proper operation.</p> <p>f. Check that retractor (6) is not locked up and spools out/retracts webbing (1) properly.</p> <p>g. Check all seat belt mounting hardware for looseness and other damage.</p> | <p>Molded plastic around buckle/latch is deformed, cracked, or broken.</p> <p>Buckle/latch does not engage with a solid sounding "click" and/or does not release freely when button is pushed.</p> <p>Retractor does not operate properly or retractor cover is cracked/broken.</p> <p>Hardware is loose, missing, rusted, corroded, or damaged.</p> |
| 4 | Semi-Annual | Fuel System | <p>a. Inspect fuel filter/water separator assembly for dents and cracks that could cause leaks.</p> <p>b. Replace filter element every 6,000 miles (9,654 km) or semiannually, whichever occurs first. Replace water separator element if un-serviceable.</p> | <p>a. Any Class III leak.</p> <p>b. Fuel filter clogged.</p> |

Table 2-1. Unit Level Preventive Maintenance Checks And Services

| Item No. | Interval | Item To Be Inspected | Procedure | Not Mission Capable If: |
|----------|-------------|-----------------------------|--|--|
| 4 | Semi-Annual | Fuel System Continued | <p>c. Inspect fuel injection pump, nozzle lines, and fittings for leaks and damage.</p> <p>d. Inspect all fuel lines for loose connections, splits, cracks, and kinks that could leak.</p> | <p>c. Rubber cap missing or tom on return line. Any nozzle loose or damaged.</p> <p>d. Any Class III leak.</p> |
| 5 | Semi-Annual | Engine Accessory Drive Belt | <p>a. Check drive belts for cracking, fraying and breaks.</p> <p>b. Check fan belt (paragraph 6-16) and alternator belt (paragraph 6-14) for adjustment.</p> | <p>a. Any drivebelt is missing or broken. Belt fiber has more than one crack (1/8 inch in depth or 50% of belt thickness) or has frays more than 2 inches long.</p> <p>b. Belts adjustment is less than 70 lbs (31 ON) greater than 90 lbs (400N).</p> |
| 6 | Semi-Annual | Cooling System | <p style="text-align: center;"><u>WARNING</u></p> <p>If vehicle has been operating, use extreme care to avoid being burned when removing cooling system radiator cap. Use heavy rags or gloves to protect hands. Turn radiator cap only one-half turn counterclockwise and allow pressure to be relieved before fully removing cap.</p> <p style="text-align: center;">NOTE</p> <p>Coolant level should be up to bottom of filler neck (TM 9-2320-279-10).</p> <p>Use MIL-A-46153 in temperatures above 0° F (-18° C) and MIL-A-11755 in temperatures below 0° F (-18° C).</p> | |

Table 2-1. Unit Level Preventive Maintenance Checks and Services

| Item No. | Interval | Item To Be Inspected | Procedure | Not Mission Capable If: |
|----------|-------------|-----------------------------|--|---|
| 6 | Semi-Annual | Cooling System Continued | <p>a. Check coolant condition. Test coolant to see if draining is necessary (TB 750-651).</p> <p>b. Check all hoses for looseness, splits, wear, and cracks that would cause leaks.</p> <p>c. Inspect hose clamps for wear and serviceability.</p> | <p>a. Coolant condition/testing shows draining is required.</p> <p>b. Class III leakage evident. Hoses are loose or have splits or cracks.</p> <p>c. Hose clamps are worn or unserviceable.</p> |
| 7 | Semi-Annual | PTO Pump | Inspect PTO pump for leaks, cracks, or damage. | Cracks, damage, or Class III leaks. |
| 8 | Semi-Annual | Air Intake System | <p style="text-align: center;"><u>WARNING</u></p> <p>If NBC exposure is suspected, all air filter media should be handled by personnel wearing protective equipment. Consult your unit NBC Officer or NBC NCO for appropriate handling or disposal instructions.</p> <p>a. Inspect air cleaner, hoses, and tubing for proper installation, cracks, breaks, or loose connections that could let unfiltered air get into air intake system.</p> <p>b. Remove air filters (paragraph 4-3) and service. After servicing, reinstall (paragraph 4-3).</p> | <p>a. Cracks, breaks, or loose connections evident.</p> <p>b. Air filters has holes or damaged seal.</p> |
| 9 | Semi-Annual | Exhaust System | <p style="text-align: center;"><u>WARNING</u></p> <p>The exhaust pipe and muffler can become very hot during vehicle operation. Be careful not to touch these parts with bare hands, or allow body to come in contact with pipe or muffler. Exhaust system parts can become hot enough to cause serious burns.</p> <p>a. Inspect exhaust manifold, exhaust pipes, muffler, and tailpipe for corrosion and carbon deposits which may indicate leaks.</p> | <p>a. Evidence of corrosion or carbon deposits evident.</p> |

Table 2-1. Unit Level Preventive Maintenance Checks And Services

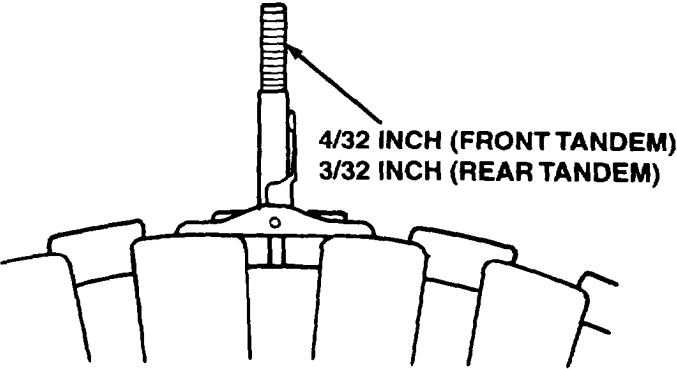
| Item No. | Interval | Item To Be Inspected | Procedure | Not Mission Capable If: |
|----------|-------------|---------------------------------|---|---|
| 9 | Semi-Annual | Exhaust System Continued | b. Inspect for damaged pipes, loose clamps and leaking gaskets or seals. c. Inspect raincap to make sure it operates freely. | b. Pipes damaged, clamps loose, gaskets or seals leaking. c. Raincap does not operate freely, does not close when engine is off, or missing. |
| 10 | Semi-Annual | Tires | a. Check wheel side rings and lockrings for dents, bends or breaks that could cause them to pop off when tires are being inflated. (Refer to TM 9-2320-279-10 para 3-9 for proper inspection procedures). b. Check each tire for nicks, cuts, gouges, objects sticking out, and wear on tread and side-walls.  c. Check each tire for wear using tire depth gage. Three (3) separate measurements must be taken. Measure depth across tread at outside edge, center and inside edge at approximately 12 o'clock, 4 o'clock, and 8 o'clock positions around outside of tire. Tread depth should not be less than 4/32 in. (3.2 mm) (front tandem) 3/32 in. (2.4 mm) (rear tandem). <p style="text-align: center;"><u>WARNING</u></p> Tire air pressure must be checked properly or serious injury or death may result. d. Insure that each tire is properly inflated (see tire pressure chart). (Refer to TM 9-2320-279-10 para 3-9). | |

Table 2-1. Unit Level Preventive Maintenance Checks And Services

| Item No. | Interval | Item To Be Inspected | Procedure | Not Mission Capable If: | | | | | | | | | | | | | | | | | | | | | | | | | | | | | | | | | | | | | | | | | | | | | | | | | | | | | | | | | | | | | | | | | | | | | | | | | | | | | | | | | | | | | | | | | | | | | | | |
|--------------------------------------|----------------------|--------------------------|---|-------------------------|----------------|--------------------------|--------------------------|----------------------|--------------------|--|--|--|--|---------------|---------------------|---------------------|---------------------|---------------------|-----------|---------------------|----|----|---------------------|--------------------------|--|--|--|--|---------------|---------------------|---------------------|---------------------|---------------------|-----------|---------------------|----|----|---------------------|--------|--|--|--|--|---------------|----------------------|----------------------|----------------------|---------------------|-----------|----------------------|----|----|---------------------|--------------------------------------|--|--|--|--|---------------|----------------------|----------------------|----------------------|---------------------|-----------|----------------------|----|----|---------------------|----------------------------|--|--|--|--|---------------|---------------------|---------------------|---------------------|---------------------|-----------|----------------------|----|----|---------------------|-------------------------|--|--|--|--|---------------|----------------------|----------------------|----------------------|----------------------|-----------|----------------------|----|----|----------------------|--|
| 10 | Semi-Annual | Tires Continued | <p>TIRE PRESSURES</p> <table border="1"> <thead> <tr> <th></th> <th><u>Highway</u></th> <th><u>Cross Country-Dry</u></th> <th><u>Cross Country-Wet</u></th> <th><u>Sandy Terrain</u></th> </tr> </thead> <tbody> <tr> <td colspan="5">Front (all models)</td> </tr> <tr> <td>Standard Tire</td> <td>60 psi (414 kPa)</td> <td>35 psi (241 kPa)</td> <td>20 psi (138 kPa)</td> <td>30 psi (207 kPa)</td> </tr> <tr> <td>Sand Tire</td> <td>60 psi (414 kPa)</td> <td>NA</td> <td>NA</td> <td>25 psi (172 kPa)</td> </tr> <tr> <td colspan="5">Rear M977, M978, M983</td> </tr> <tr> <td>Standard Tire</td> <td>70 psi (483 kPa)</td> <td>40 psi (276 kPa)</td> <td>30 psi (207 kPa)</td> <td>35 psi (241 kPa)</td> </tr> <tr> <td>Sand Tire</td> <td>70 psi (483 kPa)</td> <td>NA</td> <td>NA</td> <td>30 psi (207 kPa)</td> </tr> <tr> <td colspan="5">M984E1</td> </tr> <tr> <td>Standard Tire</td> <td>100 psi (690 kPa)</td> <td>100 psi (690 kPa)</td> <td>100 psi (690 kPa)</td> <td>30 psi (207 kPa)</td> </tr> <tr> <td>Sand Tire</td> <td>100 psi (690 kPa)</td> <td>NA</td> <td>NA</td> <td>25 psi (172 kPa)</td> </tr> <tr> <td colspan="5">M984E1 (when towing another vehicle)</td> </tr> <tr> <td>Standard Tire</td> <td>100 psi (690 kPa)</td> <td>100 psi (690 kPa)</td> <td>100 psi (690 kPa)</td> <td>80 psi (552 kPa)</td> </tr> <tr> <td>Sand Tire</td> <td>100 psi (690 kPa)</td> <td>NA</td> <td>NA</td> <td>80 psi (552 kPa)</td> </tr> <tr> <td colspan="5">Front (all models) M985</td> </tr> <tr> <td>Standard Tire</td> <td>90 psi (621 kPa)</td> <td>50 psi (345 kPa)</td> <td>40 psi (276 kPa)</td> <td>40 psi (276 kPa)</td> </tr> <tr> <td>Sand Tire</td> <td>100 psi (690 kPa)</td> <td>NA</td> <td>NA</td> <td>40 psi (276 kPa)</td> </tr> <tr> <td colspan="5">Spare Tire (all models)</td> </tr> <tr> <td>Standard Tire</td> <td>100 psi (690 kPa)</td> <td>100 psi (690 kPa)</td> <td>100 psi (690 kPa)</td> <td>100 psi (690 kPa)</td> </tr> <tr> <td>Sand Tire</td> <td>100 psi (690 kPa)</td> <td>NA</td> <td>NA</td> <td>100 psi (690 kPa)</td> </tr> </tbody> </table> | | <u>Highway</u> | <u>Cross Country-Dry</u> | <u>Cross Country-Wet</u> | <u>Sandy Terrain</u> | Front (all models) | | | | | Standard Tire | 60 psi (414 kPa) | 35 psi (241 kPa) | 20 psi (138 kPa) | 30 psi (207 kPa) | Sand Tire | 60 psi (414 kPa) | NA | NA | 25 psi (172 kPa) | Rear M977, M978, M983 | | | | | Standard Tire | 70 psi (483 kPa) | 40 psi (276 kPa) | 30 psi (207 kPa) | 35 psi (241 kPa) | Sand Tire | 70 psi (483 kPa) | NA | NA | 30 psi (207 kPa) | M984E1 | | | | | Standard Tire | 100 psi (690 kPa) | 100 psi (690 kPa) | 100 psi (690 kPa) | 30 psi (207 kPa) | Sand Tire | 100 psi (690 kPa) | NA | NA | 25 psi (172 kPa) | M984E1 (when towing another vehicle) | | | | | Standard Tire | 100 psi (690 kPa) | 100 psi (690 kPa) | 100 psi (690 kPa) | 80 psi (552 kPa) | Sand Tire | 100 psi (690 kPa) | NA | NA | 80 psi (552 kPa) | Front (all models) M985 | | | | | Standard Tire | 90 psi (621 kPa) | 50 psi (345 kPa) | 40 psi (276 kPa) | 40 psi (276 kPa) | Sand Tire | 100 psi (690 kPa) | NA | NA | 40 psi (276 kPa) | Spare Tire (all models) | | | | | Standard Tire | 100 psi (690 kPa) | 100 psi (690 kPa) | 100 psi (690 kPa) | 100 psi (690 kPa) | Sand Tire | 100 psi (690 kPa) | NA | NA | 100 psi (690 kPa) | |
| | <u>Highway</u> | <u>Cross Country-Dry</u> | <u>Cross Country-Wet</u> | <u>Sandy Terrain</u> | | | | | | | | | | | | | | | | | | | | | | | | | | | | | | | | | | | | | | | | | | | | | | | | | | | | | | | | | | | | | | | | | | | | | | | | | | | | | | | | | | | | | | | | | | | | | | | |
| Front (all models) | | | | | | | | | | | | | | | | | | | | | | | | | | | | | | | | | | | | | | | | | | | | | | | | | | | | | | | | | | | | | | | | | | | | | | | | | | | | | | | | | | | | | | | | | | | | | | | | | | | |
| Standard Tire | 60 psi (414 kPa) | 35 psi (241 kPa) | 20 psi (138 kPa) | 30 psi (207 kPa) | | | | | | | | | | | | | | | | | | | | | | | | | | | | | | | | | | | | | | | | | | | | | | | | | | | | | | | | | | | | | | | | | | | | | | | | | | | | | | | | | | | | | | | | | | | | | | | |
| Sand Tire | 60 psi (414 kPa) | NA | NA | 25 psi (172 kPa) | | | | | | | | | | | | | | | | | | | | | | | | | | | | | | | | | | | | | | | | | | | | | | | | | | | | | | | | | | | | | | | | | | | | | | | | | | | | | | | | | | | | | | | | | | | | | | | |
| Rear M977, M978, M983 | | | | | | | | | | | | | | | | | | | | | | | | | | | | | | | | | | | | | | | | | | | | | | | | | | | | | | | | | | | | | | | | | | | | | | | | | | | | | | | | | | | | | | | | | | | | | | | | | | | |
| Standard Tire | 70 psi (483 kPa) | 40 psi (276 kPa) | 30 psi (207 kPa) | 35 psi (241 kPa) | | | | | | | | | | | | | | | | | | | | | | | | | | | | | | | | | | | | | | | | | | | | | | | | | | | | | | | | | | | | | | | | | | | | | | | | | | | | | | | | | | | | | | | | | | | | | | | |
| Sand Tire | 70 psi (483 kPa) | NA | NA | 30 psi (207 kPa) | | | | | | | | | | | | | | | | | | | | | | | | | | | | | | | | | | | | | | | | | | | | | | | | | | | | | | | | | | | | | | | | | | | | | | | | | | | | | | | | | | | | | | | | | | | | | | | |
| M984E1 | | | | | | | | | | | | | | | | | | | | | | | | | | | | | | | | | | | | | | | | | | | | | | | | | | | | | | | | | | | | | | | | | | | | | | | | | | | | | | | | | | | | | | | | | | | | | | | | | | | |
| Standard Tire | 100 psi (690 kPa) | 100 psi (690 kPa) | 100 psi (690 kPa) | 30 psi (207 kPa) | | | | | | | | | | | | | | | | | | | | | | | | | | | | | | | | | | | | | | | | | | | | | | | | | | | | | | | | | | | | | | | | | | | | | | | | | | | | | | | | | | | | | | | | | | | | | | | |
| Sand Tire | 100 psi (690 kPa) | NA | NA | 25 psi (172 kPa) | | | | | | | | | | | | | | | | | | | | | | | | | | | | | | | | | | | | | | | | | | | | | | | | | | | | | | | | | | | | | | | | | | | | | | | | | | | | | | | | | | | | | | | | | | | | | | | |
| M984E1 (when towing another vehicle) | | | | | | | | | | | | | | | | | | | | | | | | | | | | | | | | | | | | | | | | | | | | | | | | | | | | | | | | | | | | | | | | | | | | | | | | | | | | | | | | | | | | | | | | | | | | | | | | | | | |
| Standard Tire | 100 psi (690 kPa) | 100 psi (690 kPa) | 100 psi (690 kPa) | 80 psi (552 kPa) | | | | | | | | | | | | | | | | | | | | | | | | | | | | | | | | | | | | | | | | | | | | | | | | | | | | | | | | | | | | | | | | | | | | | | | | | | | | | | | | | | | | | | | | | | | | | | | |
| Sand Tire | 100 psi (690 kPa) | NA | NA | 80 psi (552 kPa) | | | | | | | | | | | | | | | | | | | | | | | | | | | | | | | | | | | | | | | | | | | | | | | | | | | | | | | | | | | | | | | | | | | | | | | | | | | | | | | | | | | | | | | | | | | | | | | |
| Front (all models) M985 | | | | | | | | | | | | | | | | | | | | | | | | | | | | | | | | | | | | | | | | | | | | | | | | | | | | | | | | | | | | | | | | | | | | | | | | | | | | | | | | | | | | | | | | | | | | | | | | | | | |
| Standard Tire | 90 psi (621 kPa) | 50 psi (345 kPa) | 40 psi (276 kPa) | 40 psi (276 kPa) | | | | | | | | | | | | | | | | | | | | | | | | | | | | | | | | | | | | | | | | | | | | | | | | | | | | | | | | | | | | | | | | | | | | | | | | | | | | | | | | | | | | | | | | | | | | | | | |
| Sand Tire | 100 psi (690 kPa) | NA | NA | 40 psi (276 kPa) | | | | | | | | | | | | | | | | | | | | | | | | | | | | | | | | | | | | | | | | | | | | | | | | | | | | | | | | | | | | | | | | | | | | | | | | | | | | | | | | | | | | | | | | | | | | | | | |
| Spare Tire (all models) | | | | | | | | | | | | | | | | | | | | | | | | | | | | | | | | | | | | | | | | | | | | | | | | | | | | | | | | | | | | | | | | | | | | | | | | | | | | | | | | | | | | | | | | | | | | | | | | | | | |
| Standard Tire | 100 psi (690 kPa) | 100 psi (690 kPa) | 100 psi (690 kPa) | 100 psi (690 kPa) | | | | | | | | | | | | | | | | | | | | | | | | | | | | | | | | | | | | | | | | | | | | | | | | | | | | | | | | | | | | | | | | | | | | | | | | | | | | | | | | | | | | | | | | | | | | | | | |
| Sand Tire | 100 psi (690 kPa) | NA | NA | 100 psi (690 kPa) | | | | | | | | | | | | | | | | | | | | | | | | | | | | | | | | | | | | | | | | | | | | | | | | | | | | | | | | | | | | | | | | | | | | | | | | | | | | | | | | | | | | | | | | | | | | | | | |

Table 2-1. Unit Level Preventive Maintenance Checks And Services

| Item No. | Interval | Item To Be Inspected | Procedure | Not Mission Capable If: | | | | | | | | | | | | | | | | | | | | | | | | | | | | | | | | | | | |
|--------------------------------------|------------------------------------|--------------------------------|---|-------------------------|------------------------------------|-------------------------|--------------------------------|--------------------------------|--------------------------------|--|--|--|--|---------------|--------------------|--------------------|--------------------|--------------------|-----------|--------------------|----|----|--------------------|--------------------------------------|--|--|--|--|---------------|---------------------|--------------------|--------------------|--------------------|-----------|---------------------|----|----|--------------------|--|
| 10 | Semi-Annual | Tires Continued | <p>OPERATING SPEEDS</p> <table border="1"> <thead> <tr> <th></th> <th>Highway</th> <th>Cross Country-Dry</th> <th>Cross Country-Wet</th> <th>Sandy Terrain</th> </tr> </thead> <tbody> <tr> <td>Maximum Speed (all models)</td> <td></td> <td></td> <td></td> <td></td> </tr> <tr> <td>Standard Tire</td> <td>55 mph (88 kmh)</td> <td>40 mph (64 kmh)</td> <td>20 mph (32 kmh)</td> <td>20 mph (32 kmh)</td> </tr> <tr> <td>Sand Tire</td> <td>55 mph (88 kmh)</td> <td>NA</td> <td>NA</td> <td>20 mph (32 kmh)</td> </tr> <tr> <td>M984E1 (when towing another vehicle)</td> <td></td> <td></td> <td></td> <td></td> </tr> <tr> <td>Standard Tire</td> <td>15 mph (24 kmh)*</td> <td>15 mph (24 kmh)</td> <td>15 mph (24 kmh)</td> <td>15 mph (24 kmh)</td> </tr> <tr> <td>Sand Tire</td> <td>15 mph (24 kmh)*</td> <td>NA</td> <td>NA</td> <td>15 mph (24 kmh)</td> </tr> </tbody> </table> <p>* Operation at speeds over 15 mph (24 kmh) on paved road can be achieved when the operator determines that the vehicle being towed and the terrain allow for safe operation. Under no condition can speeds exceed 35 mph (55 kmh) on paved roads and 15 mph (24 kmh) off paved roads.</p> <p>NOTE</p> <p>Tires should only be rotated on the same side within same tandem.</p> <p>e. Rotate tires. Switch tires on No. 1 and No. 2 axles on right side. Switch tires on No. 3 and No. 4 axles on right side. Switch tires on No. 1 and No. 2 axles on left side. Switch tires on No. 3 and No. 4 axles on left side.</p> <p>f. Make sure all wheel lugnuts are installed and tightened to correct torque value.</p> | | Highway | Cross Country-Dry | Cross Country-Wet | Sandy Terrain | Maximum Speed (all models) | | | | | Standard Tire | 55 mph (88 kmh) | 40 mph (64 kmh) | 20 mph (32 kmh) | 20 mph (32 kmh) | Sand Tire | 55 mph (88 kmh) | NA | NA | 20 mph (32 kmh) | M984E1 (when towing another vehicle) | | | | | Standard Tire | 15 mph (24 kmh)* | 15 mph (24 kmh) | 15 mph (24 kmh) | 15 mph (24 kmh) | Sand Tire | 15 mph (24 kmh)* | NA | NA | 15 mph (24 kmh) | |
| | Highway | Cross Country-Dry | Cross Country-Wet | Sandy Terrain | | | | | | | | | | | | | | | | | | | | | | | | | | | | | | | | | | | |
| Maximum Speed (all models) | | | | | | | | | | | | | | | | | | | | | | | | | | | | | | | | | | | | | | | |
| Standard Tire | 55 mph (88 kmh) | 40 mph (64 kmh) | 20 mph (32 kmh) | 20 mph (32 kmh) | | | | | | | | | | | | | | | | | | | | | | | | | | | | | | | | | | | |
| Sand Tire | 55 mph (88 kmh) | NA | NA | 20 mph (32 kmh) | | | | | | | | | | | | | | | | | | | | | | | | | | | | | | | | | | | |
| M984E1 (when towing another vehicle) | | | | | | | | | | | | | | | | | | | | | | | | | | | | | | | | | | | | | | | |
| Standard Tire | 15 mph (24 kmh)* | 15 mph (24 kmh) | 15 mph (24 kmh) | 15 mph (24 kmh) | | | | | | | | | | | | | | | | | | | | | | | | | | | | | | | | | | | |
| Sand Tire | 15 mph (24 kmh)* | NA | NA | 15 mph (24 kmh) | | | | | | | | | | | | | | | | | | | | | | | | | | | | | | | | | | | |
| | | | <table border="1"> <thead> <tr> <th>FRONT WHEELS</th> <th>REAR WHEELS (ALL EXCEPT M984E1)</th> <th>REAR WHEELS (M984E1)</th> </tr> </thead> <tbody> <tr> <td>575-625 lb-ft (780-848 N•m)</td> <td>450-500 lb-ft (610-678 N•m)</td> <td>575-625 lb-ft (780-848 N•m)</td> </tr> </tbody> </table> | FRONT WHEELS | REAR WHEELS (ALL EXCEPT M984E1) | REAR WHEELS (M984E1) | 575-625 lb-ft (780-848 N•m) | 450-500 lb-ft (610-678 N•m) | 575-625 lb-ft (780-848 N•m) | | | | | | | | | | | | | | | | | | | | | | | | | | | | | | |
| FRONT WHEELS | REAR WHEELS (ALL EXCEPT M984E1) | REAR WHEELS (M984E1) | | | | | | | | | | | | | | | | | | | | | | | | | | | | | | | | | | | | | |
| 575-625 lb-ft (780-848 N•m) | 450-500 lb-ft (610-678 N•m) | 575-625 lb-ft (780-848 N•m) | | | | | | | | | | | | | | | | | | | | | | | | | | | | | | | | | | | | | |

Table 2-1. Unit Level Preventive Maintenance Checks and Services

| Item No. | Interval | Item To Be Inspected | Procedure | Not Mission Capable If: |
|----------|-------------|----------------------|---|---|
| 11 | Semi-Annual | Transmission | <p style="text-align: center;">NOTE</p> <p>After expiration of warranty, active Army units will send an oil sample to an AOAP Laboratory for analysis every 100 hours of operation or 60 days, whichever comes first. Reserve and National Guard Activities will send an oil sample to an AOAP Laboratory for analysis every 100 hours of operation or 120 days, whichever comes first.</p> <p style="text-align: center;">NOTE</p> <p>Oil and oil filter will be changed only when they are known to be contaminated, clogged, or when service is recommended by AOAP laboratory.</p> <p style="text-align: center;">NOTE</p> <p>When AOAP laboratory support is not available, change oil and oil filter at 6,000 miles (9,654 km) or six months.</p> <p style="text-align: center;">COLD TEMPERATURE OPERATION</p> <p>For operating of equipment in expected continuous temperatures below 0° F (-18° C), remove lubricants prescribed in the key for temperatures above 0° F (-18° C). Relubricate with lubricants specified in the key for temperatures 0° F to -50° F (-18° C to -46° C).</p> <p>a. Check transmission for cracks, loose bolts, leaks and obvious damage.</p> <p>b. Check transmission oil pan bolts and drain plug for looseness.</p> <p>c. Inspect transmission output shaft seal for damage and leaks.</p> <p>d. Inspect transmission shift cable for kinks, excessive play, wear or damage.</p> | <p>Faulty oil results received from AOAP lab. "Do not operate".</p> <p>a. Cracks, loose bolts, or Class III leaks evident.</p> <p>b. Loose oil pan bolts or drain plug.</p> <p>c. Damage or Class III leaks evident.</p> <p>d. Kinks, excessive play or wear evident.</p> |

Table 2-1. Unit Level Preventive Maintenance Checks And Services

| Item No. | Interval | Item To Be Inspected | Procedure | Not Mission Capable If: |
|----------|-------------|----------------------|--|---|
| 12 | Semi-Annual | Transfer Case | <p>a. Check oil level and fill with OE/HDO at fill plug as required.</p> <p>b. Check oil seals for damage and leaks.</p> <p>c. Check transfer case for leaks, cracks, damage, and loose bolts.</p> <p style="text-align: center;"><u>WARNING</u></p> <p>Adhesives, solvents, and sealing compounds can burn easily, can give off harmful vapors, and are harmful to skin and clothing. To avoid injury or death, keep away from fire and use in well-ventilated area. If adhesive, solvents, or sealing compound get on skin or clothing, wash immediately with soap and water.</p> <p>d. Remove breather from transfer case. Wash breather in solvent and allow to air dry.</p> <p>e. Coat threads with pipe thread sealing compound and install transfer case breather.</p> | <p>b. Class III leak.</p> <p>c. Class III leak or cracks, damage, loose bolts evident.</p> <p>d. Breather missing or cannot be cleaned.</p> |
| 13 | Semi-Annual | Rear Axles | <p style="text-align: center;">NOTE</p> <p>COLD TEMPERATURE OPERATION</p> <p>For operation of equipment in expected continuous temperatures below 0° F (-18° C), remove lubricants prescribed in the key for temperatures above 0° F (-18° C). Relubricate with lubricants specified in the key for temperatures 0° F to -50° F (-18° C to -46° C).</p> | |

Table 2-1. Unit Level Preventive Maintenance Checks and Services

| Item No. | Interval | Item To Be Inspected | Procedure | Not Mission Capable If: |
|----------|-------------|-----------------------------|---|-------------------------|
| 13 | Semi-Annual | Rear Axles Continued | <p style="text-align: center;">NOTE</p> <ul style="list-style-type: none"> • Change lubricant in new or rebuilt axles within 1,000 miles (1,600 km) but no sooner than 500 miles (800 km). Following initial drain, change lubricant every 12,000 miles (18,000 km) or 2 years of service, whichever comes first. During all lubricant changes, remove metal particles from magnetic drain an filler plugs. • When filling No. 3 and No. 4 differentials, fill to bottom of CHECK and FILL hole, then raise one end of axle 8 inches (203 mm) to allow lubricant to flow out to the wheel bearing, Lower the axle and refill. Raise other end of axle the same way, then lower and refill again. <p>a. Check and refill No. 3 axle differential with GO as required.</p> <p>b. Check lubricant level of No. 3 axle Power Divider. Fill with GO as required at fill plug.</p> <p>c. Check No. 4 axle differential lube level. Fill with GO as required.</p> <p style="text-align: center;">NOTE</p> <p style="text-align: center;">SPRING HANGERS</p> <p>If spring hangers pin does not accept grease, relieve load on spring pin by jacking up by frame rails as close to spring pin as possible. If spring pin still fails to take grease, notify Direct Support maintenance to remove spring pin and/or bushing and replace if necessary.</p> <p>d. Lubricate No. 3 and No. 4 axle spring pivots with GAA.</p> | |

Table 2-1. Unit Level Preventive Maintenance Checks And Services

| Item No. | Interval | Item To Be Inspected | Procedure | Not Mission Capable If: |
|----------|-------------|-----------------------|---|---|
| 14 | Semi-Annual | Axle Housing Breather | <p style="text-align: center;"><u>WARNING</u></p> <p>Adhesives, solvents, and sealing compounds can burn easily, can give off harmful vapors, and are harmful to skin and clothing. To avoid injury or death, keep away from fire and use in well-ventilated area. If adhesive, solvents, or sealing compound get on skin or clothing, wash immediately with soap and water.</p> <p>a. Remove breather from axle housing. Wash breather in solvent and allow to air dry.</p> <p>b. Coat threads with pipe thread sealing compound and install axle housing breather.</p> | Axle breather missing or cannot be cleaned. |

Table 2-1. Unit Level Preventive Maintenance Checks and Services

| Item No. | Interval | Item To Be Inspected | Procedure | Not Mission Capable If: |
|----------|-------------|----------------------|--|-------------------------|
| 15 | Semi-Annual | Front Axles | <p style="text-align: center;">NOTE</p> <p style="text-align: center;">COLD TEMPERATURE OPERATION</p> <p>For operation of equipment in expected continuous temperatures below 0° F (-18° C), remove lubricants prescribed in the key for temperatures above 0° F (-18° C). Relubricate with lubricants specified in the key for temperatures 0° F to -50° F (-18° C to -46° C).</p> <p style="text-align: center;">NOTE</p> <ul style="list-style-type: none"> • Change lubricant in new or rebuilt axles within 1,000 miles (1,600 km) but no sooner than 500 miles (800 km). Following initial drain, change lubricant every 12,000 miles (19,308 km) or 2 years of service, whichever comes first. During all lubricant changes, remove metal particles from magnetic drain and filler plugs. • During lubricant changes on No. 2 axles, clean the tube pump filter screen. To completely drain No. 2 axles, remove the plug at bottom of power divider in addition to drain plug in bottom of differential housing. • Fill No. 1 and No. 2 differential housings to a level even with bottom of CHECK and FILL plug hole. <ul style="list-style-type: none"> a. Check lubricant level of axle No. 1 and No. 2 differential. Fill as necessary with GO. <p style="text-align: center;">NOTE</p> <p style="text-align: center;">SPRING HANGERS</p> <p>If spring hangers pin does not accept grease, relieve load on spring pin by jacking up by frame rails as close to spring pin as possible. If spring pin still fails to take grease, notify Direct Support maintenance to remove spring pin and/or bushing. Replace if necessary.</p> | |

Table 2-1. Unit Level Preventive Maintenance Checks And Services

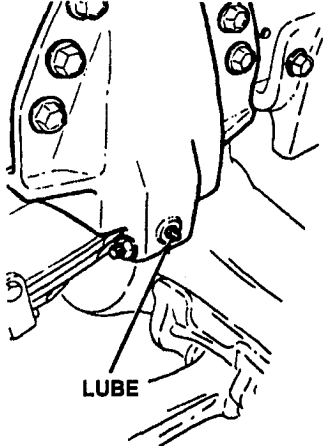
| Item No. | Interval | Item To Be Inspected | Procedure | Not Mission Capable If: |
|----------|-------------|------------------------------|--|---|
| 15 | Semi-Annual | Front Axles Continued | <p>b. Lubricate the No. 1 and No. 2 axle spring pivots with GAA.</p>  <p>c. Check lubricant level at check plug of No. 2 axle power divider. Fill with GO at fill plug as required.</p> <p style="text-align: center;"><u>WARNING</u></p> <p>Adhesives, solvents, and sealing compounds can burn easily, can give off harmful vapors, and are harmful to skin and clothing. To avoid injury or death, keep away from fire and use in well-ventilated area. If adhesive, solvents, or sealing compound get on skin or clothing, wash immediately with soap and water.</p> <p>d. Remove breather from axle housing. Wash breather in solvent and allow to air dry.</p> | <p>d. Axle breather missing or cannot be cleaned.</p> |

Table 2-1. Unit Level Preventive Maintenance Checks and Services

| Item No. | Interval | Item To Be Inspected | Procedure | Not Mission Capable If: |
|----------|-------------|------------------------------|---|--|
| 15 | Semi-Annual | Front Axles Continued | <p>e. Coat threads with pipe thread sealing compound and install axle housing breather.</p> <p>f. Inspect each input and output shaft seal for damage and leaks.</p> <p>g. Inspect trunnion bearing for damage and wear (paragraph 10-3).</p> <p style="text-align: center;">NOTE</p> <p>To complete lubrication of front axle's trunnion bearing, add 8-10 squirts of GAA to top and bottom.</p> <p>h. Lubricate the No. 1 and No. 2 axle trunnion bearings with GAA.</p> <p>i. Check each front axle ball joint for excessive grease. Excessive grease indicates worn or damaged wiper seal.</p> | <p>f. Damage or Class III leaks evident.</p> <p>g. Damage or wear evident.</p> <p>i. Class III leak evident.</p> |
| 16 | Semi-Annual | Fuel System | <p style="text-align: center;"><u>WARNING</u></p> <p>Adhesives, solvents, and sealing compounds can burn easily, can give off harmful vapors, and are harmful to skin and clothing. To avoid injury or death, keep away from fire and use in well-ventilated area. If adhesive, solvents, or sealing compound get on skin or clothing, wash immediately with soap and water.</p> <p>a. Inspect fuel tank straps, brackets and liners, using the following instructions.</p> <ol style="list-style-type: none"> 1. Inspect fuel tank brackets and straps for cracks, breaks, and badly rusted areas. 2. Inspect bracket liners for brittleness, cracks and breaks. 3. Purge clean fuel tank (TB 43-0212), if required. | |

Table 2-1. Unit Level Preventive Maintenance Checks And Service

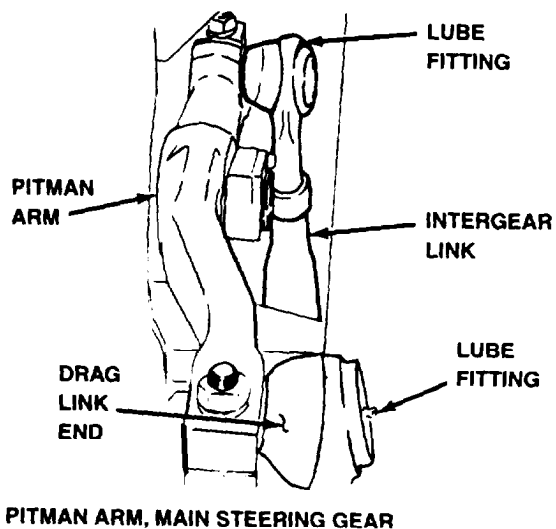
| Item No. | Interval | Item To Be Inspected | Procedure | Not Mission Capable If: |
|----------|-------------|------------------------------|--|--|
| 16 | Semi-Annual | Fuel System Continued | 4. Inspect fuel tank for cracks, broken welds, and stripped threads. b. Check fuel lines and fittings for leaks. | b. Class III leaks evident. |
| 17 | Semi-Annual | Compressed Air System | <p style="text-align: center;">NOTE</p> In areas where more than approximately 30° range of temperature is common, small amounts of water can accumulate in the air brake system due to condensation. The presence of small amounts of water due to condensation is normal. a. Drain air tanks. If any moisture is forced out, inspect air dryer and replace filter (paragraph 11-22). If moisture is milky, blue or green, serious internal malfunctions are indicated. b. Inspect four air reservoirs, attaching valves, lines and connections for mounting looseness, bends, dents, and cracks that could cause leaks. | a. Moisture is milky, blue or green. b. Bends, dents, cracks, loose air lines or air leaks evident. |
| 18 | Semi-Annual | Steering Assembly | <p style="text-align: center;">NOTE</p> When using a grease gun, apply lubricant to the fitting until clean lubricant squeezes out of the part being lubricated. a. Lubricate the intergear link with GAA. b. Lubricate the No. 1 axle drag link with GAA. c. Lubricate the No. 2 axle drag link with GAA. | a. Fittings will not purge old lubricant out of component. b. Fittings will not purge old lubricant out of component. c. Fittings will not purge old lubricant out of component. |

Table 2-1. Unit Level Preventive Maintenance Checks and Services

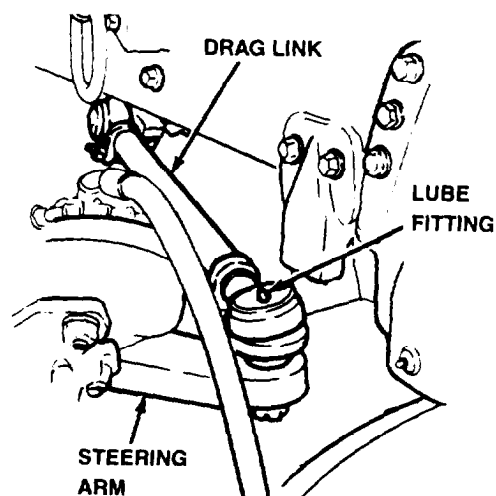
| Item No. | Interval | Item To B Inspected | Procedure | Not Mission Capable If: |
|----------|-------------|--------------------------------|---|--|
| 18 | Semi-Annual | Steering Assembly Continued | d. Lubricate rod ends with GAA. e. Lubricate the steering linkage U-joints and shafts with GAA. NOTE Lubricate every 1500 miles or semi-annually, whichever comes first. | d. Fittings will not purge old lubricant out of component. e. Fittings will not purge old lubricant out of component. |
| | | | | |
| 19 | Semi-Annual | Main Steering Gear | a. Check steering gear mounting bolts for looseness and leaks. If loose, torque bolts to 130 lb-ft (176 N•m). b. Check steering column U-joint, steering knuckles, tie rods, drag links, pitman arms, intergear link and main and slave, steering gear for looseness, breaks, cracks, rust and serviceability. | a. Bolts loose and/or Class III leaks. b. Looseness, breaks, or cracks evident. |

Table 2-1. Unit Level Preventive Maintenance Checks and Services

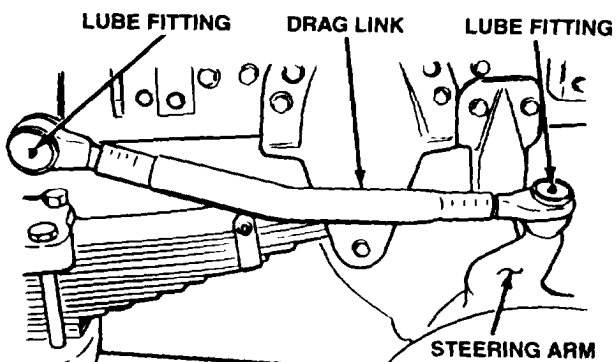
| Item No. | Interval | Item To Be Inspected | Procedure | Not Mission Capable If: |
|----------|-------------|-------------------------------------|---|---|
| 19 | Semi-Annual | Main Steering Gear Continued | <p>Check tie rod and drag links for proper torque. Tighten nuts to 165 to 180 lb-ft (224 to 244 N•m).</p> <p>d. Check tie rod adjustment. Measure left side tie rod to walking beam minimum clearance. Measure right side tie rod to walking beam minimum clearance. Minimum clearance between 2" to 2-1/8" indicates proper adjustment. If minimum clearance is not 2" to 2-1/8", readjust (paragraph 13-5).</p> <p>e. Check steering gear adjustment holes for dirt and rust. Clean holes and fill with grease.</p> | <p>c. Nuts will not torque to 165 to 180 lb-ft (224 to 244 N•m).</p> <p>d. Minimum clearance is not 2" to 2-1/8".</p> |



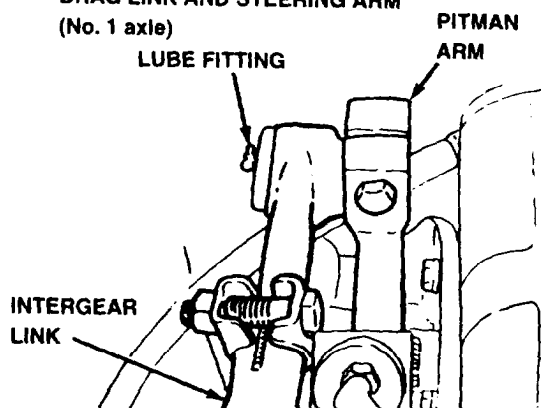
PITMAN ARM, MAIN STEERING GEAR



DRAG LINK AND STEERING ARM (No. 1 axle)



DRAG LINK AND STEERING ARM (No. 2 axle)



INTERGEAR LINK AND SLAVE STEERING GEAR PITMAN ARM (Left engine cover removed)

Table 2-1. Unit Level Preventive Maintenance Checks and Services

| Item No. | Interval | Item To Be Inspected | Procedure | Not Mission Capable If: |
|----------|-------------|--------------------------|--|---|
| 20 | Semi-Annual | Hydraulic Steering Lines | Follow routing of all hydraulic steering lines, hoses, and tubes to inspect for loose fitting, rubbing, chafing, cracks, bends, breaks, and leaks. Tighten if loose and replace or repair hoses or lines that are damaged (paragraph 13-6). | Class III leaks evident. |
| 21 | Semi-Annual | Power Steering Pump | Inspect power steering pump for leaks, cracks, and damage. | Cracks, damage, or Class III leaks. |
| 22 | Semi-Annual | Springs and Shocks | <p style="text-align: center;"><u>WARNING</u></p> <p>Do not start engine or move vehicle when anyone is under vehicle. Severe injury or death could result.</p> <p>Check spring leaves for cracks and breaks.</p> <p>b. Check spring clips, saddles, saddle caps, spring hangers for presence, looseness, cracks, and visible damage.</p> <p>c. Check for missing or broken retaining hardware, bolts or parts of suspension system.</p> <p>c.1. Check rubber bushings in the equalizer beams for deterioration and wear.</p> | <p>a. Cracks or breaks evident.</p> <p>b. Missing, loose, cracks, or visible damage evident.</p> <p>c. Any retaining hardware, bolts or parts are missing or broken.</p> <p>c. 1. Deterioration or wear is present.</p> |

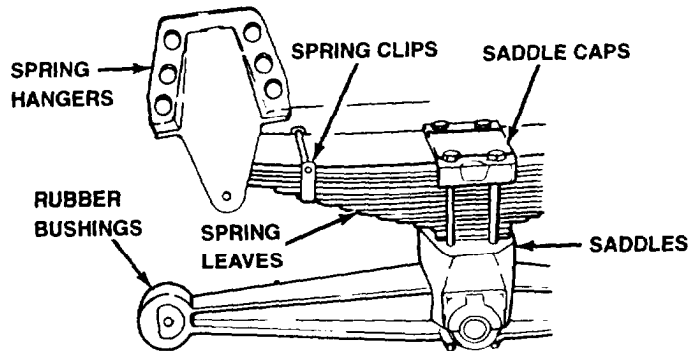


Table 2-1. Unit Level Preventive Maintenance Checks and Services

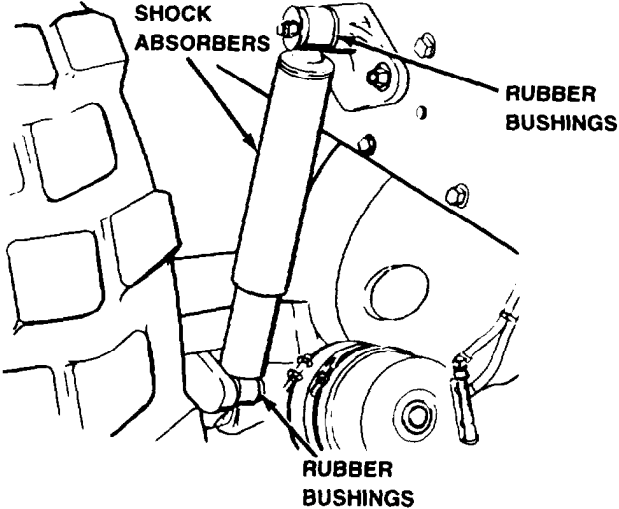
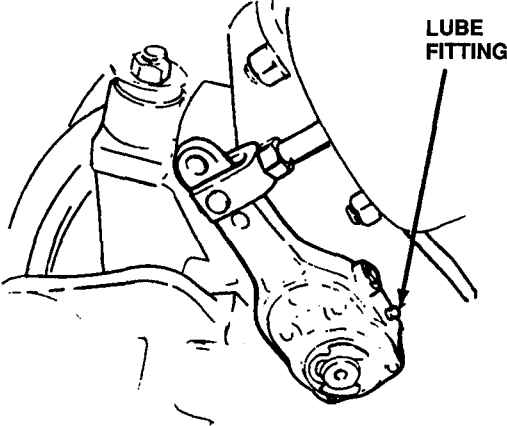
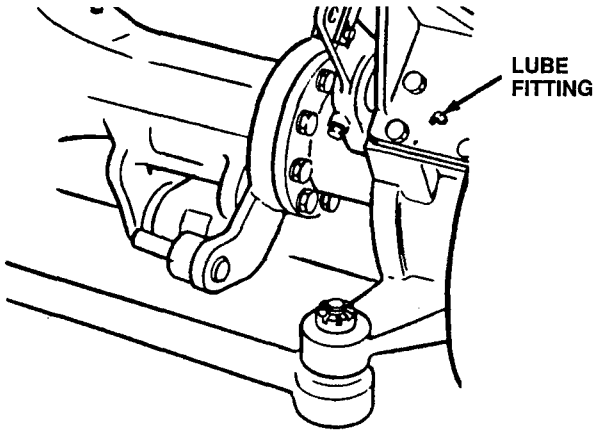
| Item No. | Interval | Item to Be Inspected | Procedure | Not Mission Capable If: |
|----------|-------------|-------------------------------------|--|--|
| 22 | Semi-Annual | Springs and Shocks Continued | <p>d. Check all shock absorbers. Look for oil leaks and damage.</p> <p>e. Check rubber bushings in the shock absorbers for cracks, damage and looseness.</p>  | <p>d. Class III oil leaks or damage is present.</p> <p>e. Rubber bushings are cracked, damaged or loose.</p> |
| 23 | Semi-Annual | Brake System | <p>a. Check slack adjuster linkage for damage and adjustment (paragraph 11-7).</p> <p>b. Check that brake shoe linings are not worn to less than 1/4 inch.</p> <p>c. Check brake drums for obvious grooves and uneven wear.</p> | <p>a. Adjustment is necessary or damage is evident.</p> <p>b. Brake shoe linings worn to less than 1/4 inch.</p> <p>c. Deep grooves or uneven wear is evident.</p> |

Table 2-1. Unit Level Preventive Maintenance Checks and Services

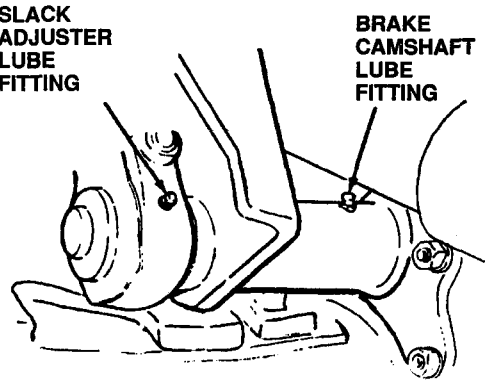
| Item No. | Interval | Item To Be Inspected | Procedure | Not Mission Capable If: |
|----------|-------------|---|--|--|
| 24 | Semi-Annual | No. 1 - 4 Axle Brake Cam-Shaft and Slack Adjuster | <p style="text-align: center;">NOTE</p> <p>When using a grease gun, apply lubricant to the fitting until clean lubricant squeezes out of the part being lubricated.</p> <p>Lubricate the No. 1 - 4 axle brake camshafts and slack adjusters with GAA.</p> | Fitting will not purge old lubricant out of component. |



NO. 1 AXLE SLACK ADJUSTER AND BRAKE CAMSHAFT



NO. 2 AXLE SLACK ADJUSTER AND BRAKE CAMSHAFT



NO. 3 AND 4 AXLE BRAKE CAMSHAFT AND SLACK ADJUSTER

Table 2-1. Unit Level Preventive Maintenance Checks And Services

| Item No. | Interval | Item To Be Inspected | Procedure | Not Mission Capable If: |
|----------|-------------|---------------------------------------|--|--|
| 25 | Semi-Annual | Frame and Crossmembers | <p>a. Inspect frame side rails for cracks, breaks, bends, wear deterioration and missing and loose fasteners.</p> <p>b. Inspect crossmembers for cracks, breaks, bends, wear deterioration and missing and loose fasteners.</p> | <p>a. Cracks, bends, or breaks in frame. Any loose or missing fasteners.</p> <p>b. Cracks, bends, or breaks in crossmembers. Any loose or missing fasteners.</p> |
| 26 | Semi-Annual | Torque Rods | <p>a. Check seven torque rods for damage.</p> <p>b. Check mounting brackets for cracks, breaks, rust, and loose mounting hardware on frame.</p> | <p>a. Damage is evident.</p> <p>b. Cracks, breaks, or loose mounting hardware.</p> |
| 27 | Semi-Annual | Propeller Shafts and Universal Joints | <p style="text-align: center;"><u>WARNING</u></p> <p>Do not start engine or move vehicle when anyone is under vehicle. Severe injury or death could result.</p> <p style="text-align: center;">NOTE</p> <p>When using a grease gun, apply lubricant to the fitting until clean lubricant squeezes out of the part being lubricated.</p> <p style="text-align: center;">NOTE</p> <p>Use the proper lubricant to purge all four bearing seals of each universal joint. This flushes abrasive contaminants from each bearing and assures all four bearings are filled properly. Pop the seals. These seals are made to be popped.</p> <p>If any seals fail to purge, move propeller shaft from side-to-side while applying gun pressure. This allows greater clearance on thrust end of bearing that is not purging. If seals still do not purge, rock vehicle by releasing the parking brakes, start engine, put transmission in D or R, and allow vehicle to roll.</p> | |

Table 2-1. Unit Level Preventive Maintenance Checks And Services

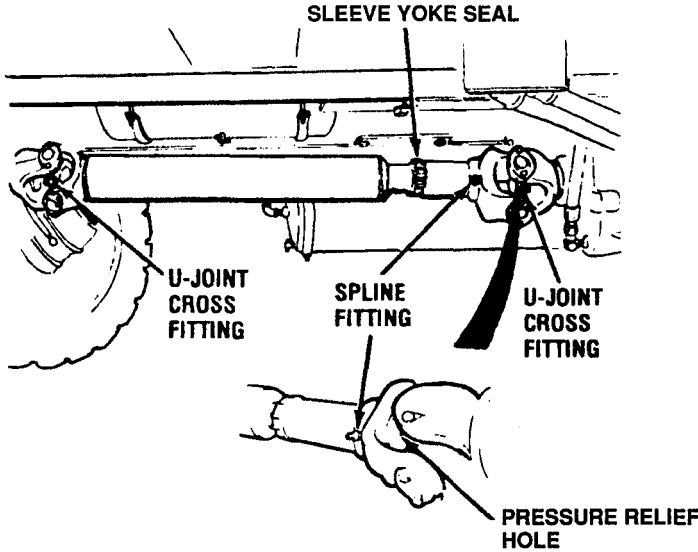
| Item No. | Interval | Item To Be Inspected | Procedure | Not Mission Capable If: |
|--|-------------|--|--|--|
| 27 | Semi-Annual | Propeller Shafts and Universal Joints Continued | <p>When lubricating spline end of propeller shafts, apply grease to spline fitting until lubricant appears at pressure relief hole. Cover hole with finger and continue adding grease until it appears at sleeve yoke seal.</p> <p style="text-align: center;">NOTE</p> <p>When vehicle is operating under severe conditions, lubricate propeller shafts and universal joints every 50 hours.</p> <p>a. Lubricate all axle propeller shafts and universal joints, three fittings per axle, with GAA.</p> <p>b. Lubricate transmission to transfer case propeller shaft and universal joints with GAA.</p> | <p>a. Fitting will not purge old lubricant out of component.</p> <p>b. Fitting will not purge old lubricant out of component.</p> |
|  | | | <p>c. Inspect all propeller shafts for bends and cracks.</p> <p>d. Inspect U-joints for wear, play, broken or missing lubrication fittings. There should be no free play at U-joint.</p> | <p>c. Bends or cracks evident.</p> <p>d. Lubrication fittings, screws or lock tabs are broken or missing. Wear and play evident.</p> |

Table 2-1. Unit Level Preventive Maintenance Checks and Services

| Item No. | Interval | Item To Be Inspected | Procedure | Not Mission Capable If: |
|----------|-------------|----------------------|--|--|
| 28 | Semi-Annual | Engine Crank-case | <p style="text-align: center;">NOTE</p> <p style="text-align: center;">COLD TEMPERATURE OPERATION</p> <p>For operation of equipment in expected continuous temperatures below 0° F (-18° C), remove lubricants prescribed in the key for temperature above 0° F (-18° C). Relubricate with lubricant specified in the key for temperatures 0° F to -50° F (-18° C to -46° C).</p> <p style="text-align: center;">NOTE</p> <p>To perform PMCS checks on right side of engine, spare tire must be removed (TM 9-2320-279-10). Open engine cover (TM 9-2320-279-10).</p> <p style="text-align: center;">NOTE</p> <p>After installing new filter element, fill crankcase, operate engine 5 minutes, and check housing for leaks. Shut down engine, check crankcase oil level and bring to full mark.</p> <p style="text-align: center;">NOTE</p> <p>Oil and oil filter will be changed only when they are known to be contaminated, clogged, or when service is recommended by AOAP laboratory.</p> <p style="text-align: center;">NOTE</p> <p>If AOAP laboratory support is not available, change oil and oil filter at 6,000 miles (9,654 km) or every six months.</p> <p>a. Drain and refill crankcase with OE/HDO.</p> <p>b. Replace engine oil filter.</p> <p style="text-align: center;">NOTE</p> <p>Small particles are common; however, large metal particles indicate possible damage.</p> | <p>Faulty oil results received from AOAP lab. "Do not operate".</p> <p>b. Oil filter has Class III leak.</p> |

Table 2-1. Unit Level Preventive Maintenance Checks And Services

| Item No. | Interval | Item To Be Inspected | Procedure | Not Mission Capable If: |
|----------|-------------|------------------------------------|--|---|
| 28 | Semi-Annual | Engine Crank-case Continued | c. Check all oil lines and hoses for cracks and wear that could cause leaks. d. Check oil filter housing and oil pan drain plug for looseness. Make sure all oil pan bolts are tight. e. Check rocker housing covers for evidence of leaks. f. Check all engine compartment wiring for frays, splits, missing insulation or poor connections. Replace any worn wiring. g. Inspect alternator mounting for looseness. Inspect bracket and attaching hardware for cracks, bends, and loose mounting. | c. Cracks, frays, leaks, and wear are evident. d. Drain plugs and oil pan bolts are loose. e. Class III leaks evident. f. Insulation missing. Frays, splits, poor connections evident. g. Loose mounting, cracks, or bends evident. |
| 29 | Semi-Annual | Battery Electrical System | <p style="text-align: center;">NOTE</p> Refer to TM 9-6140-200-14 for more specific details on battery maintenance. a. Inspect battery box for corrosion and debris. b. Clean slave receptacle terminals and coat with corrosion preventive compound. c. Check and record specific gravity of each cell. d. Inspect battery cables for frays, splits, and looseness. | a. Corrosion has made holes in metal battery box. b. Terminals corroded. c. If cell is below 1.225 specific gravity. d. Cables frayed, split, or loose. |

Table 2-1. Unit Level Preventive Maintenance Checks and Services

| Item No. | Interval | Item To Be Inspected | Procedure | Not Mission Capable If: |
|----------|----------|----------------------|---|-------------------------|
| | | | <p style="text-align: center;">FINAL ROAD TEST</p> <p>After all services and inspections have been completed, take vehicle on a short road test to make sure all corrections have been accomplished. Correct any defects or malfunctions that occur during this test.</p> <p>During road test:</p> <ol style="list-style-type: none"> 1. Listen for any noises. 2. Check steering operation. 3. Check operation of brakes. 4. Check transmission operation - all ranges. 5. Check engine retarder (JACOBS ENGINE BRAKE) operation (TM 9-2320-279-10). 6. Note any loss of power or rough running engine. 7. Check driveline lockup system operation (TM 9-2320-279-10). | |

Table 2-1. Unit Level Preventive Maintenance Checks And Services

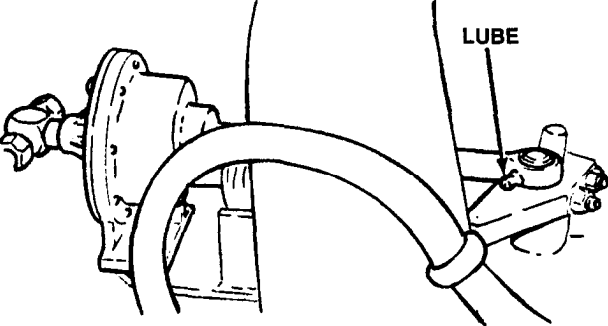
| Item No. | Interval | Item To Be Inspected | Procedure | Not Mission Capable If: |
|----------|------------------------|-----------------------|--|--|
| 30 | Annual | Engine Throttle Lever | Lubricate the engine throttle lever pivot with GAA.  | Fitting will not purge old lubricant out of component. |
| 31 | Annual | Headlights | Check headlight adjustment. Adjust headlights (paragraph 7-57). | |
| 32 | Annual or On Condition | Hydraulic System | <p style="text-align: center;">NOTE</p> Hydraulic fluid and filters will be changed only when they are known to be contaminated, clogged, or when service is recommended by AOAP laboratory. <p style="text-align: center;">NOTE</p> If AOAP laboratory is not available, change oil and oil filter at 6,000 miles (9,654 km) or every six months. a. Replace hydraulic fluid filters (all models paragraph 13-8, except M984A1, paragraph 13-13). <p style="text-align: center;">NOTE</p> To drain hydraulic reservoir, remove bottom drain plug. | Faulty oil results received from AOAP lab. "Do not operate". |

Table 2-1. Unit Level Preventive Maintenance Checks and Services

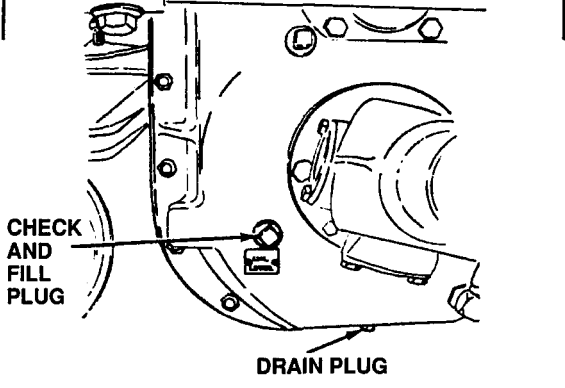
| Item No. | Interval | Item To Be Inspected | Procedure | Not Mission Capable If: |
|--|----------|-----------------------------------|---|-------------------------------------|
| 32 | Annual | Hydraulic System Continued | b. Drain reservoir using drain plug. c. Refill hydraulic reservoir using OE/HDO. | b. AOAP indicates changes required. |
| 33 | Annual | Tires | <p style="text-align: center;">NOTE</p> Tires should only be rotated on the same side within same tandem. Rotate tires. Switch tires on No. 1 and No. 2 axles on right side. Switch tires on No. 3 and No. 4 axles on right side. Switch tires on No. 1 and No. 2 axles on left side. Switch tires on No. 3 and No. 4 axles on left side. | |
| 34 | Annual | Transfer Case | Drain oil from transfer case at drain plug. Refill with OE/HDO at fill plug. | |
|  | | | | |
| 35 | Annual | Rear Axles | <p style="text-align: center;">NOTE</p> Do not remove wheels from hubs. Use truck wheel lift to remove wheels and hub as an assembly. <p style="text-align: center;">NOTE</p> Adjust slack adjuster after servicing wheel bearing (paragraph 11-6). | |

Table 2-1. Unit Level Preventive Maintenance Checks And Services

| Item No. | Interval | Item To Be Inspected | Procedure | Not Mission Capable If: |
|----------|----------|-----------------------------|---|--|
| 35 | Annual | Rear Axles Continued | <p>a. Inspect each input and output shaft seal for damage and leaks.</p> <p>b. Remove, clean, and check wheel bearings for damage or wear (paragraph 12-3).</p> <p>c. Clean hub and brake shoe assemblies with brake cleaning solvent.</p> <p style="text-align: center;">NOTE</p> <p>If hub has one gouge or groove, turn hub into Direct Support for resurfacing.</p> <p>d. Check brake drums for obvious grooves and uneven wear.</p> | <p>a. Class III leaks.</p> <p>b. Wheel bearings loose, damaged, or worn.</p> <p>d. Deep grooves or uneven wear is evident.</p> |
| 36 | Annual | Front Wheel Bearings | <p style="text-align: center;">NOTE</p> <p>Do not remove wheels from hubs. Use truck wheel lift to remove wheels and hub as an assembly.</p> <p style="text-align: center;">NOTE</p> <p>Adjust slack adjuster after servicing wheel bearing (paragraph 11-6).</p> <p style="text-align: center;">NOTE</p> <p>See paragraph 12-2 for bearing removal and installation.</p> <p>a. Remove, clean and re-pack the front wheel bearings with GAA.</p> <p>b. Check wheel bearings for looseness, damage or wear (paragraph 12-2).</p> <p>c. Clean hub and brake shoe assemblies with brake cleaning solvent.</p> | <p>a. Lubrication is not present or is dirty.</p> <p>b. Loose, damaged or wear evident.</p> |

Table 2-1. Unit Level Preventive Maintenance Checks and Services

| Item No. | Interval | Item To Be Inspected | Procedure | Not Mission Capable If: |
|----------|----------|---------------------------------------|--|--|
| 36 | Annual | Front Wheel Bearings Continued | <p style="text-align: center;">NOTE</p> <p>If hub has one gouge or grooves, turn hub into Direct Support for resurfacing.</p> <p>d. Check brake drums for obvious grooves and uneven wear.</p> | d. Deep grooves or uneven wear is evident. |
| 37 | Annual | Fuel Systems | Replace secondary fuel filter element. | |
| 38 | Annual | Compressed Air System | <p style="text-align: center;">NOTE</p> <p>In areas where more than approximately 30 degree range of temperature is common, small amounts of water can accumulate in the air brake system due to condensation. The presence of small amounts of water due to condensation is normal.</p> <p>a. Check air compressor and air governor for mounting looseness and leaks.</p> <p>b. Check air governor operation and adjust as required.</p> <p>c. Start engine (see TM 9-2320-279-10).</p> <p>d. Watch air pressure gage. Needle should move up scale as system pressure builds up.</p> <p>e. After several minutes, gage needle should stop between 120 and 125 psi (827 and 862 kPa) as governor cuts out. When governor cuts out, released air from air dryer can be heard. If governor does not cut out between 120 and 125 psi (827 and 862 kPa), adjust governor.</p> | <p>a. Looseness or leaks evident.</p> <p>b. Governor will not adjust.</p> <p>c. Engine will not start.</p> <p>d. Needle does not move.</p> <p>e. Air pressure not below 120 and 125 psi or governor will not adjust.</p> |

Table 2-1. Unit Level Preventive Maintenance Checks And Services

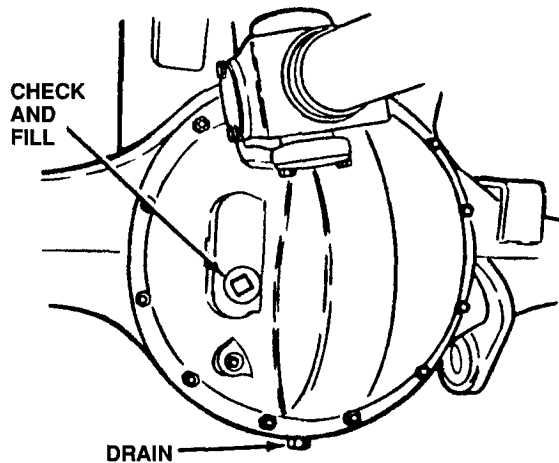
| Item No. | Interval | Item To Be Inspected | Procedure | Not Mission Capable If: |
|----------|----------|---|---|-------------------------|
| 38 | Annual | Com-pressed Air System Continued | <p style="text-align: center;"><u>WARNING</u></p> <p>Muffler and connecting parts may be hot. Do not touch or lean against muffler. Serious burns could result.</p> <p>ADJUSTMENT</p> <ol style="list-style-type: none"> 1. Loosen locknut on bottom of governor. Turn adjusting screw in to decrease cutout pressure or out to increase cut out pressure. 2. Hold adjusting screw and tighten locknut 80 to 120 lb-in (9.4 to 13.5 N·m). 3. Depress and release brake pedal enough times to reduce air pressure reading on gage to below 100 psi (690 kPa). 4. Start engine. Note pressure at which governor cuts out. If further adjustment is needed, go back to step 1. | |

Table 2-1. Unit Level Preventive Maintenance Checks and Services

| Item No. | Interval | Item To Be Inspected | Procedure | Not Mission Capable If: |
|----------|----------|----------------------|--|-------------------------|
| | | | <p style="text-align: center;">FINAL ROAD TEST</p> <p>After all services and inspections have been completed, take vehicle on a short road test to make sure all corrections have been accomplished. Correct any defects or malfunctions that occur during this test.</p> <p>During road test:</p> <ol style="list-style-type: none"> 1. Listen for any noises. 2. Check steering operation. 3. Check operation of brakes. 4. Check transmission operation; all ranges. 5. Check engine retarder (JACOBS ENGINE BRAKE) operation (TM 9-2320-279-10). 6. Note any loss of power or rough running engine. 7. Check driveline lockup system operation (TM 9-2320-279-10). | |

Table 2-1. Unit Level Preventive Maintenance Checks And Services

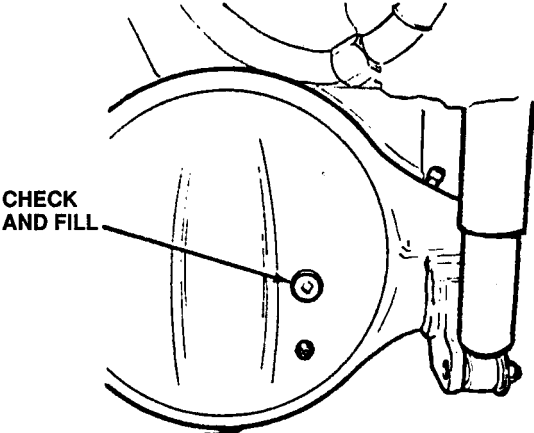
| Item No. | Interval | Item To Be Inspected | Procedure | Not Mission Capable If: |
|----------|------------|----------------------|---|---|
| 39 | Biennially | Rear Axles | <p style="text-align: center;">NOTE</p> <p>Change lubricant in new or rebuilt axles within 1,000 miles (1,600 km) but no sooner than 500 miles (800 km). Following initial drain, change lubricant every 12,000 miles (19,308 km) or 2 years of service, whichever comes first. During all lubricant changes, remove metal particles from magnetic drain and filler plugs.</p> <p style="text-align: center;">NOTE</p> <p>During lubricant changes on the No. 2 and No. 3 axles, clean the lube pump filter screen. To completely drain No. 2 and No. 3 axles, remove plug at bottom of power divider in addition to drain plug in bottom of differential housing.</p> <p style="text-align: center;">NOTE</p> <p>When filling No. 3 and No. 4 differentials, fill to bottom of CHECK and FILL hole, then raise one end of axle 8 in. (203 mm) to allow lubricant to flow out to wheel bearing. Lower the axle and refill. Raise other end of axle the same way, then lower and refill again.</p> <p style="text-align: center;">NOTE</p> <p>When refilling No. 2 and No. 3 differentials, add 1 quart (0.94 L) of lubricant through fill hole in top of power divider.</p> <p>a. Drain and refill No. 3 axle differential with GO.</p> | <p>a. No. 3 axle differential has not been drained within specified interval.</p> |



NO. 2 AND 3 AXLE DIFFERENTIALS

Table 2-1. Unit Level Preventive Maintenance Checks and Services

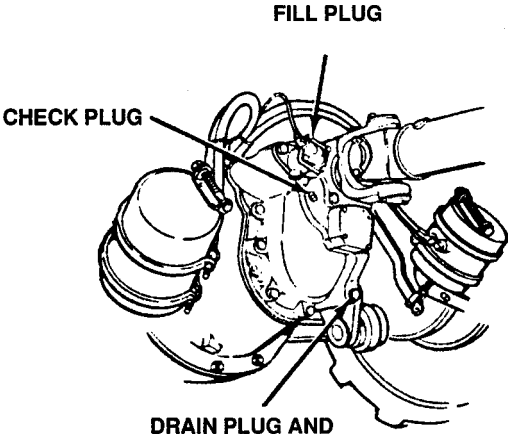
| Item No. | Interval | Item To Be Inspected | Procedure | Not Mission Capable If: |
|----------|------------|----------------------|--|--|
| 39 | Biennially | Rear Axles Continued | <p>b. Drain and refill No. 3 axle power divider with GO.</p> <p>c. Drain and refill No. 4 axle differential with GO.</p> | <p>b. No. 3 axle power divider has not been drained within specified interval.</p> <p>c. No. 4 axle differential has not been drained with specified interval.</p> |



CHECK AND FILL

DRAIN

NO. 1 AND 4 AXLE DIFFERENTIALS



FILL PLUG

CHECK PLUG

DRAIN PLUG AND FILTER SCREEN

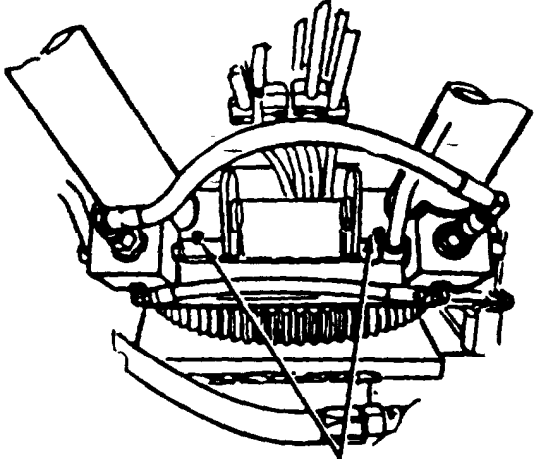
POWER DIVIDER, NO. 2 AND 3 AXLES

Table 2-1. Unit Level Preventive Maintenance Checks And Services

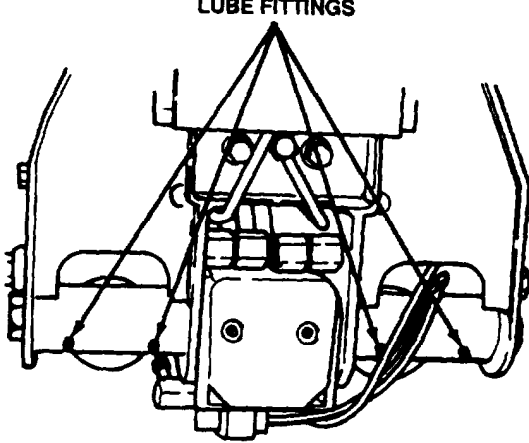
| Item No. | Interval | Item To Be Inspected | Procedure | Not Mission Capable If: |
|----------|------------|----------------------|--|-------------------------|
| 40 | Biennially | Front Axles | <p style="text-align: center;">NOTE</p> <p>Change lubricant in new or rebuilt axles within 1,000 miles (1,600 km) but no sooner than 500 miles (800 km). Following initial drain, change lubricant every 12,000 miles (19,308 km) or 2 years of service, whichever comes first. During all lubricant changes, remove metal particles from magnetic drain and filler plugs.</p> <p style="text-align: center;">NOTE</p> <p>During lubricant changes on No. 2 axles, clean the lube pump filter screen. To completely drain No. 2 axles, remove the plug at bottom of power divider in addition to drain plug in bottom of differential housing.</p> <p style="text-align: center;">NOTE</p> <p>Fill No. 1 and No. 2 differential housings to a level even with bottom of check and fill plug hole.</p> <p style="text-align: center;">NOTE</p> <p>When refilling No. 2 differential, add 1 quart (0.94 L) of lubricant through fill hole in top of power divider.</p> <p>a. Drain lubricant from No. 1 and No. 2 axle differential and refill with GO.</p> <p>b. Drain No. 2 axle power divider at drain plug. Refill with GO at fill plug.</p> | |

Table 2-2. Unit Level Preventive Maintenance Checks And Services

| Item No. | Interval | Item To Be Inspected | Procedure | Not Mission Capable If: |
|----------|-------------|---|---|---|
| 2 | Semi-Annual | M977 and M985 Crane Continued Erection Cylinder Pivot | Lubricate the upper and lower ends of erection cylinder with GAA. | Fittings will not purge old lubricant out of component. |



**LUBE FITTINGS
LOWER ERECTION CYLINDER PIVOT**



**LUBE FITTINGS
UPPER ERECTION CYLINDER PIVOT**

Table 2-2. Unit Level Preventive Maintenance Checks and Services

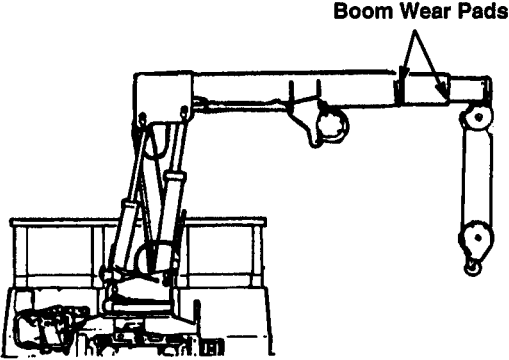
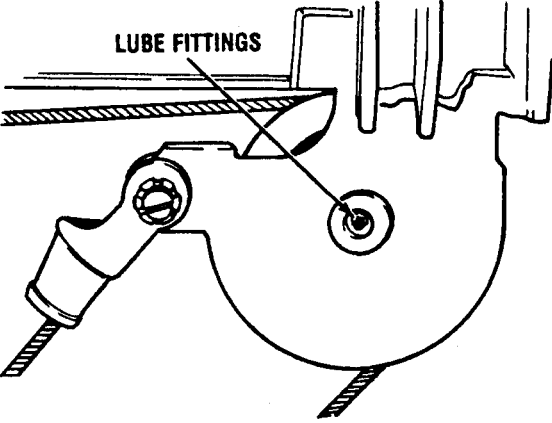
| Item No. | Interval | Item To Be Inspected | Procedure | Not Mission Capable If: |
|----------|-------------|--|--|--|
| 3 | Semi-Annual | M977 and M985 Crane Continued Boom Wear Pads | <p style="text-align: center;">NOTE</p> <p>Lubricate outrigger bottom plate, boom wear pads and exposed rotation gears more often when cranes are operated on sandy or dusty conditions.</p> <p>Clean sliding surfaces of boom wear pads and lubricate by coating with GAA.</p>  | |
| 4 | Semi-Annual | Boom Nose Sheave | <p>Lubricate boom nose sheave bushing with GAA.</p>  <p style="text-align: center;">M977 AND M985 HAVE ONE FITTING.</p> | <p>Fittings will not purge old lubricant out of component.</p> |

Table 2-2. Unit Level Preventive Maintenance Checks And Services

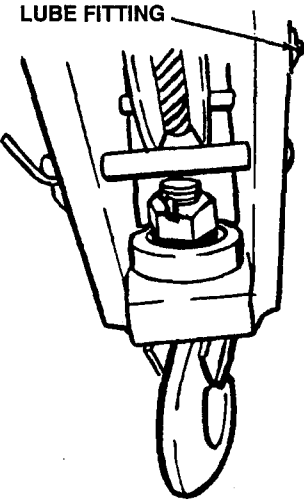
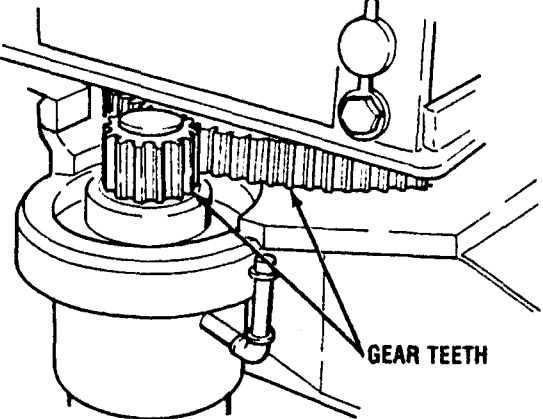
| Item No. | Interval | Item To Be Inspected | Procedure | Not Mission Capable If: |
|----------|-------------|---|---|---|
| 5 | Semi-Annual | M977 and M985 Crane Continued Hook Block Sheave | Lubricate hook block sheave bushing with GAA (M985).  | Fittings will not purge old lubricant out of component. |
| 6 | Semi-Annual | Rotation Gear and Pinion Teeth | <p>NOTE</p> Lubricate outrigger bottom plate, boom wear pads and exposed rotation gears more often when cranes are operated on sandy or dusty conditions. <p>NOTE</p> Lubricate after high pressure wash. Coat external teeth of rotation gear lightly with GAA grease.  | Lube contaminated. |

Table 2-2. Unit Level Preventive Maintenance Checks and Services

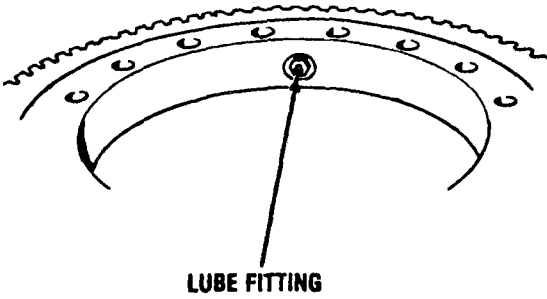
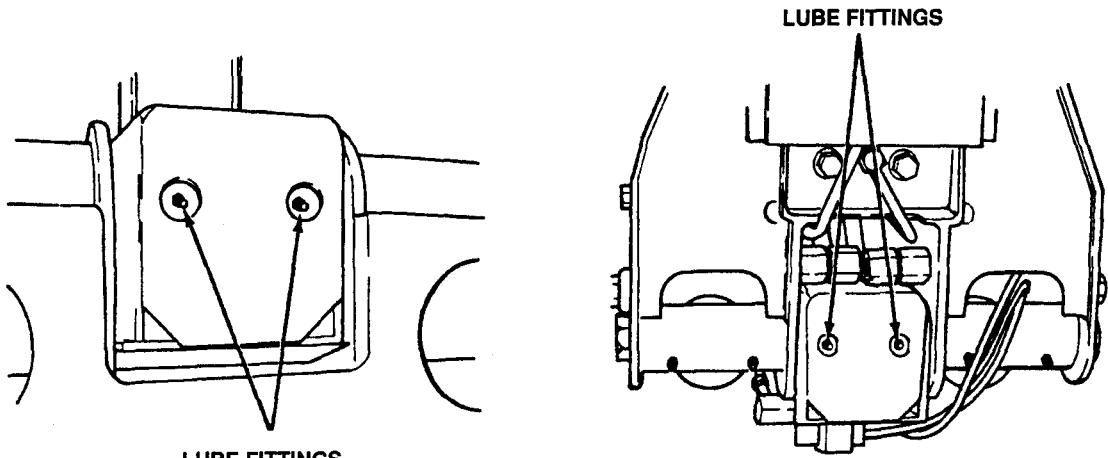
| Item No. | Interval | Item To Be Inspected | Procedure | Not Mission Capable If: |
|----------|-------------|---|---|---|
| 7 | Semi-Annual | M977 and M985 Crane Continued Turntable Bearing | <p>Raise mast until lube fitting comes into view. Turn and lubricate with GAA. Turn table every 90 degrees until you have turned the turntable 360 degrees. Then rotate the crane a full 360 degrees to spread the lubricant.</p>  <p style="text-align: center;">LUBE FITTING</p> | Fittings will not purge old lubricant out of component. |
| 8 | Semi-Annual | Mast Pivot | <p>Lubricate both ends of mast with GAA.</p>  <p style="text-align: center;">LUBE FITTINGS</p> <p style="text-align: center;">LOWER MAST PIVOT</p> <p style="text-align: center;">UPPER MAST PIVOT</p> | Fittings will not purge old lubricant out of component. |

Table 2-2. Unit Level Preventive Maintenance Checks And Services

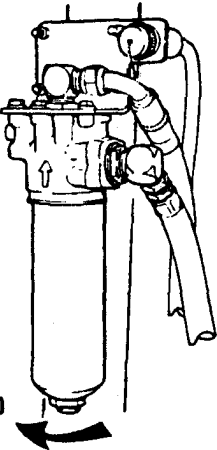
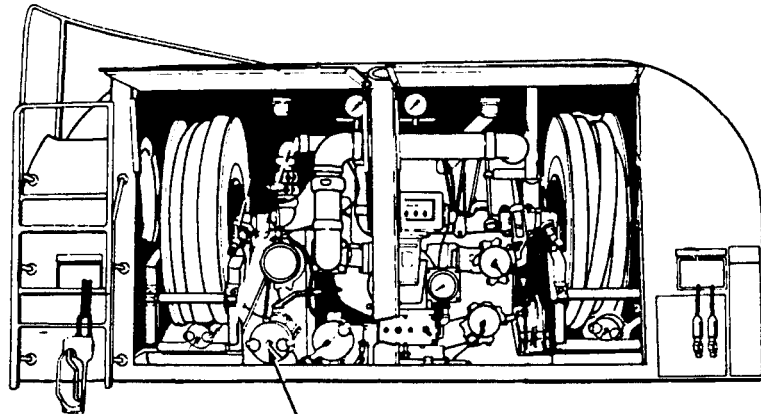
| Item No. | Interval | Item To Be Inspected | Procedure | Not Mission Capable If: |
|----------|-------------|--|--|--|
| 9 | Semi-Annual | M977 and M985 Crane Continued Outrigger Bottom Plate | <p style="text-align: center;">NOTE</p> <p>Lubricate outrigger bottom plate, boom wear pads and exposed rotation gears more often when cranes are operated on sandy or dusty conditions.</p> <p>Clean sliding surfaces of outrigger bottom plate and lubricate with grease (GAA).</p> | |
| 10 | Semi-Annual | Hydraulic Fluid Filter | <p style="text-align: center;">NOTE</p> <p>Hydraulic fluid and filters will change only when they are known to be contaminated, clogged, or when service is recommended by AOAP laboratory.</p> <p>Replace crane hydraulic fluid filter (paragraph 19-17).</p> <div style="text-align: center;">  <p>TURN TO REMOVE</p> </div> <p style="text-align: center;">HYDRAULIC FLUID FILTER</p> | Faulty oil results received from AOAP lab. "Do not operate". |

Table 2-2. Unit Level Preventive Maintenance Checks and Services

| Item No. | Interval | Item To Be Inspected | Procedure | Not Mission Capable If: |
|----------|-------------|---|--|--|
| 11 | Semi-Annual | M977 and M985 Crane Continued Hoist Cable | a. Unreel, clean and oil cable with OE/HDO (M977, M984 and M984A1). b. Inspect hoist wire rope for kinks, broken strands and wear. | b. Evidence of kinks, frays or breaks. |
| 12 | Semi-Annual | M978 Fuel Service Module | <p style="text-align: center;">CAUTION</p> Do not lubricate "B" gravity receptacle. Fuel contamination and equipment damage may result. | |



"B" GRAVITY RECEPTACLE

Table 2-2. Unit Level Preventive Maintenance Checks And Services

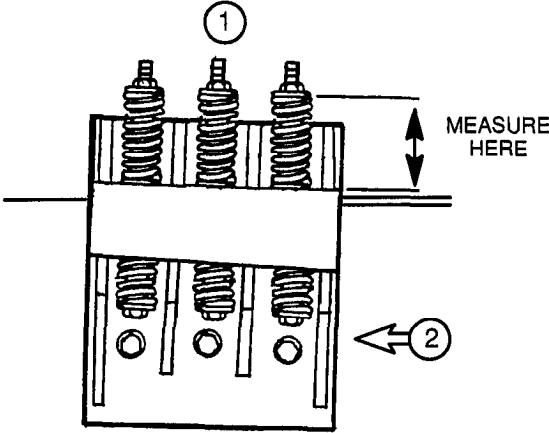
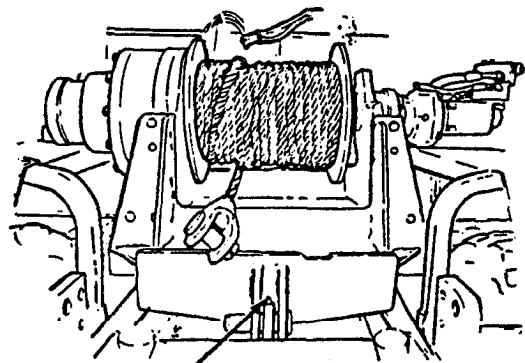
| Item No. | Interval | Item To Be Inspected | Procedure | Not Mission Capable If: |
|----------|-------------|---------------------------------|---|---|
| 13 | Semi-Annual | M978 Tank Front Mounting Screws | <p>NOTE</p> <p>In order to check springs on the left side of truck, use a long thin bar to reach the bottom of the bolt and tap them upward. This is necessary because of fuel tank position.</p> <p>NOTE</p> <p>Before checking measurement at Point 1, take a hammer and tap the bolts upward at Point 2. This will make certain the bolts and springs are seated properly.</p> <p>a. Check spring height on front mounting screws. Spring height should be 3-1/2 inches to 3-3/4 inches (89 mm to 95 mm).</p> <p>b. If top spring is 3-1/2 inches (89 mm), and there is free play in bolt, remove bolt and measure bottom spring.</p> <p>c. If both springs are greater than 3-1/2 inches (89 mm), check that rubber mount is 1 inch (25 mm) thick.</p>  | <p>a. Spring height is not between 3-1/2 inches to 3-3/4 inches (89 mm to 95 mm).</p> <p>b. Bottom spring is shorter than 3-1/2 inches (89 mm).</p> <p>c. Rubber mount is less than 3/4 inches (19 mm).</p> |
| 14 | Semi-Annual | Tank Rear Mounting Screws | <p>CAUTION</p> <p>Spacer sleeves on rear screws must not be modified. Damage to equipment could result.</p> <p>Bolts may not turn, but be properly torqued.</p> <p>Check torque on rear mounting screws 110 lb-ft (149 N·m).</p> | <p>Screws will not torque.</p> |

Table 2-2. Unit Level Preventive Maintenance Checks and Services

| Item No. | Interval | Item To Be Inspected | Procedure | Not Mission Capable If: |
|----------|-------------|--|--|--|
| 15 | Semi-Annual | M978 Continued Tanker Line Strainer and Filter Separator | <p style="text-align: center;">NOTE</p> <p>To complete this service, the tank must be drained. After service is completed, prepare tanker for operation and recirculate fuel (TM 9-2320-279-10).</p> <p style="text-align: center;">NOTE</p> <p>The filter separator must be drained (TM 9-2320-279-10) and the VT Venturi assembly removed (paragraph 25-36) to perform the following service. After service is completed, reinstall VT Venturi assembly (paragraph 25-36) and recirculate fuel (TM 9-2320-279-10).</p> <p>a. Check and clean fuel strainer. Look for pieces of string or rubber that may indicate damage or deteriorating hoses.</p> <p>b. Check fuel line strainer assembly for leaks.</p> <p>c. Change filter-separator elements.</p> <p>d. Check filter-separator for fuel leaks.</p> | <p>a. Damage or deteriorating hoses.</p> <p>b. Fuel leak evident.</p> <p>c. Filter-separator element has not been replaced in specified interval.</p> <p>d. Fuel leak evident.</p> |

Table 2-2. Unit Level Preventive Maintenance Checks And Services

| Item No. | Interval | Item To Be Inspected | Procedure | Not Mission Capable If: |
|----------|-------------|---|--|---|
| 16 | Semi-Annual | M984 Heavy Duty Recovery Winch Drum Gear Box | <p style="text-align: center;">NOTE</p> <p style="text-align: center;">COLD TEMPERATURE OPERATION</p> <p>For operation of equipment in expected continuous temperatures below 0 degree F (-18 degree C), remove lubricants prescribed in key for temperatures above 0 degree F (-18 degree C). Relubricate with lubricants specified in the key for temperatures 0 degree F to -50 degree F (-18 degree C to -46 degree C). After changing to OEA, drain one pint of oil from oil sampling valve.</p> <p style="text-align: center;">NOTE</p> <p>Change oil in winch gear box after the first ten hours of winch operation.</p> <p>Check oil level of the drum gearbox and fill as required with GO.</p> | |
| 17 | Semi-Annual | Rear Attachment Fitting | Lubricate the rear attachment with GAA. | Fittings will not purge old lubricant out of component. |



Rear Attachment Fitting

Table 2-2. Unit Level Preventive Maintenance Checks and Services M977 - M985

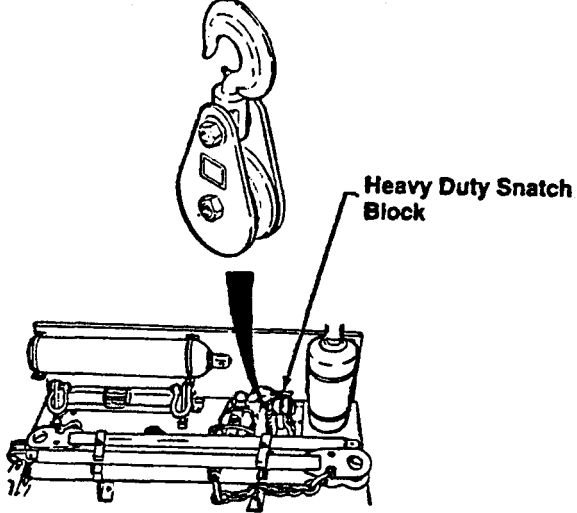
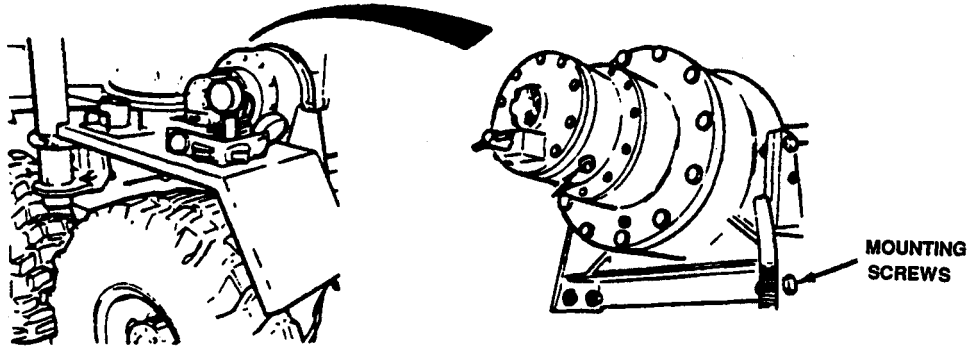
| Item No. | Interval | Item To Be Inspected | Procedure | Not Mission Capable If: |
|----------|-------------|---|---|--|
| 18 | Semi-Annual | M984 Heavy Duty Recovery Winch Heavy Duty Snatch Block | <p>Lubricate center shaft after each use with GAA.</p>  <p>The diagram shows a heavy duty snatch block being lowered into the center of a winch mechanism. A label 'Heavy Duty Snatch Block' points to the block. Below the diagram, step 'a' describes tightening mounting screws to 260 lb-ft (339 N-m).</p> <p>a. Tighten winch mounting screws to 260 lb-ft (339 N-m).</p> | <p>a. Screws not torqued to 260 lb-ft (339 N-m).</p>  <p>The diagram shows a winch mounted on a vehicle chassis. Arrows point to the mounting screws on the chassis. A label 'MOUNTING SCREWS' points to one of the screws. Below the diagram, steps 'b' and 'c' describe checking the cable and engine governor.</p> <p>b. Unwind winch cable completely and check for kinks, broken strands, and wear.</p> <p>c. While operating winch, check that engine governor maintains 1,500 + or - 25 rpm or engine surges erratically.</p> |

Table 2-2. Unit Level Preventive Maintenance Checks And Services M977 - M985

| Item No. | Interval | Item To Be Inspected | Procedure | Not Mission Capable If: |
|----------|-------------|--|---|---|
| 19 | Semi-Annual | M984 Heavy Duty Recovery Winch Winch Breather | <p style="text-align: center;"><u>WARNING</u></p> <p>Adhesives, solvents, and sealing compounds can burn easily, can give off harmful vapors, and are harmful to skin and clothing. To avoid injury or death, keep away from fire and use in well-ventilated area. If adhesive, solvents, or sealing compound get on skin or clothing, wash immediately with soap and water.</p> <p>a. Remove breather from winch.</p> <p>b. Clean breather with dry cleaning solvent and brush.</p> <p>c. Apply pipe thread sealing compound to threads of breather and install in winch.</p> | Breather missing or cannot be cleaned. |
| 20 | Semi-Annual | Winch Brakes | Apply front axle parking brake and check that slack adjusters on front axle move. | Slack adjusters on front axle do not move. |
| 21 | Semi-Annual | M983 Fifth Wheel Jaws | Tighten fifth wheel mounting screws to 170 lb-ft (231 N·m). | Screw will not torque to 170 lb-ft (231 N·m). |

Table 2-2. Unit Level Preventive Maintenance Checks and Services

| Item No. | Interval | Item To Be Inspected | Procedure | Not Mission Capable If: |
|----------|-------------|--|--|--|
| 22 | Semi-Annual | M984A1 Heavy Duty Recovery Winch Winch Mounts | <p style="text-align: center;">NOTE</p> <p>Heavy-duty winch is lubricated by the hydraulic oil and needs no further lubrication.</p> <p style="text-align: center;">NOTE</p> <p>Purging of lubricant.</p> <p>When using a grease gun, apply lubricant to the fitting until clean lubricant squeezes out of the part being lubricated.</p> <p>Lubricate winch mount fittings with GAA.</p> <p style="text-align: center;">NOTE</p> <p>Lubricate every 1500 miles or semiannually, whichever comes first.</p> | <p>Fittings will not purge old lubricant out of component.</p> |

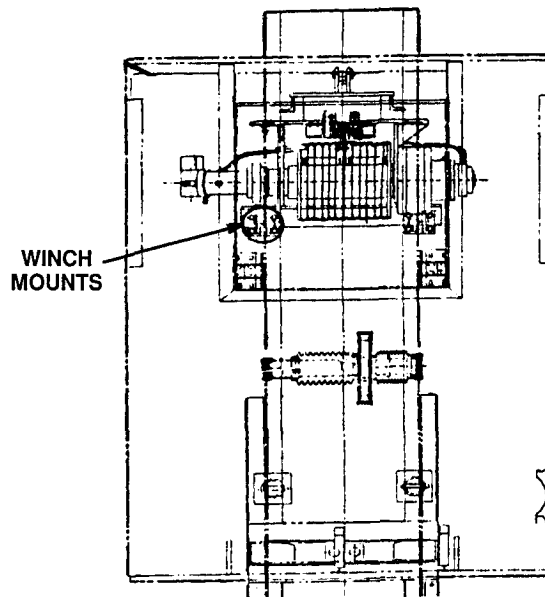


Table 2-2. Unit Level Preventive Maintenance Checks And Services

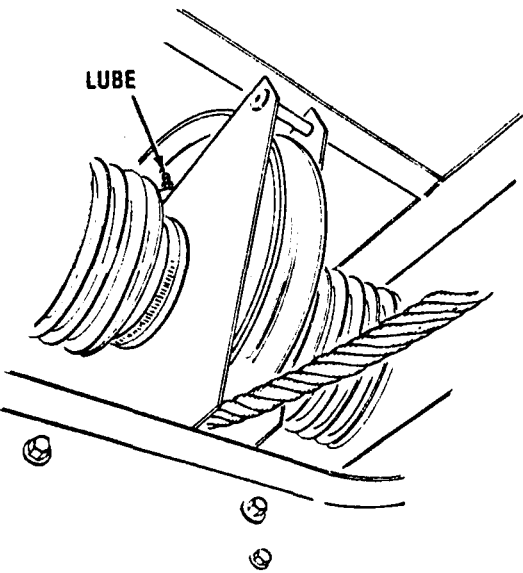
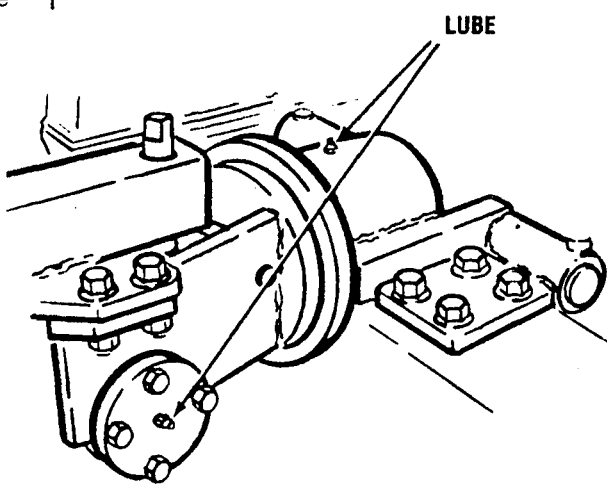
| Item No. | Interval | Item To Be Inspected | Procedure | Not Mission Capable If: |
|----------|-------------|--|---|---|
| 23 | Semi-Annual | M984A1 Heavy Duty Recovery Winch Cable Guide Assembly | Lubricate pulley hub fitting with GAA.  | Fittings will not purge old lubricant out of component. |
| 24 | Semi-Annual | Fairlead Tensioner and Sheave | Lubricate fairlead tensioner and sheave with GAA.  | Fittings will not purge old lubricant out of component. |

Table 2-2. Unit Level Preventive Maintenance Checks and Services

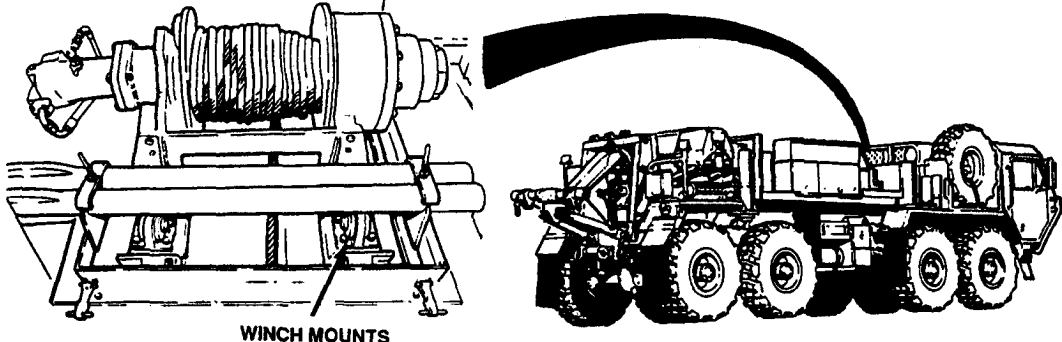
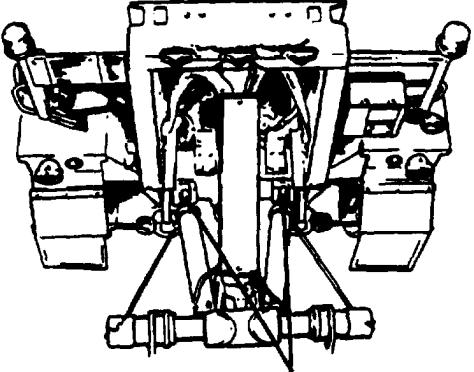
| Item No. | Interval | Item To Be Inspected | Procedure | Not Mission Capable If: |
|--|-------------|--|---|---|
| 25 | Semi-Annual | M984A1 Heavy Duty Recovery Winch Continued Drum Gear Box | Check oil level of the drum gearbox and fill as required. | |
| 26 | Semi-Annual | Winch Mounting Pins | Check three winch mounts for missing or damaged mounting pins. | Mounting pins missing or damaged. |
|  <p data-bbox="607 1330 761 1357">WINCH MOUNTS</p> | | | | |
| 27 | Semi-Annual | Hydraulic Hoses | Inspect hydraulic hoses for splits, cracks, leaks or signs of damage. | Splits, cracks, or Class III leaks evident. |

Table 2-2. Unit Level Preventive Maintenance Checks And Services

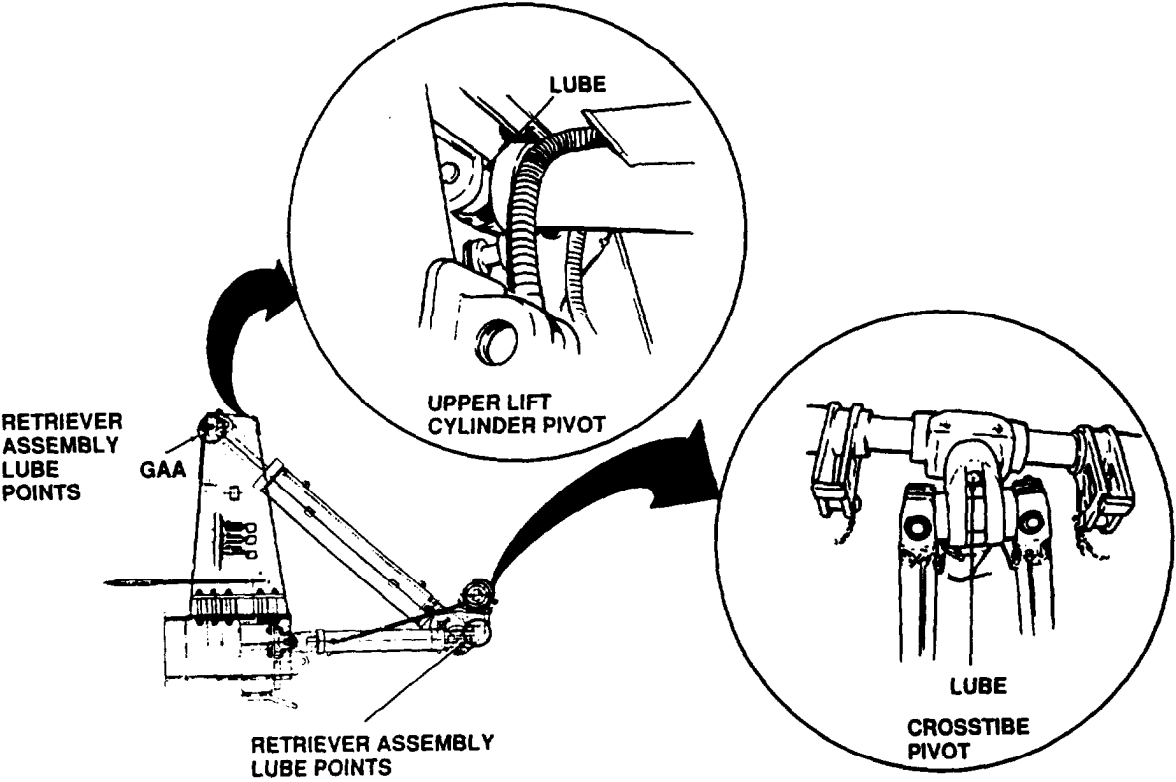
| Item No. | Interval | Item To Be Inspected | Procedure | Not Mission Capable If: |
|----------|-------------|--|---|---|
| 28 | Semi-Annual | M984A1 Heavy Duty Recovery Winch Continued Pressure Roller Springs | Inspect pressure roller for missing or damaged springs. Check that rollers turn freely and there is no binding on winch drum when operating. Check roller tensioner springs for damage. | Springs missing or damaged, rollers binding, or roller tensioner springs damaged. |
| | | | | |
| 29 | Semi-Annual | Cable U-Bolt Nuts | Tighten cable U-bolt nuts alternately and evenly until both nuts are tight. | |
| 30 | Semi-Annual | Winch Cable Tension | Release tension on winch cable (TM 9-2320-279-10). Inspect cable guide assembly for damage. Sheave pulley must rotate and slide freely on shaft. | Sheave pulley does not rotate or slide freely. |

Table 2-2. Unit Level Preventive Maintenance Checks and Services

| Item No. | Interval | Item To Be Inspected | Procedure | Not Mission Capable If: |
|----------|-------------|---|---|-------------------------|
| 31 | Semi-Annual | M984A1 Retriever Assembly Lube Points | Lubricate retriever assembly with GM. NOTE Lubricate every 1500 hours or semiannually, whichever comes first. | |



**RETRIEVER ASSEMBLY
LUBE POINTS**



**RETRIEVER ASSEMBLY
LUBE POINTS**

GAA

**UPPER LIFT
CYLINDER PIVOT**

LUBE

**RETRIEVER ASSEMBLY
LUBE POINTS**

LUBE

**CROSSTIBE
PIVOT**

Table 2-1. Unit Level Preventive Maintenance Checks and Services

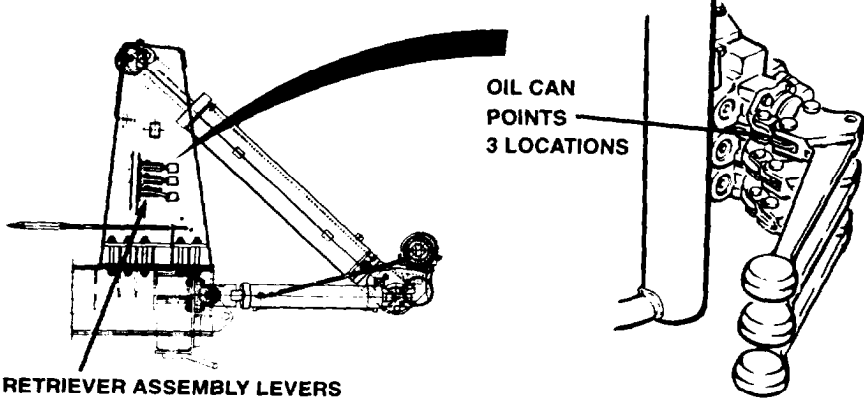
| Item No. | Interval | Item To Be Inspected | Procedure | Not Mission Capable If: |
|----------|-----------------|---|---|-------------------------|
| 32 | Semi-Annual | M984E1 Retriever Assembly Levers | <p>Lubricate all pivots of control levers with an oil can using OE/HDO.</p>  <p style="text-align: center;">RETRIEVER ASSEMBLY LEVERS</p> | |
| | M984E1 Crane | <p style="text-align: center;">NOTE</p> <p>Load testing of cranes is required before initial use of all new cranes, cranes that have been extensively repaired, cranes that have undergone modification or alteration, and cranes that have remained idle six or more months.</p> <p>Refer crane to next higher level of maintenance for load testing.</p> | Crane does not meet load test requirements. | |

Table 2-1. Unit Level Preventive Maintenance Checks and Services

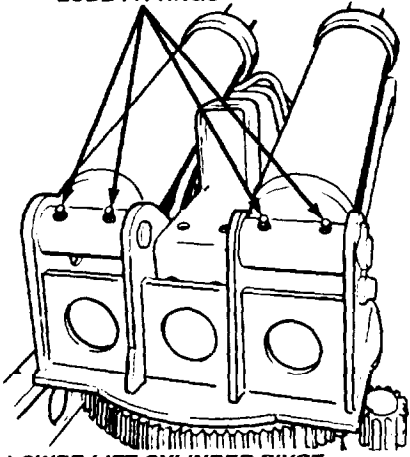
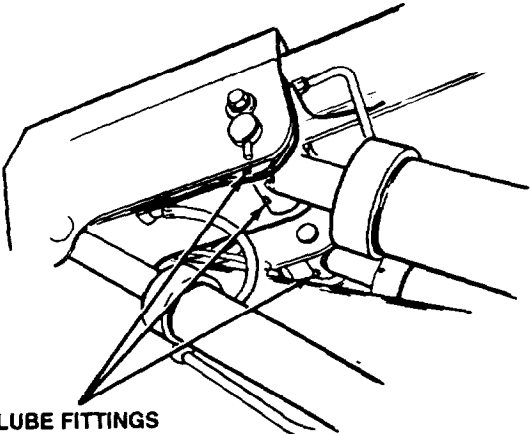
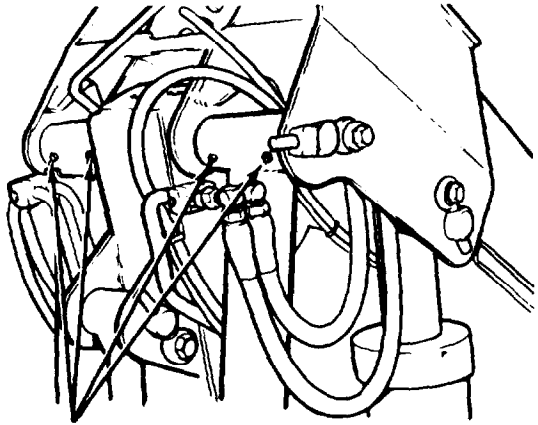
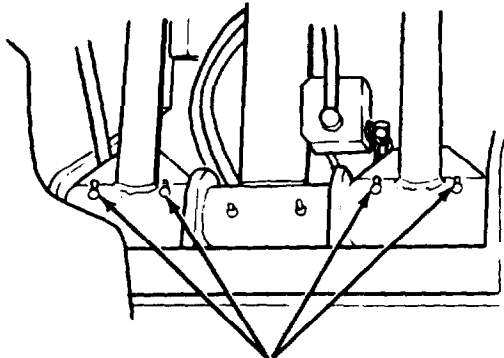
| Item NO. | Interval | Item To Be Inspected | Procedure | Not Mission Capable If: |
|--|-------------|---|---|---|
| 33 | Semi-Annual | M984E1 Crane Continued Lift cylinder Pivot | <p style="text-align: center;">NOTE</p> <p style="text-align: center;">Purging of lubricant.</p> <p>When using a grease gun, apply lubricant to the fitting until clean lubrication squeezes out of the fitting being lubricated.</p> <p>Lubricate both ends of lift cylinders with GAA.</p> | Fittings will not purge old lubricant out of component. |
| <div style="display: flex; justify-content: space-around; align-items: flex-start;"> <div style="text-align: center;"> <p>LUBE FITTINGS</p>  <p>LOWER LIFT CYLINDER PIVOT</p> </div> <div style="text-align: center;">  <p>LUBE FITTINGS</p> <p>UPPER LIFT CYLINDER PIVOT</p> </div> </div> | | | | |
| 34 | Semi-Annual | Tension Link Pivot | Lubricate both ends of the tension links with GAA. | Fittings will not purge old lubricant out of component. |
| <div style="display: flex; justify-content: space-around; align-items: flex-start;"> <div style="text-align: center;">  <p>LUBE FITTINGS</p> <p>UPPER TENSION LINK PIVOT</p> </div> <div style="text-align: center;">  <p>LUBE FITTINGS</p> <p>LOWER TENSION LINK PIVOT</p> </div> </div> | | | | |

Table 2-2. Unit Level Preventive Maintenance Checks And Services

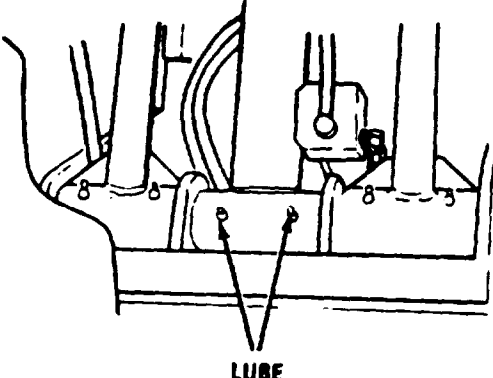
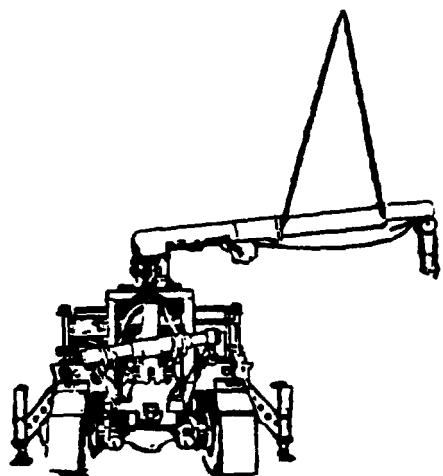
| Item No. | Interval | Item To Be Inspected | Procedure | Not Mission Capable If: |
|----------|-------------|--|--|---|
| 35 | Semi-Annual | M984A1 Crane Continued Erection Cylinder Pivot | Lubricate the lower ends of erection cylinder with GAA.  <p style="text-align: center;">LUBE</p> <p style="text-align: center;">NOTE Lubricate outrigger bottom plate, boom wear pads and exposed rotation gears often when cranes are operated in sandy or dusty areas.</p> | Fittings will not purge old lubricant out of component. |
| 36 | Semi-Annual | Boom Wear Pads | Clean sliding surfaces boom wear pads and lubricate by coating with GAA. <p style="text-align: center;">BOOM WEAR PADS</p>  | |

Table 2-2. Unit Level Preventive Maintenance Checks and Services

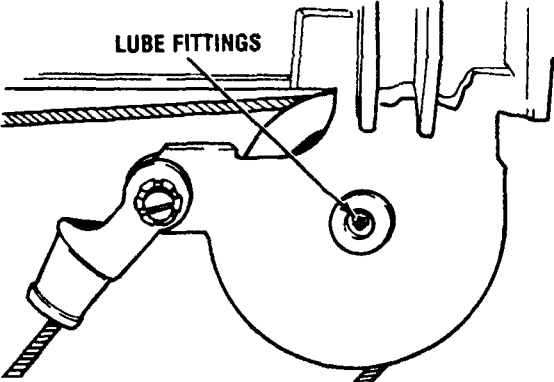
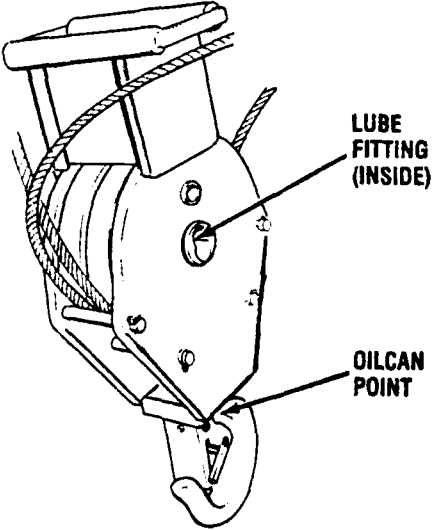
| Item No. | Interval | Item To Be Inspected | Procedure | Not Mission Capable If: |
|----------|-------------|---|---|---|
| 37 | Semi-Annual | M984A1 Crane Continued Boom Nose Sheave | Lubricate boom nose sheave bushing with GAA.  M984A1 HAS TWO FITTINGS. ONE ON EACH SIDE. | Fittings will not purge old lubricant out of component. |
| 38 | Semi-Annual | Hook Block Sheave | Lubricate hook block sheave bushing with GAA.  | Fittings will not purge old lubricant out of component. |

Table 2-2. Unit Level Preventive Maintenance Checks And Services

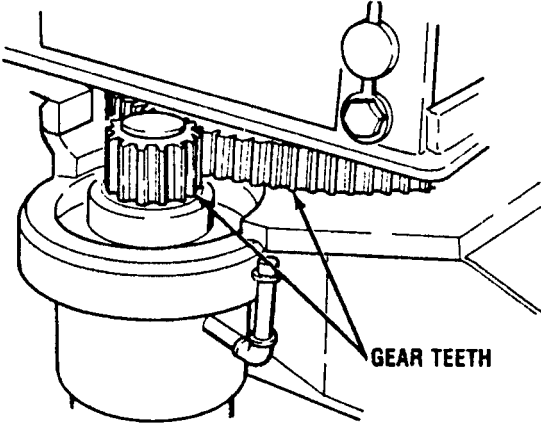
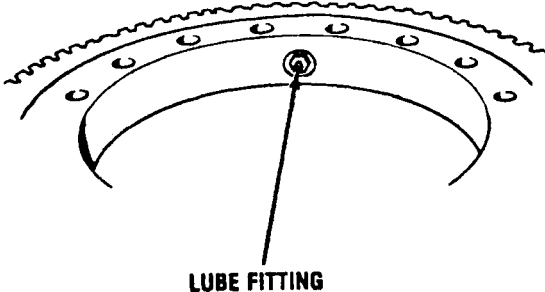
| Item No. | Interval | Item To Be Inspected | Procedure | Not Mission Capable If: |
|----------|-------------|---|---|---|
| 39 | Semi-Annual | M984A1 Crane Continued Rotation Gear and Pinion Teeth | <p style="text-align: center;">NOTE</p> <p>Lubricate outrigger bottom plate, boom wear pads and exposed rotation gears often when cranes are operated in sandy or dusty areas.</p> <p style="text-align: center;">NOTE</p> <p>Lubricate after high pressure wash.</p> <p>Coat external teeth of rotation gear lightly with GAA.</p>  | Lube contaminated. |
| 40 | Semi-Annual | Turntable Bearing | <p>Raise mast until lube fitting comes into view. Turn and lubricate with GAA. Turn table every 90 degrees until you have turned the turntable 360 degrees. Then rotate the crane a full 360 degrees to spread the lubricant.</p>  | Fittings will not purge old lubricant out of component. |

Table 2-2. Unit Level Preventive Maintenance Checks and Services

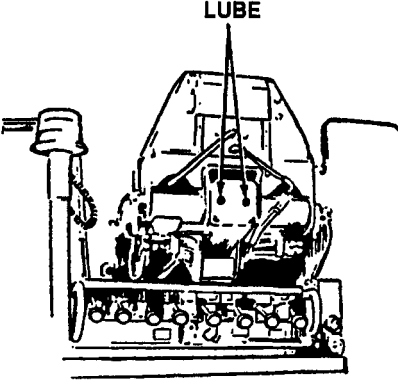
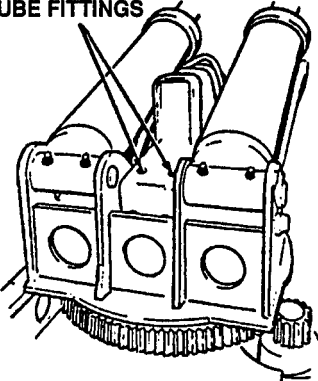
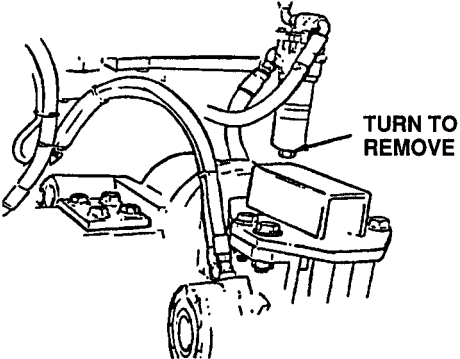
| Item No. | Interval | Item To Be Inspected | Procedure | Not Mission Capable If: |
|----------|-------------|---|---|--|
| 41 | Semi-Annual | M984A1 Crane Continued Mast Pivot | Lubricate both ends of mast with GAA. | Fittings will not purge old lubricant out of component. |
| 42 | Semi-Annual | Outrigger Bottom Plate | <p>LUBE</p>  <p>LUBE FITTINGS</p>  <p>NOTE Lubricate outrigger bottom plate, boom wear pads and exposed rotation gears often when cranes are operated in sandy or dusty areas.</p> <p>Clean sliding surfaces of outrigger bottom plate and lubricate with GAA.</p> <p>NOTE Hydraulic fluid and filters will change only when they are known to be contaminated, clogged or when service is recommended by AOAP laboratory.</p> | Faulty oil results received from AOAP lab. "Do not operate". |
| 43 | Semi-Annual | Hydraulic Fluid Filter | <p>Replace crane hydraulic fluid filter (paragraph 19-17).</p>  | |

Table 2-2. Unit Level Preventive Maintenance Checks And Services

| Item No. | Interval | Item To Be Inspected | Procedure | Not Mission Capable If: |
|----------|-------------|--|--|--|
| 44 | Semi-Annual | M984A1 Crane Continued Material Handling Crane | <p>a. While operating crane, check that engine governor maintains 1,500 + or -25 rpm during hoisting operation.</p> <p>b. With boom raised, check cylinder piston rods for bends and scoring.</p> <div data-bbox="475 934 1070 1270" style="text-align: center;"> <p>CYLINDER PISTON RODS</p> </div> <p>c. Inspect all hydraulic lines and hoses for splits, cracks, or signs of wear.</p> | <p>a. Engine surges erratically, governor does not maintain 1,500 + or -25 rpm.</p> <p>b. Piston rods bent or scored.</p> <p>c. Class III leaks evident.</p> |

Table 2-2. Unit Level Preventive Maintenance Checks and Services

| Item No. | Interval | Item To Be Inspected | Procedure | Not Mission Capable If: |
|----------|-------------|---|---|---|
| 45 | Semi-Annual | M984A1 Crane Continued Outrigger Pads | <p style="text-align: center;"><u>WARNING</u></p> <p>Adhesives, solvents, and sealing compounds can burn easily, can give off harmful vapors, and are harmful to skin and clothing. To avoid injury or death, keep away from fire and use in well-ventilated area. If adhesive, solvents, or sealing compounds get on skin or clothing, wash immediately with soap and water.</p> <p>a. Clean all metal parts with dry cleaning solvent.</p> <p style="text-align: center;"><u>WARNING</u></p> <p>Compressed air used for cleaning purposes will not exceed 30 psi (207 kPa). Use only with effective chip guarding and personal protective equipment, goggles, shield, and gloves.</p> <p>b. Dry metal parts with compressed air.</p> <p>c. Inspect metal parts for breaks, cracks, and sharp edges.</p> | Outrigger pad broken, cracked or missing. |

Table 2-2. Unit Level Preventive Maintenance Checks And Services

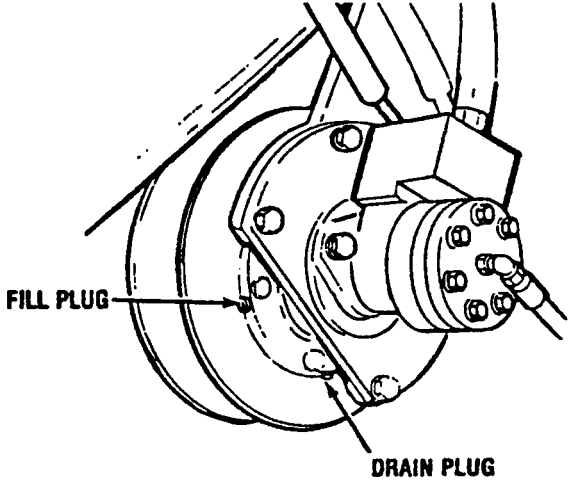
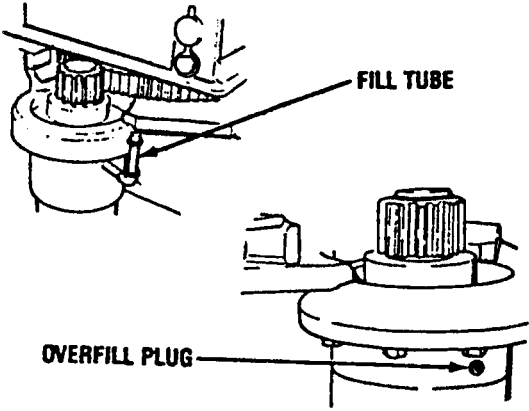
| Item No. | Interval | Item To Be Inspected | Procedure | Not Mission Capable If: |
|----------|----------|---------------------------------|---|-------------------------|
| 46 | Annual | M977 and M985 Crane Hoist Drive | <p>Check oil at fill plug. Add oil (GO) as required at fill hole.</p>  <p>The diagram shows a perspective view of a crane hoist drive. A cylindrical component is mounted on a larger housing. Two arrows point to specific features: one labeled 'FILL PLUG' pointing to a small circular opening on the side of the cylinder, and another labeled 'DRAIN PLUG' pointing to a similar opening on the bottom of the cylinder.</p> | |
| 47 | Annual | Swing Drive Gearbox | <p>Check oil level at overfill hole. Add oil (GO) as required at fill tube.</p>  <p>The diagram shows two views of a swing drive gearbox. The top view shows a gear assembly with a 'FILL TUBE' extending from the top. The bottom view shows the side of the gearbox with an 'OVERFILL PLUG' located on the lower part of the housing.</p> | |

Table 2-1. Unit Level Preventive Maintenance Checks and Services

| Item No. | Interval | Item To Be Inspected | Procedure | Not Mission Capable If: |
|----------|----------|--|--|--|
| 48 | Annual | M977 and M985 Crane Continued Turntable Bearing Screws | Check all turntable bearing screws for looseness. If loose, tighten screws to 370 lb-ft (502 N°m). | Screws will not torque to 370 lb-ft (502 N°m). |
| 49 | Annual | M984 Magnetic Drain Plug | Remove magnetic drain plug, clean and replace. | |
| 50 | Deleted | M984E 1 Crane | | |
| 51 | Annual | Swing Drive Gearbox | Check oil level at overfill hole. Add oil (GO) as required at fill tube. | |

Table 2-2. Unit Level Preventive Maintenance Checks And Services

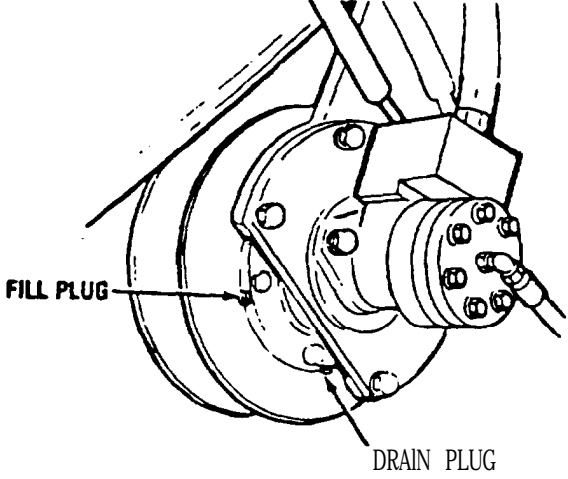
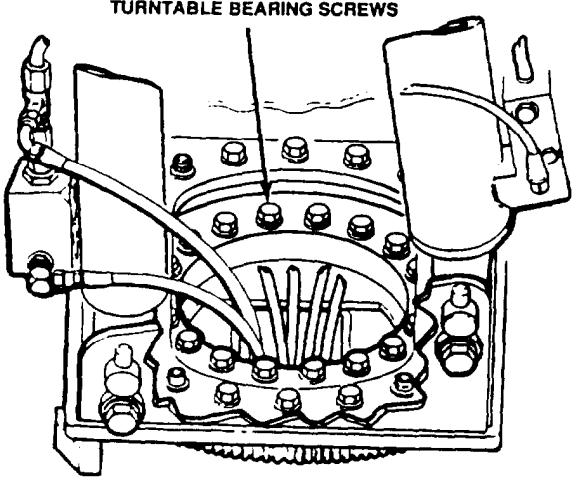
| Item No. | Interval | Item To Be Inspected | Procedure | Not Mission Capable If: |
|----------|----------|--|---|---|
| 52 | Annual | M984A1 Crane Continued Crane Hoist Drive | <p>Check oil at fill plug. Add oil (GO) as required at fill hole.</p>  <p>The diagram shows a cross-section of a crane hoist drive. A central shaft is surrounded by a housing. On the left side, there is a circular cover with two small circular openings. One is labeled 'FILL PLUG' and the other is labeled 'DRAIN PLUG'. A dipstick is shown inserted into the fill plug. On the right side, there is a cylindrical component with several bolts around its circumference.</p> | |
| 53 | Annual | Turntable Bearing Screws | <p>Check all turntable bearing screws for looseness. If loose, tighten screws to 370 lb-ft (502 N^om)</p>  <p>The diagram shows a top-down view of a turntable bearing assembly. It features a central hub with several vertical rollers or bearings. The entire assembly is mounted on a base plate. Numerous screws are visible around the perimeter of the base plate, which are labeled 'TURNTABLE BEARING SCREWS'. A dipstick is shown inserted into the central hub area.</p> | Screws will not torque to 370 lb-ft (502 N ^o m). |

Table 2-2. Unit Level Preventive Maintenance Checks and Services

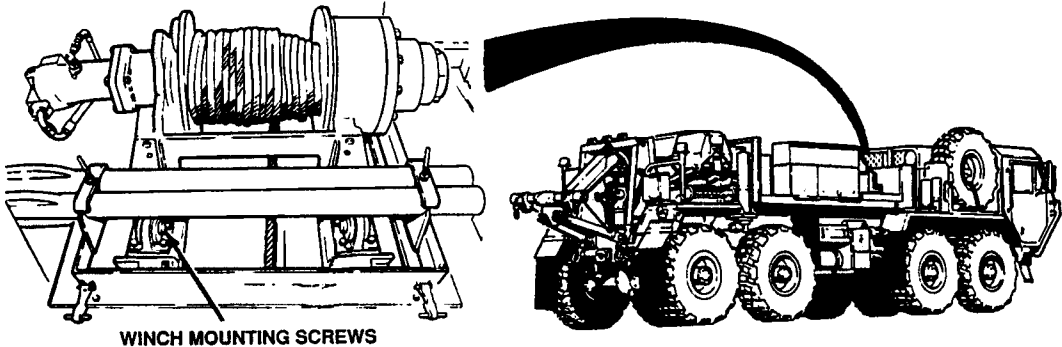
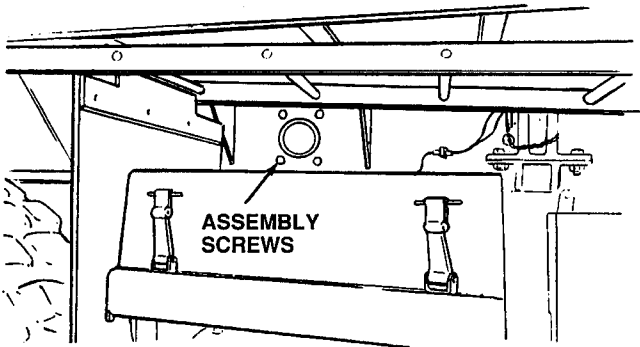
| Item No. | Interval | Item To Be Inspected | Procedure | Not Mission Capable If: |
|---|----------|--|--|---|
| 56 | Annual | M984A1 Crane Continued Winch Mounting Screws | a. Tighten winch mounting screws to 375 lb-ft (509 N·m). | a. Screws will not torque to 375 lb-ft (509 N·m). |
| <div style="display: flex; justify-content: space-around; align-items: center;">  </div> | | | | |
| | | | b. Tighten cable guide assembly screws to 212 lb-ft (287 N·m). | b. Screws not torqued to 212 lb-ft (287 N·m). |
| <div style="display: flex; justify-content: center; align-items: center;">  </div> | | | | |

Table 2-2. Unit Level Preventive Maintenance Checks And Services

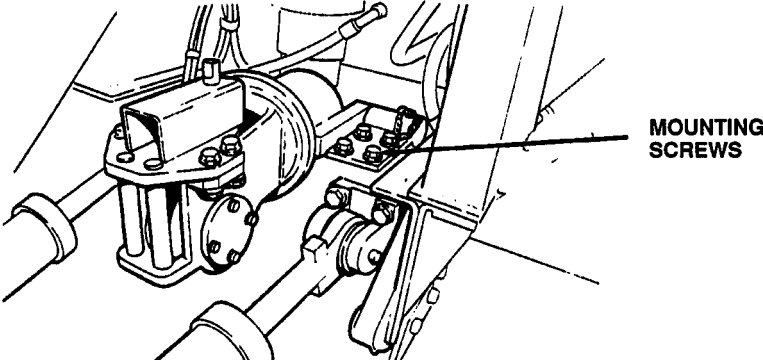
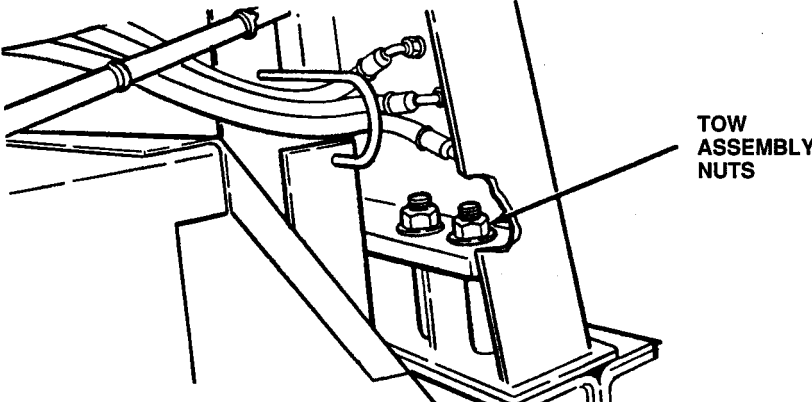
| Item No. | Interval | Item To Be Inspected | Procedure | Not Mission Capable If: |
|---|----------|---|--|--|
| 57 | Annual | M984A1 Continued Fairlead Mounting Screws | Tighten fairlead mounting screws to 375 lb-ft (509 N·m). | Screws not torqued to 212 lb-ft (287 N·m). |
|  <p>A technical line drawing showing a fairlead assembly mounted on a structure. Several screws are visible, securing the assembly. A leader line points to one of these screws with the label 'MOUNTING SCREWS'.</p> | | | | |
| 58 | Annual | Retriever Assembly | a. Tighten tow assembly nuts to 460 lb-ft (624 N·m). | a. Toe assembly support nuts not torqued to 460 lb-ft (624 N·m). |
|  <p>A technical line drawing of a tow assembly. Two nuts are shown on a horizontal bar. A leader line points to these nuts with the label 'TOW ASSEMBLY NUTS'.</p> | | | | |

Table 2-2. Unit Level Preventive Maintenance Checks and Services

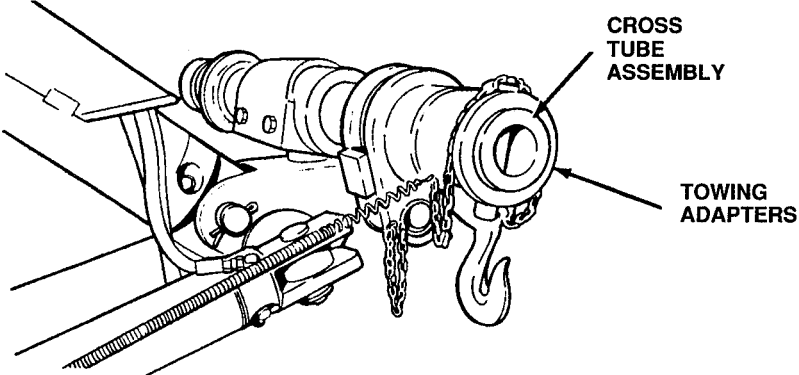
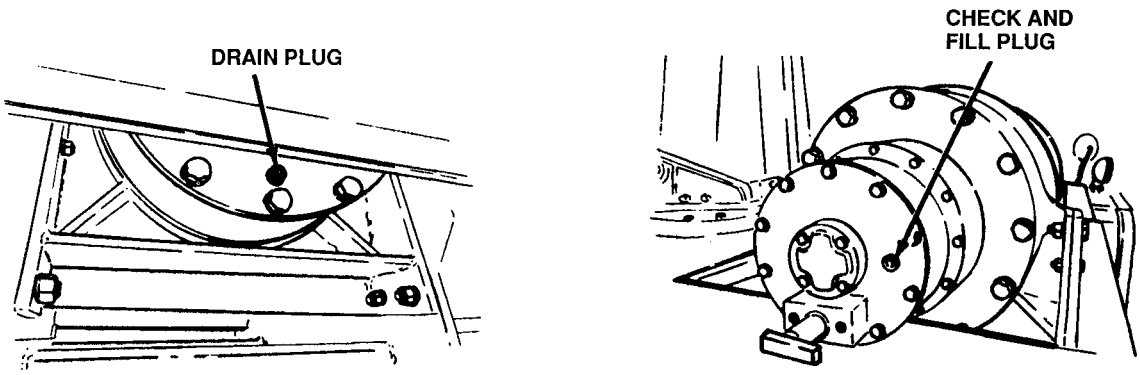
| Item No. | Interval | Item To Be Inspected | Procedure | Not Mission Capable If: |
|--|------------|--|--|---|
| 58 | Annual | M984A1 Continued Retriever Assembly Continued | b. Inspect for bent or damaged cross tube assembly. Towing adapters should slide on and off easily. | b. Cross tube assembly bent or damaged. Towing adapters don't slide easily. |
|  | | | | |
| 59 | Biennially | M984 Drum Gear Box | c. Inspect all hydraulic lines and hoses for splits, leaks, and signs of wear. Drain and refill drum to required level. | c. Splits, cracks or leaks evident. |
|  | | | | |

Table 2-2. Unit Level Preventive Maintenance Checks and Services

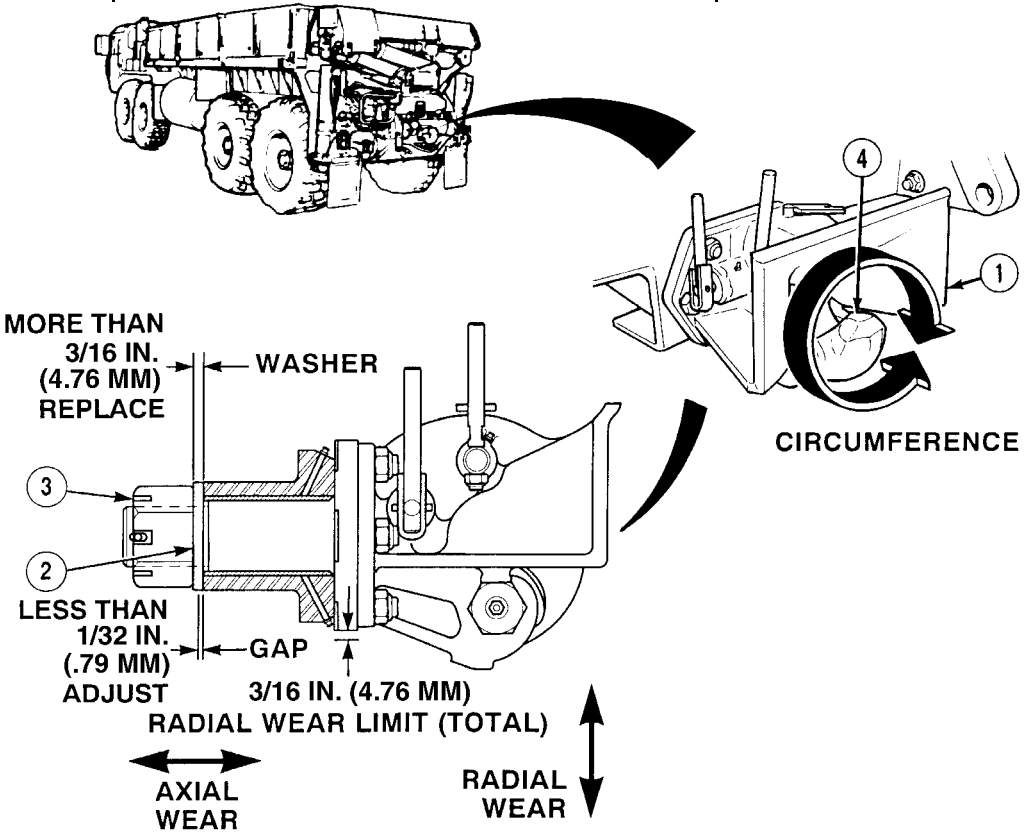
| Item No. | Interval | Item To Be Inspected | Procedure | Not Mission Capable If: |
|----------|-------------|--|--|--|
| 59.1 | Semi-Annual | M1977-CBT, M1120 LHS Only Self-Guided Coupler |  <p>Check self-guided coupler (1) for cracks, damage, or excessive wear. Replace coupler if cracked or damaged. If radial wear exceeds 3/16 in. (4.76 mm) total, replace coupler before next mission. If axial clearance exceeds 1/32 in. (.79 mm), measure thickness of washer (2). If washer (2) thickness is under 3/16 in. (4.76 mm), replace washer. If washer thickness is larger than 3/16 in. (4.76 mm), adjust nut (3). Refer to Para 14-15.01.</p> <p>If circumference at worn area of coupler jaw (4) is less than 8-1/2 in. (215.9 mm), replace coupler at next scheduled service. If circumference is less than 8-1/4 in. (209.6 mm), replace coupler before next mission. Refer to Para 14-15.01.</p> | <p>Radial wear exceeds 3/16 in. (4.76 mm).</p> <p>Washer thickness is less than 3/16 in. (4.76 mm).</p> <p>Circumference at worn area is less than 8-1/4 in. (209.6 mm).</p> |

Table 2-3. Unit Level Preventive Maintenance Checks and Services Auxiliary Equipment

| Item No. | Interval | Item To Be Inspected | Procedure | Not Mission Capable If: |
|----------|-------------|---|---|--|
| 2 | Semi-Annual | Self-Recovery Winch Continued Front Cable Guide | <p style="text-align: center;">NOTE</p> <p style="text-align: center;">Purging of lubricant.</p> <p>When using a grease gun, apply lubricant to the fitting until clean lubrication squeezes out of the fitting being lubricated.</p> <p>Inspect presence and condition of four lube fittings and lube with GAA as required.</p> | Fitting will not purge old lubricant out of component. |
| 3 | Semi-Annual | Front and Rear Cable Tensioner | <p>a. Inspect presence and condition of rollers lube fittings and lube with GAA as required.</p> <p>b. Lubricate pivots and pressure rollers at oil can points with OE/HDO as required.</p> | Fitting will not purge old lubricant out of component. |

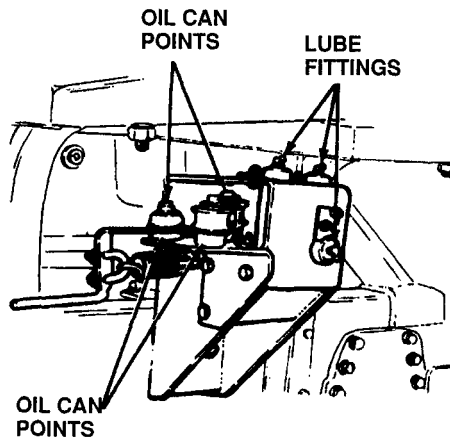
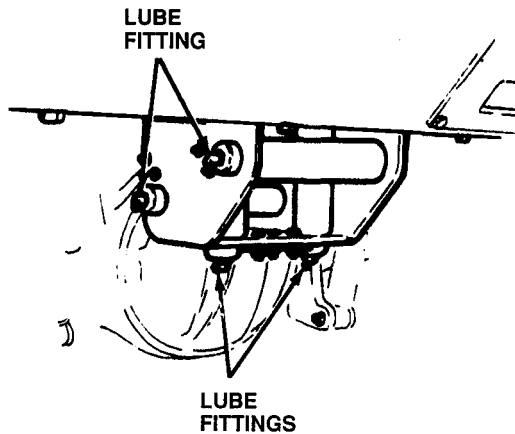


Table 2-3. Unit Level Preventive Maintenance Checks And Services Auxiliary Equipment

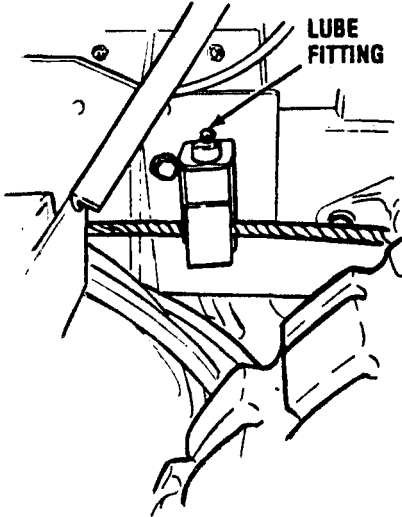
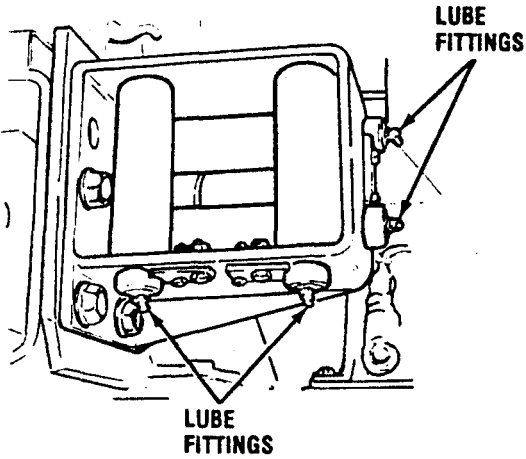
| Item No. | Interval | Item To Be Inspected | Procedure | Not Mission Capable If: |
|----------|-------------|---|---|--|
| 4 | Semi-Annual | Self-Recovery Winch Continued Small Cable Guide | Inspect and lubricate roller with GAA as required (M978, M983 and M984).  | Fitting will not purge old lubricant out of component. |
| 5 | Semi-Annual | Rear Cable Guide | Inspect and lubricate four fittings with GAA as required (except M984A1).  | Fitting will not purge old lubricant out of component. |

Table 2-3. Unit Level Preventive Maintenance Checks and Services Auxiliary Equipment

| Item No. | Interval | Item To Be Inspected | Procedure | Not Mission Capable If: |
|--|-------------|---|---|-------------------------|
| 6 | Semi-Annual | Self-Recovery Winch Continued Winch Mount Screws | Tighten four winch screws (1) to 110 lb-ft (150 N·m). Tighten eight winch mounting screws (2) to 210 lb-ft (285 N·m). Tighten sixteen winch mounting screws (3) to 55 lb-ft (74 N·m). Tighten two winch brake mounting screws (4) to 110 lb-ft (150 N·m). | Screws will not torque. |
| <p>The diagram shows a winch with a cable spool. Four screws (1) are located on the front face of the winch housing. Eight screws (2) are arranged in two rows on the side of the housing. Sixteen screws (3) are distributed across the top and sides of the winch drum. Two screws (4) are located on the brake assembly at the rear of the winch.</p> | | | | |
| 7 | Semi-Annual | Machine Gun Mount | Refer to TM 9-1005-245-14 for preventive maintenance checks and services. | |
| 8 | Semi-Annual | M-8 Chemical Alarm | Refer to TM 3-6665-12 for preventive maintenance checks and services. | |
| 9 | Semi-Annual | M-13 Decontamination Unit | Refer to TM 3-4230-214-12&P for preventive maintenance checks and services. | |
| 10 | Semi-Annual | Radio | Refer to TM 11-5820-498-12 for preventive maintenance checks and services. | |
| 11 | Semi-Annual | Generator Set | Refer to TM 5-6115-465-12 for preventive maintenance checks and services. | |

Table 2-3. Unit Level Preventive Maintenance Checks And Services Auxiliary Equipment

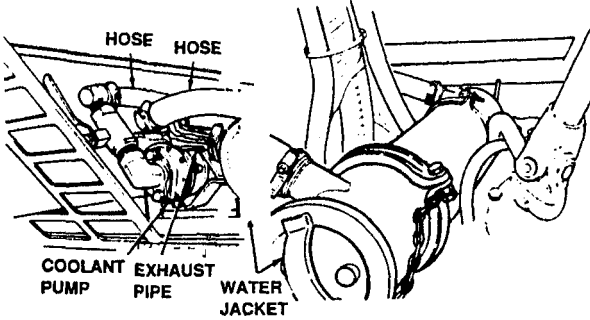
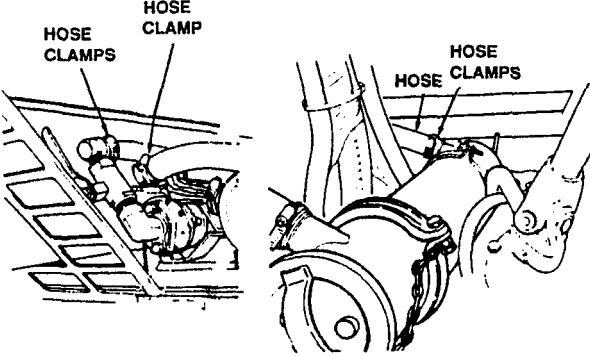
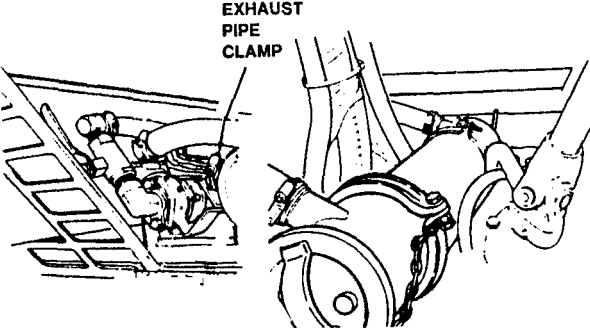
| Item No. | Interval | Item To Be Inspected | Procedure | Not Mission Capable If: |
|----------|----------|--------------------------|--|---|
| 12 | Annual | Engine Arctic Heater Kit | <p>a. Check coolant pump, hoses, exhaust pipe and area around water jacket for leaks, cuts, tears, and other obvious damage.</p>  <p>b. Check hose clamps for looseness or damage.</p>  <p>c. Check exhaust pipe clamp for looseness or damage.</p>  | <p>a. Leaks, cuts, tears evident.</p> <p>b. Looseness or damage evident.</p> <p>c. Looseness or damage evident.</p> |

Table 2-3. Unit Level Preventive Maintenance Checks and Services Auxiliary Equipment

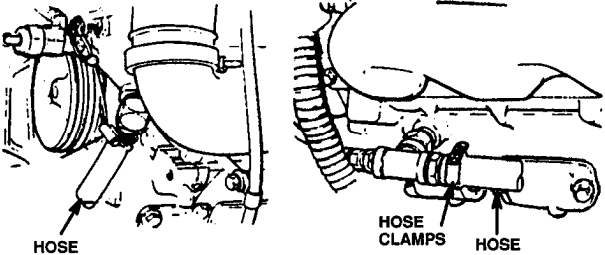
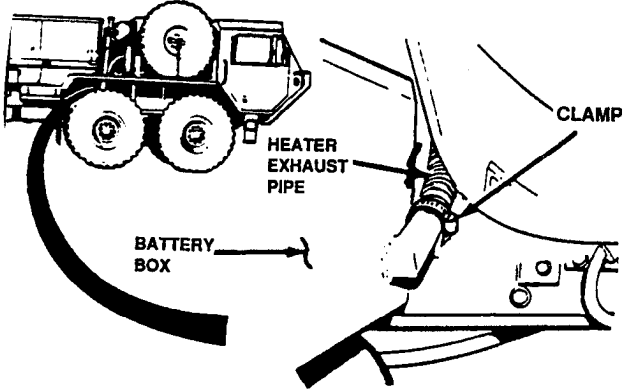
| Item No. | Interval | Item To Be Inspected | Procedure | Not Mission Capable If: |
|----------|----------|---|--|---|
| 12 | Annual | Engine Arctic Heater Kit Continued | <p>d. Check coolant hoses at engine for leaks, cuts, tears, and other obvious damage. Check hose clamps for looseness or damage.</p>  <p>e. Check heater exhaust pipe at battery box for loose clamp, leaks, cuts, tears, and other obvious damage.</p>  | <p>d. Leaks, cuts or tears evident.</p> <p>e. Leaks, cuts or tears evident.</p> |

Table 2-3. Unit Level Preventive Maintenance Checks And Services Auxiliary Equipment

| Item No. | Interval | Item To Be Inspected | Procedure | Not Mission Capable If: |
|---|----------|------------------------------------|---|---|
| 13 | Annual | Gas Particulate Filter Unit (GPFU) | <p>a. Inspect hoses for cuts, tears and other obvious damage.</p> <p>b. Inspect hose clamps and GPFU mounts for looseness or damage.</p> | <p>Hoses are cut torn or damaged if required for mission.</p> <p>Hose clamps and GPFU mounts are loose or damaged and required for mission.</p> |
| <p>The diagram shows a side view of the Gas Particulate Filter Unit (GPFU) assembly. It features two main vertical hoses connected to the top of the unit. Labels with arrows point to 'GPFU MOUNTS' at the top connections, 'HOSE CLAMPS' on the side of the hoses, and 'HOSES' for the main vertical pipes. The unit is mounted on a base with various electrical and fluidic connectors.</p> | | | | |
| 14 | Annual | Rifle Mounting Kit | <p>a. Inspect top mount and lower mount for looseness or damage.</p> <p>b. Inspect handle for excessive looseness, binding or damage.</p> | <p>Loose or damaged and required for mission.</p> <p>Loose or damaged and required for mission.</p> |

M977 SERIES PMCS PARTS LIST

SEMIANNUAL (3,000 MILES)

| ITEM NO. | <u>PART NUMBER</u> | <u>STOCK NUMBER</u> | <u>NOMENCLATURE</u> | QTY |
|---------------------|-------------------------------|--------------------------------|---|------------|
| 1. | HC7500Y 144 | 4330-01-217-8184 | Filter Element, Fluid (M977/M985 Only) | 1 |
| 2. | HD223 | 2940-01-132-4842 | Filter Element, Fluid | 1 |
| 3. | MS35338-46 | 5310-00-637-9541 | Washer, Lock (All Except M984EI) | 2 |
| 4. | MS35802-3 | 2940-00-580-6283 | Filter Element, Fluid | 1 |
| 5. | S-268-1 | 5306-01-084-5390 | Bolt, Machine (All Except (M984EI) | 2 |
| 6. | WA110 | 5310-01-061-5302 | Washer, Lock | 4 |
| 7. | 10232C | 5330-01-168-8707 | Gasket (M978 Only) | 1 |
| 8. | 11007 | 5330-01-046-1990 | Gasket | 1 |
| 9. | 1112310 | 5330-01-225-4803 | Packing, Preformed (M977/ M985/M984EI Only) | 1 |
| 10. | 1124510 | 5330-0111 43-0135 | Packing, Preformed (M977/ M985/M984EI Only) | 1 |
| 11. | 1128242 | 5330-01-124-1112 | Packing, Preformed (M977/ M985/M984EI Only) | 1 |
| 12. | 11350 | 5330-01-147-6003 | Packing, Preformed | 1 |
| 13. | 1199478 | 5330-01-234-7625 | Gasket | 1 |
| 14. | 1199738 | 4330-01-192-7664 | Screen, Bypass Filter (M977/M985/M984EI Only) | 1 |
| 15. | 1300766 | 4330-01-232-8305 | Filter Element, Fluid (M984EI Only) | 1 |
| 16. | 1300767 | 4330-01-192-8832 | Filter Element, Fluid (M977/M985/M984EI Only) | 1 |
| 17. | 2020SM | 4330-01-046-3399 | Filter Element, Fluid | 1 |
| 18. | 2463HX | 5310-01-054-5896 | Washer, Flat (All Except M984EI) | 2 |
| 19. | 25010778 | 2900-01-022-8283 | Filter Element, Fluid | 1 |
| 20. | 4-1/2IN77 | 5330-01-163-5849 | Gasket (M978 Only) | 2 |
| 21. | 45D020P6 | 5330-01-156-3764 | Packing, Preformed (M978 Only) | 1 |
| 22. | 941107 | 4330-01-163-7326 | Filter Element, Fluid (M978 M983/M984/M985EI Only) | 1 |
| 23. | 253 | 2940-01-081-1301 | Kit, Dessicant Parts | 1 |

M977 SERIES PMCS PARTS LIST (Continued)

ANNUAL (6,000 MILES)

| ITEM NO | PART NUMBER | STOCK Number | NOMENCLATURE | QTY |
|---------|-------------|------------------|---|-----|
| 1 | HC7500Y144 | 4330-01-217-8184 | Filter Element, Fluid (M977/M985 Only) | 1 |
| 2. | HD223 | 2940-01-132-4842 | Filter Element, Fluid | 1 |
| 3. | MS35338-46 | 5310-00-637-9541 | Washer,-Lock (All Except M984A1) | 2 |
| 4. | MS35802-3 | 2940-00-580-6283 | Filter Element, Fluid | 1 |
| 5. | S-268-1 | 5306-01-084-5390 | Bolt, Machine (All Except M984A1) | 2 |
| 6. | WA110 | 5310-01-061-5302 | Washer, Lock | 4 |
| 7. | 10232C | 5330-01-168-8707 | Gasket (M978 only) | 1 |
| 8 | 11007 | 5330-01-046-1990 | Gasket | 1 |
| 9. | 1112310 | 5330-01-225-4803 | Packing, Preformed (M977/ M985/M984A1 Only) | 1 |
| 10. | 1124510 | 5330-01-143-0135 | Packing, Preformed (M977/ M985/M984A1 Only) | 1 |
| 11. | 1128242 | 5330-01-124-1112 | Packing, Preformed (M977/ M985/M984A1 Only) | 1 |
| 12. | 11350 | 5330-01-147-6003 | Packing, Preformed | 1 |
| 13. | 1199478 | 5330-01-234-7625 | Gasket | 1 |
| 14. | 1199738 | 4330-01-192-7664 | Screen, By-Pass Filter (M977/M985/M984A 1 Only) | 1 |
| 15. | 1300766 | 4330-01-232-8305 | Filter Element, Fluid (M984A1 Only) | 1 |
| 16. | 1300767 | 4330-01-192-8832 | Filter Element, Fluid (M977/M985/M984A1 Only) | 1 |
| 17. | 1313630 | 5330-01-152-7216 | Gasket | 1 |
| 18. | 2020SM | 4330-01-046-3399 | Filter Element, Fluid | 1 |
| 19. | 246HX | 5310-01-054-5896 | Washer, Flat (All Except M984A 1) | 2 |
| 20. | 25010778 | 2910-01-022-8183 | Filter Element, Fluid | 1 |
| 21. | 253 | 2940-01-081-1391 | Desiccant Parts Kit | 1 |
| 22. | 292236 | 5330-01-154-3997 | Packing, Preformed | 1 |
| 23. | 4-1/2IN77 | 5330-01-163-5849 | Gasket (M978 Only) | 2 |
| 24. | 45D020P6 | 5330-01-156-3764 | Packing, Preformed (M978 Only) | 1 |
| 25. | 941107 | 4330-01-163-7326 | Filter Element, Fluid (M978 M983/M984/M985E1 Only) | 1 |

M977 SERIES PMCS PARTS LIST (Continued)

BIENNIAL (12,000 MILES)

| <u>ITEM NO</u> | <u>PART NUMBER</u> | <u>STOCK NUMBER</u> | <u>NOMENCLATURE</u> | <u>QTY</u> |
|----------------|--------------------|---------------------|---|------------|
| 1. | HC7500Y144 | 4330-01-217-8184 | Filter Element, Fluid (M977/M985 Only) | 1 |
| 2. | HD223 | 2940-01-132-4842 | Filter Element, Fluid | 1 |
| 3. | MS35338-46 | 5310-00-637-9541 | Washer, Lock (All Except M984A1) | 2 |
| 4. | MS35802-3 | 2940-00-580-6283 | Filter Element, Fluid | 1 |
| 5. | S-268-1 | 5306-01-084-5390 | Bolt, Machine (All Except M984A1) | 2 |
| 6. | WA110 | 5310-01-061-5302 | Washer, Lock | 4 |
| 7. | 10232C | 5330-01-168-8707 | Gasket (M978 Only) | 1 |
| 8. | 11007 | 5330-01-046-1990 | Gasket | 1 |
| 9. | 1112310 | 5330-01-225-4803 | Packing, Preformed (M977/ M985/M984A1 Only) | 1 |
| 10. | 1124510 | 5330-01-143-0135 | Packing, Preformed (M977/ M985/M984A1 Only) | 1 |
| 11. | 1128242 | 5330-01-124-1112 | Packing, Preformed (M977/ M985/M984A1 Only) | 1 |
| 12. | 11350 | 5330-01-147-6003 | Packing, Preformed | 1 |
| 13. | 1199478 | 5330-01-234-7625 | Gasket | 1 |
| 14. | 1199738 | 4330-01-192-7664 | Screen, By-pass Filter (M977/M985/M984A1 Only) | 1 |
| 15. | 1300766 | 4330-01-232-8305 | Filter Element, Fluid (M984A1 Only) | 1 |
| 16. | 1300767 | 4330-01-192-8832 | Filter Element, Fluid (M977/M985/M984A1 Only) | 1 |
| 17. | 1313630 | 5330-01-152-7216 | Gasket | 1 |
| 18. | 2020SM | 4330-01-046-3399 | Filter Element, Fluid | 1 |
| 19. | 2463HX | 5310-01-054-5896 | Washer, Flat (All Except M984A1) | 2 |
| 20. | 25010778 | 2910-01-022-8183 | Filter Element, Fluid | 1 |
| 21. | 253 | 2940-01-081-1391 | Desiccant Parts Kit | 1 |
| 22. | 292236 | 5330-01-154-3997 | Packing, Preformed | 1 |
| 23. | 4-1/2 IN77 | 5330-01-163-5849 | Gasket (M978 Only) | 2 |

LUBRICATION TABLE

| LUBRICANTS | | EXPECTED TEMPERATURES | | | INTERVALS |
|---|--|--|-----------------------------|--|--|
| | | CAPACITIES | Above +15°F (Above -9°C) | +40°F to -15°F (+4°C to -26°C) | |
| LUBRICATING OIL ICE, TACTICAL OE/HDO (MIL-L-2194) LUBRICATING OIL ICE, ARCTIC OE/HDO (MIL-L-46167) | Engine W/Filter | 30 Qt (27L) | OE/HDO-15(36) | OE/HDO-15W/40 OEA see Note 1 and Note 7. | OE/HDO-15W140 OEA See Note I and Note 7. |
| | Transmission | 31 Qt (29L) | OE/HDO-10 | OE/HDO-10 | OEA |
| | Transfer Case | 5 Qt (5L) | OE/HDO-40 | OE/HDO-40 or OEA See Note 3. | OE/HDO-40 or OEA. See Note 3. |
| | Hydraulic Reservoir M984 W/Filter | 180 Qt (171L) | Above 60°F OE/HDO-30 | | OEA |
| | Models except M964E1 W/Filter | 120 Qt (114L) | OE/HDO-10 See Note 4. | OE/HDO-10 | |
| Oil Can Points | As req | OE/HDO-30 | OE/HDO-10 | OEA | |
| 30 MIL-L-2105 | LUBRICATING, OIL, Gear MULTIPURPOSE | | | | |
| | Crane Rotation Gearbox (M977) | 1 PI (0.5L) | GO-80W/99 | GO-80W/90 | GO-75 |
| | Crane Rotation Gearbox (M964E1, M965) | 2.5 PI (12L) | | | |
| | Crane Hoist (M977, M965, M984E1) | 1 PI (0.5L) | | | |
| | No. 1 Axle | See table I | GO-85W/140 | GO-85W/140 GO-80W/90 See Note 5. | GO+80W/90 GO-75 See Note 6. |
| | No. 2 Axle and Power Divider | See table I | | | |
| | No. 3 Axle and Power Divider | See table I | | | |
| No. 4 Axle GAA | See table I | | | | |
| Heavy Duty Winch Gearbox (M984, M964E1) | 12 Qt (11L) | GO-85W/140 | GO-75 GO-80W/90 | GO-75 | |
| Self-Recovery Winch Gearbox | 2 Qt (2L) | | | | |
| DRY CLEANING SOLVENT | | All temperatures | | | |
| ANTIFREEZE, ETHYLENE GLYCOL INHIBITED, HEAVY DUTY, SINGLE PACKAGE (MIL-A-46153) | 80 Qt (76L) | Use above -59°F (-46°C) | | | |
| ANTIFREEZE ARCTIC-TYPE (MIL-A-11755) | 80 Qt (76L) | Use when extended periods of -40°F (-40°C) and below are encountered. | | | |
| CORROSION INHIBITOR | 2.4 Qt (2.27L) | | | | |
| KEY VOTES | <p>1. OEA must be used when temperatures are consistently below 0°F (-18°C).</p> <p>2. OE/HDO-15W/40 must be used when temperatures are consistently above 0°F (-18°C).</p> <p>3. OE/HDO-40 must be used when temperatures are consistently above 9°F (-18°C).</p> <p>4. OE/HDO-30 must be used only when temperatures are consistently above 69°F (16°C).</p> <p>5. GO-85W/140 must be used when temperatures are consistently above 39°F (-1°C), GO 80W/90 must be used when temperatures are consistently above -15°F (-26°C).</p> <p>6. GO-80W/99 must be used when temperatures are consistently above -15°F (-26°C).</p> <p>7. After changing to OEA, drain one pint of oil from the oil sampling valve.</p> | | | | |

S - Semiannually
(6 Months)
A - Annually
B - Biennially
(2 Years)

LUBRICATION TABLE (Continued)

| LUBRICANTS | | CAPACITIES | EXPECTED TEMPERATURES | | |
|--|--|------------|-----------------------------|-----------------------------------|-----------------------------------|
| | | | Above +15°F (Above -9°C) | +40°F to -15°F (+4°C to -26°C) | +40°F to -50°F (+4°C to -46°C) |
| GAA (MIL-G-10924) | GREASE, AUTOMOTIVE AND ARTILLERY | As req | | | GAA All Temperatures |
| | Propeller Shafts and U-Joints | | | | |
| | Crane Pivot Points and Sheave | | | | |
| | Boom Wear Pads | | | | |
| | Crane Rotation Bearing | | | | |
| | Trunnion Bearings | | | | |
| | Brake Cam Slack | | | | |
| | Adjuster | | | | |
| | Spring Eye Pins | | | | |
| | Self-Recovery Winch, Cable Tensioner Rollers and Pivots | | | | |
| | Cable Guide Rollers | | | | |
| | Pintle Hook | | | | |
| | Wheel Bearings | | | | |
| | Steering System, Linkages, Trunnions, U-Joints, Tie Rods | | | | |
| | Tire Davit | | | | |
| | Mirror Assembly Swivel Joints | | | | |
| | Engine Throttle Air Cylinder | | | | |
| | Fifth Wheel Plate | | | | |
| | Fifth Wheel Ramp | | | | |
| | Slewing Cylinders (M983 Only) | | | | |
| | Crane Control Linkages (M983 Only) | | | | |
| | Tanker Reel Support Bearings (M978 Only) | | | | |
| | Retrieval System (M984A1 Only) | | | | |
| Wrecker Body Roll Mounts (M984A1 Only) | | | | | |
| Heavy-Duty Winch Mounts (M984A1 Only) | | | | | |
| Winch Cable Guide (M984A1 Only) | | | | | |
| Fairlead Assembly (M984A1 Only) | | | | | |

Table 1. Axle Capacities

| Vehicle Model | | Axle Number | | | |
|----------------------------|--------------------------------------|-----------------------|-------------------------|---------------------------|---------------------------|
| | | 1 | 2 | 3 | 4 |
| All | Axle Model No. Quarts (Liters) | RS480 17.5 (17) | DS480-P 21.5 (20) | | |
| M977, M978 M985, M985E1 | Axle Model No. Quarts Liters | | | DS480-P-CTD 21 (20) | RS480-CTD 16.5 (16) |
| M983 | Axle Model No. Quarts (Liters) | | | DS480-P 24 (23) | RS480 15.5 15 |
| M984 | Axle Model No. Quarts (Liters) | | | DT581-P 21.5 (20) | RT581 18 (17) |
| M984A1 | Axle Model No. Quarts (Liters) | | | DS650-P 21.5 (20) | RS650-P 22 (21) |

Section IV. TROUBLESHOOTING

2-14. TROUBLESHOOTING INTRODUCTION

This section contains step by step procedures for identifying, locating, isolating, and repairing equipment malfunctions.

2-15. TROUBLESHOOTING INSTRUCTIONS.

The System Symptom Index (Table 2-7) lists common malfunctions by vehicle system. The Troubleshooting Subject Index (Table 2-8) lists common malfunctions alphabetically. The Troubleshooting Procedures (Table 2-9) lists each malfunction followed by tests, inspections, and corrective actions. The Simplified Test Equipment for Internal Combustion Engines (STE/ICE) (para 2-16) contains procedures for operating the STE/ICE system to check out, test, and troubleshoot M977 series vehicle's internal combustion engines and associated fuel and electrical systems.

This manual cannot list all malfunctions that may occur, nor all tests or inspections and corrective actions. If a malfunction is not listed or is not corrected by listed corrective actions, notify the supervisor.

Before using troubleshooting tables, be sure all applicable Preventive Maintenance Checks and Services (PMCS) have been performed. Perform tests, inspections, and corrective actions in the order listed. Try to return the vehicle or component to operation after each test, inspection, and corrective action has been performed.

Refer to the figures, foldouts, and publications listed below while doing troubleshooting. These figures, foldouts, and additional publications will help isolate and locate troubles and get the vehicle back in service as quickly as possible. Foldouts are found at the end of this volume.

Figure 2-2 Circuit Breakers
 Figure 2-3 M986E1 HIGH IDLE Wiring Diagram
 Figure 2-4 M984 HIGH IDLE Wiring Diagram
 Figure 2-5 M984 HIGH IDLE Control Assembly
 Figure 2-6 M985E1 HIGH IDLE Control Assembly
 Figure 2-7 Winch Controller Wiring Diagram
 Figure 2-8 Winch Controller Wiring Diagram
 Figure 2-9 Remote Controller Electrical Schematic (M977, M985)
 Figure 2-10 Remote Controller Wiring Diagram (M977, M985)
 Figure 2-11 Tanker Component Identification
 Figure 2-12 Tanker Fuel System Functional Diagram
 Figure 2-13 Tanker Operation Functional Diagram
 Figure 2-14 Tanker Fuel System Schematic
 Figure 2-15 Wiring Diagram-Engine Heater Model CP3050A (24 Volt)
 Figure 2-16 Wiring Diagram-Personnel Heater Model AP3050-24FB
 Figure 2-17 STE/ICE Vehicle Test
 Figure 2-18 Relationship of GO, NO-GO Tests
 Figure 2-19 STE/ICE System
 Figure 2-20 VTM Controls and Readout Display
 Figure 2-21 Cable Assemblies
 Figure 2-22 Connector Key Location
 Figure 2-23 Transducer Kit
 Foldout 1 Electric Diagram
 Foldout 2 Air Schematic
 Foldout 3 Hydraulic Schematic
 TM 9-2320-279-10, Operator's Manual for M977 Series Vehicles
 LO 9-2320-279-12, Lubrication Order for M977 Series Vehicles
 FM 10-71, Petroleum Tank Vehicle Operations
 TM 9-6140-200-14, Operator's, Organizational, Direct Support, and General Support Maintenance Manual for Lead-Acid Storage Batteries
 TM 750-254, Cooling Systems: Tactical Vehicles
 TM 9-214, Inspection, Care and Maintenance of Antifriction Bearings
 FM 55-506-1, Basic Electricity
 DA Pamphlet 750-33, Charging System Troubleshooting

Troubleshooting Instructions (Cont)

Figure 2-2 shows location of all circuit breakers to be checked during troubleshooting. Refer to it often. Each circuit breaker is numbered on this illustration.

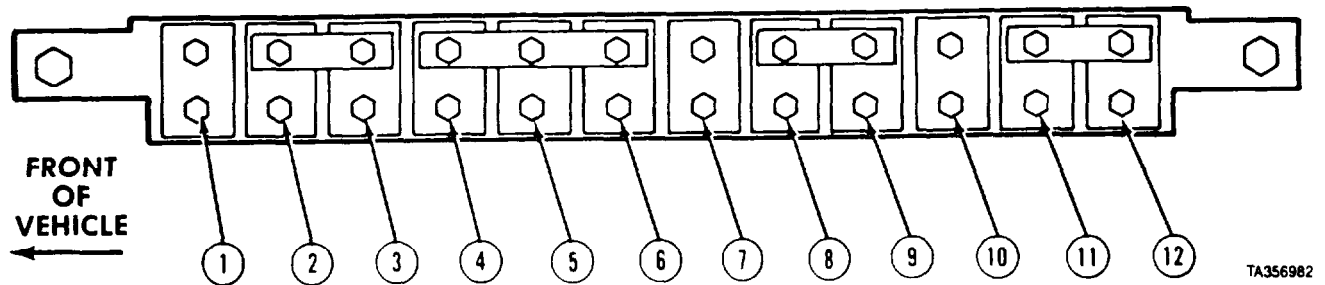


Figure 2-2. Circuit Breakers (Center Console).

Troubleshooting Index

Table 2-7. System Symptom index

| | Troubleshooting Procedure Page |
|---|--------------------------------------|
| AIR SYSTEM | |
| 1. Air pressure buildup slow | 2-134 |
| 2. Moisture in air system | 2-137 |
| 3. Compressor fails to unload | 2-137 |
| 4. Noisy compressor operation | 2-138 |
| 5. Compressor cycles constantly | 2-138 |
| 6. Air pressure drops rapidly after engine shutdown | 2-139 |
| 7. Compressor leaks oil or coolant | 2-139 |
| 8. Safety valve fails to release system pressure at 150 psi (1034 kPa) | 2-140 |
| 9. Air system pressure builds up to more than 130 psi (896 kPa) | 2-140 |
| 10. Left or right windshield wiper dots not work | 2-140 |
| 11. Windshield washer does not work | 2-141 |
| 12. Air horn does not work | 2-142 |
| 13. Axles will not lock up | 2-143 |
| 14. Transfer case will not lock up | 2-144 |
| 15. Throttle treadle accelerates engine but no air pressure in remainder of air system..... | 2-146 |
| ARCTIC HEATER KIT | |
| 1. Coolant pump fails to operate (indicator light does not come on) | 2-251 |
| Coolant pump fails to operate (indicator light comes on) | 2-253 |
| 3. Heat output to battery box too low | 2-254 |
| 4. Heater fails to sufficiently warm engine (coolant pump operating) | 2-255 |
| 5. Circuit breaker opens | 2-256 |
| DUAL AIR BRAKE SYSTEM | |
| Brakes will not respond properly..... | 2-162 |
| 2. Uneven braking | 2-166 |
| 3. Service brakes fail to release or release slowly | 2-168 |
| 4. Brakes grab when applied | 2-168 |
| 5. Pressure drops over 25 psi (172 kPa) at gage when brakes are applied | 2-169 |
| 6. Spring brakes will not apply | 2-169 |
| 7. Spring brakes will not release | 2-171 |

Troubleshooting Index (Cont)

2-15. TROUBLESHOOTING INSTRUCTIONS (CONT).

Table 2-7. System Symptom Index (Cont)

| | Troubleshooting Procedure Page |
|--|--------------------------------------|
| DUAL AIR BRAKE SYSTEM (CONT) | |
| 8. Brakesoverheat | 2-172 |
| 9. Front axle parking brakes will not apply (M984E1) | 2-173 |
| 10. Front axle parking brakes will not release (M984E1) | 2-174 |
| ELECTRICAL SYSTEM | |
| 1. Battery weak or fails to maintain charge | 2-114 |
| 2. Engine brake will not operate | 2-114.1 |
| 3. Heater fan motor will not operate | 2-115 |
| 4. Power take off (PTO) switch will not engage | 2-118 |
| 5. Light not working | 2-120 |
| 6. Dimmer switch fails to operate | 2-121 |
| 7. Stoplights do not work | 2-122 |
| 8. Air pressure warning light and buzzer do not work when air pressure drops below approximately 65 psi (448 kPa) | 2-123 |
| 9. Domelight does not work | 2-125 |
| 10. ENGINE STOP switch does not activate fuel shutdown solenoid | 2-126 |
| 11. Work light does not work | 2-126 |
| 11.1 Work lights fail to work (M984E1) | 2-127 |
| 12. Air dryer constantly exhausts air | 2-128 |
| 13. Marker and clearance lights do not work | 2-129 |
| 14. Ether starting aid does not work | 2-130 |
| 15. Electric gages do not work | 2-131 |
| 16. Switches do not work | 2-131 |
| 17. Trailer electrical system does not work | 2-132 |
| 18. Turn signals do not operate | 2-132 |
| 19. Oil-water indicator and buzzer do not work when oil pressure drops below 8psi(55kPa) | 2-13 4 |
| 20. Oil-water indicator and buzzer do not work when coolant temperature rises above 230°F(110° C) | 2-134.2 |
| ENGINE | |
| 1. Fails to crank | 2-59 |
| 2. Fails to develop full power/does not run smoothly | 2-63 |
| 3. Oil pressure low | 2-63 |
| 4. Overheats | 2-64 |
| 5. High oil consumption | 2-66 |
| 5.1 High crankcase pressure | 2-66 |
| 6. ENGINE HIGH IDLE does not operate (M977, M985) | 2-66 |
| 7. ENGINE HIGH IDLE does not operate (M983) | 2-70 |
| 8. Engine speed control does not operate (M978) | 2-74 |
| 9. ENGINE HIGH IDLE does not operate when craning M984, M985E1) | 2-78 |
| 9.1 ENGINE HIGH IDLE does not operate (M984E1) | 2-82 |
| 9.2 ENGINE HIGH IDLE does not operate when craning M984E1) | 2-89 |
| 10. ENGINE HIGH IDLE does not operate when using heavy-duty winch (M984) | 2-99 |
| 10.1 ENGINE HIGH IDLE does not operate when using heavy-duty winch in remote control (M984E1) | 2-103 |
| 10.2 ENGINE HIGH IDLE does not operate when using heavy-duty winch in manual control (M984E1) | 2-106 |
| 10.3 ENGINE HIGH IDLE does not operate when using retriever system (M984E1) | 2-110 |

Troubleshooting Index (Cont)
Table 2-7. System Symptom Index (Cont)

| | Troubleshooting Procedure Page |
|---|---|
| FIFTH WHEEL | |
| 1. Excessive movement of trailer kingpin in fifth wheel | 2-175 |
| FRONT AND REAR AXLE TANDEMS | |
| 1. Noisy drive axle | 2-156 |
| 2. Differential lock-up does not engage or disengage | 2-157 |
| FUEL SYSTEM | |
| 1. Engine will not start, or stalls | 2-111 |
| 2. Engine cranks but does not start when ether injector is actuated in cold weather. | 2-113 |
| 3. Fuel level gage does not register or registers inaccurately | 2-113 |
| HEAVY-DUTY WINCH | |
| 1. Winch cable will not pay out (M984) | 2-178 |
| 1.1 Winch cable will not pay out (M984E1) | 2-181 |
| 2. Winch will not rewind (M984) | 2-185 |
| 2.1 Winch will not rewind (M984E1) | 2-188 |
| 2.2 Winch will not operate in either direction | 2-192 |
| 3. Winch makes excessive or unusual noise (M984) | 2-192 |
| 4. Winch operation is jerky, slow, or does not work (M984) | 2-193 |
| 5. Fairlead/tensioner motor does not operate (M984E1) | 2-194 |
| HYDRAULIC SYSTEM | |
| 1. Winch retriever system or crane jerks when operated | 2-152 |
| 2. One or more hydraulic circuits not working | 2-153 |
| MATERIAL HANDLING CRANE (M983) | |
| 1. Crane does not function | 2-194 |
| 2. Crane boom moves slowly | 2-195 |
| 3. Outrigger cylinders will not retract | 2-196 |
| MATERIAL HANDLING CRANE (M977, M985, M984E1) | |
| 1. Crane will not operate. | 2-196 |
| 2. Outrigger operation slow or abnormal or outriggers will not extend or retract | 2-197 |
| 3. Mast raises or lowers abnormally, slowly, or will not raise or lower | 2-197 |
| 4. Boom operates abnormally, slowly, will not telescope in or out, or raise or lower | 2-198 |
| 5. Hoist will not lift or lower load | 2-200 |
| 6. Hoist operation slow or abnormal when lifting or lowering load | 2-201 |
| 7. Swing operation slow or abnormal in one or both directions | 2-203 |
| 8. Deleted | |
| 9. Crane controls sticking | 2-204 |
| 10. Remote controller will not operate crane or operates abnormally | 2-204 |
| PERSONNEL ARCTIC HEATER KIT - DELETED | |
| PROPELLER SHAFT AND UNIVERSAL JOINTS | |
| 1. Noisy or vibrating propeller shaft or U-joints. | 2-155 |
| RETRIEVER SYSTEM (M984E1) | |
| 1. Retriever system will not lift load, will not lower load, or will not center tow cylinders (M984E1). | 2-208 |

Troubleshooting Index (Cont)

2-15. TROUBLESHOOTING INSTRUCTIONS (CONT).

Table 2-7. System Symptom Index (Cont)

| | Troubleshooting Procedure Page |
|---|--------------------------------------|
| SELF-RECOVERY WINCH | |
| 1. Winch operation is jerky, slow, or does not work | 2-175 |
| 2. Excessive noise from winch | 2-177 |
| 3. Winch will not reverse | 2-178 |
| 4. Winch will not pull load | 2-178 |
| STEERING SYSTEM | |
| 1. Hard to steer | 2-147 |
| 2. Wanders or pulls to one side | 2-148 |
| 3. Sudden increase in effort to turn steering wheel | 2-150 |
| 4. Steering wheel does not turn fully in either direction | 2-152 |
| SUSPENSION (SHOCK ABSORBERS, SPRINGS, AND TORQUE RODS) | |
| 1. Vehicle wanders or shimmies | 2-160 |
| 2. Vehicle leans to one side, or rear sags | 2-161 |
| 3. Rear axle tandem out of line or not tracking properly | 2-161 |
| TANKER | |
| 1. DISCHARGE LINE PRESSURE GAGE (DLPG) or VENTURI/NOZZLE PRESSURE GAGE (VNPG) not working | 2-209 |
| 2. Fuel spills from vent when bottom loading with exterior pump | 2-225 |
| 3. Fuel flow does not stop within 15 seconds after opening V12 B/L PRECHECK VALVE when bottom loading. | 2-226 |
| 4. Cannot bottom load fuel | 2-228 |
| 5. AUXILIARY PUMP will not pump fuel | 2-230 |
| 6. Fuel servicing rate is slow or no flow | 2-235 |
| 7. Cannot evacuate fuel from hoses or primary pump stops or fails to deliver rated flow | 2-236 |
| 8. Primary pump makes excessive noise | 2-239 |
| 9. AUXILIARY PUMP fails to deliver rated flow | 2-240 |
| 10. AUXILIARY PUMP makes excessive noise | 2-240 |
| 11. TANK LEVEL INDICATOR gage does not register proper fuel level | 2-241 |
| 12. Deleted | |
| 13. Deleted | |
| TRANSFER CASE | |
| 1. Noisy transfer case | 2-154 |
| 2. Transfer does not shift into high or low, or slips out of gear | 2-155 |
| TRANSMISSION | |
| 1. Transmission oil temperature gage continuously reads over 250°F | 2-157 |
| 2. Transmission noisy | 2-159 |
| 3. Will not shift into gear, slips out of gear, or operates abnormally | 2-159 |
| WHEELS AND TIRES | |
| 1. Tires unevenly worn | 2-174 |

Troubleshooting Index (Cont)

Table 2-8. Troubleshooting Subject Index

| Subject | Vehicle System | Page |
|--|---|-------------|
| Air dryer constantly exhausts air | Electrical | 2-128 |
| Air horn does not work | Air | 2-142 |
| Air pressure buildup slow | Air | 2-134 |
| Air pressure drops rapidly after engine shutdown | Air | 2-139 |
| Air pressure warning light and buzzer do not work when air pressure drops below approximately 65 psi (448 kPa) | Electrical | 2-123 |
| Air system pressure builds up to more than 130 psi (896 kPa) | Air | 2-140 |
| AUXILIARY PUMP makes excessive noise | Tanker | 2-240 |
| AUXILIARY PUMP fails to deliver rated flow | Tanker | 2-240 |
| AUXILIARY PUMP will not pump fuel | Tanker | 2-230 |
| Axles will not lockup | Air | 2-143 |
| Battery weak or fails to maintain charge | Electrical | 2-114 |
| Boom operates abnormally, slowly, will not telescope in or out, or raise or lower | Material Handling Crane (M977, M985, M984E1) | 2-198 |
| Brakes grab when applied | Dual Air Brake | 2-168 |
| Brakes overheat | Dual Air Brake | 2-172 |
| Brakes will not respond properly | Dual Air Brake | 2-162 |
| Cannot bottom load fuel with tanker pump | Tanker | 2-228 |
| Cannot evacuate fuel from hoses or primary pump stops or fails to deliver rated flow | Tanker | 2-236 |
| Circuit breaker open | Arctic Heater Kit | 2-256 |
| Compressor cycles constantly | Air | 2-138 |
| Compressor fails to unload | Air | 2-137 |
| Compressor leaks oil or coolant | Air | 2-139 |
| Coolant pump fails to operate (indicator light comes on) | Arctic Heater Kit | 2-253 |
| Coolant pump fails to operate (indicator light does not come on) ... | Arctic Heater Kit | 2-251 |
| Crane boom moves slowly | Material Handling Crane (M983) | 2-195 |
| Crane controls sticking | Material Handling Crane (M977, M985, M984E1) | 2-204 |
| Crane does not function | Material Handling Crane (M983) | 2-194 |
| Crane will not operate | Material Handling Crane (M977, M985, M984E1) | 2-196 |
| Differential lock-up does not engage or disengage | Front and Rear Axle Tandems | 2-157 |
| Dimmer switch fails to operate | Electrical | 2-121 |
| DISCHARGE LINE PRESSURE GAGE (DLPG) or VENTURI/NOZZLE PRESSURE GAGE (VNPG) not working | Tanker | 2-209 |
| Domelight does not work | Electrical | 2-125 |
| Electric gages do not work | Electrical | 2-131 |
| Engine brake will not operate | Electrical | 2-114 |
| Engine cranks but does not start when ether injector is actuated in cold weather | Fuel | 2-113 |
| Engine fails to crank | Engine | 2-59 |
| ENGINE HIGH IDLE does not operate (M977, M985) | Engine | 2-66 |

Troubleshooting Index (Cont)

2-15. TROUBLESHOOTING INSTRUCTIONS (CONT).

Table 2-8. Troubleshooting Subject Index (Cont)

| Subject | Vehicle System | Page |
|---|---|-------|
| ENGINE HIGH IDLE does not operate (M983) | Engine | 2-70 |
| ENGINE HIGH IDLE does not operate when craning (M984, M985E1) | Engine | 2-78 |
| ENGINE HIGH IDLE does not operate (M984E1) | Engine | 2-82 |
| ENGINE HIGH IDLE does not operate when craning (M984E1) | Engine | 2-89 |
| ENGINE HIGH IDLE does not operate when using heavy-duty winch in manual control (M984E1) | Heavy-Duty Winch | 2-106 |
| ENGINE HIGH IDLE does not operate when using heavy-duty winch in remote control (M984E1) | Heavy-Duty Winch | 2-103 |
| ENGINE HIGH IDLE does not operate when using retriever system (M984E1) | Heavy-Duty Winch | 2-110 |
| ENGINE HIGH IDLE does not operate when using heavy-duty winch (M984) | Engine | 2-99 |
| Engine fails to develop full power/does not run smoothly | Engine | 2-63 |
| Engine speed control does not operate (M978) | Engine | 2-74 |
| ENGINE STOP switch does not activate fuel shutdown solenoid | Electrical | 2-126 |
| Engine will not start, or stalls | Fuel | 2-111 |
| Ether starting aid does not work | Electrical | 2-130 |
| Excessive movement of trailer kingpin in fifth wheel | Fifth Wheel | 2-175 |
| Excessive noise from winch | Self-Recovery Winch | 2-177 |
| Fairlead tensioner motor does not operate (M984E1) | Heavy-Duty Winch | 2-194 |
| Front axle parking brakes will not apply (M984E1) | Dual Air Brake | 2-173 |
| Front axle parking brakes will not release (M984E1) | Dual Air Brake | 2-174 |
| Fuel flow does not stop within 15 seconds after opening VI2 B/L PRECHECK VALVE when bottom loading with exterior pump | Tanker | 2-226 |
| Fuel level gage does not register or registers inaccurately | Fuel | 2-113 |
| Fuel servicing rate is slow or no flow | Tanker | 2-235 |
| Fuel spills from vent when bottom loading with exterior pump | Tanker | 2-225 |
| Hard to steer | Steering | 2-147 |
| Heater fails to sufficiently warm engine (coolant pump operating) | Arctic Heater Kit | 2-255 |
| Heater fan motor will not operate | Electrical | 2-115 |
| Heat output to battery box too low | Arctic Heater Kit | 2-254 |
| Highcrankcase pressure | Engine | 2-66 |
| High oil consumption | Engine | 2-66 |
| Hoist operation slow or abnormal when lifting or lowering load | Material Handling Crane (M977, M985, M984E1) | 2-201 |
| Hoist will not lift or lower load | Material Handling Crane (M977, M985, M984E1) | 2-200 |
| Left or right windshield wiper does not work | Air | 2-140 |
| Light not working | Electrical | 2-120 |
| Loss of fluid | Transmission | 2-154 |
| Marker and identification lights do not work | Electrical | 2-129 |
| Mast raises or lowers abnormally, slowly, or will not raise or lower | Material handling Crane (M977, M9851, M984E1) | 2-197 |
| Moisture in air system | Air | 2-137 |

Troubleshooting Index (Cont)

Table 2-8. Troubleshooting Subject Index (Con t)

| Subject | Vehicle System | Page |
|---|---|-------|
| Noisy compressor operation | Air | 2-138 |
| Noisy drive axle | Front and Rear Axle Tandems | 2-156 |
| Noisy or vibrating propeller shaft or U-joints | propeller shaft and Universal Joints | 2-155 |
| Noisy transfer case | Transfer Case | 2-124 |
| Oil leaks in case area | Transfer Case | 2-123 |
| Oil pressure low | Engine | 2-63 |
| One or more hydraulic circuits not working | Hydraulic | 2-153 |
| One or more lights not working (warning or service lights) | Electrical | 2-120 |
| Outrigger cylinder will not retract | Material Handling Crane (M983) | 2-196 |
| Outrigger operation slow or abnormal or outriggers will not extend or retract | Material Handling Crane (M977, M985, M984E1) | 2-197 |
| Overheats | Engine | 2-64 |
| Parking brakes will not apply at front axle (M984E1) | Dual Air Brake | 2-173 |
| Parking brakes will not release at front axle (M984E1) | Dual Air Brake | 2-174 |
| Power Takeoff Switch (PTO) will not engage | Electrical | 2-116 |
| Pressure build up slow | Air | 2-134 |
| Pressure drops over 25 psi at gage when brakes are applied | Dual Air Brake | 2-169 |
| Pressure drops rapidly after engine shutdown | Air | 2-139 |
| Primary pump makes excessive noise | Tanker | 2-239 |
| Rear axle tandem out of line or not tracking properly | Suspension | 2-161 |
| Remote controller will not operate crane or operates abnormally. | Material Handling Crane (M977, M985, M984E1) | 2-204 |
| Retriever system will not lift load, will not lower load, or will not center tow cylinders (M984E1) | Retriever | 2-208 |
| Safety valve fails to release system pressure at 150 psi (1 034 kPa) , | Air | 2-140 |
| Service brakes fail to release or release slowly | Dual Air Brake | 2-168 |
| Service lights not working | Electrical | 2-120 |
| Slips out of gear or operates abnormally | Transmission | 2-159 |
| Spring brakes will not apply | Dual Air Brake | 2-169 |
| Spring brakes will not release | Dual Air Brake | 2-171 |
| Steering wheel does not turn fully in either direction | Steering | 2-152 |
| Stoptlights do not work | Electrical | 2-122 |
| Sudden increase in effort to turn steering wheel | Steering | 2-150 |
| Swing operation slow or abnormal in one or both directions | Material Handling Crane (M977, M985, M984E1) | 2-203 |
| Switches do not work | Electrical | 2-131 |
| Throttle treadle accelerates engine but no air pressure in remainder of air system | Air | 2-146 |
| Tires unevenly worn | Wheels and Tires | 2-174 |
| Trailer electrical system does not work | Electrical | 2-132 |
| Transfer does not shift into high or low, or slips out of gear | Transfer Case | 2-155 |
| Transfer case will not lock up | Air | 2-144 |

Troubleshooting Index (Cont)

2-15. TROUBLESHOOTING INSTRUCTIONS (CONT).

Table 2-8. Troubleshooting Subject Index (Cont)

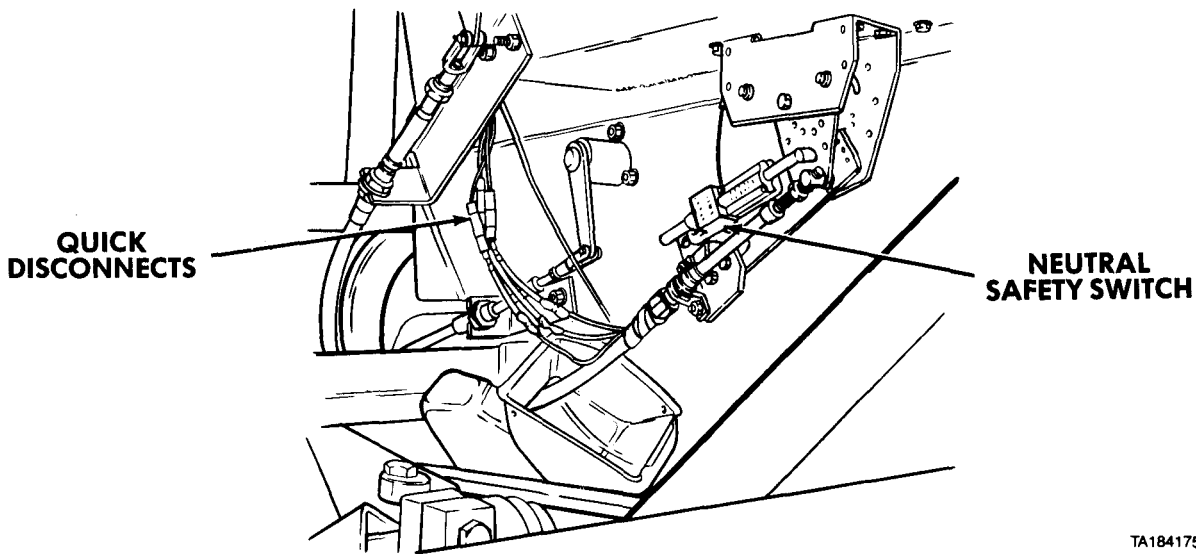
| Subject | Vehicle System | Page |
|---|---|-------------|
| Transmission noisy | Transmission | 2-159 |
| Transmission oil temperature gage continuously reads over 250°F . | Transmission | 2-157 |
| Turn signals do not operate | Electrical | 2-132 |
| Unevenbraking | Dual Air Brake | 2-166 |
| Vehicle leans to one side, or rear sags | Suspension | 2-161 |
| Vehicle wanders or shimmies | Suspension | 2-160 |
| Vibration of propeller shaft | Propeller Shaft and Universal Joints | 2-155 |
| Wanders or pulls to one side | Steering | 2-148 |
| Warning or service lights not working | Electrical | 2-120 |
| Will not shift into gear, slips out of gear, or operates abnormally ... | Transmission | 2-159 |
| Winch cable will not pay out (M984) | Heavy-Duty Winch | 2-178 |
| Winch cable will not pay out (M984El) | Heavy-Duty Winch | 2-181 |
| Winch makes excessive or unusual noise (M984) | Heavy-Duty Winch | 2-192 |
| Winch operation is jerky, slow, or does not work (M984) | Heavy-Duty Winch | 2-193 |
| Winch operation is jerky, slow, or does not work | Self-Recovery Winch | 2-175 |
| Winch or crane jerks when operated | Hydraulic | 2-152 |
| Winch will not operate in either direction (M984El) | Heavy-Duty Winch | 2-192 |
| Winch will not rewind | Heavy-Duty Winch | 2-185 |
| Winch will not rewind (M984El) | Heavy-Duty Winch | 2-188 |
| Winch will not pull load | Self-Recovery Winch | 2-178 |
| Winch will not reverse | Self-Recovery Winch | 2-178 |
| Windshield washer does not work | Air | 2-141 |
| Work light does not work.. | Electrical | 2-126 |
| Work lights fail to work (M984El) | Electrical | 2- 127 |

Troubleshooting Malfunctions (Cont)

Table 2-9. Troubleshooting (Cont)

| Malfunction | Test or Inspection | Corrective Action |
|---|--------------------|-------------------|
| ENGINE | | |
| 1. FAILS TO CRANK. | | |
| <p>Step 1. Check transmission range selector is in N (Neutral). Move transmission range selector to N.</p> | | |
| <p>Step 2. Check BATTERY gage reads 22-28 volts with ENGINE switch ON.</p> | | |
| | | |
| NOTE | | |
| <ul style="list-style-type: none"> · There are two types of batteries. Model A is identified by a 6TN printed on the side of the battery, while Model B has a 6TL printed on the side of the battery. · Refer to the illustrations for Models A and B for proper positioning of the batteries. The battery caps of Model B do not protrude through the bracket. · If Models A and B are combined on the same vehicle, all batteries will be positioned as shown for Model B. Tighten loose battery cable connections and clean corroded battery connections (TM 9-6140-200-14). Repair broken connections (FM 55-506-1). | | |
| <p>Step 3. Check voltage at batteries for 22-28 volts. If voltage is below 22 volts, service batteries.</p> | | |

Troubleshooting Malfunctions (Cont)
Table 2-9. Troubleshooting (Cont)

| Malfunction | Test or Inspection | Corrective Action |
|---|--------------------|---|
| ENGINE (CONT) | | |
| 1. FAILS TO CRANK (CONT). | | |
|  | | |
| | | TA184175 |
| | Step 4. | Slide rubber boot back and check neutral safety switch for visible damage. Replace damaged neutral safety switch (para 8-4). |
| | Step 5. | Check neutral safety switch quick disconnects for looseness or damage. Tighten or repair quick disconnects as necessary. |
| | Step 6. | Check neutral safety switch for 22-28 volts at input terminal with ENGINE switch to START. If there is voltage, go to Step 12. |

Troubleshooting Malfunctions (Cont)

Table 2-9. Troubleshooting (Cont)

| Malfunction | Test or Inspection | Corrective Action |
|-------------------------------|--|-------------------|
| ENGINE (CONT) | | |
| FAILS TO CRANK (CONT). | | |
| | | |
| Step 7. | Check ENGINE START switch for loose or damaged connections. Tighten loose connections or repair damaged connections. | |
| Step 8. | Check ENGINE START switch for 22-28 volts at BAT terminal with ENGINE switch OFF. If no voltage, check circuit breaker No. 5 (step 10). | |
| Step 9. | Check output side of circuit breaker No. 5 for 22-28 volts (fig. 2-2). If voltage is 22-28 volts, harness is bad. Notify the supervisor. | |
| Step 10. | Check input side of circuit breaker No. 5 for 22-28 volts (fig. 2-2). If voltage is 22-28 volts, replace circuit breaker 5 (para 7-43). | |
| Step 11. | Check ENGINE START switch for 22-28 volts at ST terminal with ENGINE START switch to START. If no voltage, replace ENGINE START switch (para 7-37). | |
| Step 12. | Check neutral safety switch adjustment. Replace neutral safety switch if not working or cannot be adjusted (para 8-4). | |

Troubleshooting Malfunctions (Cont)

2-15. TROUBLESHOOTING INSTRUCTIONS (CONT).

Table 2-9. Troubleshooting (Cont)

| Malfunction | Test or Inspection | Corrective Action |
|--|--------------------|---|
| ENGINE (CONT) | | |
| FAILS TO CRANK (CONT). | | |
| <p>The diagram shows a cross-section of an engine compartment. On the left, a hand is shown testing a wire labeled 'CHECK FOR VOLTAGE'. In the center, the starter motor is connected to a 'STARTER RELAY'. Wires are labeled: 'INPUT TERMINAL WIRE NO. 46' (connected to the relay), 'WIRE NO. 21' (connected to the relay), and 'OUTPUT TERMINAL' (connected to the starter motor). A hand is also shown testing the 'INPUT TERMINAL WIRE NO. 46'.</p> | | |
| | Step 13. | Check at starter relay for 22-28 volts with ENGINE switch to START. If no voltage, repair wire No. 021 that runs from starter relay to ENGINE START switch. Refer to FO-1, Electric Diagram. |
| | Step 14. | Check starter relay INPUT terminal for 22-28 volts with ENGINE switch OFF. If no voltage, check starter wire No. 46 for continuity. Refer to FO-1, Electric Diagram. |
| | Step 15. | Check starter relay OUTPUT terminal for 22-28 volts with ENGINE switch to START. If no voltage, replace starter relay (para 7-94). |
| | Step 16. | Check starter for loose or damaged connections. Tighten loose connections. Replace damaged connections. |
| | Step 17. | Test starter motor (para 7-7). If results are bad, replace starter motor (para 7-8). |
| | Step 18. | If engine still fails to crank, notify the supervisor. |
| | 2 | FAILS TO DEVELOP FULL POWER/DOES NOT RUN SMOOTHLY. |
| | Step 1. | Check air restriction indicator. If red, reset. Start engine and check again. If still red, service air cleaner (TM 9-2320-279-10). |
| | Step 2. | Check fuel water separator for contamination or damage. Service or replace as required (paras 4-9 and 4-10). |

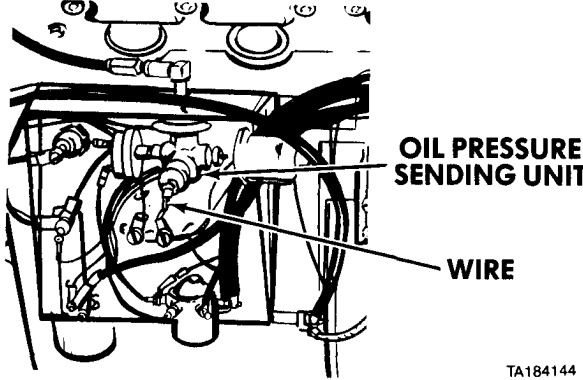
Troubleshooting Malfunctions (Cont)

2-15. TROUBLESHOOTING INSTRUCTIONS (CONT).

Table 2-9. Troubleshooting (Cont)

| Malfunction | Test or Inspection | Corrective Action |
|---|---|--|
| ENGINE (CONT) | | |
| 2. FAILS TO DEVELOP FULL POWER/DOES NOT RUN SMOOTHLY (CONT). | | |
| | Step 3. Inspect secondary fuel filter for leaks or damage. | Tighten or replace secondary fuel filter (para 4-11). |
| | Step 4. Inspect fuel lines and connections for leaks or damage. | Tighten or replace as required (para 4-6). |
| | Step 5. Test throttle treadle valve (para 4-13). | Replace defective throttle treadle valve (para 4-14). |
| | Step 6. If problem has not been solved, notify the supervisor. | |
| 3. OIL PRESSURE LOW. | | |
| | Step 1. Check engine oil level on dipstick (LO 9-2320-279-12). | Add oil as required (LO 9-2320-279-12). |
| | | |
| | Step 2. Check oil filter and oil lines for leaks or damage. | Tighten or replace oil filter (para 3-4). Tighten connections. |
| | | If lines are damaged, notify the supervisor. |

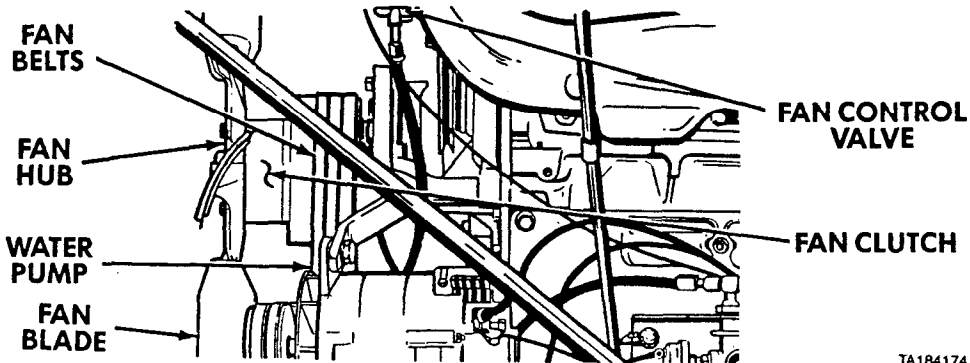
Troubleshooting Malfunctions (Cont)
Table 2-9. Troubleshooting (Cont)

| Malfunction | Test or Inspection | Corrective Action |
|------------------------------------|---|--|
| ENGINE (CONT) | | |
| 3. OIL PRESSURE LOW (CONT). | | |
| | Step 3. Inspect engine for oil leaks. | Tighten loose screws if any components are leaking oil. Check and add oil as required (LO 9-2320-279-12). Replace rocker cover or gasket if leaking (para 3-3). |
| | Step 4. Check oil pressure gage and warning light circuits for continuity. Refer to FO-1, Electric Diagram. | Replace broken wires and connectors. |
| |  | |
| | | TA184144 |
| | Step 5. Test oil pressure sending unit and oil pressure gage. | Remove wire from oil pressure sending unit and touch to ground. If oil pressure gage shows high pressure, replace sending unit (para 7-79). If oil pressure gage shows no pressure, replace oil pressure gage (para 7-20). |
| | Step 6. If problem has not been solved, notify the supervisor. | |
| 4. OVERHEATS. | | |
| | Step 1. When radiator cools down, remove radiator cap and check coolant level. | If coolant level is low, service cooling system (para 6-2). |
| | Step 2. Inspect coolant hoses for damage or loose clamps. | If clamps are loose, tighten, then service cooling system (para 6-2). If coolant hose is damaged, replace damaged hose (para 6-7). |

Troubleshooting Malfunctions (Cont)

2-15. TROUBLESHOOTING INSTRUCTIONS (CONT).

Table 2-9. Troubleshooting (Cont)

| Malfunction | Test or Inspection | Corrective Action |
|-----------------------------|---|---|
| ENGINE (CONT) | | |
| 4. OVERHEATS (CONT). | | |
| | Step 3. Inspect radiator for leaks or damage. | If radiator is leaking or damaged, replace radiator (para 6-3). |
| | Step 4. Check if fan belts are loose, damaged or missing (refer to para 6-17 for allowable looseness). | If loose, adjust fan belts (para 6-16). If damaged or missing, replace fan belts (para 6-17). |
| | Step 5. Check radiator cooling fins for dirt, mud, or debris. | If fins are clogged, clear radiator fins. |
| | Step 6. Inspect water pump for leaks. | If there are no leaks, go to Step 7. If leaking, notify the supervisor. |
| |  | |
| | Step 7. Inspect fan hub and blades for damage. | If damaged, replace fan (para 6-11). |
| | NOTE | |
| | Engine temperature must be approximately 195 °F (91 °C) and air pressure between 100 and 120 psi (690 and 827 kPa) before fan control valve can be checked. | |
| | Step 8. Check fan control valve for proper operation. Remove hose from fan clutch to fan control valve. | If air comes out of fan control valve fitting, replace fan control valve (para 6-10). If air does not come out of fan control valve fitting, replace fan clutch (para 6-12). |

TA184174

Troubleshooting Malfunctions (Cont)

2-15. TROUBLESHOOTING INSTRUCTIONS (CONT).

Table 2-9. Troubleshooting (Cont)

| Malfunction Test or Inspection | Corrective Action |
|---|--|
| ENGINE (CONT) | |
| 4. OVERHEATS (CONT). | |
| Step 9. | Check thermostats. Remove thermostats (para 6-8 or 6-9). Test thermostats (TM 750-254). Replace defective thermostat (para 6-8 or 6-9). |
| Step 10. | If still overheating, notify the supervisor. |
| 5. HIGH OIL CONSUMPTION. | |
| NOTE | |
| If engine uses less than 10 qt (9 L) of oil in 1000 mi (1 609 K) of operation, oil consumption is normal. | |
| Step 1. | Check oil filter, oil lines, engine covers, and oil pan for oil leaks, Tighten leaking connections and covers and tighten or replace oil filter as necessary (para 3-4). Add oil as required (LO 9-2320-279-12). |
| Step 2. | Check water temperature gage for engine overheating. If engine is overheating, refer to MALFUNCTION 4, OVERHEATS. |
| Step 3. | If high oil consumption continues, notify the supervisor. |
| Step 4. | Check crankcase pressure. Place manometer (57333-6) on vehicle so that meter is visible during test. Remove oil dipstick and place hose (58639-2) of manometer at dipstick tube. Open bleeder valve on manometer to level out manometer fluid. Adjust manometer so that zero is placed along top portion of fluid line. Start engine and check crankcase pressure. Crankcase pressure shall be 3.1 in. of water at 1800 rpm, 3.3 in. at 1950 rpm, and 3.5 in. at 2100 rpm. If crankcase pressure is high, refer to MALFUNCTION 5.1 HIGH CRANKCASE PRESSURE. |
| 5.1. HIGH CRANKCASE PRESSURE, | |
| Step 1. | Check engine oil breather for clogged element, obstruction, or damage (para 3-3). Replace oil breather element, remove obstruction, or replace damaged parts (para 3-3). |
| Step 2. | Check muffler and exhaust system for obstruction or damage (para 5-2). Remove obstruction or replace damaged part (para 5-2). |

Troubleshooting Malfunctions (Cont)

Tab/e 2-9. Troubleshooting (Cont)

| Malfunction | Test or Inspection | Corrective Action |
|--|--|---|
| ENGINE (CONT) | | |
| ENGINE HIGH IDLE DOES NOT OPERATE (M977, M985). | | |
| | | |
| Step 1. | Check for defective engine speed control wiring. Disconnect plug from engine high idle assembly. Set multimeter to test for 24 Set Set ENGINE and PTO ENGAGE switches to ON and crane POWER switch to OFF. Place negative (-) probe in socket No. 4 and touch positive (+) probe to PIN No. 1. Meter should show 24 vdc. | If meter does not show 24 vdc, trace wiring and find problem. Refer to FO-1, Electric Diagram. |
| Step 2. | Check for defective crane power wiring. Disconnect plug from engine high idle assembly, Set multimeter to test for 24 vdc. Set crane POWER switch to ON. Place negative (-) probe in socket No. 4 and positive (+) probe to PIN No. 2. Meter should show 24 vdc. | If meter does not show 24 vdc, repair No. 310 wire to crane junction box. If problem is not solved, report problem to the supervisor. |

Troubleshooting Malfunctions (Cont)

2-15. TROUBLESHOOTING INSTRUCTIONS (CONT).

Table 2-9. Troubleshooting (Cont)

| Malfunction | Test or Inspection | Corrective Action |
|--|---|---|
| ENGINE (CONT) | | |
| 6. ENGINE HIGH IDLE DOES NOT OPERATE (M977, M985) (CONT). | | |
| <p style="text-align: right; font-size: small;">TA357227</p> | | |
| | <p>Step 3. Check for defective LATCH switch. Remove wires from LATCH switch. Hold switch in LATCH position and check continuity between terminals No. 1 and No. 2.</p> | <p>If resistance is more than zero ohms, replace defective LATCH switch (para 7-10).</p> |
| | <p>Step 4. Check for defective ENGINE HIGH IDLE control assembly ON/OFF switch. Remove wires from ON/OFF switch. Set switch to ON position. Check continuity between terminals No. 1 and No. 2.</p> | <p>If resistance is more than zero ohms, replace defective ON/OFF switch (para 7-10).</p> |

Troubleshooting Malfunctions (Cont)
Table 2-9. Troubleshooting (Cont)

| Malfunction | Test or Inspection | Corrective Action |
|---|--------------------|-------------------|
| ENGINE (CONT) | | |
| 6. ENGINE HIGH IDLE DOES NOT OPERATE (M977, M985) (CONT). | | |
| | | |
| <p>Step 5. Check for defective relay wiring. Remove cover from high idle box assembly. Check all wires for continuity.</p> <p style="padding-left: 40px;">If continuity is not found on all wires, repair connectors and replace wires as needed.</p> <p>Step 6. Check for defective relay No. 1. Disconnect connector from relay No. 1. Attach ground wire to terminal 86 and apply 24 vdc to terminal 85. Listen for clicking sound as relay is energized.</p> <p style="padding-left: 40px;">If relay does not click, replace relay (para 7-10).</p> <p>Step 7. Check for defective relay No. 2. Disconnect connector from relay No. 2. Attach ground wire to terminal 86 and apply 24 vdc to terminal 85. Listen for clicking sound as relay is energized.</p> <p style="padding-left: 40px;">If relay does not click, replace relay (para 7-10).</p> | | |

Troubleshooting Malfunctions (Cont)

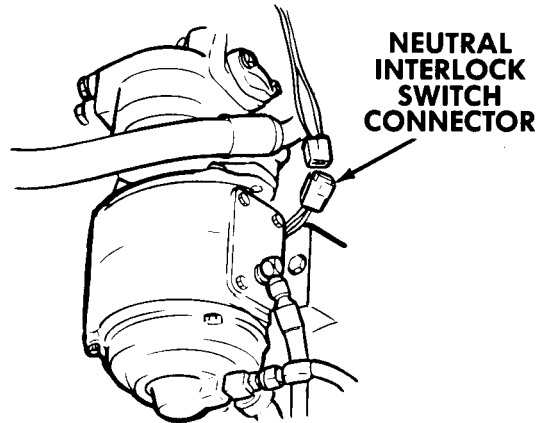
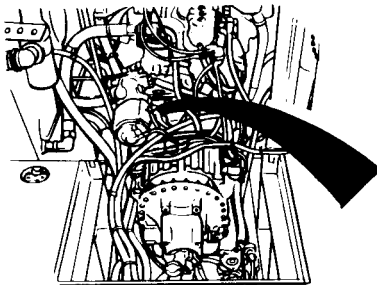
2-15. TROUBLESHOOTING INSTRUCTIONS (CONT).

Table 2-9. Troubleshooting (Cont)

| Malfunction | Test or Inspection | Corrective Action |
|-------------|--------------------|-------------------|
|-------------|--------------------|-------------------|

ENGINE (CONT)

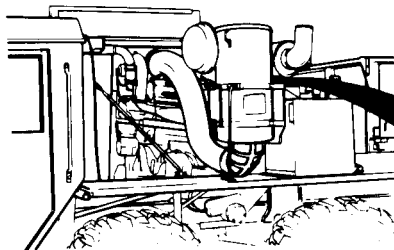
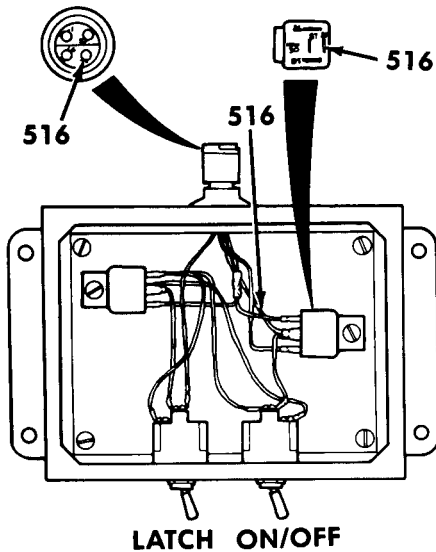
6. ENGINE HIGH IDLE DOES NOT OPERATE (M977, M985) (CONT).



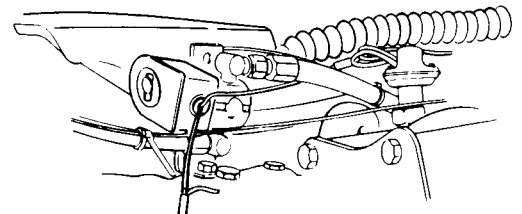
TA357226

Step 8. Check for defective neutral interlock switch. Disconnect neutral interlock switch connector on transmission. Place transmission in neutral. Check continuity between two terminals on neutral interlock switch connector.

If resistance is more than zero ohms, replace neutral interlock switch (para 7-97).

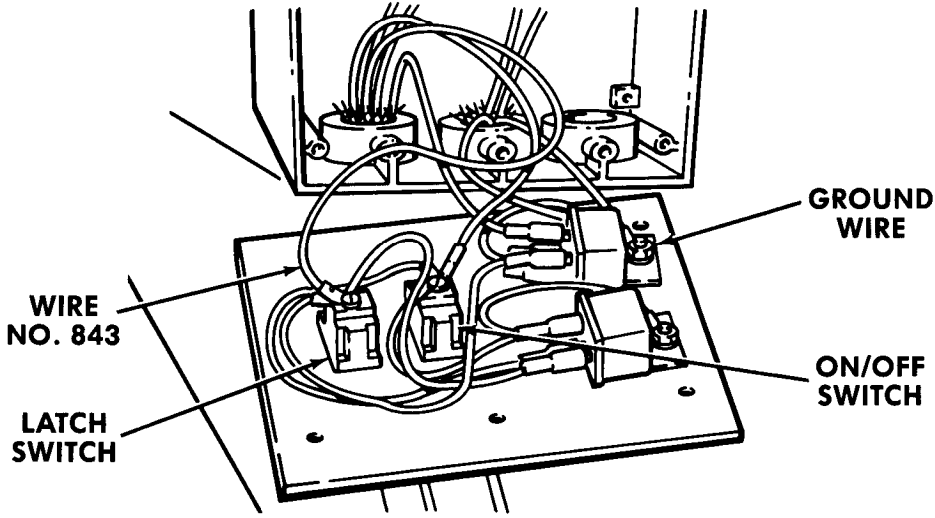


THROTTLE CONTROL SOLENOID LOCATED FORWARD OF MUFFLER



TA357245

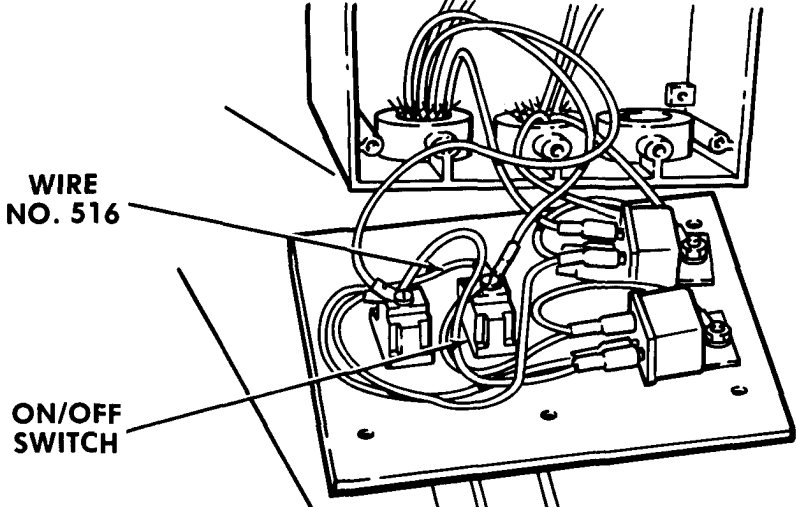
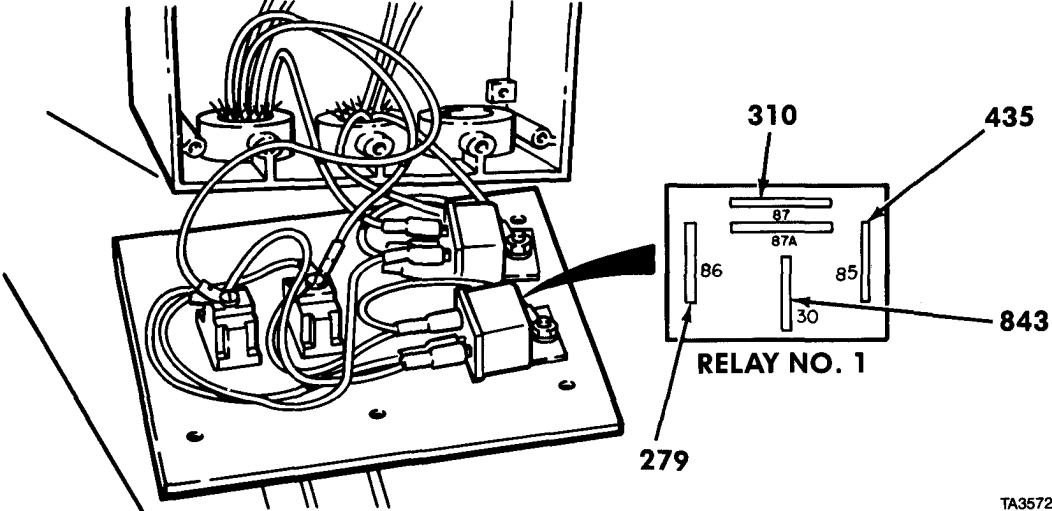
Troubleshooting Malfunctions (Cont)
Table 2-9. Troubleshooting (Cont)

| Malfunction | Test or Inspection | Corrective Action |
|---|--------------------|-------------------|
| ENGINE (CONT) | | |
| 6. ENGINE HIGH IDLE DOES NOT OPERATE (M977, M985) (CONT). | | |
| NOTE | | |
| Batteries must be disconnected (para 7-91). Connect batteries after any fault has been found and corrected. | | |
| Step 9. Check for defective wire 516 from throttle control solenoid butt connector to relay No. 2 (Refer to FO-1, Electric Diagram). Open HIGH IDLE box cover. Test wire resistance. | | |
| If resistance is more than zero ohms, repair wire or replace connector. | | |
| Step 10. Check for damaged or loose air line between throttle control solenoid and air governor. | | |
| Tighten loose connections, replace damaged air line. | | |
| If problem is not solved, report problem to the supervisor. | | |
| 7. ENGINE HIGH IDLE DOES NOT OPERATE (M983). | | |
|  | | |
| TA357223 | | |
| Step 1. Check for defective HIGH IDLE power wiring. Remove cover from HIGH IDLE assembly. Set multimeter to test for 24 vdc. Set engine and PTO ENGAGE switches to ON. Place negative (-) probe on ground wire on cover and touch positive (+) probe to center contact on latch switch. Meter should show 24 vdc. | | |
| If meter does not show 24 vdc, trace wiring and find problem. Refer to FO-1, Electric Diagram. | | |
| Step 2. Check for defective LATCH switch. Remove wires from latch switch. Hold switch in LATCH position and check continuity between terminals No. 1 and No. 2. | | |
| If resistance is more than zero ohms, replace defective LATCH switch (para 7-10). | | |

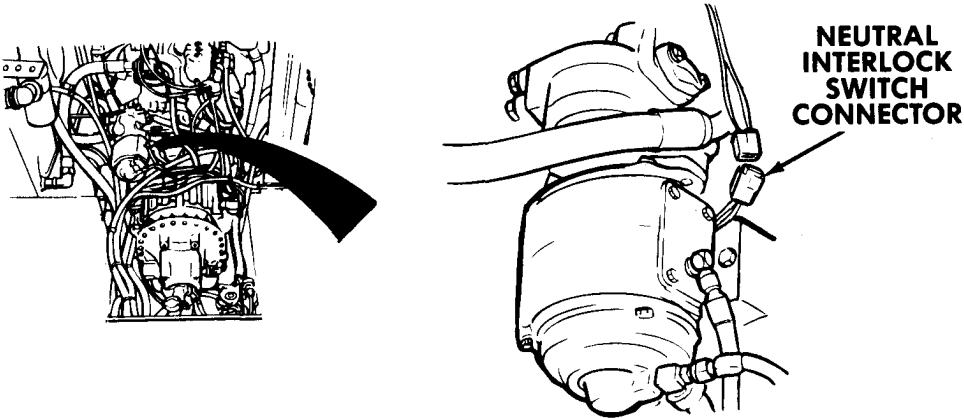
Troubleshooting Malfunctions (Cont)

2-15. TROUBLESHOOTING INSTRUCTIONS (CONT).

Table 2-9. Troubleshooting (Cont)

| Malfunction | Test or Inspection | Corrective Action |
|--|--------------------|-------------------|
| ENGINE (CONT) | | |
| 7. HIGH IDLE DOES NOT OPERATE (M983) (CONT). | | |
|  <p>A technical diagram of an engine control assembly. It shows a control panel with various electrical components. A specific wire is labeled 'WIRE NO. 516' and is connected to a component labeled 'ON/OFF SWITCH'. The diagram shows the internal wiring and the physical layout of the components on the panel.</p> | | |
| TA357224 | | |
| <p>Step 3. Check for defective ENGINE HIGH IDLE control assembly ON/OFF switch. Remove wires from ON/OFF switch. Set switch to ON position. Check continuity between terminals No. 1 and No. 2.</p> | | |
| <p style="padding-left: 40px;">If resistance is more than zero ohms, replace defective ON/OFF switch (para 7-10).</p> | | |
| <p>Step 4. Check for defective jumper wire No. 516. Check resistance of jumper wire No. 516.</p> | | |
| <p style="padding-left: 40px;">If resistance is more than zero ohms, repair wire or replace connector.</p> | | |
|  <p>A technical diagram of an engine control assembly, similar to the one above. It shows a control panel with various electrical components. A specific relay is labeled 'RELAY NO. 1'. The diagram shows the internal wiring and the physical layout of the components on the panel. Labels include '310', '435', '86', '87', '87A', '85', '30', '279', and '843'.</p> | | |
| TA357225 | | |

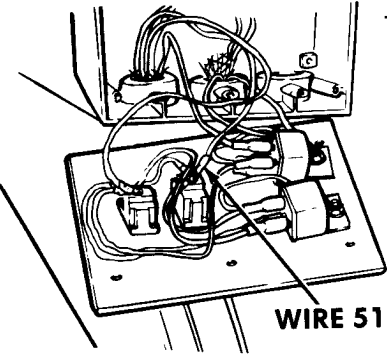
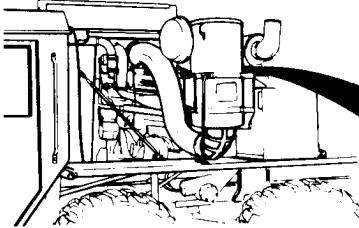
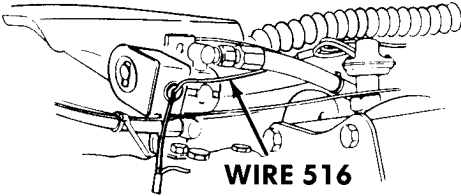
Troubleshooting Malfunctions (Cont)
Table 2-9. Troubleshooting (Cont)

| Malfunction | Test or Inspection | Corrective Action |
|---|---|---|
| ENGINE (CONT) | | |
| 7. HIGH IDLE DOES NOT OPERATE (M983) (CONT). | | |
| | Step 5. Check for defective relay No. 1 wiring. Check resistance of wires 310, 843, 279, and 435. | If resistance is more than zero ohms in any wire, repair wire or replace connector. |
| | Step 6. Check for defective relay No. 1. Remove wires from relay No. 1. Attach ground wire to terminal 85 and apply 24 vdc to terminal 86. Listen for clicking sound as relay is energized. | If relay does not click, replace relay (para 7-10). |
| |  | TA357226 |
| | Step 7. Check for defective neutral interlock switch. Disconnect neutral interlock switch connector on transmission. Place transmission in neutral. Check continuity between two terminals on neutral interlock switch connector. | If resistance is more than zero ohms, replace neutral interlock switch (para 7-97). |

Troubleshooting Malfunctions (Cont)

2-15. TROUBLESHOOTING INSTRUCTIONS (CONT).

Table 2-9. Troubleshooting (Cont)

| Malfunction | Test or Inspection | Corrective Action |
|---|---|--|
| ENGINE (CONT) | | |
| 7. HIGH IDLE DOES NOT OPERATE (M983) (CONT). | | |
|  |  | <p>THROTTLE CONTROL SOLENOID LOCATED FORWARD OF MUFFLER</p> |
|  | WIRE 516 | TA357254 |
| NOTE | | |
| <p>Batteries must be disconnected (para 7-91). Connect batteries after any fault has been found and corrected.</p> | | |
| <p>Step 8. Check for defective wire 516 from throttle control solenoid butt connector to ON/OFF power switch center terminal. Open HIGH IDLE box cover. Test wire resistance.</p> | | |
| <p>If resistance is more than zero ohms, repair wire or replace connector.</p> | | |
| <p>Step 9. Check for damaged or loose air line between throttle control solenoid and air governor.</p> | | |
| <p>Tighten loose connections, replace damaged air line.</p> | | |
| <p>If problem is not solved, notify the supervisor.</p> | | |

Troubleshooting Malfunctions (Cont)
Table 2-9. Troubleshooting (Cont)

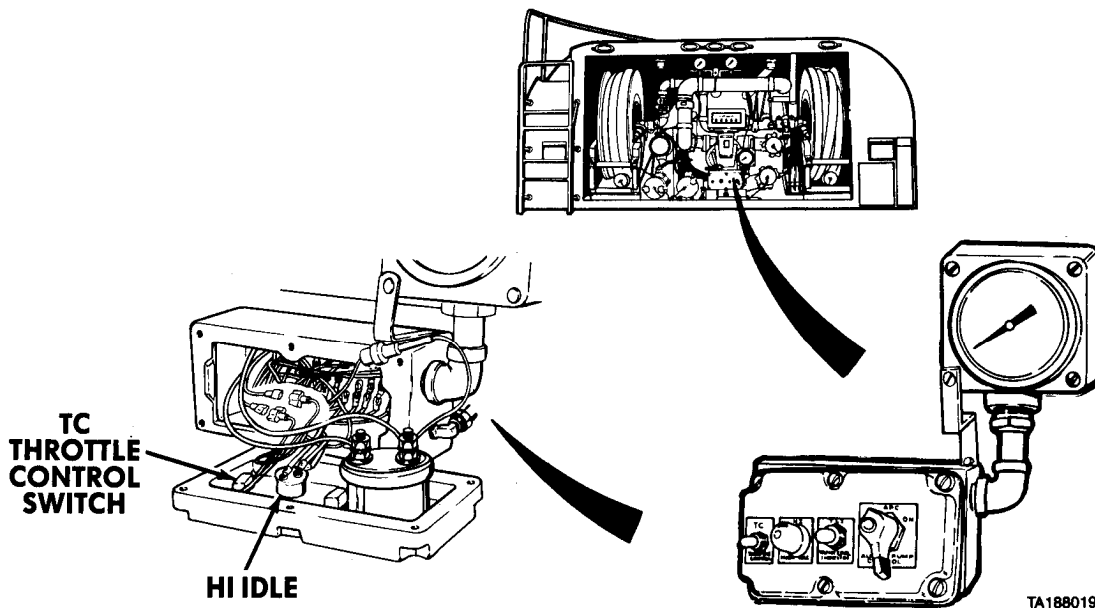
| Malfunction |
|--------------------|
| Test or Inspection |
| Corrective Action |

ENGINE (CONT)

8. ENGINE SPEED CONTROL DOES NOT OPERATE (M978).

WARNING

Before starting any troubleshooting on the M978 tanker, be sure to read and follow all safety precautions in FM 10-71, Petroleum Tank Vehicle Operations, and TM 9-2320-279-10, Operate tanker. Liquids and vapors carried in the M978 tanker are flammable and toxic and can cause injury or death.



NOTE

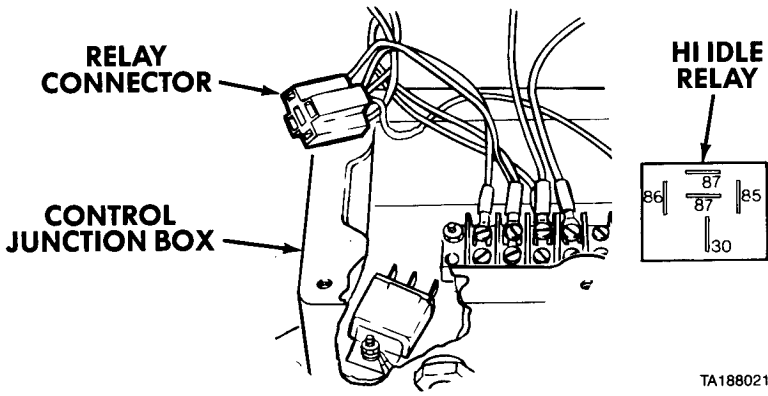
Refer to FO-1, Sheets 4 and 5, for M978 Tanker Electric Diagram.

- Step 1.** Check for defective TC THROTTLE CONTROL switch. Remove control junction box cover (para 7-49). Disconnect switch wires from connectors. Check switch resistance when toggle switch is set to ON.
- If resistance is zero ohms, connect wire, go to Step 2.
 - If resistance is more than zero ohms, replace switch (para 7-49).
- Step 2.** Check for defective HI HIGH IDLE contact button. Check resistance across switch terminals while contact button is depressed.
- If resistance is zero ohms, go to Step 3.
 - If resistance is more than zero ohms, replace contact button (para 7-49).

Troubleshooting Malfunctions (Cont)

2-15. TROUBLESHOOTING INSTRUCTIONS (CONT).

Table 2-9. Troubleshooting (Cont)

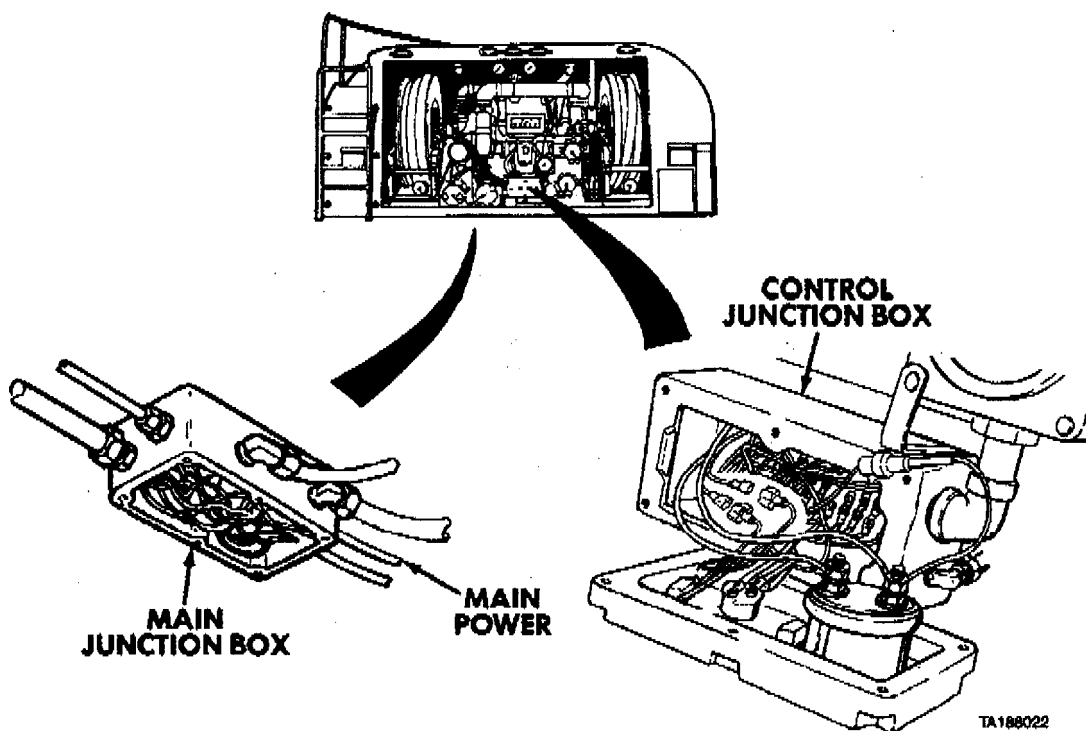
| Malfunction | Test or Inspection | Corrective Action |
|--|---|--|
| ENGINE (CONT) | | |
| 8. ENGINE SPEED CONTROL DOES NOT OPERATE (M978) (CONT). | | |
|  <p style="text-align: right; margin-right: 50px;">TA188021</p> | | |
| | <p>Step 3. Check for defective high idle relay. Disconnect connector from high idle relay. Attach ground wire to terminal No. 86 and apply 24vdc to terminal No. 85. Listen for clicking sound as high idle relay is energized.</p> | <p style="padding-left: 40px;">If high idle relay clicks, go to Step 4. Replace if high idle relay does not click, (para 7-49).</p> |
| | <p>Step 4. Check for defective high idle relay connector wiring. Check resistance of each wire from high idle relay connector to wire terminal and throttle control switch wire connector.</p> | <p style="padding-left: 40px;">If resistance is zero ohms, connect connector and go to Step 5. If resistance is more than zero ohms in any wire, repair wire or replace connector.</p> |

Troubleshooting Malfunctions (Cont)
Table 2-9. Troubleshooting (Cont)

Malfunction

Test or inspection

Corrective Action

ENGINE (CONT)**8. ENGINE SPEED CONTROL DOES NOT OPERATE (M978) (CONT).**

Step 5. Check for defective throttle control wiring. Remove main junction box cover (para 7-47), Check resistance of green wire between control junction box terminal board terminal No. 2 and main junction box terminal board terminal No. 2. Refer to FO-1, Electric Diagram, sheets 4 and 5.

If resistance is zero ohms, go to Step 6,

If resistance is more than zero ohms, repair or replace wire (pm-as 7-49 or 7-47).

Step 6. Check for defective tanker wiring. Disconnect main power connector. Check resistance of green wire between main junction box terminal board No. 2 and connector pin No. 2. Refer to FO-1, Electric Diagram, sheets 4 and 5, wire No. 516.

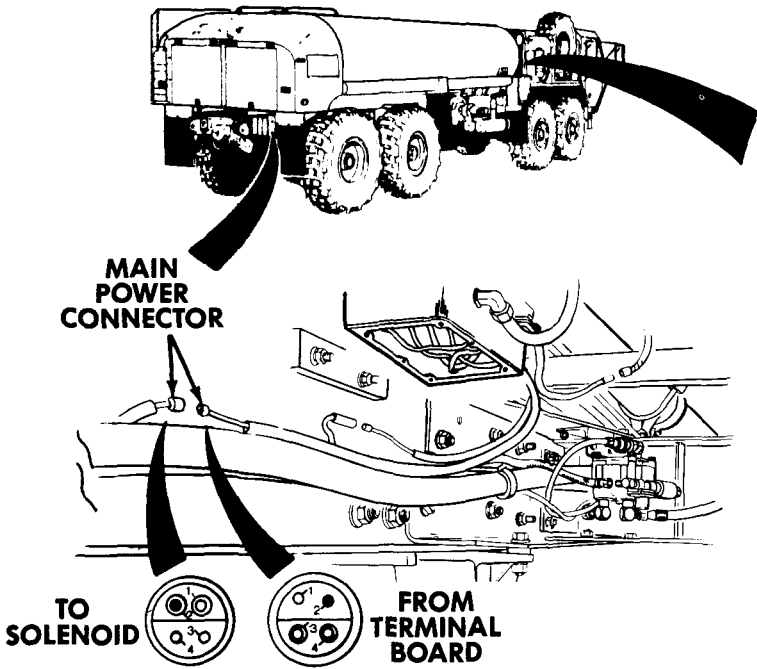
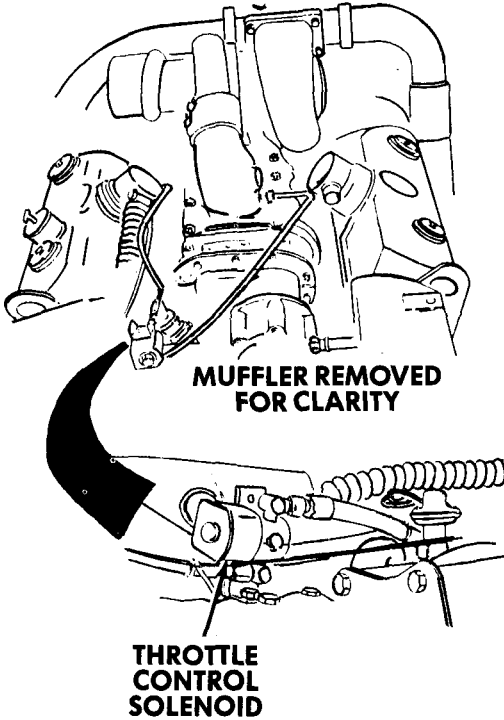
If resistance is zero ohms, go to Step 7.

If resistance is more than zero ohms, repair or replace green wire (para 7-47).

Troubleshooting Malfunctions (Cont)

2-15. TROUBLESHOOTING INSTRUCTIONS (CONT).

Table 2-9. Troubleshooting (Cont)

| Malfunction | Test or Inspection | Corrective Action |
|---|--|-------------------|
| ENGINE (CONT) | | |
| 8. ENGINE SPEED CONTROL DOES NOT OPERATE (M978) (CONT). | | |
|  <p>MAIN POWER CONNECTOR</p> <p>TO SOLENOID</p> <p>FROM TERMINAL BOARD</p> |  <p>MUFFLER REMOVED FOR CLARITY</p> <p>THROTTLE CONTROL SOLENOID</p> | <p>TA188023</p> |
| <p>Step 7. Check for defective throttle control solenoid wiring. Check resistance of wire between main power connector socket No. 2 and throttle control solenoid. Refer to FO-1, Electric Diagram, sheets 4 and 5, wire No. 516.</p> | | |
| <p style="padding-left: 40px;">If resistance is more than zero ohms, repair wire.</p> | | |
| <p style="padding-left: 40px;">If resistance is zero ohms, notify the supervisor.</p> | | |

Troubleshooting Malfunctions (Cont)
Table 2-9. Troubleshooting (Cont)

| Malfunction | Test or Inspection | Corrective Action |
|--|--------------------|-------------------|
| ENGINE (CONT) | | |
| 9. ENGINE HIGH IDLE DOES NOT OPERATE WHEN CRANING (M984, M985E1). | | |
| NOTE | | |
| <ul style="list-style-type: none"> • ENGINE HIGH IDLE will not operate unless air pressure is 65 to 75 psi (447 to 515 kPa) or more. If air pressure cannot be built up, go to AIR SYSTEM Troubleshooting. • Engine high idle speed is governed to 1500 rpm on M985E1 and 900 rpm on M984. • If front ENGINE HIGH IDLE control assembly does not operate, disconnect batteries (para 7-91), start with Step 4. • Refer to Figures 2-3 and 2-4 for HIGH IDLE Wiring Diagrams. | | |
| <p>The diagram illustrates the air supply system for the engine high idle. On the left, an 'AIR HOSE' is connected to a 'HI IDLE SOLENOID'. A thick black arrow points from the solenoid towards the engine governor, indicating that air should flow from the solenoid to the engine. The engine governor is shown as a large, ribbed component.</p> | | |
| TA188024 | | |
| NOTE | | |
| Air should exhaust from solenoid, not airhose. | | |
| Step 1. Check for defective airhose. | | |
| <p>(a). (M985E1) Check if airhose between solenoid and engine governor exhausts air when ENGINE and PTO ENGAGE switches are set to ON and ENGINE HIGH IDLE LATCH switch is operated.</p> | | |
| Replace airhose if it exhausts air. | | |

Troubleshooting Malfunctions (Cont)

2-15. TROUBLESHOOTING INSTRUCTIONS (CONT).

Table 2-9. Troubleshooting (Cont)

| Malfunction | Test or Inspection | Corrective Action |
|--|--------------------|-------------------|
| ENGINE (CONT) | | |
| 9. ENGINE HIGH IDLE DOES NOT OPERATE WHEN CRANING (M984, M985E1) (CONT). | | |
| | | |
| NOTE | | |
| Air should exhaust from pressure regulator. | | |
| <p>(b). (M984) Check if air hose between pressure regulator and air governor exhausts air when ENGINE and PTO ENGAGE switches are set to ON and ENGINE HIGH IDLE LATCH switch is operated.</p> | | |
| Replace air hose if it exhausts air. | | |

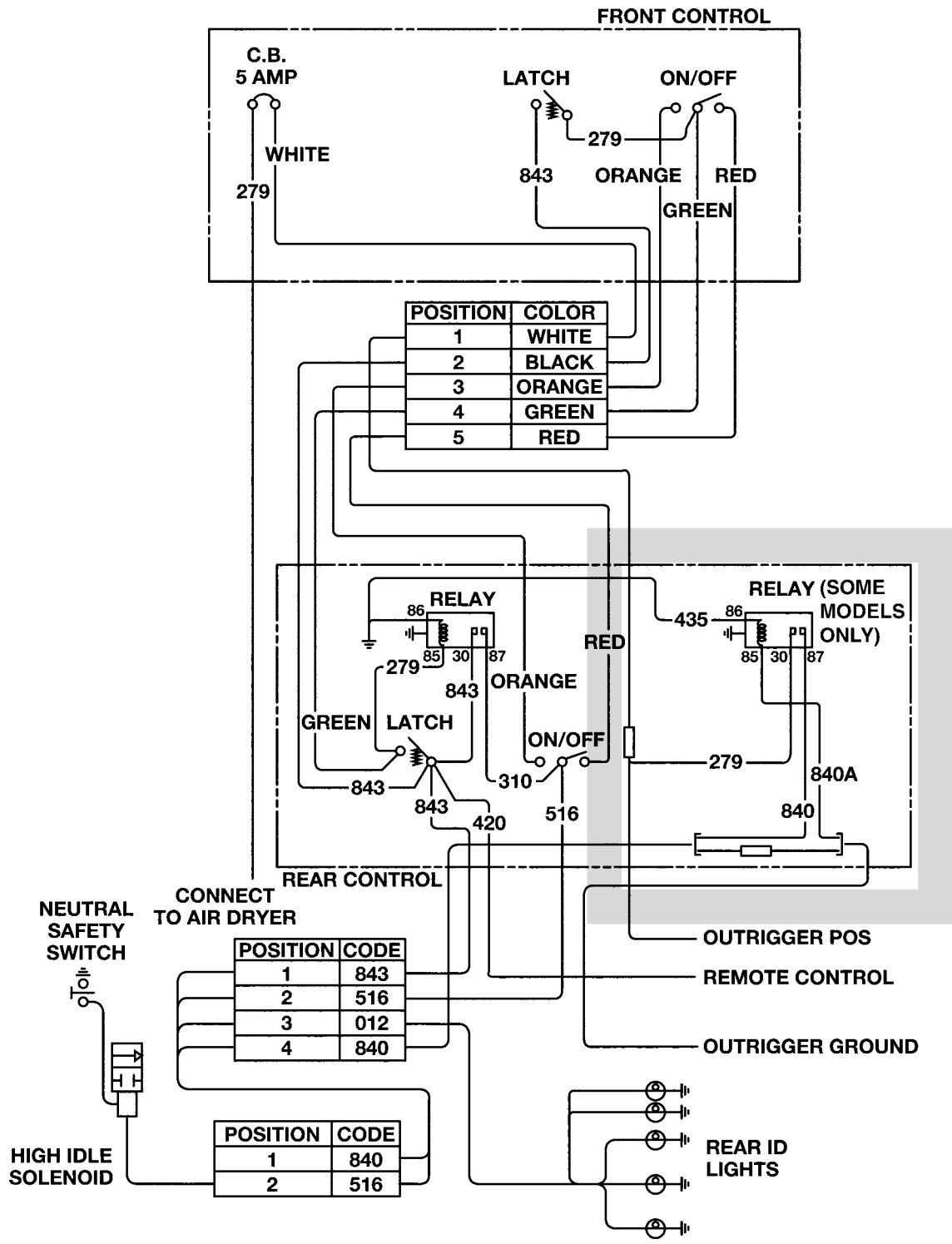
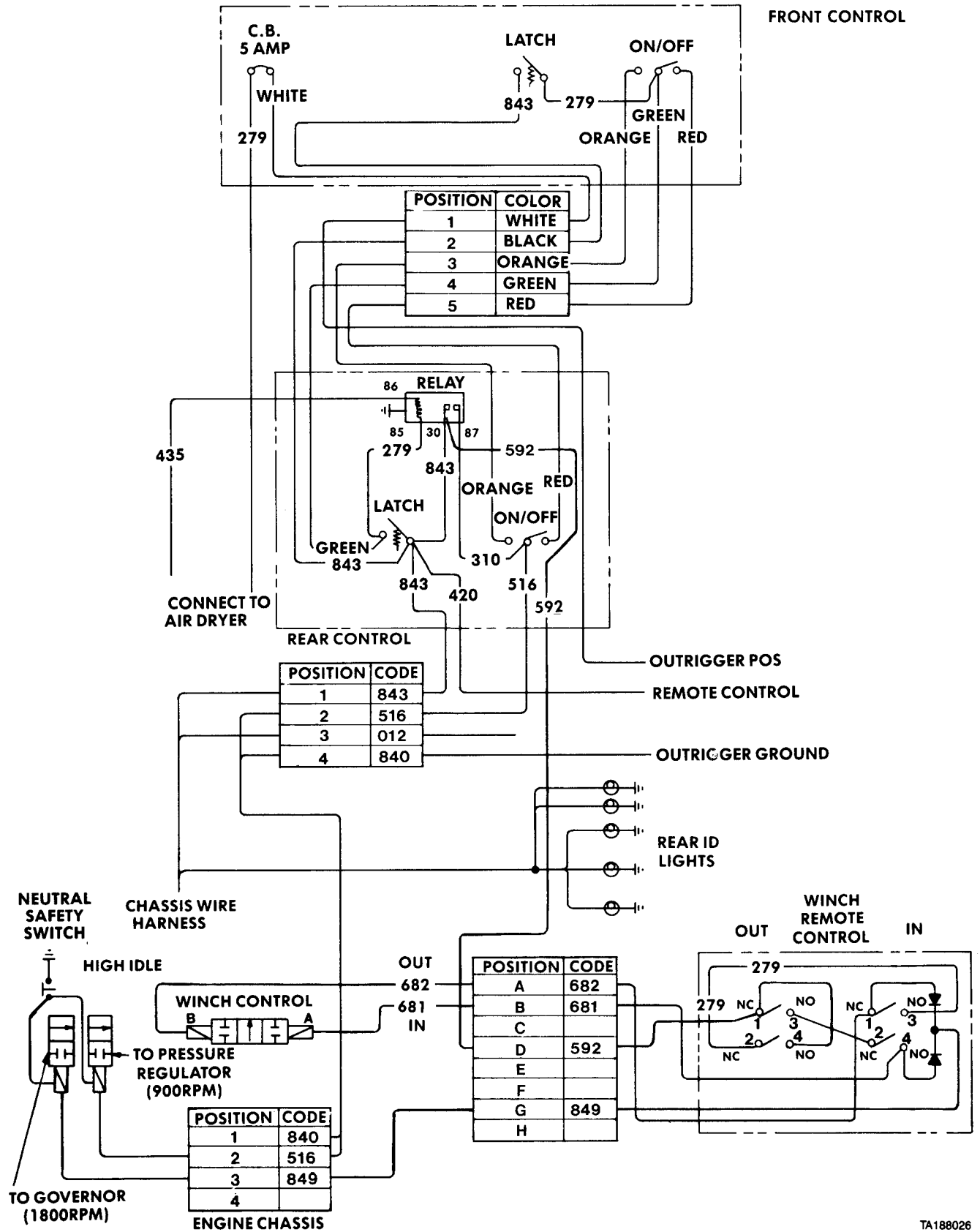


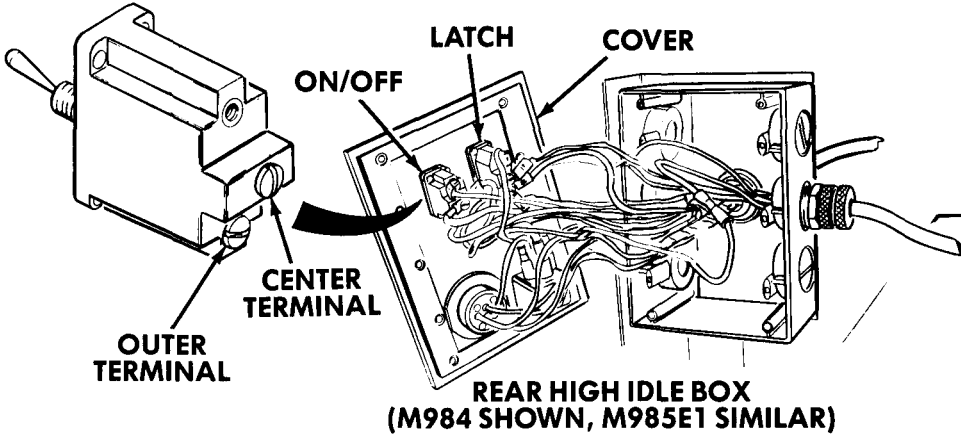
Figure 2-3. M985E1 HIGH IDLE Wiring Diagram



TA188026

Figure 2-4. M984 HIGH IDLE Wiring Diagram.

Troubleshooting Malfunctions (Cont)
Table 2-9. Troubleshooting (Cont)

| Malfunction | Test or Inspection | Corrective Action |
|---|--------------------|-------------------|
| ENGINE (CONT) | | |
| 9. ENGINE HIGH IDLE DOES NOT OPERATE WHEN CRANING (M984, M985E1) (CONT). | | |
|  | | |
| TA188028 | | |
| NOTE | | |
| Batteries must be disconnected (para 7-91). Connect batteries after any fault has been found and corrected. | | |
| Step 2. Remove rear ENGINE HIGH IDLE control assembly cover. Check for defective ENGINE HIGH IDLE LATCH switch. Disconnect wires from outer terminal. Test resistance between switch terminals when LATCH switch is operated. | | |
| If resistance is more than zero ohms, replace LATCH switch (para 7-11). | | |
| Step 3. Check for defective ENGINE HIGH IDLE control ON/OFF switch. Disconnect wires from center terminal. Test resistance between center and outer switch terminals. Place positive (+) probe on center terminal and negative (-) probe on outer terminals. With toggle in up position, resistance on bottom terminal should be zero ohms. With toggle in down position, resistance on top terminal should be zero ohms. | | |
| If resistance is more than zero ohms with either test, replace ON/OFF switch (para 7-11). | | |

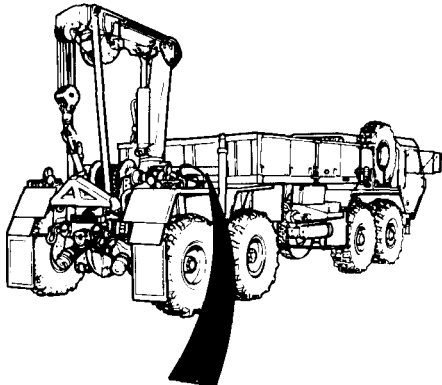
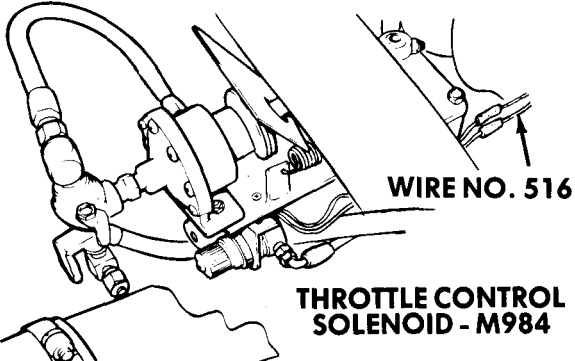
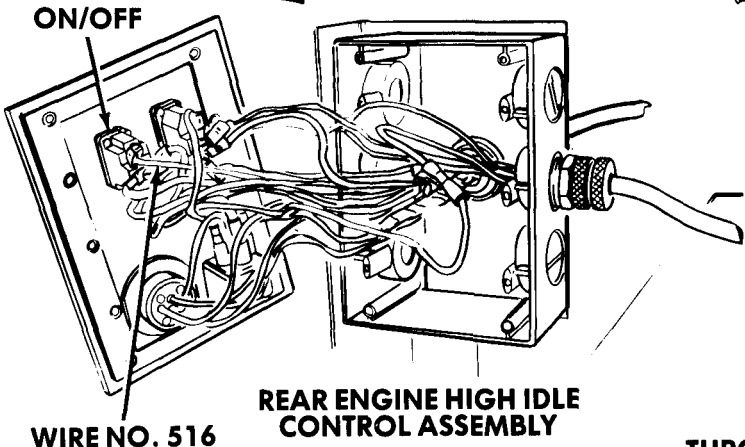
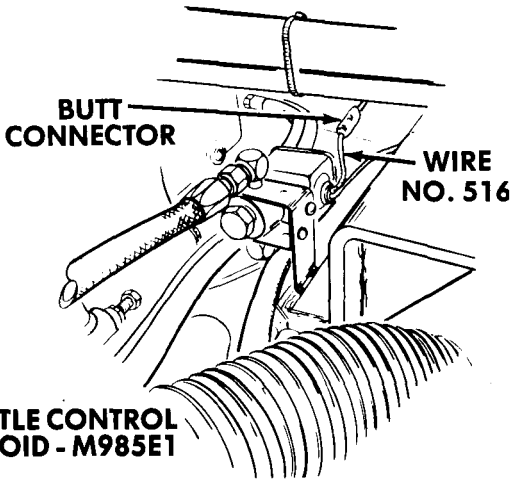
Troubleshooting Malfunctions (Cont)

2-15. TROUBLESHOOTING INSTRUCTIONS (CONT).

Table 2-9. Troubleshooting (Cont)

| Malfunction | Test or Inspection | Corrective Action |
|--|--|-------------------|
| ENGINE (CONT) | | |
| 9. ENGINE HIGH IDLE DOES NOT OPERATE WHEN CRANING (M984, M985E1) (CONT). | | |
| <p>Step 4. Check for defective neutral interlock switch. Disconnect neutral interlock switch connector on transmission. Test wire resistance when transmission set to neutral.</p> | <p>If resistance is more than zero ohms, replace neutral interlock switch sender unit (para 7-97).</p> | <p>TA188029</p> |

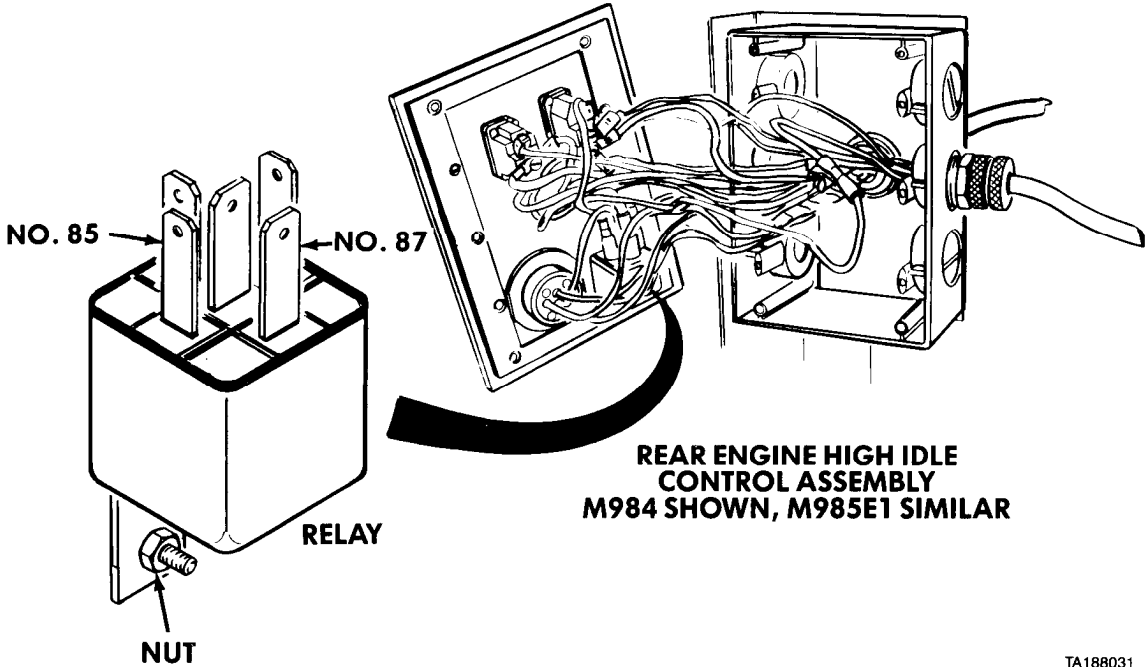
Troubleshooting Malfunctions (Cont)
Table 2-9. Troubleshooting (Cont)

| Malfunction | Test or Inspection | Corrective Action |
|--|---|-------------------|
| ENGINE (CONT) | | |
| 9. ENGINE HIGH IDLE DOES NOT OPERATE WHEN CRANING (M984, M985E1) (CONT). | | |
|  |  <p>WIRE NO. 516</p> <p>THROTTLE CONTROL SOLENOID - M984</p> | |
|  <p>ON/OFF</p> <p>WIRE NO. 516</p> <p>REAR ENGINE HIGH IDLE CONTROL ASSEMBLY</p> |  <p>BUTT CONNECTOR</p> <p>WIRE NO. 516</p> <p>THROTTLE CONTROL SOLENOID - M985E1</p> | |
| (M984 SHOWN, M985E1 SIMILAR) | | |
| TA188030 | | |
| <p>Step 5. Check for defective wire No. 516 from HIGH IDLE box to butt connector on solenoid wire. Test wire resistance.</p> | | |
| <p>If resistance is more than zero ohms, replace wire.</p> | | |

Troubleshooting Malfunctions (Cont)

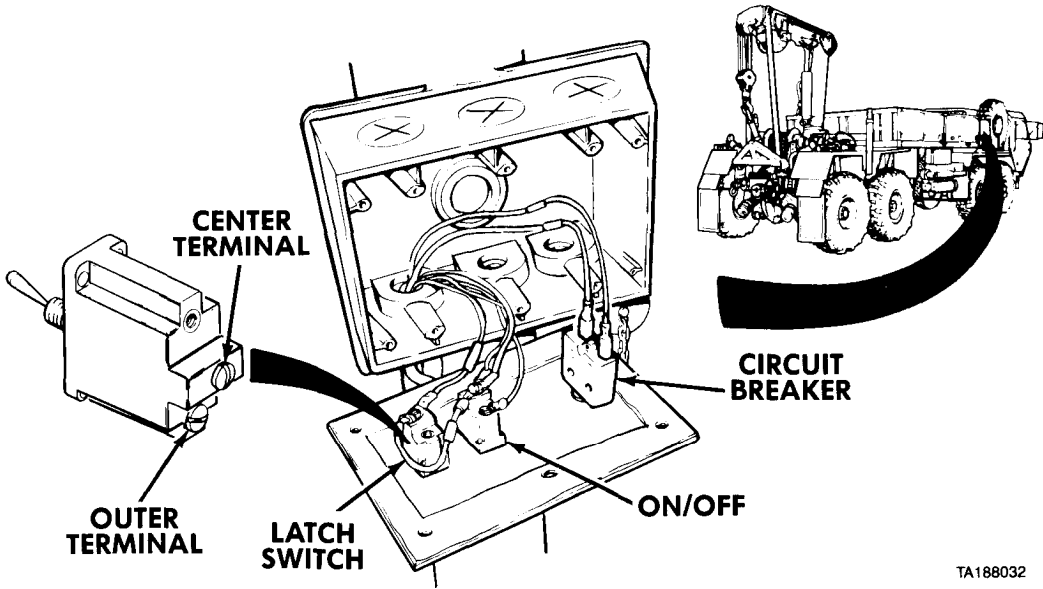
2-15. TROUBLESHOOTING INSTRUCTIONS (CONT).

Table 2-9. Troubleshooting (Cont)

| Malfunction | Test or Inspection | Corrective Action |
|---|--------------------|-------------------|
| ENGINE (CONT) | | |
| 9. ENGINE HIGH IDLE DOES NOT OPERATE WHEN CRANING (M984, M985E1) (CONT). | | |
|  <p style="text-align: center;">REAR ENGINE HIGH IDLE CONTROL ASSEMBLY M984 SHOWN, M985E1 SIMILAR</p> | | |
| <p>Step 6. Check for defective relay. Connect batteries (para 7-91). Test for 24 to 28 vdc relay voltage. Place positive (+) probe on relay terminal No. 85 or No. 87 and negative (-) probe on nut on relay. Set ENGINE and PTO ENGAGE switches to ON. Operate LATCH switch.</p> <p style="padding-left: 40px;">If no voltage is shown, replace relay (para 7-11).</p> | | |

TA188031

Troubleshooting Malfunctions (Cont)
Table 2-9. Troubleshooting (Cont)

| Malfunction Test or Inspection | Corrective Action |
|---|-------------------|
| ENGINE (CONT) | |
| 9. ENGINE HIGH IDLE DOES NOT OPERATE WHEN CRANING (M984, M985E1) (CONT). | |
|  | |
| NOTE | |
| Circuit breaker in front ENGINE HIGH IDLE control box (tire davit mounted) is not related to engine high idle operation. Circuit breaker is in crane control circuits. | |
| <p>Step 7. Remove front ENGINE HIGH IDLE control assembly cover. Check for defective front ENGINE HIGH IDLE control LATCH switch. Set multimeter to OHMS X1K. Disconnect wires from outer terminal. Test resistance between switch terminals when LATCH switch is operated.</p> <p style="padding-left: 40px;">If resistance is more than zero ohms, replace LATCH switch (para 7-12).</p> | |
| <p>Step 8. Check for defective ENGINE HIGH IDLE control ON/OFF switch. Disconnect wires from center terminal. Test resistance between center and outer switch terminals. Place positive (+) probe on center terminal and negative (-) probe on outer terminals. With toggle in up position, resistance on bottom terminal should be zero ohms. With toggle in down position, resistance on top terminal should be zero ohms.</p> <p style="padding-left: 40px;">If resistance is more than zero ohms with either test, replace ON/OFF switch (para 7-12).</p> | |

Troubleshooting Malfunctions (Cont)

2-15. TROUBLESHOOTING INSTRUCTIONS (CONT).

Table 2-9. Troubleshooting (Cont)

| Malfunction | Test or Inspection | Corrective Action |
|---|--------------------|-------------------|
| ENGINE (CONT) | | |
| 9. ENGINE HIGH IDLE DOES NOT OPERATE WHEN CRANING (M984, M985E1) (CONT). | | |
| <p>Step 9. Check for defective wiring between front ENGINE HIGH IDLE control assembly LATCH and ON/OFF switches and rear ENGINE HIGH IDLE control assembly. Disconnect red, orange and green wires, and wire No. 843. Refer to Figure 2-5 or 2-6. Test resistance of each wire.</p> | | |
| <p style="padding-left: 40px;">If resistance on any wire is more than zero ohms, repair or replace wire (paras 7-11 and 7-12).</p> | | |
| <p style="padding-left: 40px;">If problem remains, notify the supervisor.</p> | | |
| | | |
| Figure 2-5. M984 HIGH IDLE Control Assembly. | | |

TA188033

Troubleshooting Malfunctions (Cont)
Table 2-9. Troubleshooting (Cont)

| Malfunction | Test or Inspection | Corrective Action |
|-------------|--------------------|-------------------|
|-------------|--------------------|-------------------|

ENGINE (CONT)

9. ENGINE HIGH IDLE DOES NOT OPERATE WHEN CRANING (M984, M985E1) (CONT).

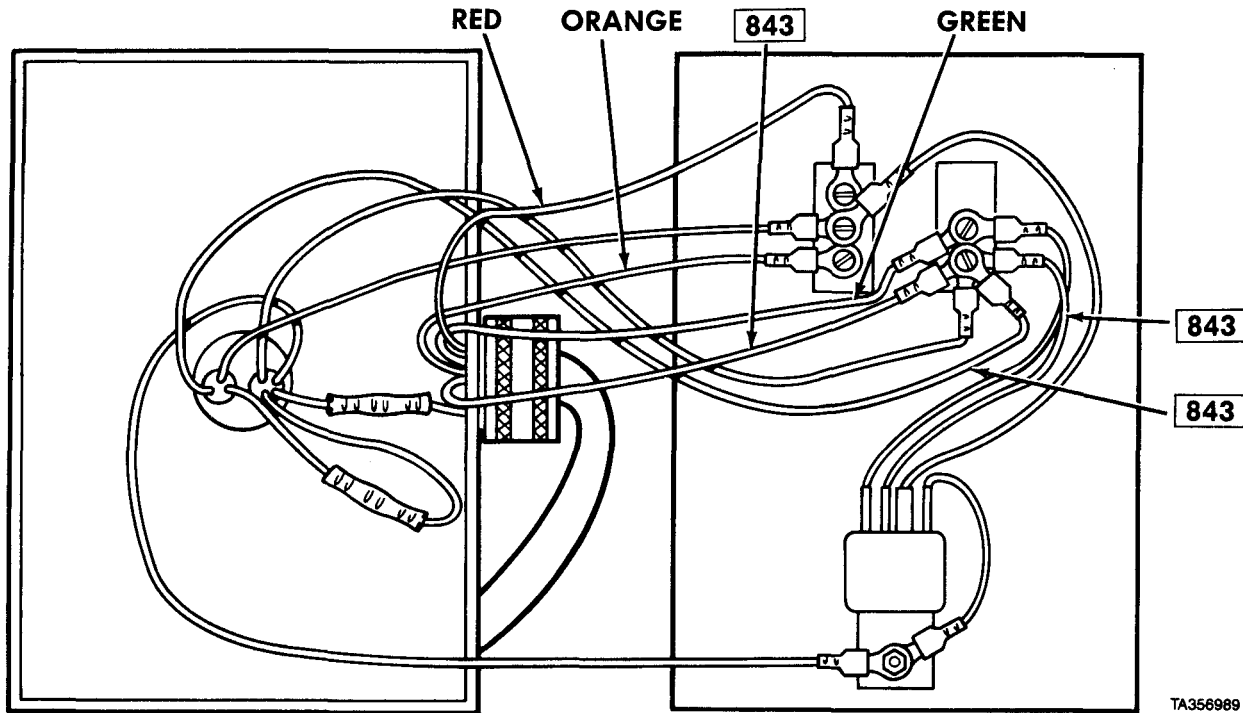
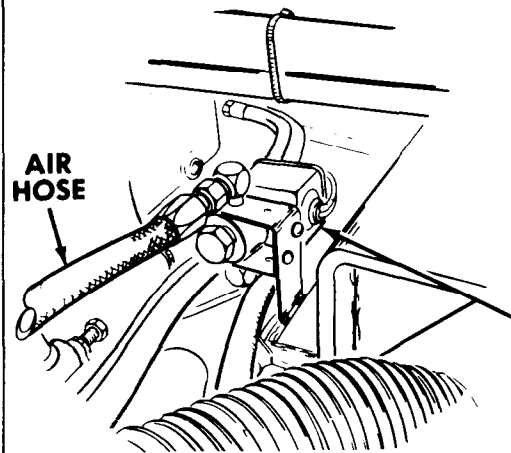
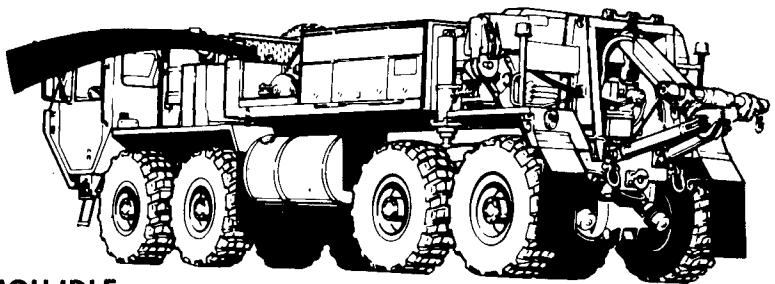


Figure 2-6. M985E1 HIGH IDLE Control Assembly.

Troubleshooting Malfunctions (Cont)

2-15. TROUBLESHOOTING INSTRUCTIONS (CONT).

Table 2-9. Troubleshooting (Cont)

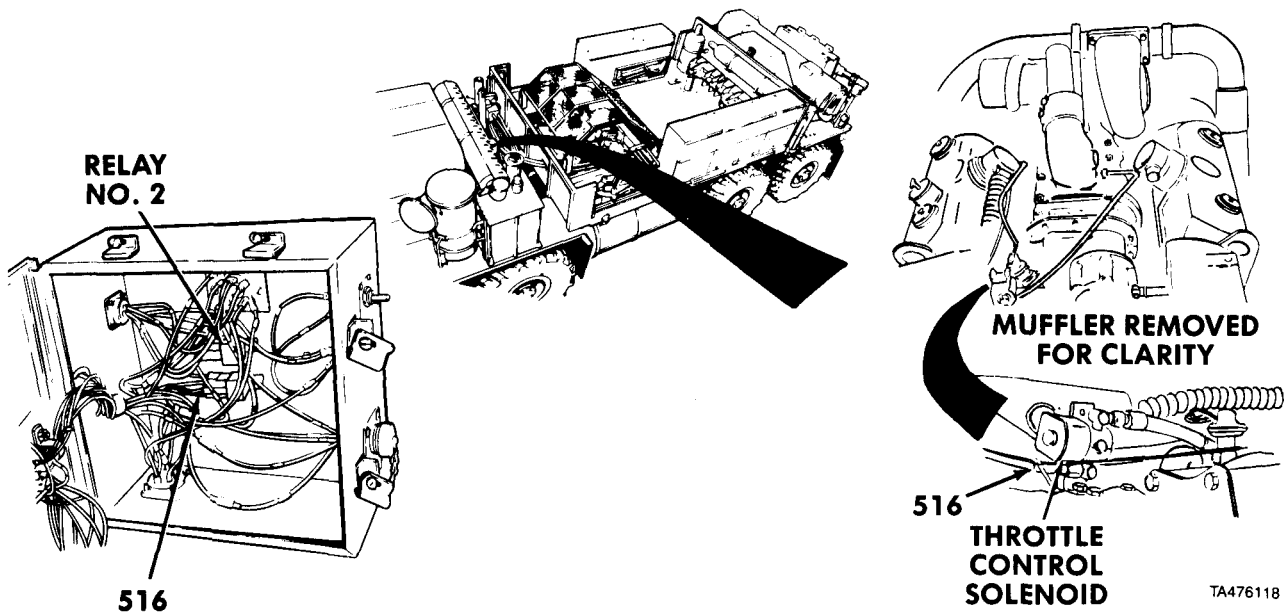
| Malfunction | Test or Inspection | Corrective Action |
|---|---|-------------------|
| ENGINE (CONT) | | |
| 9.1. ENGINE HIGH IDLE DOES NOT OPERATE (M984E1). | | |
| NOTE | | |
| <p>ENGINE HIGH IDLE will not operate unless air pressure is 65 to 75 psi (447 to 515 kPa) or more. If air pressure cannot be built up, go to AIR SYSTEM Troubleshooting.</p> | | |
|  <p>A detailed line drawing showing the connection between an air hose and a high idle solenoid. The air hose is on the left, connected to a solenoid on the right. The solenoid is mounted on a mechanical assembly. The drawing is labeled 'AIR HOSE' and 'HIGH IDLE SOLENOID'.</p> |  <p>A side-view line drawing of a large, heavy-duty truck with multiple axles and large tires. The truck is shown from a three-quarter perspective, facing right. It has a large cab and a long chassis.</p> | TA476116 |
| NOTE | | |
| <p>Air should exhaust from solenoid, not airhose.</p> | | |
| <p>Step 1. Check for damaged airhose between solenoid and engine governor. Replace damaged or leaking airhose.</p> | | |

Troubleshooting Malfunctions (Cont)
Table 2-9. Troubleshooting (Cont)

| Malfunction | Test or Inspection | Corrective Action |
|-------------|--------------------|-------------------|
|-------------|--------------------|-------------------|

ENGINE (CONT)

9.1. ENGINE HIGH IDLE DOES NOT OPERATE (M984E1) (CONT).



CAUTION

Batteries must be disconnected (para 7-8) or damage to test equipment may result. Connect batteries after any fault has been found and corrected.

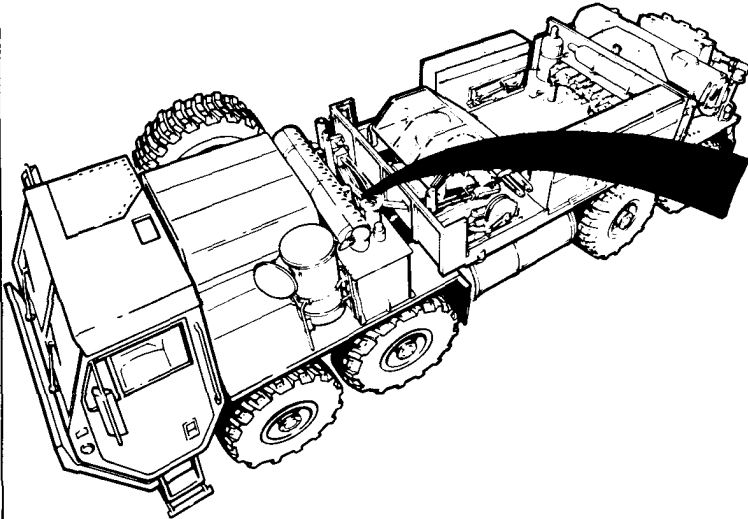
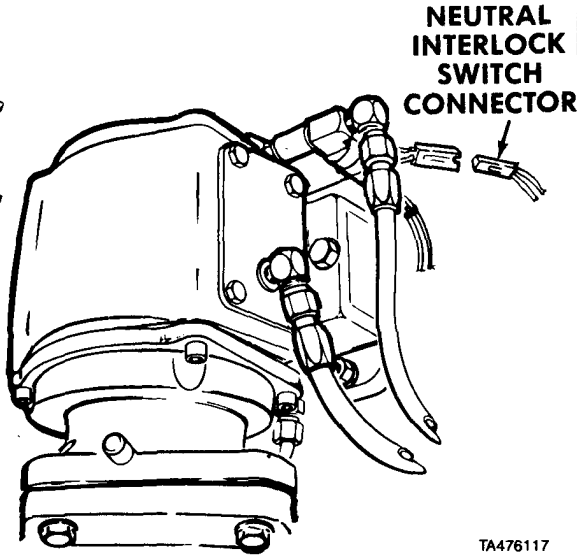
Step 2. Check for defective wire 516 from throttle control solenoid butt connector to relay No. 2 (FO-1 Sheet 6). Open electrical box cover. Test wire resistance.

If resistance is more than zero ohms, repair wire or replace connector.

Troubleshooting Malfunctions (Cont)

2-15. TROUBLESHOOTING INSTRUCTIONS (CONT).

Table 2-9. Troubleshooting (Cont)

| Malfunction | Test or Inspection | Corrective Action |
|--|---|-------------------|
| ENGINE (CONT) | | |
| 9.1. ENGINE HIGH IDLE DOES NOT OPERATE (M984E1) (CONT). | | |
|  |  | TA476117 |
| <p>Step 3. Check for defective neutral interlock switch. Disconnect neutral interlock switch connector on transmission. Place transmission in neutral. Check continuity between two terminals on neutral interlock switch connector.</p> | | |
| <p style="padding-left: 40px;">If resistance is more than zero ohms, replace neutral interlock switch (para 7-97).</p> | | |

Troubleshooting Malfunctions (Cont)
Table 2-9. Troubleshooting (Cont)

| Malfunction | Test or Inspection | Corrective Action |
|--|---|---|
| ENGINE (CONT) | | |
| 9.1. ENGINE HIGH IDLE DOES NOT OPERATE (M984E1) (CONT). | | |
| | Step 4. Check PTO ENGAGE switch for loose or damaged wires. | Tighten loose connections and repair damaged wires. |
| | Step 5. Check PTO ENGAGE switch for continuity. | Replace if defective (para 7-95). |
| | | |
| | Step 6. Check for defective power switch. Remove wires from power switch. Set power switch to ON position. Check continuity between terminals 2 and 3, 5 and 6. | If any resistance reading is more than zero ohms, replace switch (para 52.1). |
| | Step 7. Check for defective power switch wiring. Check resistance of wires 279A, 279B, 279C, 279D, 279E, 279F, 843A. | If resistance is more than zero ohms in any wire, repair wire or replace connector. |

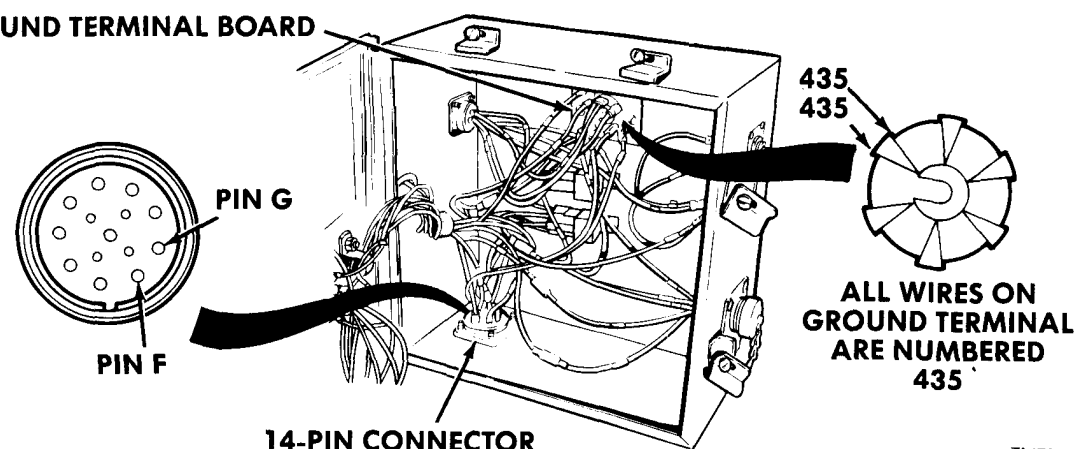
Troubleshooting Malfunctions (Cont)

2-15. TROUBLESHOOTING INSTRUCTIONS (CONT).

Table 2-9. Troubleshooting (Cont)

| Malfunction | Test or Inspection | Corrective Action |
|--|--|--|
| ENGINE (CONT) | | |
| 9.1. ENGINE HIGH IDLE DOES NOT OPERATE (M984E1) (CONT). | | |
| | | REAR VIEW |
| | | TA476120 |
| | <p>Step 8. Check for defective LATCH switch. Remove wires from LATCH switch. Hold switch in LATCH position and check continuity between terminals 1 and 2.</p> | <p>If resistance is more than zero ohms, replace defective LATCH switch (para 7-52.1).</p> |
| | <p>Step 9. Check for defective LATCH switch wiring. Check resistance of wires 279, 279A, 843D, 843E.</p> | <p>If resistance in any wire is more than zero ohms, repair wire or replace connector.</p> |

Troubleshooting Malfunctions (Cont)
Table 2-9. Troubleshooting (Cont)

| Malfunction | Test or Inspection | Corrective Action |
|---|--------------------|-------------------|
| ENGINE (CONT) | | |
| 9.1. ENGINE HIGH IDLE DOES NOT OPERATE (M984E1) (CONT). | | |
|  <p>The diagram illustrates the electrical connections for the engine high idle issue. It shows a 14-pin connector with two specific pins, PIN F and PIN G, highlighted. These pins are connected to a ground terminal board. The ground terminal board has multiple terminals, and all wires connected to it are numbered 435. Two specific wires are also labeled 435. The diagram is labeled TA476121.</p> | | |
| <p>Step 10. Check for defective ground wires from pin G and pin F on 14-pin connector to ground terminal board. Check resistance of wires 435, 435.</p> | | |
| <p style="padding-left: 40px;">If resistance is more than zero ohms in either wire, repair wire or replace connector.</p> | | |

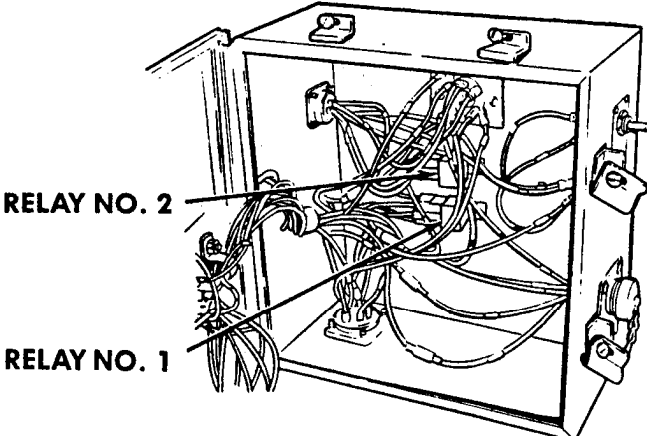
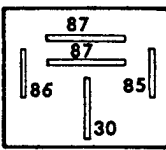
Troubleshooting Malfunctions (Cont)

2-15. TROUBLESHOOTING INSTRUCTIONS (CONT).

Table 2-9. Troubleshooting (Cont)

| Malfunction | Test or Inspection | Corrective Action |
|---|--------------------|-------------------|
| ENGINE (CONT) | | |
| 9.1. ENGINE HIGH IDLE DOES NOT OPERATE (M984E1) (CONT). | | |
| | | |
| <p>Step 11. Check for defective wiring from relay number 2. Check resistance of wire 435 from relay No. 2 to ground terminal board.</p> | | |
| <p style="padding-left: 40px;">If resistance is more than zero ohms in any wire, repair wire or replace connector.</p> | | |
| <p>Step 12. Check for defective wiring from relay No. 1. Check resistance of wire 435 to ground terminal block.</p> | | |
| <p style="padding-left: 40px;">If resistance is more than zero ohms in any wire, repair wire or replace connector.</p> | | |

Troubleshooting Malfunctions (Cont)
Table 2-9. Troubleshooting (Cont)

| Malfunction Test or Inspection | Corrective Action |
|---|--|
| ENGINE (CONT) | |
| 9.1. ENGINE HIGH IDLE DOES NOT OPERATE (M984E1) (CONT). | |
|  |  <p style="text-align: center;">RELAY NO. 1, NO. 2</p> |
| TA476123 | |
| <p>Step 13. Check for defective No. 2 relay. Remove relay No. 2 (para 7-52.1). Attach ground wire to terminal 86 and apply 24 VDC to terminal 85. Listen for clicking sound as relay is energized.</p> <p style="padding-left: 40px;">If relay does not click, replace relay (para 7-52.1).</p> | <p>Step 14. Check for defective relay No. 1. Remove relay No. 1 (para 7-52.1). Attach ground wire to terminal 86 and apply 24 VDC to terminal 85. Listen for clicking sound as relay is energized.</p> <p style="padding-left: 40px;">If relay does not click, replace relay (para 7-52.1). If problem has not been solved, notify direct support maintenance.</p> |

Troubleshooting Malfunctions (Cont)

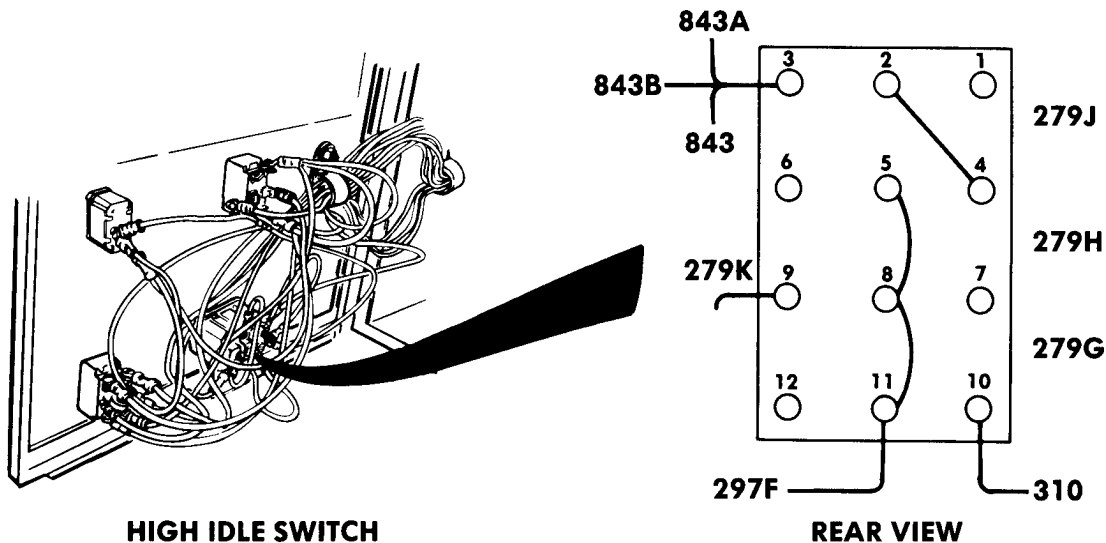
2-15. TROUBLESHOOTING INSTRUCTIONS (CONT).

Table 2-9. Troubleshooting (Cont)

| Malfunction | Test or Inspection | Corrective Action |
|-------------|--------------------|-------------------|
|-------------|--------------------|-------------------|

ENGINE (CONT)

9.2. ENGINE HIGH IDLE DOES NOT OPERATE WHEN CRANING (M984E1).



TA476124

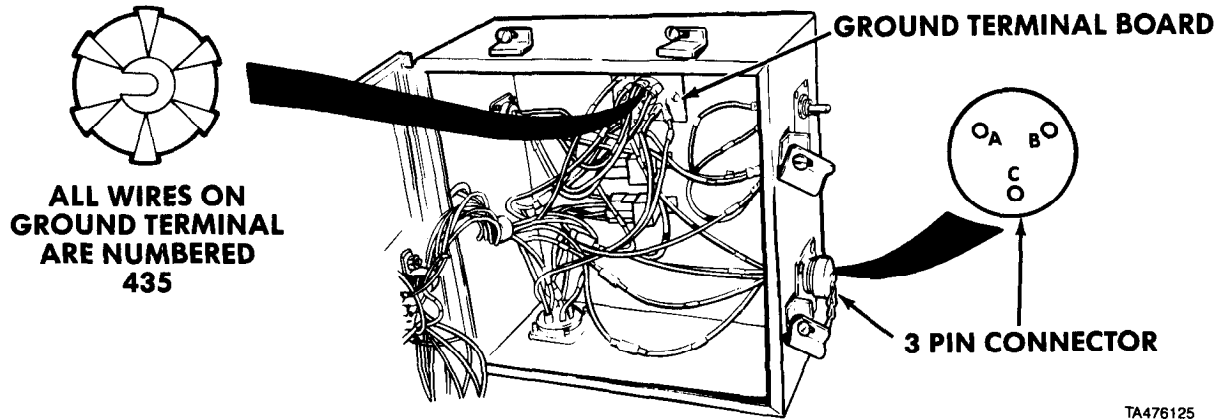
- Step 1. Operate winch HIGH IDLE.
 If HIGH IDLE works go to Step 2.
 If HIGH IDLE does not work, refer to MALFUNCTION 8.1.
- Step 2. Check for defective HIGH IDLE switch. Remove wires from HIGH IDLE switch. Set HIGH IDLE switch to CRANE position, check continuity between terminals 1 and 2, 4 and 5, 7 and 8, 10 and 11.
 If any resistance reading is more than zero ohms, replace HIGH IDLE switch (para 7-52.1).
- Step 3. Check for defective HIGH IDLE switch wiring. Check resistance of wires 279, 843, 843A, 310.
 If resistance is more than zero ohms in any wire, repair wire or replace connector.

Troubleshooting Malfunctions (Cont)
Table 2-9. Troubleshooting (Cont)

| Malfunction | Test or Inspection | Corrective Action |
|-------------|--------------------|-------------------|
|-------------|--------------------|-------------------|

ENGINE (CONT)

9.2. ENGINE HIGH IDLE DOES NOT OPERATE WHEN CRANING (M984E1) (CONT).



TA476125

Step 4. Check for defective wire 435 from pin C on 3-pin connector to ground terminal board. Test wire resistance.

If resistance is more than zero ohms, repair wire or replace connector.

Troubleshooting Malfunctions (Cont)

2-15. TROUBLESHOOTING INSTRUCTIONS (CONT).

Table 2-9. Troubleshooting (Cont)

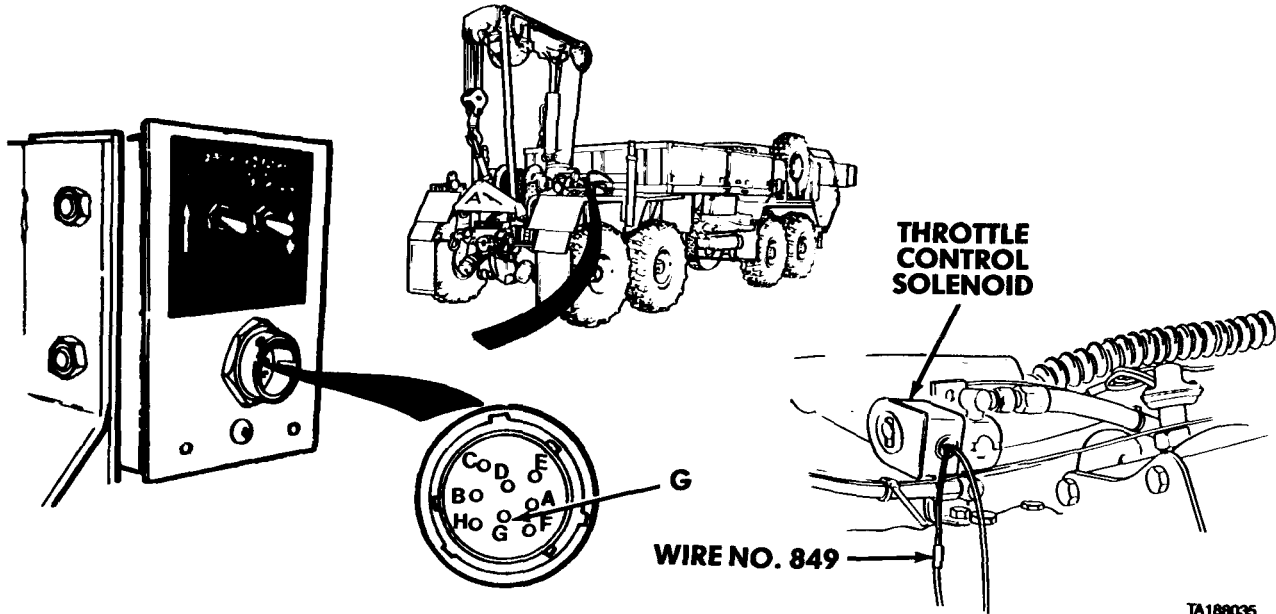
| Malfunction Test or Inspection | Corrective Action |
|---|-------------------|
| ENGINE (CONT) | |
| 10. ENGINE HIGH IDLE DOES NOT OPERATE WHEN USING HEAVY-DUTY WINCH (M984). | |
| NOTE | |
| <ul style="list-style-type: none"> • Check if high idle operates when using crane. If not, go back to MALFUNCTION 9 before going any further. • Winching high idle governed speed is 1800 rpm. Refer to Figure 2-4 for M984 HIGH IDLE Wiring Diagram. | |
| <p style="position: absolute; top: 395px; left: 775px;">TO THROTTLE CONTROL SOLENOID</p> <p style="position: absolute; top: 455px; left: 815px;">NEUTRAL INTERLOCK SWITCH CONNECTOR</p> <p style="position: absolute; top: 555px; left: 815px;">NEUTRAL INTERLOCK SWITCH WIRE</p> <p style="position: absolute; top: 595px; left: 235px;">THROTTLE CONTROL SOLENOID</p> | |
| TA188034 | |
| <p>Step 1. Check for defective neutral interlock switch wire. Disconnect neutral interlock switch on transmission. Test wire resistance when transmission is set to N (neutral). If resistance is more than zero ohms, replace wire.</p> | |

Troubleshooting Malfunctions (Cont)
Table 2-9. Troubleshooting (Cont)

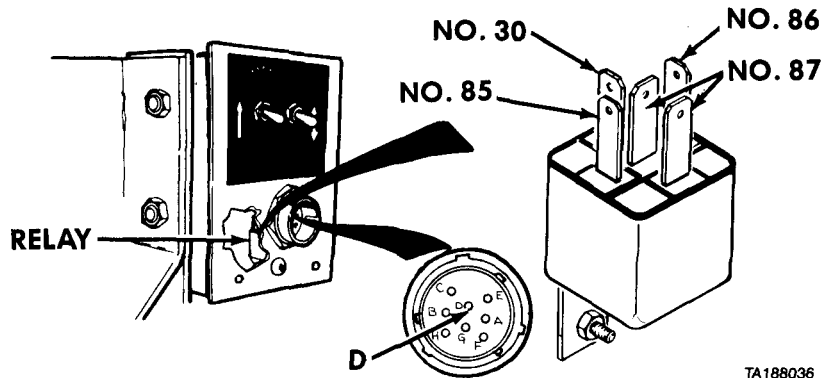
| Malfunction | Test or Inspection | Corrective Action |
|-------------|--------------------|-------------------|
|-------------|--------------------|-------------------|

ENGINE (CONT)

10. ENGINE HIGH IDLE DOES NOT OPERATE WHEN USING HEAVY-DUTY WINCH (M984) (CONT).



Step 2. Disconnect wire No. 849 from throttle control solenoid. Test wire resistance from end of wire to remote control connector pin G.
 If resistance is more than zero ohms, replace wire.



NOTE

Refer to Figure 2-7, Winch Controller Wiring Diagram.

Step 3. Remove rear ENGINE HIGH IDLE control assembly cover. Test resistance from pin D on winch remote control connector to high idle relay terminal No. 30.
 If resistance is more than zero ohms, replace wire.

Troubleshooting Malfunctions (Cont)

2-15. TROUBLESHOOTING INSTRUCTIONS (CONT).

Table 2-9. Troubleshooting (Cont)

| Malfunction | Test or Inspection | Corrective Action |
|---|--------------------|-------------------|
| ENGINE (CONT) | | |
| 10. ENGINE HIGH IDLE DOES NOT OPERATE WHEN USING HEAVY-DUTY WINCH (M984) (CONT). | | |
| | | |
| TA188038 | | |
| Figure 2-7. Winch Controller Wiring Diagram. | | |
| | | |
| TA188039 | | |

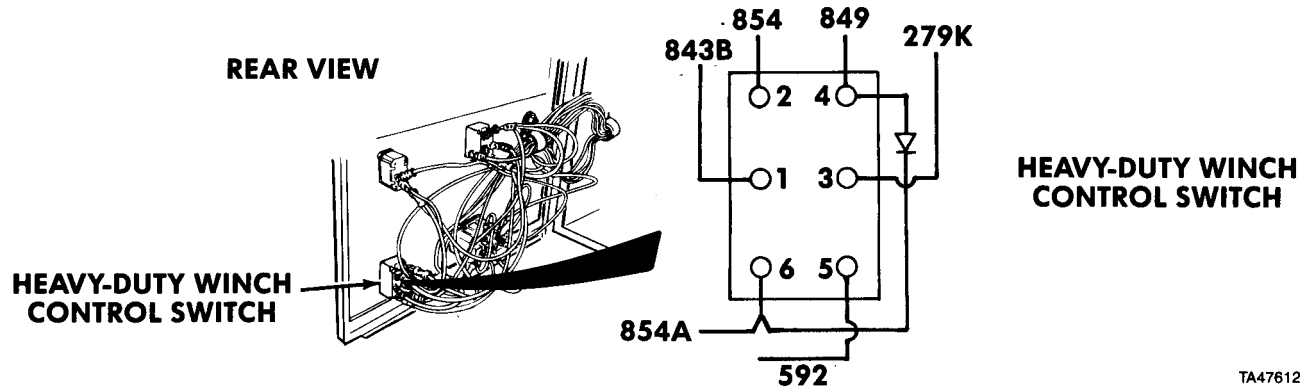
Troubleshooting Malfunctions (Cont)
Table 2-9. Troubleshooting (Cont)

| Malfunction | Test or Inspection | Corrective Action | | | | | | | | | | | | |
|---|--|--|-----------------------------------|-----------------------------------|----------------------------------|---|---|----------|-----------|---|---|---------|---------|--|
| ENGINE (CONT) | | | | | | | | | | | | | | |
| 10. ENGINE HIGH IDLE DOES NOT OPERATE WHEN USING HEAVY-DUTY WINCH (M984) (CONT). | | | | | | | | | | | | | | |
| NOTE | | | | | | | | | | | | | | |
| If more than one wire in remote control cable is defective, replace remote control cable. | | | | | | | | | | | | | | |
| Step 4. | Check for defective winch remote control cable and controller. Remove cover from winch remote controller. | | | | | | | | | | | | | |
| a. | Test resistance between socket G and IN switch diode connection (white wire, wire No. 849). | If resistance is more than zero ohms, replace wire No. 849. | | | | | | | | | | | | |
| b. | Test resistance between socket D and OUT switch terminal NC1. | If resistance is more than zero ohms, replace wire No. 592. | | | | | | | | | | | | |
| c. | Test resistance between socket B and IN switch terminal No. 4. | If resistance is more than zero ohms, replace wire No. 681. | | | | | | | | | | | | |
| d. | Test resistance between socket A and IN switch terminal NC1. | If resistance is more than zero ohms, replace wire No. 682. | | | | | | | | | | | | |
| e. | Test resistance of jumper wires between IN and OUT switches. | If resistance is more than zero ohms, replace wire. | | | | | | | | | | | | |
| f. | Test for defective winch controller. Place negative (-) and positive (+) meter probes in cable connector sockets as shown in chart. Set multimeter to OHMS X1. | If resistance is not approximately as shown, replace defective switch (para 7-10). | | | | | | | | | | | | |
| | <table border="0"> <thead> <tr> <th style="text-align: center;">Negative (-) Probe</th> <th style="text-align: center;">Positive (+) Probe</th> <th style="text-align: center;">Out Switch Pressed</th> <th style="text-align: center;">In Switch Pressed</th> </tr> </thead> <tbody> <tr> <td style="text-align: center;">G</td> <td style="text-align: center;">D</td> <td style="text-align: center;">Infinity</td> <td style="text-align: center;">1000 OHMS</td> </tr> <tr> <td style="text-align: center;">D</td> <td style="text-align: center;">G</td> <td style="text-align: center;">15 OHMS</td> <td style="text-align: center;">15 OHMS</td> </tr> </tbody> </table> | Negative (-) Probe | Positive (+) Probe | Out Switch Pressed | In Switch Pressed | G | D | Infinity | 1000 OHMS | D | G | 15 OHMS | 15 OHMS | |
| Negative (-) Probe | Positive (+) Probe | Out Switch Pressed | In Switch Pressed | | | | | | | | | | | |
| G | D | Infinity | 1000 OHMS | | | | | | | | | | | |
| D | G | 15 OHMS | 15 OHMS | | | | | | | | | | | |
| If problem is not solved, notify the supervisor. | | | | | | | | | | | | | | |

Troubleshooting Malfunctions (Cont)

2-15. TROUBLESHOOTING INSTRUCTIONS (CONT).

Table 2-9. Troubleshooting (Cont)

| Malfunction | Test or Inspection | Corrective Action |
|--|--|-------------------|
| ENGINE (CONT) | | |
| 10.1. ENGINE HIGH IDLE DOES NOT OPERATE WHEN USING HEAVY-DUTY WINCH IN REMOTE CONTROL (M984E1). | | |
| NOTE | | |
| Check if high idle operates when using crane. If not, go back to MALFUNCTION 9.2 before going any further. | | |
| Step 1. Try to operate high idle from the manual station (TM 9-2320-279-10). | | |
| If high idle operates, go to Step 2. | | |
| If high idle does not operate, go to MALFUNCTION 10.2. | | |
| NOTE | | |
| Batteries must be disconnected (para 7-91). Connect batteries after any fault has been found and corrected. | | |
| REAR VIEW |  | |
| HEAVY-DUTY WINCH CONTROL SWITCH | | |
| HEAVY-DUTY WINCH CONTROL SWITCH | | |
| TA476126 | | |
| <p>Step 2. Check for defective heavy-duty winch control switch. Open electrical box cover (para 7-52.1). Remove wires from heavy-duty winch control switch. Set heavy-duty winch control switch to REMOTE position. Check continuity between terminals 1 and 2, 3 and 4. If any resistance reading is more than zero ohms, replace switch (para 7-52.1).</p> | | |
| <p>Step 3. Check for defective heavy-duty winch control switch wiring. Check resistance of wires 843B, 854, 849, 279K. If resistance is more than zero ohms in any wire, repair wire or replace connector.</p> | | |

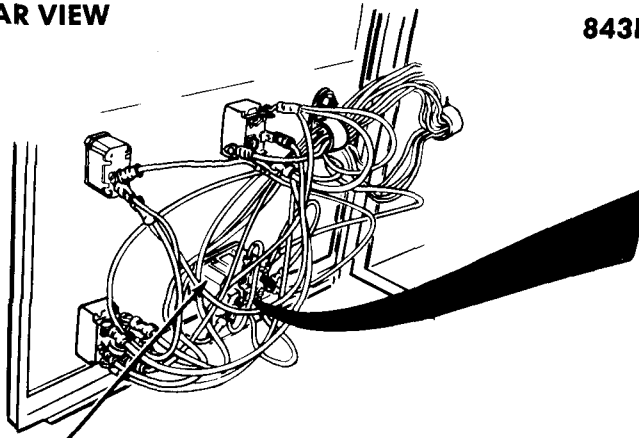
Troubleshooting Malfunctions (Cont)
Table 2-9. Troubleshooting (Cont)

| Malfunction | Test or Inspection | Corrective Action |
|-------------|--------------------|-------------------|
|-------------|--------------------|-------------------|

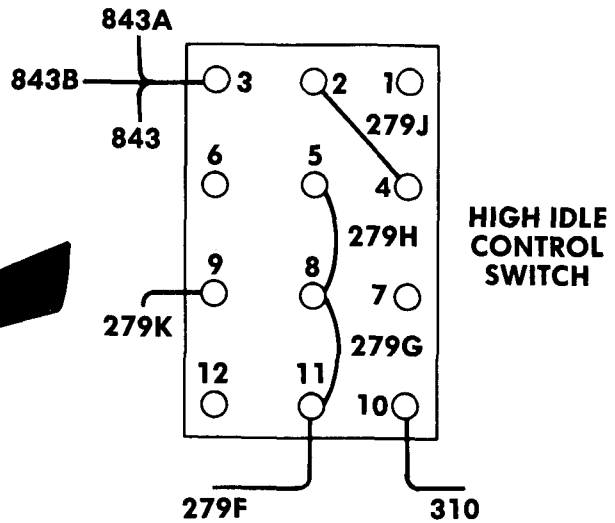
ENGINE (CONT)

10.1. ENGINE HIGH IDLE DOES NOT OPERATE WHEN USING HEAVY-DUTY WINCH IN REMOTE CONTROL (M984E1) (CONT).

REAR VIEW



HIGH IDLE SWITCH



TA476127

- Step 4. Check for defective HIGH IDLE switch. Remove wires from HIGH IDLE switch. Set HIGH IDLE switch to HEAVY-DUTY WINCH. Check continuity between terminals 8 and 9.
 If any resistance reading is more than zero ohms, replace HIGH IDLE switch (para 7-52.1).
- Step 5. Check for defective HIGH IDLE switch wiring. Check resistance of wires 279G and 279K.
 If wire resistance is more than zero ohms, repair wire or replace connector.

Troubleshooting Malfunctions (Cont)

2-15. TROUBLESHOOTING INSTRUCTIONS (CONT).

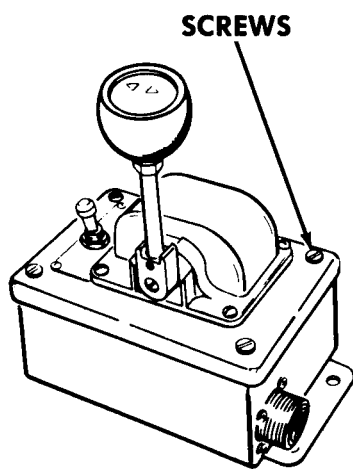
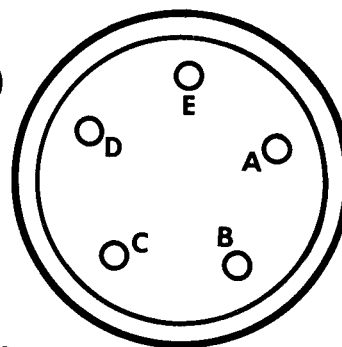
Table 2-9. Troubleshooting (Cont)

| Malfunction | Test or Inspection | Corrective Action |
|-------------|--------------------|-------------------|
|-------------|--------------------|-------------------|

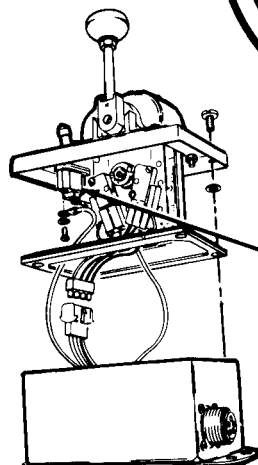
ENGINE (CONT)

10.1. ENGINE HIGH IDLE DOES NOT OPERATE WHEN USING HEAVY-DUTY WINCH IN REMOTE CONTROL (M984E1) (CONT).

**HEAVY-DUTY WINCH
REMOTE CONTROL CABLE
CONNECTOR (BOTH ENDS)**

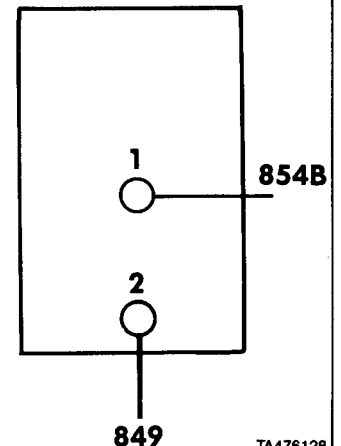


REMOTE CONTROL UNIT



**FAIL-SAFE
SWITCH**

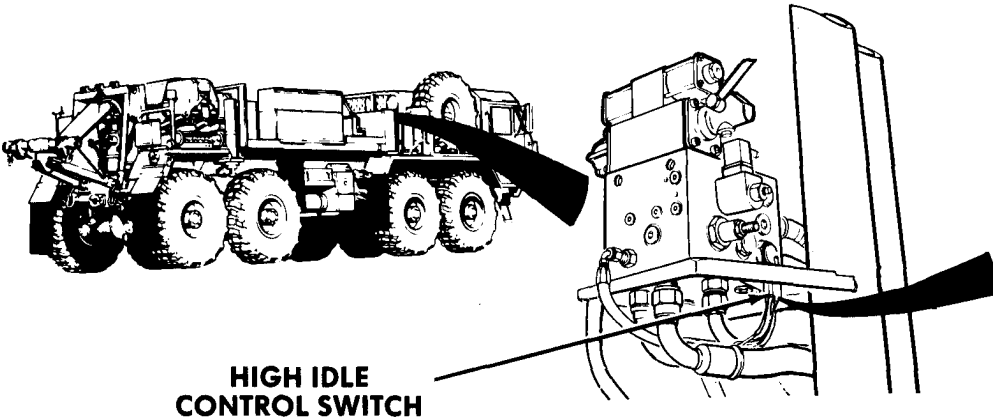
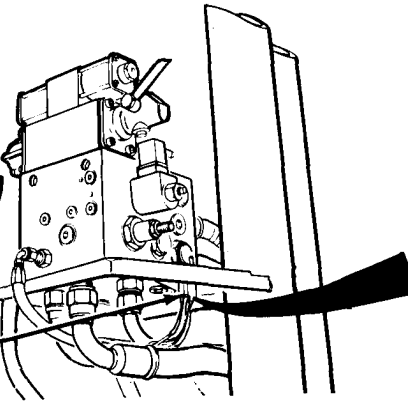
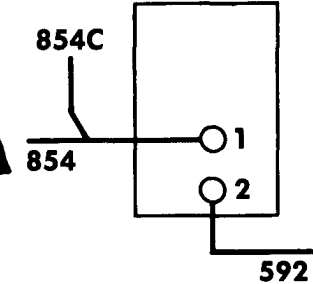
**FAIL-SAFE SWITCH
REAR VIEW**



TA476128

- Step 6. Check each wire in remote controller cable for zero ohms between both ends of cable.
 If meter does not show zero ohms in any wire, repair defective wire.
 If more than two wires are defective, replace remote controller cable.
- Step 7. Check for defective fail-safe switch. Loosen four captive screws and lift cover up to gain access to fail-safe switch. Remove wires from fail-safe switch. Set fail-safe switch to ON position. Check continuity between terminals 1 and 2.
 If resistance reading is more than zero ohms, replace switch (para 17-24.1).
- Step 8. Check for defective fail-safe (ON-OFF) switch wiring. Check resistance of wire 849 from fail safe switch terminal 2 to remote control unit connector pin D, and wire 854B from switch terminal 1 to connector pin C.
 If resistance is more than zero ohms, repair wire.
 If problem remains, notify the supervisor.

Troubleshooting Malfunctions (Cont)
Table 2-9. Troubleshooting (Cont)

| Malfunction | Test or Inspection | Corrective Action |
|---|---|--|
| ENGINE (CONT) | | |
| 10.2. ENGINE HIGH IDLE DOES NOT OPERATE WHEN USING HEAVY-DUTY WINCH IN MANUAL CONTROL (M984E1). | | |
| <p>Step 1. Check if high idle operates when using crane. If not, go back to MALFUNCTION 9.2 before going any further.</p> | | |
| NOTE | | |
| Batteries must be disconnected (para 7-8). | | |
|  <p data-bbox="310 1115 558 1172">HIGH IDLE CONTROL SWITCH</p> |  |  |
| TA476131 | | |
| <p>Step 2. Check for defective HIGH IDLE CONTROL switch. Remove wire from HIGH IDLE CONTROL switch. Set switch to ON. Check continuity between terminals 1 and 2.</p> | | |
| <p style="padding-left: 40px;">If resistance reading is more than zero ohms, replace HIGH IDLE CONTROL switch (para 7-52.1).</p> | | |

Troubleshooting Malfunctions (Cont)

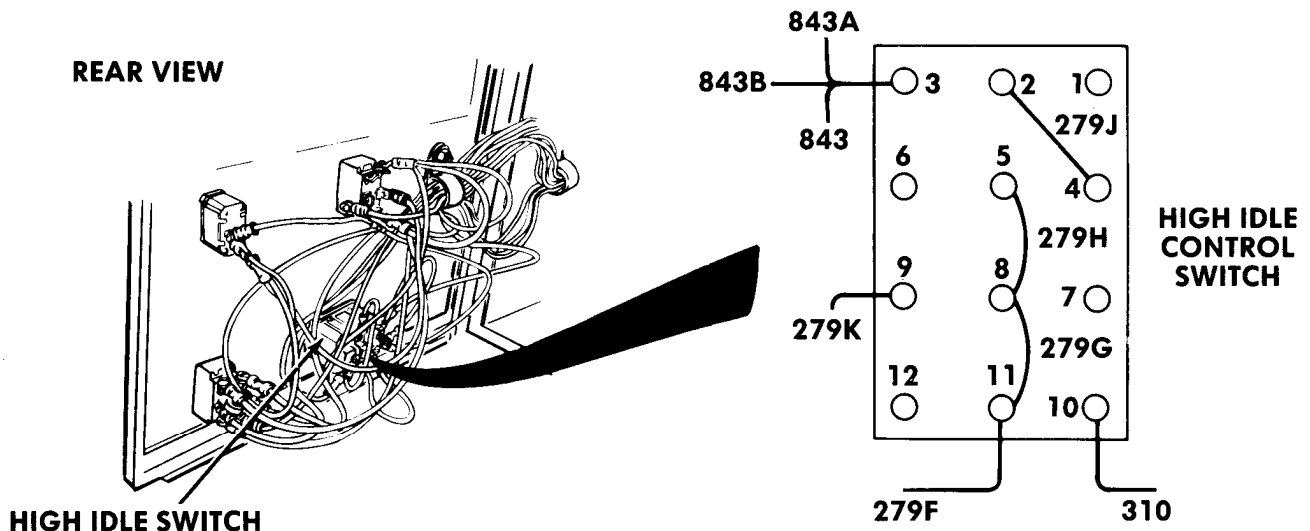
2-15. TROUBLESHOOTING INSTRUCTIONS (CONT).

Table 2-9. Troubleshooting (Cont)

| Malfunction | Test or Inspection | Corrective Action |
|-------------|--------------------|-------------------|
|-------------|--------------------|-------------------|

ENGINE (CONT)

10.2. ENGINE HIGH IDLE DOES NOT OPERATE WHEN USING HEAVY-DUTY WINCH IN MANUAL CONTROL (M984E1) (CONT).



TA476127

- Step 3. Check for defective HIGH IDLE CONTROL switch. Remove wires from HIGH IDLE CONTROL switch. Set switch to H.D. WINCH. Check continuity between terminals 8 and 9.
 If resistance reading is more than zero ohms, replace HIGH IDLE CONTROL switch (para 7-52.1).
- Step 4. Check for defective HIGH IDLE CONTROL switch wiring. Check resistance of wires 279G, 279K.
 If resistance reading is more than zero ohms, repair wire or replace connector.

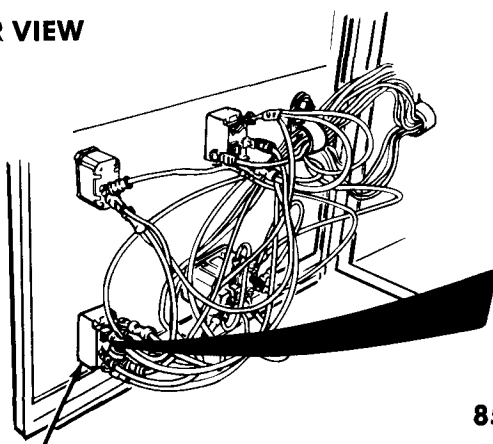
Troubleshooting Malfunctions (Cont)
Table 2-9. Troubleshooting (Cont)

| Malfunction | Test or Inspection | Corrective Action |
|-------------|--------------------|-------------------|
|-------------|--------------------|-------------------|

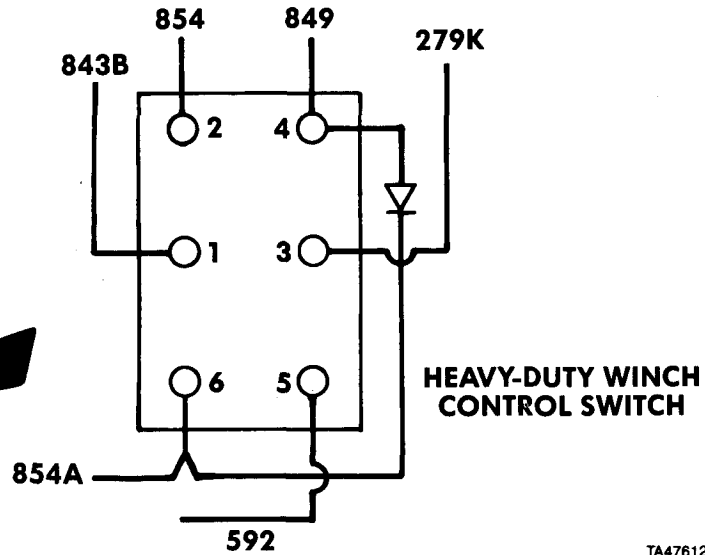
ENGINE (CONT)

10.2. ENGINE HIGH IDLE DOES NOT OPERATE WHEN USING HEAVY-DUTY WINCH IN MANUAL CONTROL (M984E1) (CONT).

REAR VIEW



HEAVY-DUTY WINCH CONTROL SWITCH



TA476126

- Step 5. Check for defective heavy-duty winch control switch. Open electrical box cover (para 7-52.1). Remove wires from heavy-duty winch control switch. Set heavy-duty winch control switch to MANUAL position. Check continuity between terminals 1 and 6, 3 and 5.
- If any resistance reading is more than zero ohms, replace switch (para 17-52.1).
- Step 6. Check for defective heavy-duty winch control switch wiring. Check resistance of wires 843B, 854A, and 592.
- If resistance is more than zero ohms in any wire, repair wire or replace connector.

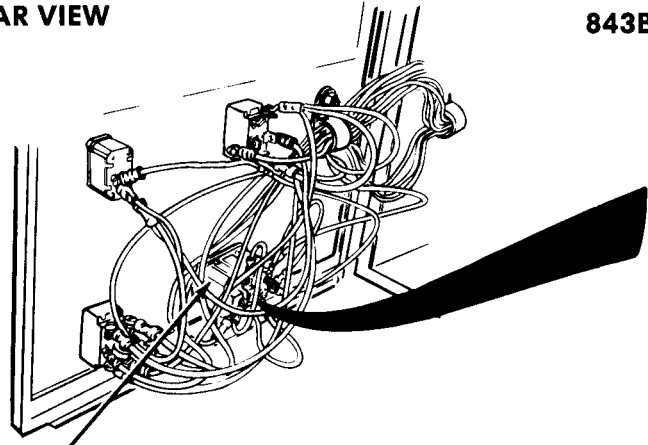
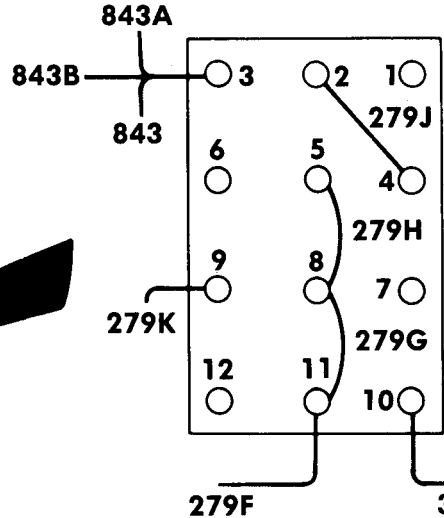
Troubleshooting Malfunctions (Cont)

2-15. TROUBLESHOOTING INSTRUCTIONS (CONT).

Table 2-9. Troubleshooting (Cont)

| Malfunction | Test or Inspection | Corrective Action |
|---|---|---|
| ENGINE (CONT) | | |
| 10.2. ENGINE HIGH IDLE DOES NOT OPERATE WHEN USING HEAVY-DUTY WINCH IN MANUAL CONTROL (M984E1) (CONT). | <p>The diagram illustrates the electrical connection for the high idle control switch. On the left, a truck is shown with a callout to the 'HIGH IDLE CONTROL SWITCH'. A detailed view of the switch shows 'PIN K' and 'PIN M' terminals. A '14 PIN CONNECTOR' is shown with wires connected to it. A wiring schematic to the right shows terminal 1 connected to wire 854C, terminal 2 connected to wire 854, and terminal 2 also connected to wire 592.</p> | TA476130 |
| | <p>Step 7. Check for defective wires from pin M and pin K on 14-pin connector to HIGH IDLE switch. Check resistance of wires 854, 854A, and 592.</p> | <p>If resistance is more than zero ohms in either wire, repair wire or replace connector.</p> |

Troubleshooting Malfunctions (Cont)
Table 2-9. Troubleshooting (Cont)

| Malfunction Test or Inspection | Corrective Action |
|---|---|
| ENGINE (CONT) | |
| 10.3. ENGINE HIGH IDLE DOES NOT OPERATE WHEN USING RETRIEVER SYSTEM (M984E1). | |
| <p>Step 1. Check if HIGH IDLE operates when using crane. If not, go back to MALFUNCTION 9.2 before going any further.</p> | |
| <p>NOTE Batteries MUST be disconnected (para 7-91).</p> | |
| <p>REAR VIEW</p>  <p>HIGH IDLE SWITCH</p> |  <p>HIGH IDLE CONTROL SWITCH</p> <p style="text-align: right;">TA476127</p> |
| <p>Step 2. Check for defective HIGH IDLE CONTROL switch. Remove wires from HIGH IDLE CONTROL switch. Set HIGH IDLE CONTROL switch to CONTINUOUS. Check continuity between terminals 4 and 5, 2 and 3.</p> <p style="padding-left: 40px;">If any resistance reading is more than zero ohms, replace HIGH IDLE CONTROL switch (para 17-52.1).</p> | |
| <p>Step 3. Check for defective HIGH IDLE CONTROL switch wiring. Check resistance of wires 279G, 279H, 279J.</p> <p style="padding-left: 40px;">If resistance is more than zero ohms in any wire, repair wire or replace connector.</p> | |

Troubleshooting Malfunctions (Cont)

2-15. TROUBLESHOOTING INSTRUCTIONS (CONT).

Table 2-9. Troubleshooting (Cont)

| Malfunction | Test or Inspection | Corrective Action |
|---|--|--|
| FUEL SYSTEM | | |
| 1. ENGINE WILL NOT START, OR STALLS. | | |
| | Step 1. Check fuel level in tank. | If empty, check tank for damage. If tank is damaged, replace (para 4-7). If no damage, add fuel and bleed air from fuel system (par 2-18). |
| | Step 2. Check fuel lines for loose fittings and connections. | Tighten loose fittings and connections. |
| | Step 3. Inspect for damaged fuel lines. | Replace damaged fuel line (para 4-6). |
| | Step 4. Check secondary fuel filter for leaks or damage. | Tighten if loose, replace if damaged (para 4-11). |
| | | |
| | Step 5. Check if T-handle on top of fuel-water separator is loose. | If loose, tighten T-handle on top of fuel-water separator. |

Troubleshooting Malfunctions (Cont)
Table 2-9. Troubleshooting (Cont)

| Malfunction | Test or Inspection | Corrective Action |
|-------------|--------------------|-------------------|
|-------------|--------------------|-------------------|

FUEL SYSTEM (CONT)

1. ENGINE WILL NOT START, OR STALLS (CONT).

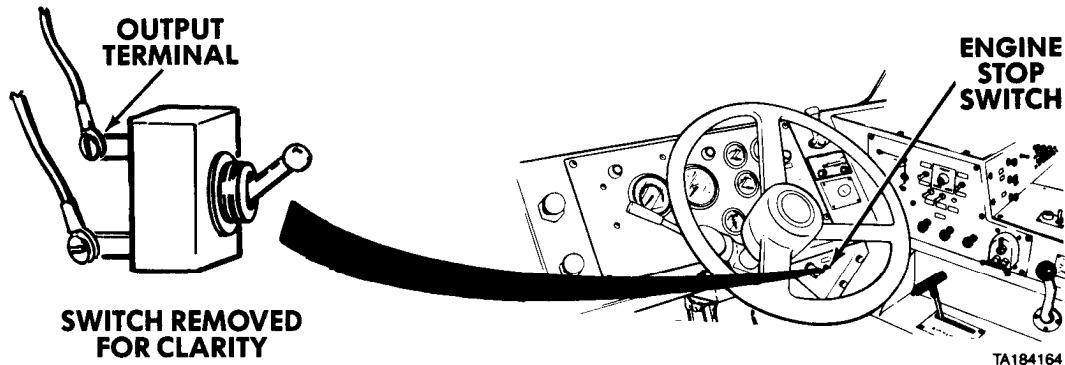
Step 6. Check fuel-water separator bowl for contamination.

Open valve outlet to drain contaminated fuel.

If problem is not solved, drain contaminated fuel from fuel tank and refill fuel tank with clean fuel.

Step 7. Disassemble fuel-water separator and check for damaged check valve and seat (para 4-9).

Clean or replace seat and check valve (para 4-9).



Step 8. Check ENGINE STOP switch for voltage on output terminal when switch is in the run position.

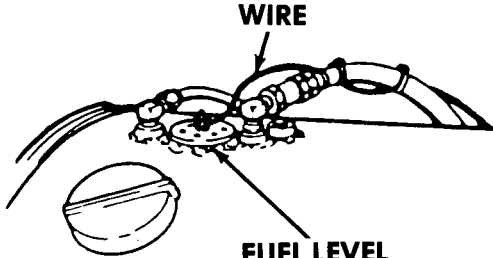
If there is voltage, replace switch (para 7-38).

Step 9. If engine still does not start, notify the supervisor.

Troubleshooting Malfunctions (Cont)

2-15. TROUBLESHOOTING INSTRUCTIONS (CONT).

Table 2-9. Troubleshooting (Cont)

| Malfunction | Test or Inspection | Corrective Action |
|---|--|---|
| FUEL SYSTEM (CONT) | | |
| 2. ENGINE CRANKS BUT DOES NOT START WHEN ETHER INJECTOR IS ACTUATED IN COLD WEATHER. | | |
| | | NOTE |
| | | Coolant temperature must be below 55 °F (13 °C) to activate ether injector system. |
| | Step 1. Check that ether cylinder is handtight. | Tighten ether cylinder. |
| | Step 2. Check ether supply. | Remove ether cylinder (para 4-12). Replace empty bottle (para 4-12). |
| | Step 3. Check engine starting aid tubing for damage. | Replace damaged tubing (para 4-12). |
| | Step 4. Check ether injector valve for damage. | If damaged, replace ether injector valve (para 4-12). |
| | Step 5. Go to ELECTRICAL SYSTEM Troubleshooting, MALFUNCTION 14, ETHER STARTING AID DOES NOT WORK. | |
| 3. FUEL LEVEL GAGE DOES NOT REGISTER OR REGISTERS INACCURATELY. | | |
| | |  <p data-bbox="998 1635 1068 1652">TA184171</p> |
| | Step 1. Check fuel gage and sending unit. | Remove wire in center of sending unit. Turn ENGINE switch ON. Touch wire to ground. |
| | | If fuel gage reads full, replace sending unit (para 7-80). |
| | | If fuel gage does not register, replace fuel gage (para 7-23). |

Troubleshooting Malfunctions (Cont)

2-15. TROUBLESHOOTING INSTRUCTIONS (CONT).

Table 2-9. Troubleshooting

| Malfunction Test or Inspection | Corrective Action |
|--|--|
| ELECTRICAL SYSTEM | |
| NOTE | |
| <ul style="list-style-type: none"> · Repair of electrical harnesses is limited to splicing new wires into the harness with crimp connectors, taping the new wire to the harness, and replacing electrical connectors. If two or more wires in a harness are found to be defective, notify the supervisor for repair or replacement of harness. Wires that are not in a harness can be replaced or repaired as required. · There are many different types of electrical connectors used to attach wires or cables to electrical components on the vehicle. To install wires in crimp-type connectors, refer to FM 55-506-1. | |
| 1. BATTERY WEAK OR FAILS TO MAINTAIN CHARGE. | |
| Step 1. | Check that BATTERY gage reads 22 volts (min) with ENGINE switch ON. If not, service batteries (TM 9-6140-200-14). |
| Step 2. | Check for loose, damaged or missing alternator belts. Adjust loose belts (para 6-14) or replace damaged or missing belts (para 6-15). |
| Step 3. | Check battery cables and alternator wiring for continuity. Repair broken wires and connectors. |
| Step 3.1 | Check that wire No. 831 at regulator has 22 volts (min) with ENGINE switch ON. If not, perform step 3.2. |
| Step 3.2 | Remove circuit breaker compartment cover (para 7-43). Check circuit breaker No. 9 for continuity (fig. 2-2). Replace defective circuit breaker No. 9 (para 7-43). |
| Step 4. | Perform alternator test (para 7-2). If voltage is low, adjust regulator (para 7-6), then replace regulator or alternator (para 7-5 or 7-3) as necessary. |

Troubleshooting Malfunctions (Cont)

Table 2-9 Troubleshooting (Cont)

| Malfunction | Test or Inspection | Corrective Action |
|---------------------------------------|---|---|
| ENGINE BRAKE WILL NOT OPERATE. | | |
| Step 1. | Remove circuit breaker compartment cover (para 7-43). Check circuit breaker No.9 for continuity (fig. 2-2). | Replace defective circuit breaker No. 9 (para 7-43). |
| Step 2. | Check for 24 volts at input terminal on circuit breaker No. 9 (para 7-43). | If 24 volts is not present, trace wiring and find problem. Refer to FO-1, Electrical Diagram. |
| Step 3 | Check for loose or broken wires and connections. Refer to FO-1, Electrical Diagram. | Tighten loose connections, repair broken wires and connections. |
| Step 4. | Check engine brake wiring for continuity. | Repair defective wires. |
| Step 5. | Remove dash side panel, check engine brake ON/OFF switch for continuity. | Replace engine brake ON/OFF switch if defective (para 7-39). |
| Step 6. | Check engine brake HIGH/LOW switch for continuity. | Replace if defective (para 7-39). |
| Step 7. | If problem is not solved, notify the supervisor. | |

Troubleshooting Malfunctions (Cont)

Table 2-9 Troubleshooting (Cont)

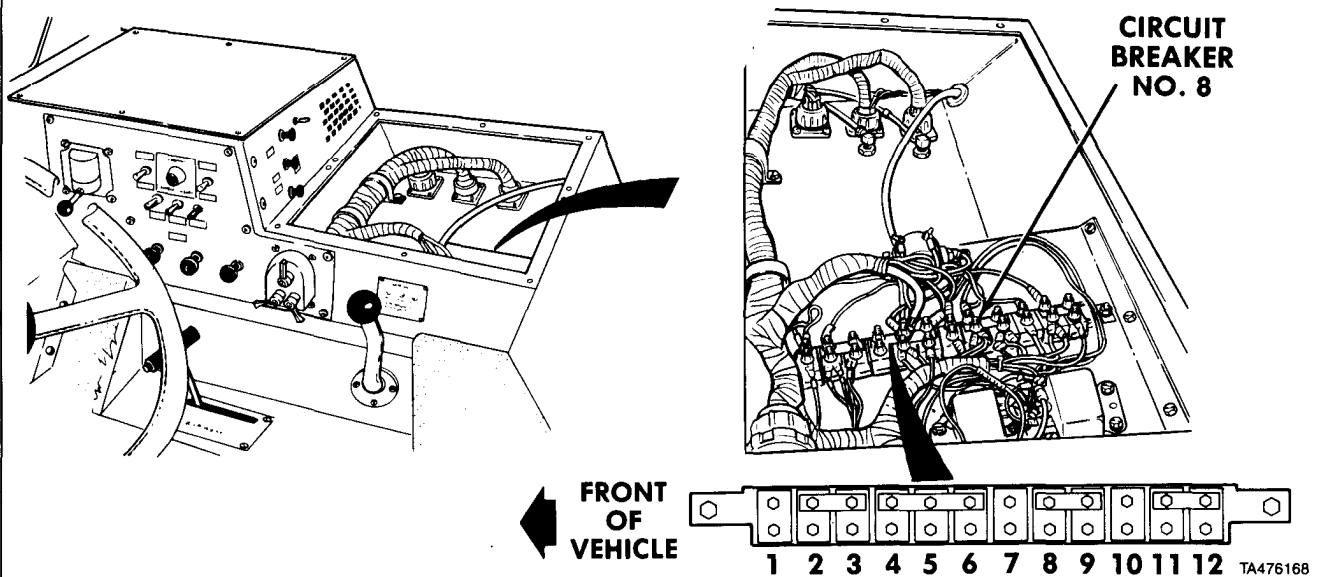
| Malfunction | Test or Inspection | Corrective Action |
|---|--|--|
| ELECTRICAL SYSTEM (CONT) | | |
| 3. HEATER FAN MOTOR WILL NOT OPERATE. | | |
| <p>The diagram shows a side view of a vehicle's dashboard and heater compartment. A thick black arrow points from the heater compartment cover to the motor. To the right, a detailed view of the heater compartment shows the motor, heater resistor, and connector. Labels include HEATER COMPARTMENT COVER, MOTOR, and CONNECTOR RESISTOR.</p> | | |
| Step 1. | Remove heater compartment cover, and check heater fan switch and wiring for continuity. | Replace defective heater fan switch (para 7-42) or repair wiring. |
| Step 2. | Check heater resistor coils for continuity. | Replace defective resistor (para 18-19). |
| Step 3. | Check heater wiring circuit for continuity. Refer to FO-1, Electric Diagram. | If heater wiring circuit is defective, repair defective wires or connectors. |
| Step 4 | Use multimeter to check voltage going into heater is 22-28 volts. | If voltage is 22-28 volts, replace motor (para 18-20). |
| Step 5. | Remove heater compartment cover. Check circuit breaker No. 11 for continuity (fig. 2-2). | Replace defective circuit breaker No. 11 (para 7-43). |
| Step 6. | Check for 24 vdc at input terminal at circuit breaker No. 5. | If 24 vdc is not present, trace wiring and find problem. Refer to FO-1 Electric Diagram. |

Troubleshooting Malfunctions (Cont)
Table 2-9. Troubleshooting (Cont)

| Malfunction | Test or Inspection | Corrective Action |
|-------------|--------------------|-------------------|
|-------------|--------------------|-------------------|

ELECTRICAL SYSTEM (CONT)

4. POWER TAKEOFF (PTO) SWITCH WILL NOT ENGAGE.



Step 1. Remove left and right heater compartment covers (para 16-11). Check circuit breaker No. 8 for continuity across contacts.

If no continuity, replace circuit breaker No. 8 (para 7-43).

Troubleshooting Malfunctions (Cont)

2-15. TROUBLESHOOTING INSTRUCTIONS (CONT).

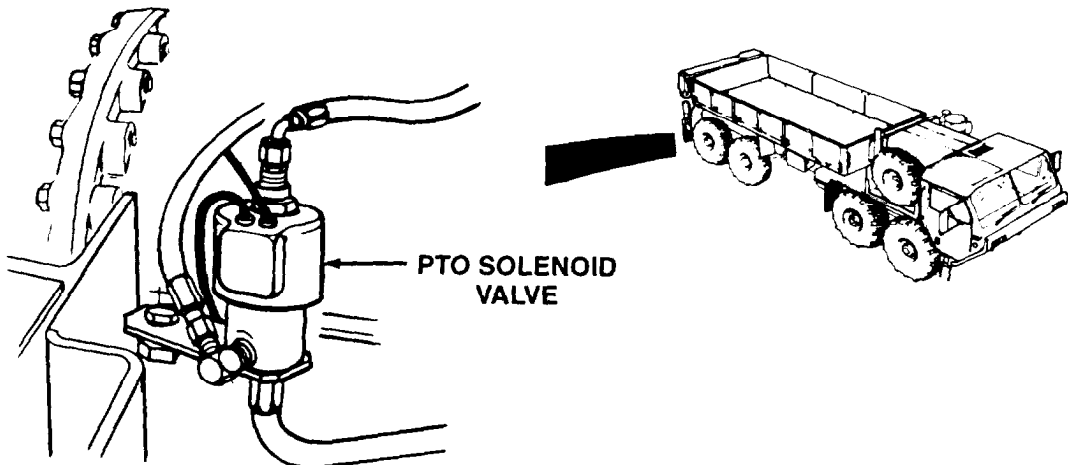
Table 2-9. Troubleshooting (Cont)

| Malfunction | Test or Inspection | Corrective Action |
|--|---|-------------------|
| ELECTRICAL SYSTEM (CONT) | | |
| 4. POWER TAKEOFF (PTO) SWITCH WILL NOT ENGAGE (CONT). | | |
| | | |
| | <p>Step 2. Check PTO ENGAGE switch for continuity. Replace if defective (para 7-95).</p> | |
| | <p>Step 3. Check for loose or damaged wires on PTO ENGAGE switch. Tighten loose connections and repair damaged wires.</p> | |

Troubleshooting Malfunctions (Cont)

2-15. TROUBLESHOOTING INSTRUCTIONS (CONT).

Table 2-9. Troubleshooting (Cont)

| Malfunction | Test or Inspection | Corrective Action |
|---|---|--|
| ELECTRICAL SYSTEM (CONT) | | |
| POWER TAKEOFF (PTO) SWITCH WILL NOT ENGAGE (CONT). | | |
|  | | |
| Step 4. | Turn engine start switch to ON position, turn PTO ENGAGE switch ON and OFF several times while touching PTO solenoid to feel for vibration (listen for clicking). | <p>If PTO solenoid valve vibrates (clicks), refer to Step 6.</p> <p>If solenoid does not click, go to Step 5.</p> |
| Step 5. | Check solenoid wires for loose connections, damage, and continuity. | <p>Tighten loose connections, repair damaged wires and replace wires with no continuity.</p> <p>If all wires and connections are okay, replace PTO solenoid (para 7-30).</p> |
| Step 6. | If PTO still will not engage, refer to Hydraulic System Troubleshooting (page 2-153). | |
| Step 7. | Deleted. | |
| Step 8. | Deleted. | |
| All data on page 2-119 deleted. | | |

Troubleshooting Malfunctions (Cont)

2-15. TROUBLESHOOTING INSTRUCTIONS (CONT).

Table 2-9. Troubleshooting (Cont)

| Malfunction | Test or Inspection | Corrective Action |
|--|--------------------|-------------------|
| ELECTRICAL SYSTEM (CONT) | | |
| 4. POWER TAKEOFF (PTO) SWITCH WILL NOT ENGAGE (CONT). | | |
| | | |
| <p>Step 6. Remove hydraulic hose from tee connection, place hose end in suitable container. Start engine, engage PTO switch.</p> | | |
| <p style="padding-left: 40px;">If hydraulic oil discharges into container, go to Step 7.</p> | | |
| <p style="padding-left: 40px;">If no oil discharges, go to Step 8.</p> | | |
| <p>Step 7. Remove tee and check for clogged filter.</p> | | |
| <p style="padding-left: 40px;">Clean if required. If PTO still does not work, replace PTO (para 17-28) (M984E1: para 17-28.1).</p> | | |

Troubleshooting Malfunctions (Cont)

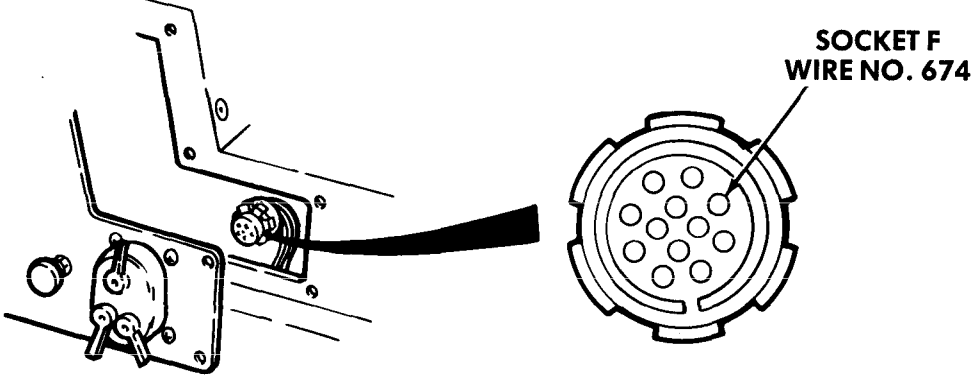
2-15. TROUBLESHOOTING INSTRUCTIONS (CONT).

Table 2-9. Troubleshooting (Cont)

| Malfunction | Test or Inspection | Corrective Action |
|---|--|---|
| ELECTRICAL SYSTEM (CONT) | | |
| 5. ONE OR MORE LIGHTS NOT WORKING (WARNING OR SERVICE LIGHTS). | | |
| NOTE | | |
| If composite lights on vehicle are LED type, perform steps (3), (4.1), and (4.2). | | |
| Step 1. | Make visual check for burned out light bulb. | Replace light bulb. |
| Step 2. | Check socket and/or contacts for corrosion. | Clean socket and/or contacts. |
| Step 3. | Check for proper ground. | Clean ground connection. |
| Step 4. | Turn light switch to ON and check socket for 22-28 volts. | If there is 22-28 volts, replace defective lamp or bulb. |
| Step 4.1. | Turn light switch to ON and check for 22-28 volts at chassis wire harness connectors, wire 1008/21, connected to both rear LED composite lights. | If there is 22-28 volts, replace LED composite light (para 7-62). |
| Step 4.2. | Turn light switch to ON and check for 22-28 volts at cab wire harness connectors, wire 1491, connected to both front LED composite lights. | If there is 22-28 volts, replace LED composite light (para 7-62). |

Troubleshooting Malfunctions (Cont)

Table 2-9. Troubleshooting (Cont)

| Malfunction | Test or Inspection | Corrective Action |
|---|--|--|
| ELECTRICAL SYSTEM (CONT) | | |
| 5. ONE OR MORE LIGHTS NOT WORKING (WARNING OR SERVICE LIGHTS) (CONT). | | |
| Step 5. | Check wiring harness for loose connections or broken parts. | Repair wiring harness and/or replace broken pins. |
| Step 6. | Check for defective main light switch. | Operate light switch (TM 9-2320-279-10). |
|  <p>The diagram illustrates the electrical connection between a main light switch and a connector. On the left, a metal bracket holds a switch mechanism with a knob. A cable with a circular connector is attached to the switch. On the right, a circular connector with multiple pins is shown, with a label 'SOCKET F WIRE NO. 674' pointing to one of the pins.</p> | | |
| Step 7. | Disconnect connector from back of main light switch (para 7-41). Set multimeter to test for 24 vdc. Place negative (-) probe to a ground and touch positive (+) probe to socket F (wire 674) on connector. Meter should show 24 vdc. | <p>If meter does not show 24 vdc, trace wiring and find problem. Refer to FO-1, Electric Diagram.</p> <p>If meter shows 24 vdc, replace defective main light switch (para 7-41).</p> |
| 6. DIMMER SWITCH FAILS TO OPERATE. | | |
| Step 1. | Check dimmer switch for continuity. | Replace defective dimmer switch (para 7-102). |
| Step 2. | Check dimmer switch wiring circuit for continuity. Refer to FO-1, Electric Diagram. | Repair or replace defective wires or connectors. |

Troubleshooting Malfunctions (Cont)

Table 2-9. Troubleshooting (Cont)

| Malfunction Test or Inspection | Corrective Action |
|--|--|
| ELECTRICAL SYSTEM (CONT) | |
| 7. STOPLIGHTS DO NOT WORK. | |
| NOTE | |
| If composite lights on vehicle are LED type, perform step (1.1). | |
| Step 1. Check for burned out stoplight lamp or damaged stoplight. | Remove lamp (para 7-60) and replace lamp if burned out. |
| | Replace damaged stoplight (para 7-62). |
| | Replace damaged high-mount stoplight (M978) (para 7-62.1). |
| Step 1.1. Check for damaged or defective LED composite lights. | Replace LED composite light (para 7-62). |
| | |
| Step 2. Check for loose or damaged electrical connections at stoplights and stoplight switches. | Tighten loose connections. Replace damaged connections. |
| NOTE | |
| <ul style="list-style-type: none"> • If service brake stoplights do not operate, go to Step 3. • If trailer hand brake stoplights do not operate, go to Step 4. • If emergency tow stoplights do not operate, go to Step 5. | |

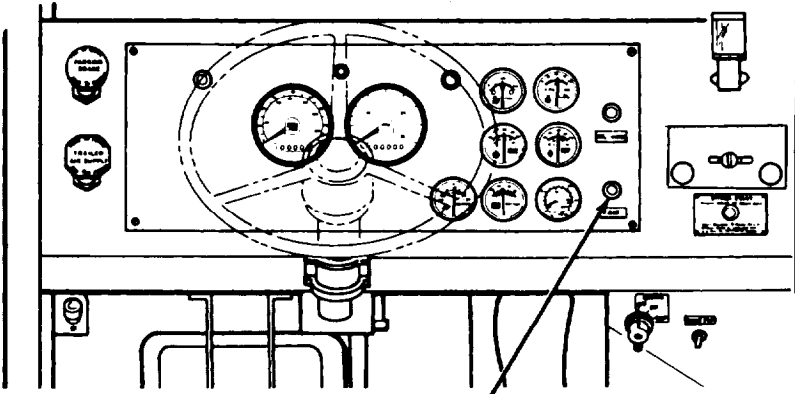
Troubleshooting Malfunctions (Cont)

Table 2-9. Troubleshooting (Cont)

| Malfunction | Test or Inspection | Corrective Action |
|---|---|--|
| ELECTRICAL SYSTEM (CONT) | | |
| 7. STOPLIGHTS DO NOT WORK (CONT). | | |
| Step 3. | Check for defective service brake stoplight switches. Start engine, build air pressure up to 100 to 120 psi (690 to 827 kPa). Shut off engine. Remove wires from service brake stoplight switches. Press on brake pedal, check for continuity of service brake stoplight switches. | If no continuity, replace service brake stoplight switch(es) (para 7-46). If continuity, go to Step 6. |
| Step 4. | Check for defective trailer hand brake stoplight switch. Start engine, build air pressure up to 100 to 120 psi (690 to 827 kPa). Shut off engine. Remove wires from trailer hand brake stoplight switch. Apply trailer hand brake, check for continuity at trailer hand brake stoplight switch. | If no continuity is found, replace trailer hand brake stoplight switch (para 11-20). If continuity, go to Step 6. |
| NOTE | | |
| Disabled vehicle's electrical system must be operational in order for stoplights to work. | | |
| Step 5. | Check for defective emergency tow stoplight switch. Hook up disabled vehicle correctly to air lines and charge trailer air system. Remove wires from emergency tow stoplight switch. Press on brake pedal on tow vehicle, check for continuity at emergency tow stoplight switch on disabled vehicle. | If no continuity is found, replace emergency tow stoplight switch (para 11-14). If continuity, go to Step 6. |
| Step 6. | Check for defective turn signal switch. Disconnect batteries (para 7-91). Disconnect wires 294, 003, and 004 from turn signal switch (para 7-50). With turn signal switch in neutral, check for continuity between wire 294 (switch side) and 003 (switch side). With turn signal switch in neutral, check for continuity between wire 294 (switch side) and 004 (switch side). | If no continuity is found, replace turn signal switch (para 7-50). |

Troubleshooting Malfunctions (Cont)

Table 2-9. Troubleshooting (Cont)

| Malfunction | Test or Inspection | Corrective Action |
|---|--|-------------------|
| ELECTRICAL SYSTEM (CONT) | | |
| B. | AIR PRESSURE WARNING LIGHT AND BUZZER DO NOT WORK WHEN AIR PRESSURE DROPS BELOW APPROXIMATELY 65 PSI (448 kPa). | |
|  | | |
| AIR PRESSURE WARNING INDICATOR LIGHT | | |
| Step 1. | <p>Check for burned out air pressure warning indicator light. Remove lamp (para 7-31) and replace burned out lamp.</p> | |

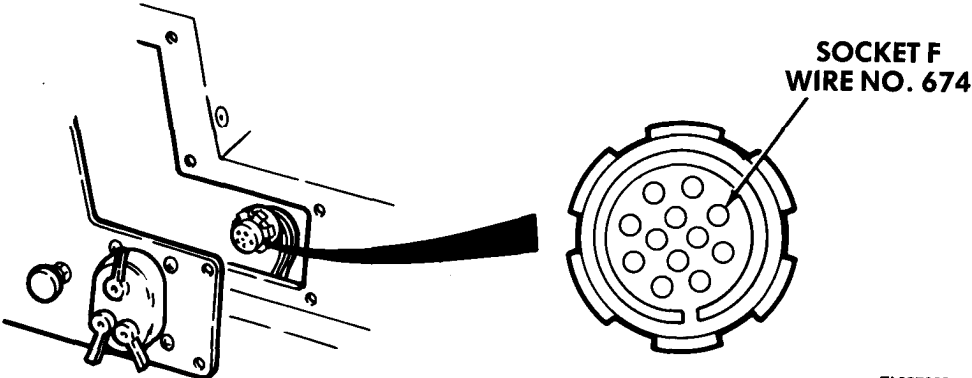
Troubleshooting Malfunctions (Cont)
Table 2-9. Troubleshooting (Cont)

| Malfunction Test or Inspection | Corrective Action |
|--|-------------------|
| ELECTRICAL SYSTEM (CONT) | |
| 8. AIR PRESSURE WARNING LIGHT AND BUZZER DO NOT WORK WHEN AIR PRESSURE DROPS BELOW APPROXIMATELY 65 PSI (448 kPa) (CONT). | |
| <p>The diagram illustrates the electrical components and their connections. On the left, a pressure switch is connected to wire No. 120. Below it is the brake treadle valve and the brake pedal. In the center is a buzzer with two terminals labeled 'TERMINAL NO. 4' and 'TERMINAL NO. 7'. On the right, a fuse block is shown with various wires connected to it. A thick black arrow points from the buzzer towards the fuse block.</p> | |
| TA357248 | |
| <p>Step 2. Check electrical leads at air pressure switches for looseness or damage. Tighten loose connections or replace damaged connection.</p> <p>Step 3. Check for continuity throughout buzzer and light wiring. Repair or replace defective wires or connectors.</p> | |
| NOTE | |
| <p>Disconnect wire 032 from terminal No. 4 on buzzer. This will remove low oil/high temperature circuit from buzzer.</p> | |
| <p>Step 4. Turn ENGINE switch ON. Remove wire 120 from top low air pressure switch and touch it to ground. If light and/or buzzer work, replace low air pressure switch(es) (para 11-11).</p> | |
| <p>Step 5. Check for 24 volts on terminal No. 7 of buzzer. If 24 volts are not present, trace wiring and find problem. Refer to FO-1, Electric Diagram. If 24 volts are present, replace buzzer (para 7-28).</p> | |

Troubleshooting Malfunctions (Cont)

2-15. TROUBLESHOOTING INSTRUCTIONS (CONT).

Table 2-9. Troubleshooting (Cont)

| Malfunction | Test or Inspection | Corrective Action |
|------------------------------------|---|---|
| ELECTRICAL SYSTEM (CONT) | | |
| 9. DOMELIGHT DOES NOT WORK. | | |
| | Step 1. Remove domelight lamp (para 7-70). Check for burned out lamp or damaged domelight. | Replace burned out lamp or damaged domelight (para 7-70). |
| | Step 2. Remove circuit breaker compartment cover (para 7-43). Check for 24 volts at input to circuit breaker No. 3 (fig. 2-2). | If 24 volts is not present, trace wiring and find problem. |
| | Step 3. Remove circuit breaker compartment cover, check for continuity across circuit breaker No. 3 terminals (fig. 2-2). | If no continuity, replace circuit breaker No. 3 (para 7-43). |
| | Step 4. Remove side panel (para 7-39), turn domelight switch on, check for continuity across domelight switch. | Replace defective switch (para 7-39). |
| | Step 5. Check domelight wiring for continuity. Refer to FO-1, Electric Diagram. | |
| |  | |
| | Step 6. Check for defective main light switch. Remove side panel and disconnect connector at main light switch. Check for 24 vdc on Socket F. | If 24 vdc is not present, trace wiring and find problem. Refer to FO-1, Electric Diagram. |
| | | If 24 vdc is present, replace main light switch (para 7-77). |
| | Step 7. If problem has not been solved, notify the supervisor. | |

TA357229

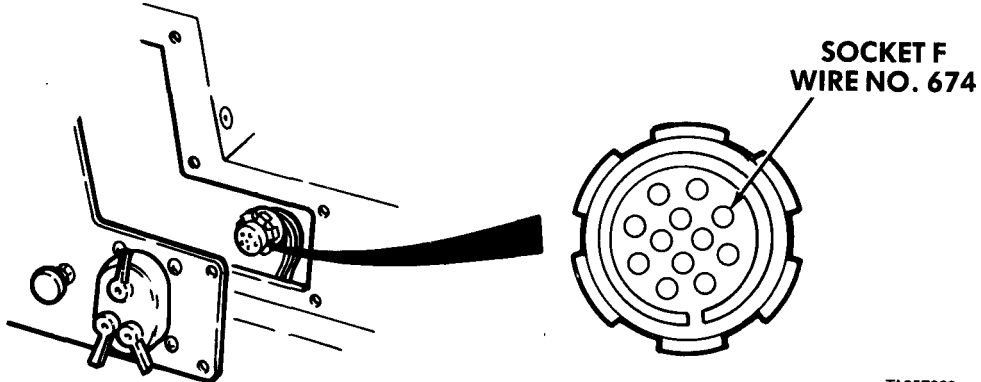
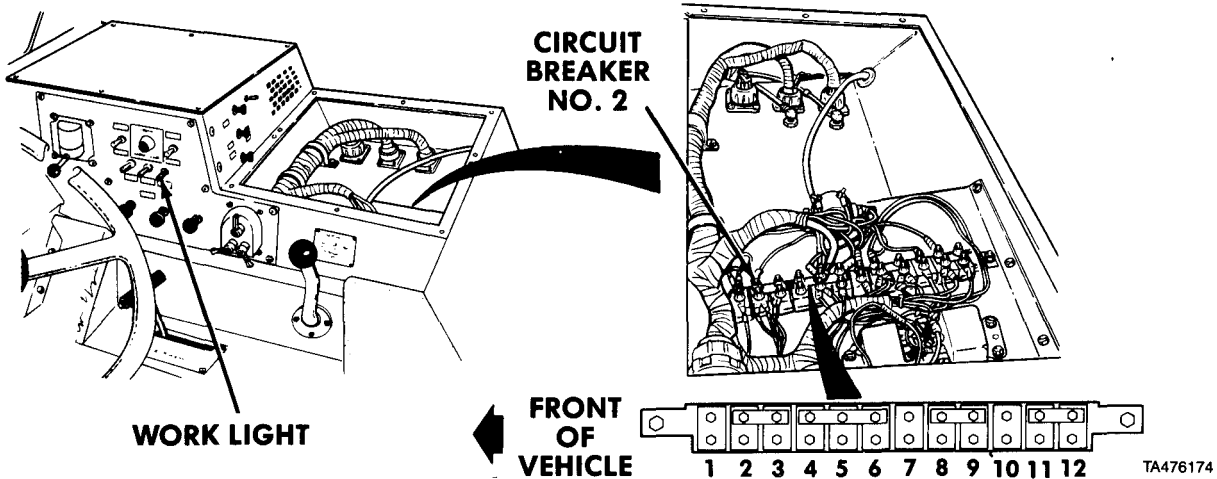
Troubleshooting Malfunctions (Cont)
Table 2-9. Troubleshooting (Cont)

| Malfunction | Test or Inspection | Corrective Action |
|---|---|--|
| ELECTRICAL SYSTEM (CONT) | | |
| 10. ENGINE STOP SWITCH DOES NOT ACTIVATE FUEL SHUTDOWN SOLENOID. | | |
| Step 1. | Disconnect batteries (para 7-91). Check ENGINE STOP switch for continuity when switch is pressed to STOP. | Replace defective switch (para 7-38). |
| Step 2. | Remove circuit breaker compartment cover (para 7-43). Check for 24 volts input at circuit breaker No. 5 (fig. 2-2). | If 24 volts is not present, repair wire between ignition switch and circuit breaker No. 5. |
| Step 3. | Remove heater compartment cover, check circuit breaker No. 5 for continuity (fig. 2-2). | Replace defective circuit breaker No. 5 (para 7-43). |
| Step 4. | Check fuel shutdown wiring circuit for continuity. Refer to FO-1, Electric Diagram. | Repair defective wire and broken connectors. |
| Step 5. | If problem has not been solved, notify the supervisor. | |
| 11. WORK LIGHTS DO NOT WORK (M983, M984). | | |
| Step 1. | Remove work lamp (para 7-71). Check for damaged or burned out work lamp. | Replace damaged or burned out work lamp (para 7-71). |
| Step 2. | Disconnect batteries (para 7-91). Remove heater compartment cover. Check circuit breaker No. 2 for continuity (fig. 2-2). | Replace defective circuit breaker No. 2 (para 7-43). |
| Step 3. | Remove side panel. Check work light switch for continuity. | Replace defective work light switch (para 7-39). |
| Step 4. | Check work light circuit wiring for continuity. Refer to FO-1, Electric Diagram. | Repair defective wire or broken connectors. |

Troubleshooting Malfunctions (Cont)

2-15. TROUBLESHOOTING INSTRUCTIONS (CONT).

Table 2-9. Troubleshooting (Cont)

| Malfunction | Test or Inspection | Corrective Action |
|--|--------------------|-------------------|
| ELECTRICAL SYSTEM (CONT) | | |
| 11. WORK LIGHTS DO NOT WORK (M983, M984) (CONT). | | |
|  | | |
| TA357229 | | |
| <p>Step 5. Check for defective main light switch. Remove side panel and disconnect connector at main light switch. Check for 24 vdc on Socket F.</p> | | |
| <p style="padding-left: 40px;">If 24 vdc is not present, trace wiring and find problem. Refer to FO-1, Electric Diagram.</p> | | |
| <p style="padding-left: 40px;">If 24 vdc is present, replace main light switch (para 7-77).</p> | | |
| 11.1. WORK LIGHTS DO NOT WORK (M984E1). | | |
|  | | |
| TA476174 | | |

Troubleshooting Malfunctions (Cont)
Table 2-9. Troubleshooting (Cont)

| Malfunction | Test or Inspection | Corrective Action |
|--|--|--|
| ELECTRICAL SYSTEM (CONT) | | |
| 11.1. WORK LIGHTS DO NOT WORK (M948E1) (CONT). | | |
| | Step 1. Remove work lamp (para 7-71). Check for damaged or burned out work lamp. | Replace damaged work lamp (para 7-71). Replace burned out lamp (para 7-71). |
| | Step 2. Disconnect batteries (para 7-91). Remove top panel. Check circuit breaker 2 for continuity. | Replace defective circuit breaker 2 (para 7-43). |
| | Step 3. Remove side panel. Check work light switch for continuity. | Replace defective work light switch (para 7-34). |
| | Step 4. Open electrical box cover (para 7-52.1). Check work light switch for continuity. | Replace defective work light switch (para 7-52.1). |
| | Step 5. Check work light circuit wiring for continuity (FO-1). | Repair defective wire or broken connectors. |
| 12. AIR DRYER CONSTANTLY EXHAUSTS AIR. | | |
| | Step 1. Check for broken wire or connector on air dryer. | Repair broken wire or connector. |
| | Step 2. Disconnect batteries (para 7-91). Remove heater compartment cover. Check circuit breaker No. 12 for continuity (fig. 2-2). | Replace defective circuit breaker (para 7-43). |
| NOTE | | |
| Air temperature must be below 40°F (5°C) in order for air dryer heater to operate. | | |
| | Step 3. Turn ENGINE switch ON. Check if air dryer end cover gets warm. | If air dryer end cover gets warm, replace purge valve (para 11-23). If air dryer end cover does not get warm, replace end cover (para 11-23). |
| | Step 4. Check for proper air governor adjustment. | Adjust air governor if not working properly. |
| | Step 5. If problem has not been solved, repair or replace air dryer (para 11-22, 11-23). | |

Troubleshooting Malfunctions (Cont)

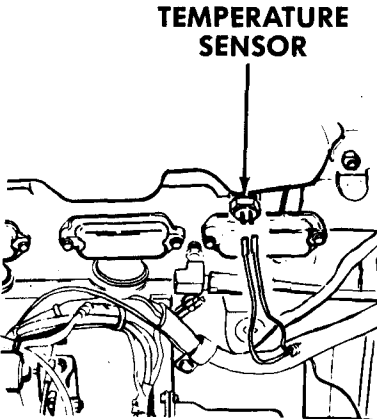
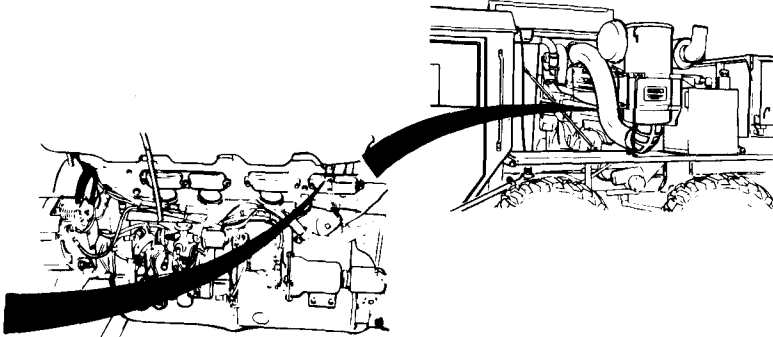
Table 2-9. Troubleshooting (Cont)

| Malfunction | Test or Inspection | Corrective Action |
|---|--|---|
| ELECTRICAL SYSTEM (CONT) | | |
| 13. MARKER AND CLEARANCE LIGHTS DO NOT WORK. | | |
| NOTE | | |
| If marker and clearance lights on vehicle are LED type, perform step (1.1). | | |
| Step 1. | Check for burned out or damaged marker and clearance light bulbs. | Replace burned out or damaged light bulbs (paras 7-66, 7-74). |
| Step 1.1. | Check for damaged or defective LED type marker and clearance lights. | Replace LED marker and clearance light (para 7-62). |
| Step 2. | Remove side panel. Check CL LPS light switch for continuity. | Replace defective CL LPS light switch (para 7-39). |
| Step 3. | Disconnect batteries (para 7-91). Remove top panel. Check circuit breaker No. 3 for continuity (fig. 2-2). | Replace defective circuit breaker No. 2 (para 7-43). |
| Step 4. | Check marker and clearance light circuits for continuity. Refer to FO-1, Electric Diagram. | Repair or replace broken wires or connectors. |
| | | |
| Step 5. | Check for defective main light switch. Disconnect connector at main light switch and check for 24 vdc on Socket F. | If 24 vdc is not present, trace wiring and find problem. Refer to FO-1, Electric Diagram. |
| | | If 24 vdc is present, replace main light switch (para 7-41). |
| Step 6. | If problem has not been solved, notify the supervisor. | |

Troubleshooting Malfunctions (Cont)

2-15. TROUBLESHOOTING INSTRUCTIONS (CONT).

Table 2-9. Troubleshooting (Cont)

| Malfunction | Test or Inspection | Corrective Action |
|--|--|--|
| ELECTRICAL SYSTEM (CONT) | | |
| 14. ETHER STARTING AID DOES NOT WORK. | | |
| | Step 1. Disconnect batteries (para 7-91). Remove instrument panel (para 7-19). Check ETHER START switch for continuity. | If no continuity, replace defective ETHER START switch (para 7-100). |
| | Step 2. Check for 24 vdc input at circuit breaker No. 11. | If 24 vdc is not present, trace wiring and find problem. Refer to FO-1, Electric Diagram. |
| | Step 3. Remove heater compartment cover. Check circuit breaker No. 11 for continuity (fig. 2-2). | If no continuity, replace defective circuit breaker No. 11 (para 7-43). |
| | Step 4. Check ether starting aid wiring circuit. | Repair broken wires or connectors. |
| |  <p style="text-align: center;">TEMPERATURE SENSOR</p> |  |
| | NOTE | |
| | Coolant temperature must be below 55°F (13°C) to activate ether injector system. | |
| | Step 5. Check ether starting aid injector valve with engine cold. Put jumper wire across two terminals on ether injector valve temperature sensor. Turn ENGINE switch ON, push ETHER START button. | If ether starting aid injector valve clicks, temperature sensor is bad. Notify the supervisor. |
| | If injector valve does not click, replace injector valve (para 4-12). | |

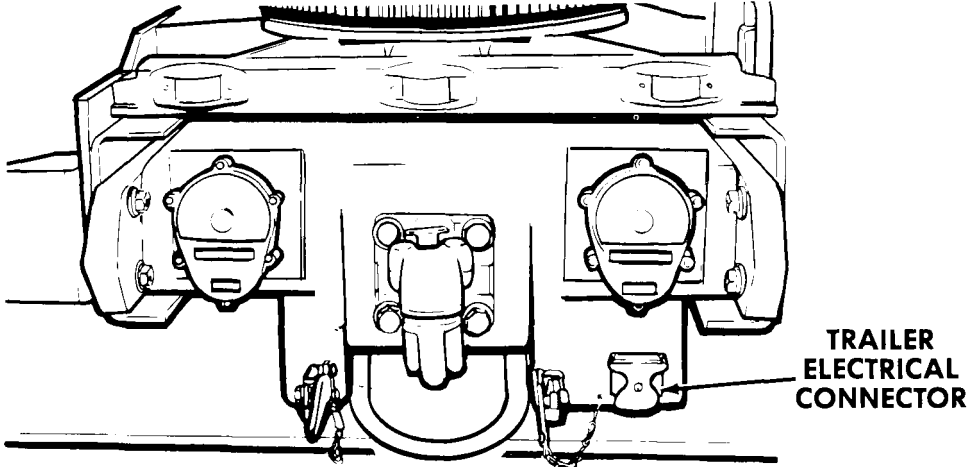
TA357249

Troubleshooting Malfunctions (Cont)
Table 2-9. Troubleshooting (Cont)

| Malfunction | Test or Inspection | Corrective Action |
|--|--|--|
| ELECTRICAL SYSTEM (CONT) | | |
| 15. ELECTRIC GAGES DO NOT WORK. | | |
| | Step 1. Disconnect batteries (para 7-91). Remove instrument panel (para 7-19). Check for loose or broken wire on gages. | Repair or replace wire. |
| | Step 2. Check gage for continuity. | Replace defective gage (go to Alphabetical Index to find gage replacement procedure). |
| | Step 3. Check sending unit as required. Remove wire from sending unit and touch to ground. If gage gives a reading, sending unit is bad. | Replace defective sending unit (go to Alphabetical Index to find sending unit replacement procedures). |
| 16. SWITCHES DO NOT WORK. | | |
| | Step 1. Check for loose or broken wires at switches. | Repair or replace wire or connection. |
| | Step 2. Disconnect batteries (para 7-91). Check switches for continuity. | Replace defective switch (go to Alphabetical Index to find switch replacement procedures). |

Troubleshooting Malfunctions (Cont)

Table 2-9. Troubleshooting (Cont)

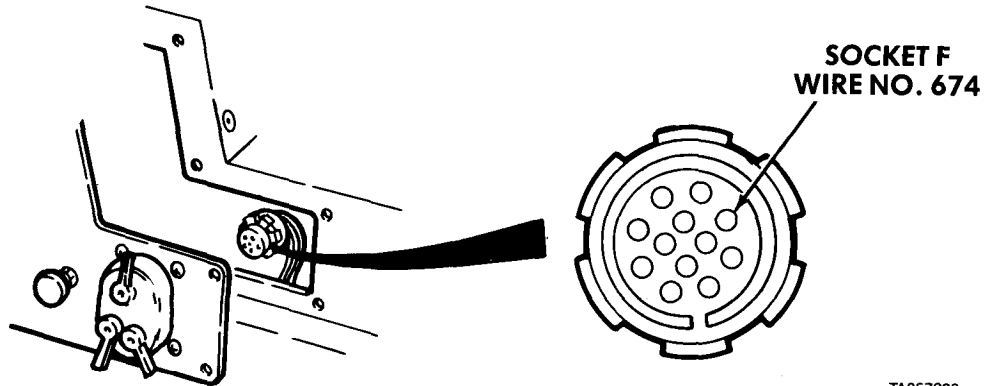
| Malfunction Test or Inspection | Corrective Action |
|---|---|
| ELECTRICAL SYSTEM (CONT) | |
| 17. TRAILER ELECTRICAL SYSTEM DOES NOT WORK. | |
|  <p>The diagram shows a top-down view of the rear of a trailer. It features a central hitch and two large circular light housings on either side. Below the hitch is the trailer electrical connector, which is a multi-pin plug. A label 'TRAILER ELECTRICAL CONNECTOR' with a leader line points to this component. Various wires and components are shown connected to the trailer's chassis.</p> | |
| <p>Step 1. Check for damaged connector.</p> | <p>Replace damaged connector.</p> |
| <p>Step 2. Disconnect batteries (para 7-91). Check chassis wiring harness for continuity. Refer to FO-1, Electric Diagram.</p> | <p>Repair broken wires and connections. If harness is defective, notify supervisor.</p> |
| 18. TURN SIGNALS DO NOT OPERATE. | |
| <p>NOTE If composite lights on vehicle are LED type, perform step (1.1).</p> | |
| <p>Step 1. Check for burned out or damaged light bulbs.</p> | <p>Replace damaged or burned out light bulbs (para 7-60).</p> |
| <p>Step 1.1. Check for damaged or defective LED composite lights.</p> | <p>Replace LED composite lights (para 7-62).</p> |
| <p>Step 2. Check turn signal wiring circuit for continuity. Refer to FO-1, Electric Diagram.</p> | <p>If continuity is not found in all wires, repair broken wires or connectors.</p> |
| <p>Step 3. Remove heater compartment cover, check for continuity across circuit breaker No. 1 terminals.</p> | <p>If no continuity is found, replace circuit breaker No. 1 (para 7-43).</p> |

Troubleshooting Malfunctions (Cont)
Table 2-9. Troubleshooting (Cont)

| Malfunction | Test or Inspection | Corrective Action |
|-------------|--------------------|-------------------|
|-------------|--------------------|-------------------|

ELECTRICAL SYSTEM (CONT)

18. TURN SIGNALS DO NOT OPERATE (CONT).



TA357229

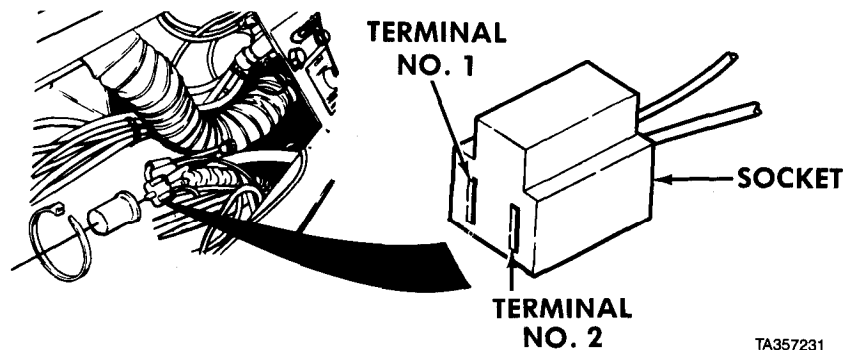
Step 4. Check for defective main light switch. Disconnect connector at main light switch and check for 24 vdc on Socket F.

If voltage is not 24 vdc, trace wiring and find problem. Refer to FO-1, Electric Diagram.

If voltage is 24 vdc, go to Step 5.

Step 5. Check for 24 vdc at input terminal 080 on circuit breaker No. 1.

If voltage is not 24 vdc, replace main light switch (para 7-41).



TA357231

Step 6. Check for defective flasher relay. Remove flasher relay from socket (para 7-51) and install a jumper wire between terminal No. 1 and No. 2. Turn main light switch to Service Drive position. Turn emergency flashers ON. Check that all lights turn on and remain on.

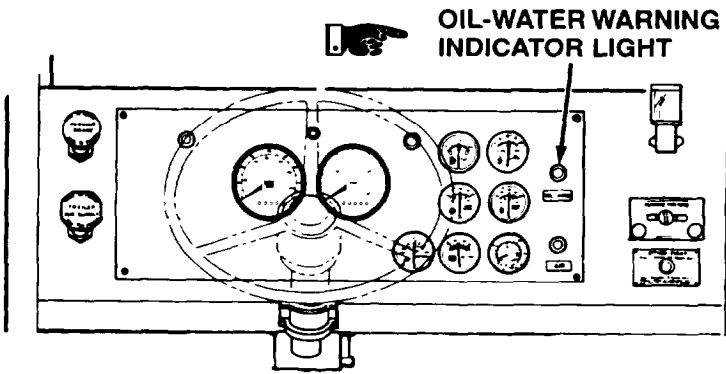
If all lights operate, replace defective flasher relay (para 7-51).

If all lights do not operate, replace defective turn signal switch (para 7-50).

Troubleshooting Malfunctions (Cont)

2-15. TROUBLESHOOTING INSTRUCTIONS (CONT). 1

Table 2-9. Troubleshooting (Cont)

| Malfunction | Test or Inspection | Corrective Action |
|---|--|--|
| ELECTRICAL SYSTEM (CONT) | | |
| <p>19. OIL-WATER INDICATOR AND BUZZER DO NOT WORK WHEN OIL PRESSURE DROPS BELOW 8 PSI (55 KPA).</p> |  <p>The diagram shows a rectangular control panel with a central circular gauge cluster. To the left are two indicator lights. To the right are several smaller gauges and indicator lights. A hand icon points to a light on the right side, which is labeled 'OIL-WATER WARNING INDICATOR LIGHT'.</p> | |
| <p>Step 1.</p> | <p>Check for burned out oil-water warning indicator light.</p> | <p>Remove lamp (para 7-31) and replace lamp if burned out.</p> |

Troubleshooting Malfunctions (Cont)

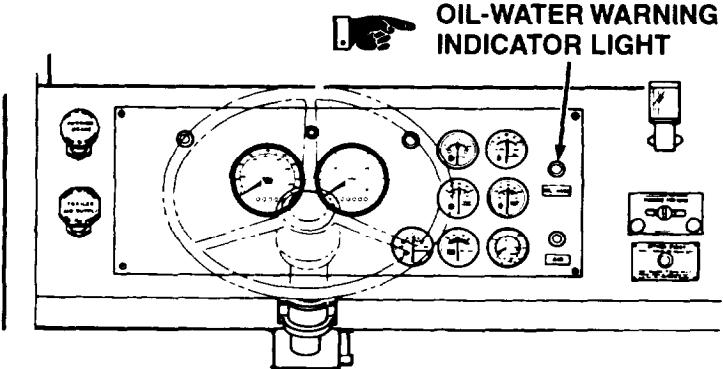
Table 2-9. Troubleshooting (Cont)

| Malfunction | Test or Inspection | Corrective Action |
|--|--|-------------------|
| ELECTRICAL SYSTEM (CONT) | | |
| <p>19. OIL-WATER INDICATOR AND BUZZER DO NOT WORK WHEN OIL PRESSURE DROPS BELOW 8 PSI (55 KPA) (CONT).</p> | | |
| | | |
| Step 2. | <p>Check electrical leads at low oil pressure switch for looseness or damage. Tighten loose connections or replace damaged connection.</p> | |
| Step 3. | <p>Check for continuity throughout buzzer and light wiring. Repair or replace defective wires or connectors.</p> | |
| NOTE | | |
| <p>Disconnect wire No. 120 from terminal No. 5 on buzzer. This will remove low air pressure circuit from buzzer.</p> | | |
| Step 4. | <p>Turn ENGINE switch ON. Remove wire No. 147 from low oil pressure switch and touch it to ground. If light and/or buzzer work, replace low oil pressure switch (para 7-84).</p> | |
| Step 5. | <p>If buzzer does not work, check for 24 volts on terminal No. 7 of buzzer. If 24 volts are not present, trace wiring and correct problem. Refer to FO-1, Electrical Schematic. If 24 volts are present, replace buzzer (para 7-28).</p> | |

Troubleshooting Malfunctions (Cont)

2-15. TROUBLESHOOTING INSTRUCTIONS (CONT).

Table 2-9. Troubleshooting (Cont)

| Malfunction | Test or Inspection | Corrective Action |
|--|---|---|
| ELECTRICAL SYSTEM (CONT) | | |
| 20. OIL-WATER INDICATOR AND BUZZER DO NOT WORK WHEN COOLANT TEMPERATURE RISES ABOVE 230° F (110° C). |  A technical diagram of a control panel. It features a central circular gauge with two sub-gauges. To the left are two indicator lights. To the right are several smaller gauges and switches. A hand icon points to a specific light on the right side of the panel, which is labeled 'OIL-WATER WARNING INDICATOR LIGHT' with a leader line. | |
| Step 1. | Check for burned out oil-water warning indicator light. | Remove lamp (para 7-31) and replace lamp if burned out. |

Troubleshooting Malfunctions (Cont)

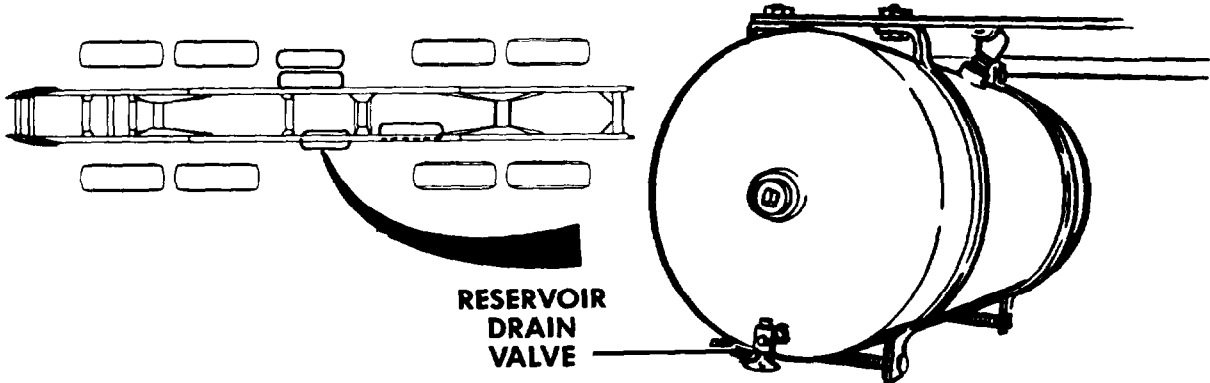
Table 2-9. Troubleshooting (Cont)

| Malfunction | Test or Inspection | Corrective Action |
|--|--|---|
| ELECTRICAL SYSTEM (CONT) | | |
| 20. OIL-WATER INDICATOR AND BUZZER DO NOT WORK WHEN COOLANT TEMPERATURE RISES ABOVE 230° F (110° C) (CONT). | | |
| | | |
| Step 2 | Check electrical leads at high water temperature switch for looseness or damage. | Tighten loose connections or replace damaged connection. |
| Step 3. | Check for continuity throughout buzzer and light wiring. | Repair or replace defective wires or connectors. |
| NOTE | | |
| Disconnect wire No. 120 from terminal No. 5 on buzzer. This will remove low air pressure circuit from buzzer. | | |
| Step 4. | Turn ENGINE switch ON. Remove wire No. 32 from high water temperature switch and touch it to ground. | If light and/or buzzer work, replace high water temperature switch (para 7-78). |
| Step 5. | If buzzer does not work, check for 24 volts on terminal No. 7 of buzzer. | If 24 volts are not present, trace wiring and correct problem. Refer to FO-1, Electrical Schematic. |
| If 24 volts are present, replace buzzer (para 7-28). | | |

Troubleshooting Malfunctions (Cont)

2-15. TROUBLESHOOTING INSTRUCTIONS (CONT).

Table 2-9. Troubleshooting (Cont)

| Malfunction | Test or Inspection | Corrective Action |
|--|---|-------------------|
| AIR SYSTEM | | |
| <u>WARNING</u> | | |
| <p>Make sure reservoirs have been drained before doing any work on air system components. Sudden release of air pressure from valves, hoses, and other air system components can cause serious injury.</p> | | |
| <p>AIR PRESSURE BUILDUP SLOW.</p> | | |
|  <p>The diagram illustrates an air system component. On the left, a horizontal air line with several outlets is shown. A curved line connects this line to a large cylindrical reservoir on the right. A small valve at the bottom of the reservoir is labeled "RESERVOIR DRAIN VALVE".</p> | | |
| Step 1. | <p>Check reservoir drain valve to see if it is open or leaking. Close or replace drain valve (para 11-30).</p> | |
| Step 2. | <p>Check air lines, connections, and air system components for leaks or damage. Tighten loose connections. Replace leaking air lines and connectors (para 11-35) or components (go to Alphabetical Index to find component replacement procedures).</p> | |

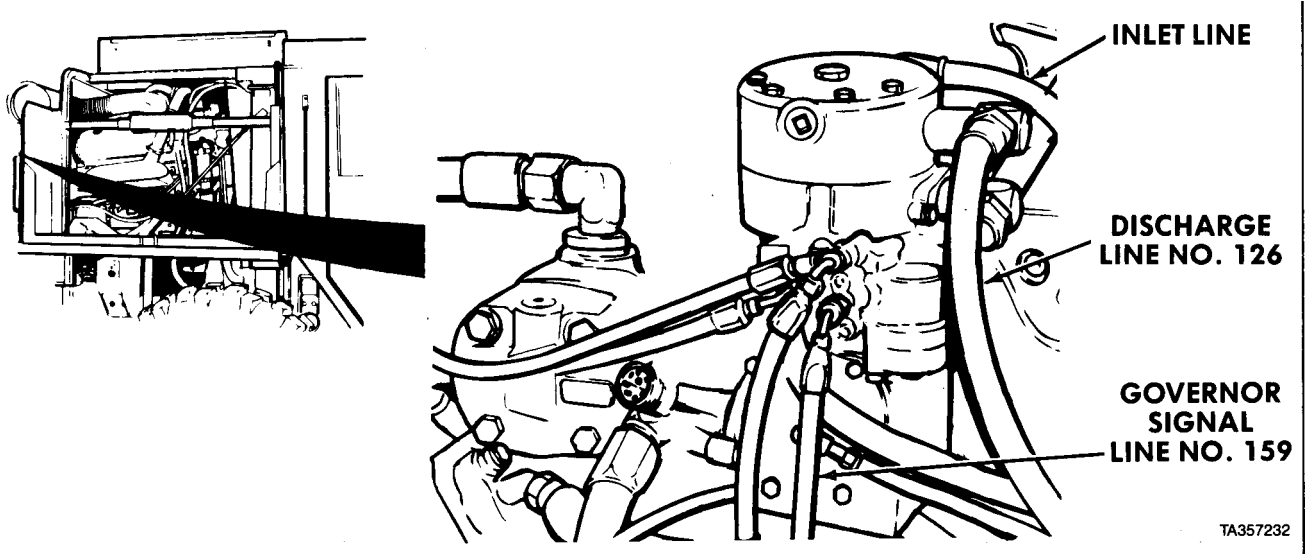
Troubleshooting Malfunctions (Cont)

Table 2-9. **Troubleshooting (Cont)**

| | |
|--------------------|-------------------|
| Malfunction | |
| Test or Inspection | Corrective Action |

AIR SYSTEM (CONT)

1. AIR PRESSURE BUILDUP SLOW (CONT).



Step 3. Check for restricted air compressor inlet line.

Remove kinks or restrictions in air inlet line. Replace lines if necessary.

Step 4. Check for restricted air compressor discharge line.

Remove kinks or restriction in discharge line. Replace discharge line if necessary.

Step 5. Drain air system. Disconnect governor signal line No. 159 from air governor. Disconnect air discharge line No. 126 from air compressor. Start engine and check for air flow out of compressor discharge port.

If little or no air comes from discharge port, replace air compressor (para 11-38).

If a large amount of air comes from discharge port, go to Step 6.

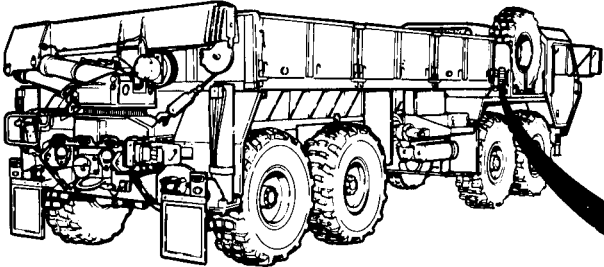
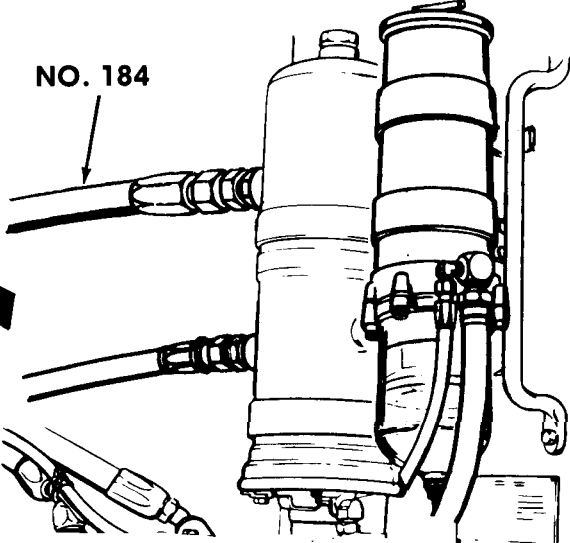
Step 6. Check for correct air governor operation and adjustment (para 11-36).

If air governor does not operate correctly or cannot be adjusted, replace air governor (para 11-37).

Troubleshooting Malfunctions (Cont)

2-15. TROUBLESHOOTING INSTRUCTIONS (CONT).

Table 2-9. Troubleshooting (Cont)

| Malfunction | Test or Inspection | Corrective Action |
|---|---|-------------------|
| AIR SYSTEM (CONT) | | |
| 1. AIR PRESSURE BUILDUP SLOW (CONT). | | |
|  |  | |
| Step 7. Drain air pressure. Remove air dryer discharge line No. 184. Start engine and build air pressure. Check air flow from air dryer discharge port. | | |
| If little or no air comes from discharge port, service air dryer and check for restricted air dryer outlet check valve (para 11-22, 11-23). | | |
| If a large amount of air comes from discharge port, go to Step 8. | | |

Troubleshooting Malfunctions (Cont)

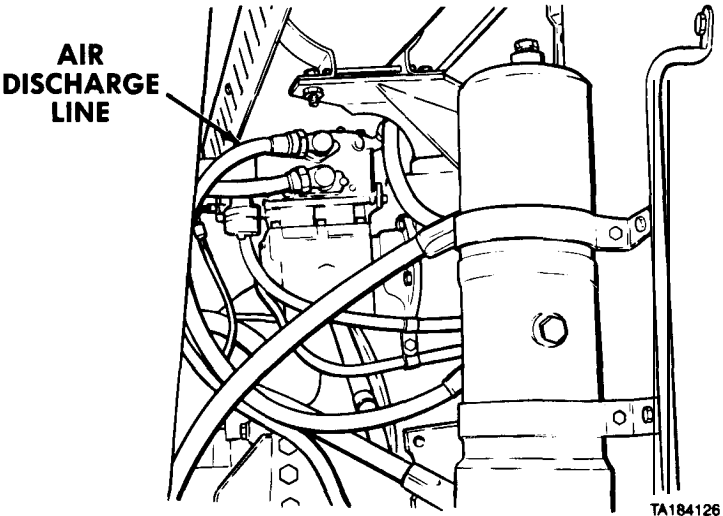
Table 2-9. Troubleshooting (Cont)

| Malfunction | Test or Inspection | Corrective Action |
|---|--------------------|-------------------|
| AIR SYSTEM (CONT) | | |
| 1. AIR PRESSURE BUILDUP SLOW (CONT). | | |
| | | |
| <p>Step 8. Drain air system. Remove and inspect air inlet check valves at air reservoirs No. 2 and No. 3 (paras 11-30, 11-31).</p> | | |
| <p style="padding-left: 40px;">Replace damaged air inlet check valves (paras 11-30, 11-31).</p> | | |
| <p style="padding-left: 40px;">If no damage is found, replace pressure protection valve at air reservoir No. 1 (para 11-29). If problem has not been solved, notify the supervisor.</p> | | |
| 2. MOISTURE IN AIR SYSTEM. | | |
| <p>Step 1. Check to see that air dryer exhausts when air pressure reaches 120 to 128 psi (827 to 883 kPa).</p> | | |
| <p style="padding-left: 40px;">If air dryer exhausts, service air dryer (para 11-22).</p> | | |
| <p style="padding-left: 40px;">If it does not exhaust, replace air dryer (para 11-23).</p> | | |
| 3. COMPRESSOR FAILS TO UNLOAD. | | |
| <p>Step 1. Check for restricted governor air inlet line.</p> | | |
| <p style="padding-left: 40px;">Remove line and clear restriction or replace kinked line.</p> | | |
| <p>Step 2. Check for governor out of adjustment (para 11-36).</p> | | |
| <p style="padding-left: 40px;">Adjust governor (para 11-36).</p> | | |
| <p style="padding-left: 40px;">If governor will not adjust, replace governor (para 11-37).</p> | | |

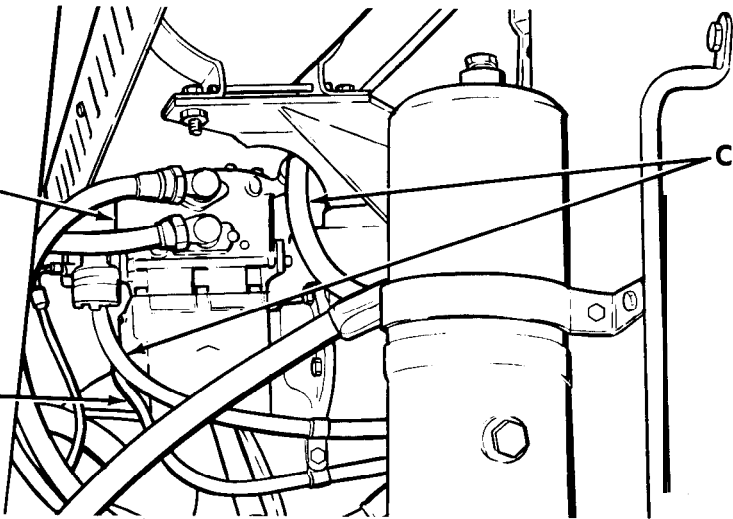
Troubleshooting Malfunctions (Cont)

12-15. TROUBLESHOOTING INSTRUCTIONS (CONT).

Table 2-9. Troubleshooting (Cont)

| Malfunction Test or Inspection | Corrective Action |
|---|-------------------|
| <p>AIR SYSTEM (CONT)</p> | |
| <p>4. NOISY COMPRESSOR OPERATION.</p> | |
|  <p style="text-align: right; font-size: small;">TA184126</p> | |
| <p>Step 1. Check air discharge line for kinks and restrictions. Remove line and clear restriction or replace air discharge line (para 11-23).</p> | |
| <p>Step 2. If problem has not been solved, replace compressor (para 11-38).</p> | |
| <p>5. COMPRESSOR CYCLES CONSTANTLY.</p> | |
| <p>Step 1. Check connections, lines, and components for leaks. Tighten loose connections and repair leaking lines (para 11-23). Replace components as necessary (go to Alphabetical Index to find component replacement procedure).</p> | |
| <p>Step 2. Check for defective governor. Adjust governor (para 11-36). If governor cannot be adjusted, replace governor (para 11-37).</p> | |

Troubleshooting Malfunctions (Cont)
 Table 2-9. Troubleshooting (Cont)

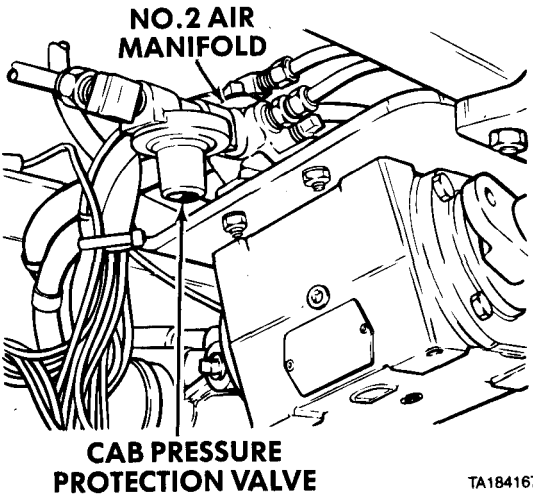
| Malfunction | Test or Inspection | Corrective Action |
|--|---|---|
| AIR SYSTEM (CONT) | | |
| 6. AIR PRESSURE DROPS RAPIDLY AFTER ENGINE SHUTDOWN. | Step 1. Check connections, lines, and components for leaks. | If connections or lines are leaking, tighten connections and repair leaking lines (para 11-35). If components are leaking, replace leaking components (go to Alphabetical Index to find component replacement procedures). |
| | Step 2. Check for leaking air reservoirs. | If air reservoirs are leaking, replace leaking reservoir (paras 11-29 through 11-33). |
| 7. COMPRESSOR LEAKS OIL OR COOLANT. | | |
|  | | |
| | Step 1. Check for damaged or loose oil lines and fittings, and damaged or loose coolant line fittings. | Tighten or replace oil lines or coolant plugs and fittings as necessary. |
| | Step 2. Check for damaged compressor. | Replace damaged compressor (para 11-38). |

TA183998

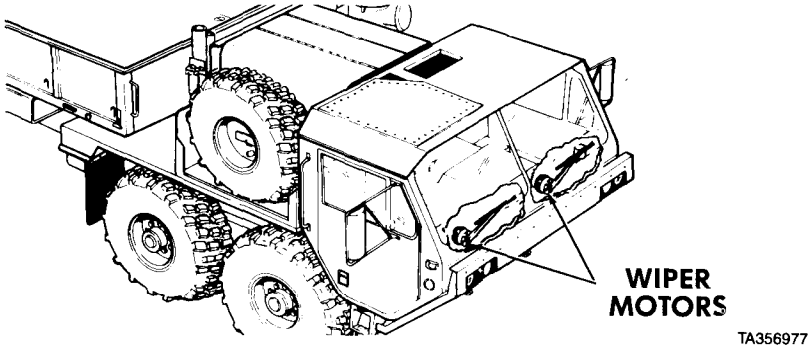
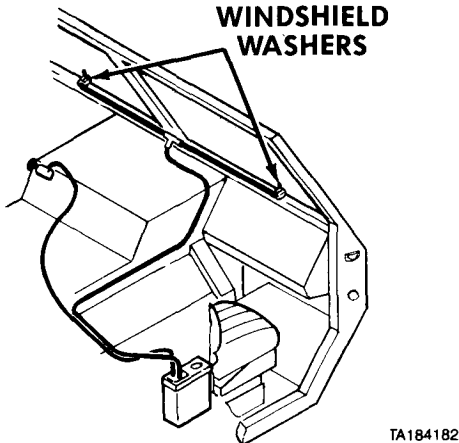
Troubleshooting Malfunctions (Cont)

12-15. TROUBLESHOOTING INSTRUCTIONS (CONT).

Table 2-9. Troubleshooting (Cont)

| Malfunction | Test or Inspection | Corrective Action |
|--|--|---|
| AIR SYSTEM (CONT) | | |
| 8. CHECK VALVE FAILS TO RELEASE SYSTEM PRESSURE AT 150 PSI (1 034 kPa). | <p>Step 1. Replace check valve (para 11-23) and adjust governor (para 11-36).</p> | <p>If governor cannot be adjusted replace governor (para 11-37),</p> |
| 9. AIR SYSTEM PRESSURE BUILDS UP TO MORE THAN 130 PSI (896 kPa). | <p>Step 1. Check for governor out of adjustment (para 11-36).</p> | <p>If governor is out of adjustment, adjust governor (para 11-36). If governor cannot be adjusted, replace governor (para 11-37).</p> |
| 10. LEFT OR RIGHT WINDSHIELD WIPER DOES NOT WORK. |  | |
| NOTE | | |
| <p>Wipers will not operate unless air pressure is above 60 to 70 psi (414 to 483 kPa).</p> | | |
| <p>Step 1. Check cab air supply at pressure protection valve inlet port.</p> | <p>Pressure protection valve opens to supply air out at 60 to 70 psi (414 to 483 kPa). If pressure protection valve does not open, replace defective pressure protection valve (para 11-16).</p> | |
| <p>Step 2. Check for leaking or defective airhoses.</p> | <p>Tighten loose connections or repair damaged airhoses.</p> | |

Troubleshooting Malfunctions (Cont)
 Table 2-9. Troubleshooting (Cont)

| Malfunction | Test or Inspection | Corrective Action |
|--|--------------------|-------------------|
| AIR SYSTEM (CONT) | | |
| 10. LEFT OR RIGHT WINDSHIELD WIPER DOES NOT WORK (CONT). | | |
|  | | |
| <p>Step 3. Check air supply in and out of wiper control valve. If there is air supply in, but does not come out, replace defective wiper control valve (para 18-9).</p> | | |
| <p>Step 4. Check air supply to windshield wiper motor. If there is air supply to windshield wiper motor, replace windshield wiper motor (para 18-3).</p> | | |
| 11. WINDSHIELD WASHER DOES NOT WORK. | | |
|  | | |
| <p>Step 1. Check for loose connections at windshield washers. If connections are loose, tighten connections.</p> | | |

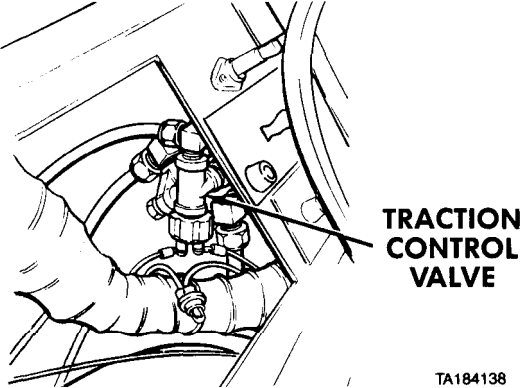
Troubleshooting Malfunctions (Cont)

2-15. TROUBLESHOOTING INSTRUCTIONS (CONT).

Table 2-9. Troubleshooting (Cont)

| Malfunction | Test or Inspection | Corrective Action |
|---|--|---|
| AIR SYSTEM (CONT) | | |
| 11. WINDSHIELD WASHER DOES NOT WORK (CONT). | Step 2. Check for defective cab pressure protection valve (go to MALFUNCTION 10, LEFT OR RIGHT WINDSHIELD WIPER DOES NOT WORK, Step 1, then come back to Step 3). | |
| | Step 3. Check windshield washer control valve for air supply in and air supply out when windshield washer control valve is operated. | If windshield washer control valve has air supply in, but not out, replace defective windshield washer control valve (para 18-8). |
| | Step 4. Check for leaking, plugged, or damaged air lines. | Remove restriction and repair damaged airhoses. |
| 12. AIR HORN DOES NOT WORK. | Step 1. Check air horns for loose connections or damage. | Tighten loose connections, replace damaged air horn (para 18-7). |
| | Step 2. Check air horn control valve for loose connections or damage. | Tighten loose connections, replace damaged air horn control valve (para 18-6). |
| | Step 3. Check for defective pressure protection valve (go to MALFUNCTION 10, LEFT OR RIGHT WINDSHIELD WIPER DOES NOT WORK, Step 1). | Replace defective pressure protection valve (para 11-16). |
| <u>WARNING</u> | | |
| Compressed air used for cleaning purposes will not exceed 30 psi (207 kPa). Use only with effective chip guarding and personal protective equipment, goggles, shield, and gloves. | | |
| | Step 4. Check air horn control valve. Remove air horn control valve (para 18-6). Blow low pressure compressed air into air horn control valve with control valve lever actuated. | If air does not flow through air horn control valve, replace air horn control valve (para 18-6). |
| | | If air flows through valve, replace defective air horns (para 18-7). |

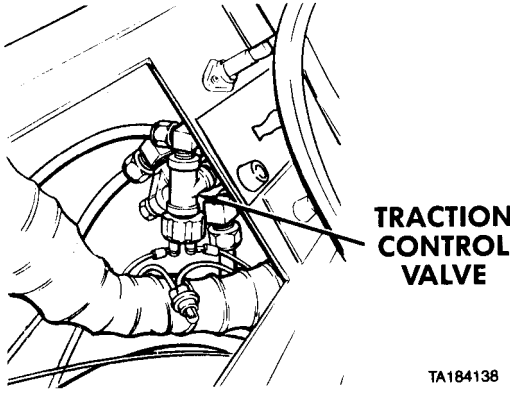
Troubleshooting Malfunctions (Cont)
Table 2-9. *Troubleshooting* (Cont)

| Malfunction | Test or Inspection | Corrective Action |
|---|--------------------|-------------------|
| AIR SYSTEM (CONT) | | |
| 13. AXLES WILL NOT LOCK UP. | | |
|  | | |
| <p>Step 1. Check for air leaks at TRACTION CONTROL valve. Tighten loose connections or repair lines.</p> <p>Step 2. Check for damaged or leaking lines to TRACTION CONTROL valve and air chambers. Tighten or replace damaged or leaking lines.</p> <p>Step 3. Check for defective pressure protection valve (go to MALFUNCTION 10, LEFT OR RIGHT WINDSHIELD WIPER DOES NOT WORK, Step 1). Replace defective pressure protection valve (para 11-16).</p> <p>Step 4. Check for air leaks at air chambers on No. 2 and No. 3 axles. Tighten loose connection.</p> <p>Step 5. Remove instrument panel (para 7-19). Check TRACTION CONTROL valve for air supply when TRACTION CONTROL valve is operated. If TRACTION CONTROL valve has air in but not air out when TRACTION CONTROL valve is operated, replace defective TRACTION CONTROL valve (para 9-7).</p> <p>Step 6. If problem has not been solved, notify the supervisor.</p> | | |

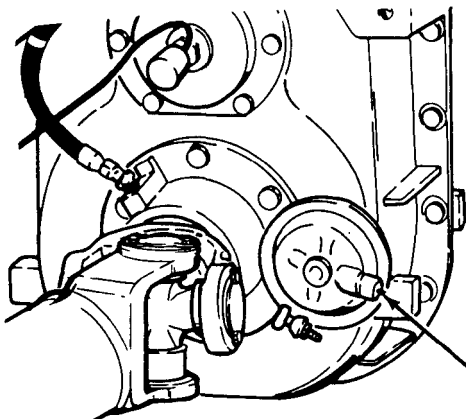
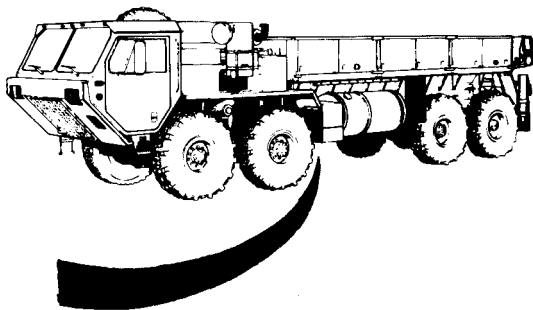
Troubleshooting Malfunctions (Cont)

2-15. TROUBLESHOOTING INSTRUCTIONS (CONT).

Table 2-9. Troubleshooting (Cont)

| Malfunction Test or Inspection | Corrective Action |
|--|-------------------|
| <p>AIR SYSTEM (CONT)</p> | |
| <p>14. TRANSFER CASE WILL NOT LOCK UP.</p> | |
| <p>Step 1. Check HI-LO Range valve for loose or damaged connections and adjustment. Tighten connections, adjust, or replace HI-LO Range valve (para 9-6).</p> | |
|  <p>TA184138</p> | |
| <p>Step 2. Check for damaged air lines to HI-LO Range valve, TRACTION CONTROL valve, and transfer case lockup chamber. Repair or replace damaged lines.</p> | |
| <p>Step 3. Check cab air supply at pressure protection valve inlet port. Pressure protection valve opens to supply air out at 60 to 70 psi (414 to 483 kPa). If pressure protection valve does not open, replace defective pressure protection valve (para 11-16).</p> | |
| <p>Step 4. Remove instrument panel (para 7-19). Check TRACTION CONTROL valve for air supply when valve is operated. If TRACTION CONTROL valve has air in but not air out when TRACTION CONTROL valve is operated, replace defective TRACTION CONTROL valve (para 9-7).</p> | |

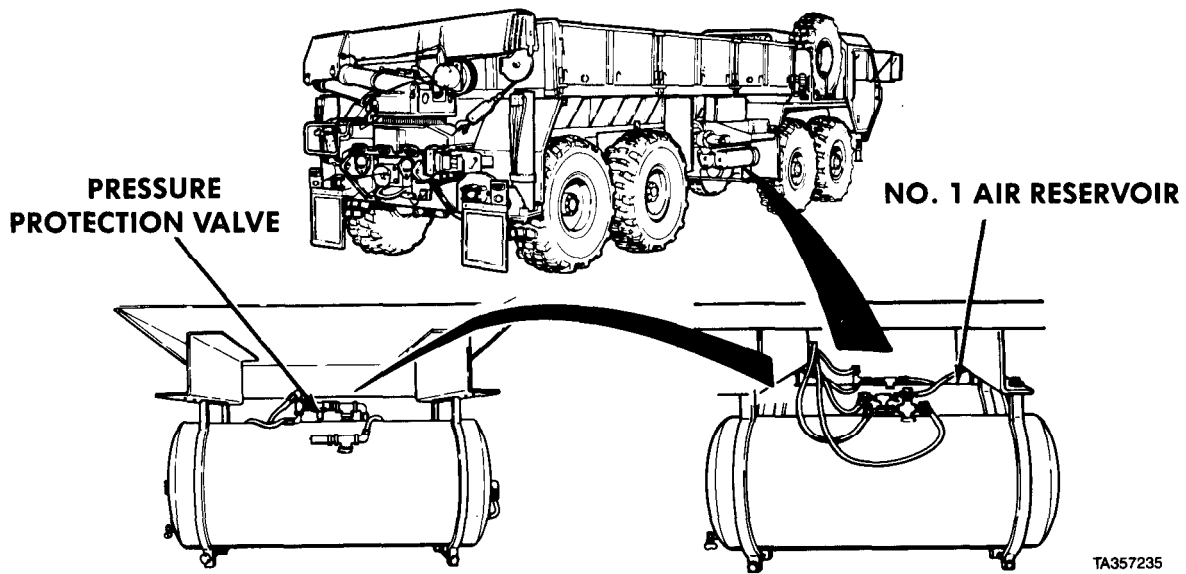
Troubleshooting Malfunctions (Cont)
 Table 2-9. Troubleshooting (Cont)

| Malfunction | Test or Inspection | Corrective Action |
|--|--|---------------------|
| AIR SYSTEM (CONT) | | |
| 14. TRANSFER CASE WILL NOT LOCK UP (CONT). | | |
|  |  | AIR LINE |
| TA184826 | | |
| Step 5. Check transfer case lockup chamber for loose connections or damage. | | |
| Tighten loose connections. | | |
| Step 6. If transfer case lockup chamber is damaged or if problem has not been solved, notify the supervisor. | | |

Troubleshooting Malfunctions (Cont)

2-15. TROUBLESHOOTING INSTRUCTIONS (CONT).

Table 2-9. Troubleshooting (Cont)

| Malfunction | Test or Inspection | Corrective Action |
|--------------------------|---|--|
| AIR SYSTEM (CONT) | | |
| 15. | THROTTLE TREADLE ACCELERATES ENGINE BUT NO AIR PRESSURE IN REMAINDER OF AIR SYSTEM. |  <p style="text-align: right;">TA357235</p> |
| | <p>Step 1. Check for loose or damaged air lines from No. 1 air reservoir to all systems. Tighten loose air line fittings and repair damaged air lines.</p> | |
| | <p>Step 2. Remove output line from pressure protection valve at No. 1 air reservoir. Start engine (TM 9-2320-279-10), wait until air dryer exhausts. If air does not come out of pressure protection valve, replace pressure protection valve (para 11-29).</p> | |

Troubleshooting Malfunctions (Cont)
 Table 2-9. Troubleshooting (Cont)

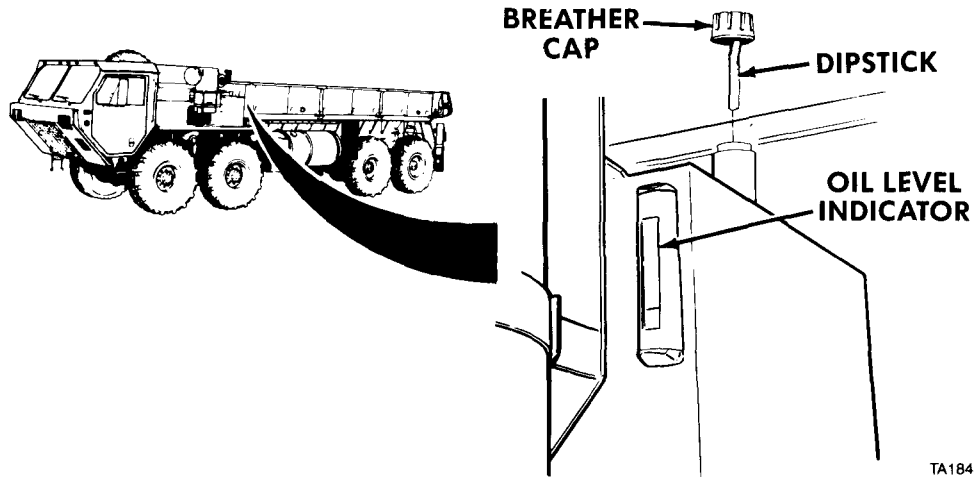
Malfunction

Test or Inspection

Corrective Action

STEERING SYSTEM

1. HARD TO STEER.



TA184190

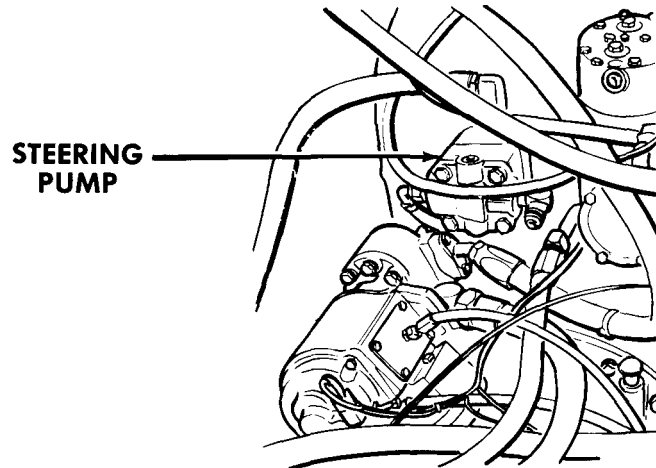
Step 1. Check hydraulic oil level (LO 9-2320-279-12).

If hydraulic oil level is low, add oil (LO 9-2320-279-12).

Step 2. Check hose and fittings for leaks or damage.

Tighten loose fittings. Replace damaged lines and fittings.

Add oil as necessary (LO 9-2320-279-12).



TA184145

Step 3. Check steering pump for leaks, loose mounting, and noise.

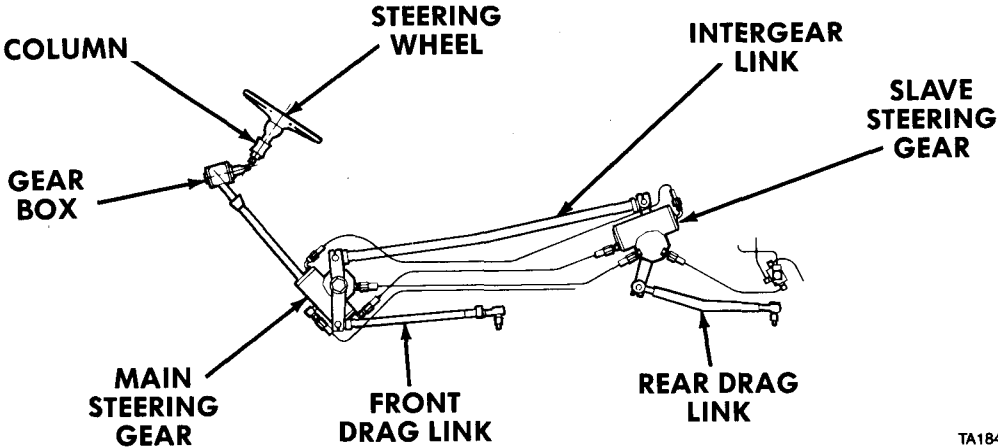
Tighten loose hose lines to pump or loose steering pump mounting.

If steering pump is making noise, notify the supervisor.

Troubleshooting Malfunctions (Cont)

2-15. TROUBLESHOOTING INSTRUCTIONS (CONT).

Table 2-9. Troubleshooting (Cont)

| Malfunction | Test or Inspection | Corrective Action |
|---|---|--|
| STEERING SYSTEM (CONT) | | |
| 1. HARD TO STEER (CONT). | <p>Step 4. Check main steering gear and secondary (slave) steering gear for leaks, loose mountings, or damage.</p> | <p>Tighten loose mountings and add oil as necessary (LO 9-2320-279-12). If there are leaks or damage to steering gears, notify the supervisor.</p>  <p style="text-align: right; font-size: small;">TA184133</p> <p>Step 5. Check that all steering linkage, including drag links, pitman arms, steering arms, intergear link, and tie rods are lubricated and are not loose or damaged.</p> <p>Lubricate as required (LO 9-2320-279-12). Tighten if loose or replace drag links (para 13-4), tie rods (para 13-5), or steering arm (para 10-4) if damaged.</p> <p>Step 6. Check steering gearbox and steering column for loose mounting or damage.</p> <p>Tighten loose mounting. If damaged, notify the supervisor.</p> |
| 2. WANDERS OR PULLS TO ONE SIDE. | <p>Step 1. Check for uneven tire pressure, especially at front tandem.</p> <p>Step 2. Check wheels for loose lugnuts.</p> | <p>Inflate tires (TM 9-2320-279-10). Tighten loose lugnuts (TM 9-2320-279-10).</p> |

Troubleshooting Malfunctions (Cont)

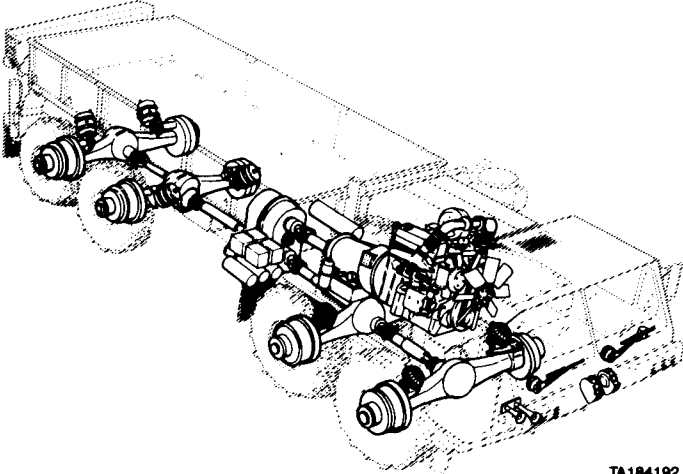
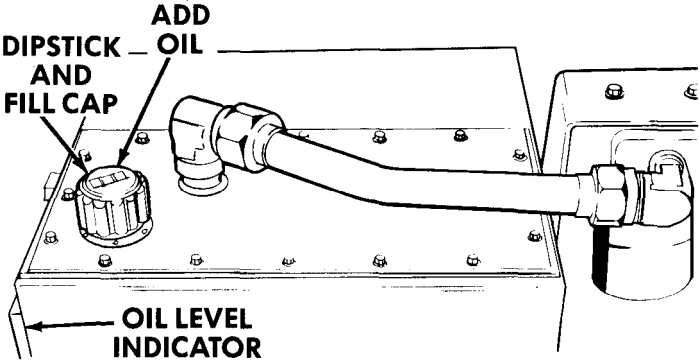
Table 2-9. Troubleshooting (Cont)

| Malfunction | Test or Inspection | Corrective Action |
|---|---|--|
| STEERING SYSTEM (CONT) | | |
| 2. WANDERS OR PULLS TO ONE SIDE (CONT). | Step 3. Check for brake dragging. Jack up vehicle (TM 9-2320-279-10) and turn wheels. | If brakes drag, adjust brakes (para 11-7) or replace brake shoes (paras 11-3 or 11-4). |
| Step 4. Check for loose or damaged wheel bearings. | Adjust wheel bearings (para 12-2 or 12-3). | Replace if damaged (para 12-2 or 12-3). |
| | Lubricate wheel bearings as required (LO 9-2320-279-12). | |
| Step 5. Check main steering gear and secondary (slave steering gear) for loose mounting. | If mounting is loose, tighten the main steering gear mounting screws to 155 lb-ft (210 N ^o m). Tighten the slave steering gear screws to 155 lb-ft (210 N ^o m). | |
| | <p>The diagram illustrates the front steering assembly of a vehicle. It shows the main steering gear connected to the steering knuckle. A slave steering gear is also shown, connected to the tie rods. The tie rods are connected to the drag link. Hand icons point to the main steering gear, tie rods, and slave steering gear.</p> | |
| Step 6. Check drag link and tie rods for damage or loose ends. | Tighten loose drag links or tie rod ends. Replace damaged drag links (para 13-4) or tie rod ends (para 13-5). | |
| Step 7. Check shock absorbers and leaf spring assemblies for loose mounting and broken parts. | Tighten loose mountings or replace broken shock absorbers (para 15-2). | |
| | If leaf spring assemblies are damaged, notify the supervisor. | |

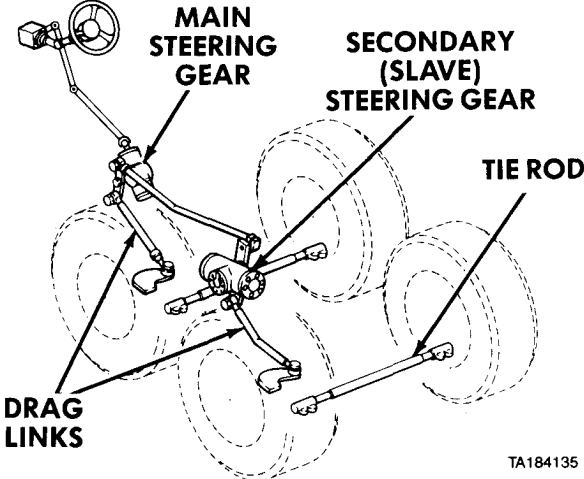
Troubleshooting Malfunctions (Cont)

2-15. TROUBLESHOOTING INSTRUCTIONS (CONT).

Table 2-9. Troubleshooting (Cont)

| Malfunction | Test or Inspection | Corrective Action |
|--|---|--|
| STEERING SYSTEM (CONT) | | |
| 2. WANDERS OR PULLS TO ONE SIDE (CONT). |  <p style="text-align: right; margin-right: 50px;">TA184182</p> | <p>Step 8. Check front axle shafts for damage or wear by jacking up both wheels on one axle. Turn front wheels to one side and rotate one wheel by hand while listening for a rumbling or grinding sound in the axle. Then, repeat on other wheel.</p> <p style="padding-left: 40px;">If front axles are making noise, notify the supervisor.</p> |
| 3. SUDDEN INCREASE IN EFFORT TO TURN STEERING WHEEL. |  <p style="text-align: right; margin-right: 50px;">TA184186</p> | <p>Step 1. Check for low hydraulic oil level at indicator on reservoir.</p> <p style="padding-left: 40px;">Add oil as required (LO 9-2320-279-12). If oil is low, check reservoir for cracks or breaks. If reservoir is cracked or broken, replace reservoir (para 13-12).</p> |

Troubleshooting Malfunctions (Cont)
Table 2-9. Troubleshooting (Cont)

| Malfunction | Test or Inspection | Corrective Action |
|---|--------------------|-------------------|
| STEERING SYSTEM (CONT) | | |
| 3. SUDDEN INCREASE IN EFFORT TO TURN STEERING WHEEL (CONT). | | |
|  | | |
| <p>Step 2. Check steering gear hoses and fittings for leaks. Tighten loose connections or replace damaged hose (para 13-6) and add oil as required (LO 9-2320-279-12).</p> | | |
| <p>Step 3. Check steering linkage for free movement and noise. Lubricate steering linkage (LO 9-2320-279-12).</p> | | |
| <p>Step 4. Inspect both main and secondary (slave) steering gear for loose mounting or noises. Tighten loose mountings. Notify the supervisor if noises remain.</p> | | |
| <p>Step 5. Inspect drag links and tie rods for damage or loose ends. Tighten loose drag link or tie rod ends. Replace damaged drag links (para 13-4) or tie rods (para 13-5).</p> | | |
| <p>Step 6. Check axle shafts for defects by jacking up both wheels on axle. Turn wheels all the way to one side. Rotate one wheel at a time by hand. Listen for a rumbling or grinding sound while turning the wheel. Turn all wheels. If there is a rumbling or grinding sound, notify the supervisor.</p> | | |

Troubleshooting Malfunctions (Cont)

2-15. TROUBLESHOOTING INSTRUCTIONS (CONT).

Table 2-9. Troubleshooting (Cont)

| Malfunction | Test or Inspection | Corrective Action |
|--|--------------------|-------------------|
| <p>STEERING SYSTEM (CONT)</p> | | |
| <p>4. STEERING WHEEL DOES NOT TURN FULLY IN EITHER DIRECTION.</p> | | |
| <p>The diagram illustrates the steering mechanism. On the left, the steering wheel is connected to a column, which leads to a gear box. This gear box is linked to the main steering gear. From the main steering gear, a front drag link extends to the front axle. A secondary steering gear is connected to the rear axle via a rear drag link. Labels with arrows point to each of these components.</p> | | |
| <p>TA183993</p> | | |
| <p>Step 1. Check steering linkage and gears for proper lubrication. Lubricate steering linkage (LO 9-2320-279-12).</p> <p>Step 2. Check drag links and tie rods for looseness or damage. Tighten loose ends. Replace damaged drag links (para 13-4) or tie rods (para 13-5).</p> <p>Step 3. If steering is still impaired, notify the supervisor.</p> | | |
| <p>HYDRAULIC SYSTEM</p> | | |
| <p>1. WINCH, RETRIEVER SYSTEM, OR CRANE JERKS WHEN OPERATED.</p> | | |
| <p>The diagram shows a vertical hydraulic cylinder. At the top, there is a breather cap. A dipstick is inserted into the top of the cylinder. On the side of the cylinder, there is an oil level indicator window. Labels with arrows point to these three components.</p> | | |
| <p>TA184149</p> | | |

Troubleshooting Malfunctions (Cont)

Table 2-9. Troubleshooting (Cont)

| Malfunction | Test or Inspection | Corrective Action |
|--|--|--|
| HYDRAULIC SYSTEM (CONT) | | |
| 1. WINCH, RETRIEVER SYSTEM, OR CRANE JERKS WHEN OPERATED (CONT). | | |
| NOTE | | |
| <p>The hydraulic pump and reservoir supply power and oil to the power steering, winches, retriever, and crane systems. Refer to FO-3, Hydraulic Schematic. If there is a problem with hydraulics, make the checks for symptoms 1 and 2, then go to the Troubleshooting procedures for STEERING, WINCH, RETRIEVER, or CRANE systems.</p> | | |
| Step 1. | Check oil level in reservoir and check reservoir for cracks or breaks. | <p>Add oil as required (LO 9-2320-279-12). If reservoir is cracked or broken, replace reservoir (para 13-12) (M984El: para 13-16).</p> |
| Step 2. | Check for oil leaks (fig. 1-14). | <p>Tighten loose connections, replace damaged hoses. Add oil as required (LO 9-2320-279-12).</p> |
| <p>The diagram shows a top-down view of a hydraulic reservoir. On the left, a cylindrical sight level indicator is mounted on the reservoir's surface. A hose with a quick-disconnect fitting is connected to the reservoir. To the right, a cylindrical filter is mounted on the hose. Below the reservoir, a cylindrical strainer is shown. Labels with arrows point to each of these components: 'HYDRAULIC RESERVOIR', 'M984E1 SIMILAR', 'SIGHT LEVEL INDICATOR', 'FILTER', and 'STRAINERS'.</p> | | |
| Step 3. | Check hydraulic pump for leaks or damage at connections. | <p>Tighten loose connections at hydraulic pump, replace damaged hoses.</p> |
| Step 4. | Check if hydraulic oil is dirty, dark, or milky (contaminated). | <p>If contaminated, service reservoir (LO 9-2320-279-12). Replace oil return filter element (para 13-8) (M984El: para 13-13).</p> |
| Step 5. | If problem has not been solved, notify the supervisor. | |

Troubleshooting Malfunctions (Cont)

2-15. TROUBLESHOOTING INSTRUCTIONS (CONT).

Table 2-9. Troubleshooting (Cont)

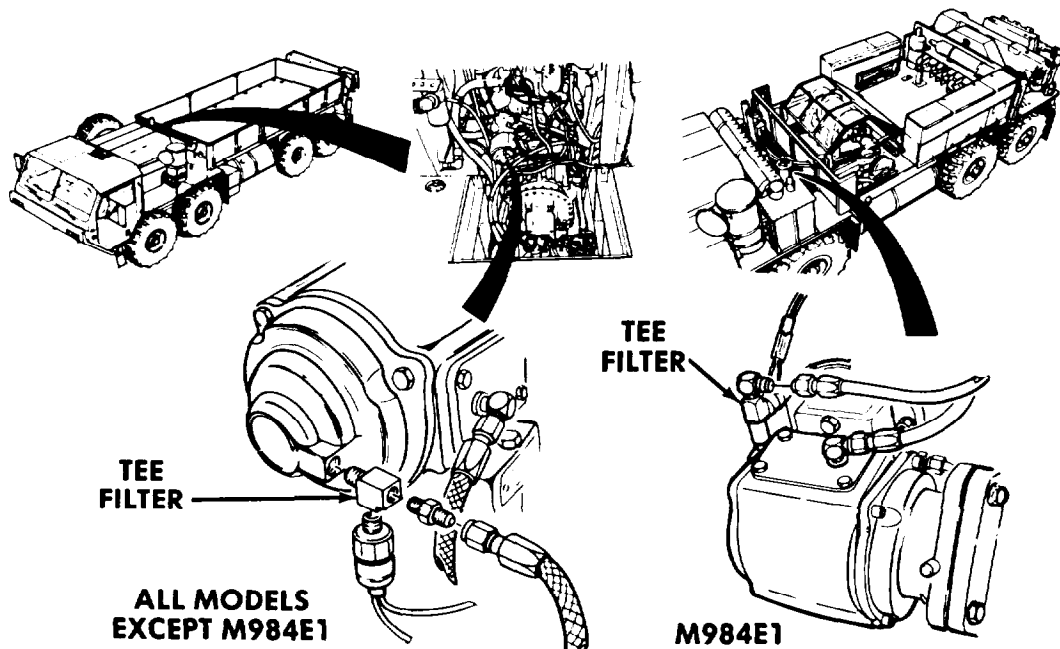
| Malfunction | Test or Inspection | Corrective Action |
|---|--|--|
| 2. ONE OR MORE HYDRAULIC CIRCUITS NOT WORKING. | | |
| Step 1. | Check to see if PTO switch has engaged PTO pump. You should hear a slight humming sound. | If the PTO pump has not engaged, refer to Electrical System Troubleshooting (page 2-116 thru 2-118). If PTO pump engages and one or more hydraulic circuits do not work, go on to Step 2. |
| Step 1.1 | Check selector valve for faulty operation, loose line connections, or damage. | Tighten loose connections. Replace if damaged (para 19-12). |
| Step 2. | M984El ONLY Check heavy-duty winch manifold valve for loose line connections or damage. | Tighten loose connections. Notify the supervisor if valve or lines are damaged. |
| Step 3. | Check for loose or damaged lines and connections (fig. 1-14) (M984El: fig. 1-14.1). | Tighten loose connections, replace damaged lines. |
| Step 4. | Check oil level in reservoir (LO 9-2320-279-12). | Add oil as necessary (LO 9-2320-279-12). |
| Step 5. | Check hydraulic pump for leaks. | Tighten loose line connections. Add oil as required (LO 9-2320-279-12). |
| Step 6. | Check relief valve for loose line connections or damage. | Tighten loose connections and replace damaged lines. |

Troubleshooting Malfunctions (Cont)

Table 2-9. Troubleshooting (Cont)

| Malfunction Test or Inspection | Corrective Action |
|-----------------------------------|-------------------|
|-----------------------------------|-------------------|

HYDRAULIC SYSTEM (CONT)

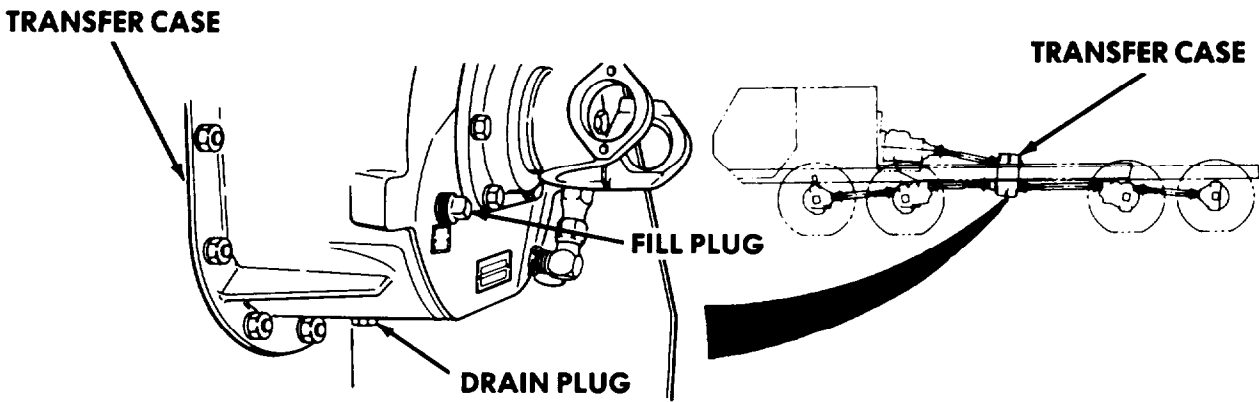


- Step 7. Remove hydraulic hose from tee connection, place hose end in suitable container. Start engine, engage PTO switch.
 - If hydraulic oil discharges into container, go to step 8.
 - If no oil discharges, go to step 9.
- Step 8. Remove tee and check for clogged filter.
 - Clean if required. If PTO still does not work, replace PTO (para 17-28) (M984E1: para 17-28.1).
- Step 9. Remove transmission hydraulic line from PTO solenoid. Place hose in suitable container. Start engine.
 - If oil discharges, replace solenoid (para 17-30).
 - If oil does not discharge, notify the supervisor.

Troubleshooting Malfunctions (Cont)

2-15. TROUBLESHOOTING INSTRUCTIONS (CONT).

Table 2-9. Troubleshooting (Cont)

| Malfunction | Test or Inspection | Corrective Action |
|---|--|-------------------|
| TRANSFER CASE | | |
| . NOISY TRANSFER CASE. | | |
|  | | |
| Step 1. | Check oil level (LO 9-2320-279-12) Add oil as required (LO 9-2320-279-12). | |
| Step 2. | Check for dirty, dark, or milky oil (contamination). Change oil (LO 9-2320-279-12). | |

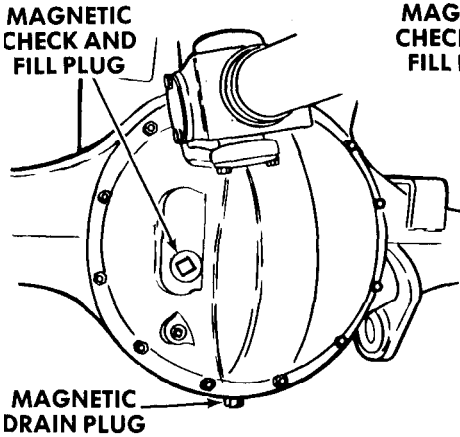
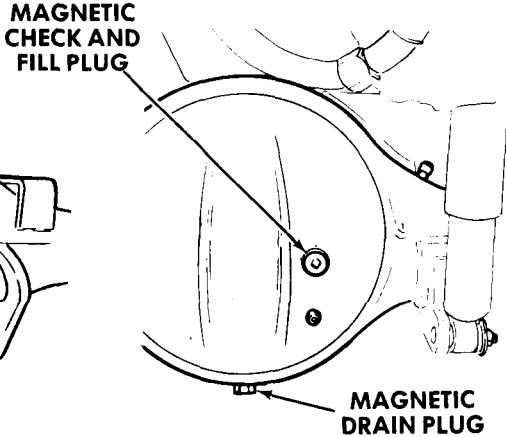
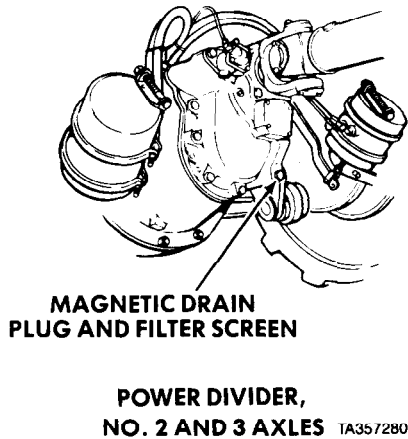
Troubleshooting Malfunctions (Cont)
 Table 2-9. Troubleshooting (Cont)

| Malfunction | Test or Inspection | Corrective Action |
|---|--------------------|-------------------|
| TRANSFER CASE (CONT) | | |
| 1. NOISY TRANSFER CASE (CONT). | | |
| Step 3. Check hoses and connections at front and rear of case. | | |
| Tighten if loose, replace if damaged. | | |
| Step 4. If problem has not been solved, notify the supervisor. | | |
| 2. TRANSFER CASE DOES NOT SHIFT INTO HIGH OR LOW, OR SLIPS OUT OF GEAR. | | |
| Step 1. Check shift linkage for missing or damaged parts. | | |
| If cable control is damaged, or other parts are missing or damaged, replace (para 9-4). | | |
| Step 2. Check shift linkage adjustment (para 9-5). | | |
| Adjust as required (para 9-5). | | |
| Step 3. Notify the supervisor if problem has not been solved. | | |
| PROPELLER SHAFTS AND UNIVERSAL JOINTS | | |
| 1. NOISY OR VIBRATING PROPELLER SHAFT OR U-JOINTS. | | |
| | | |
| TA184140 | | |
| Step 1. Check for play in U-joints. | | |
| If there is any movement, replace U-joints (para 9-10). | | |
| Step 2. Inspect propeller shafts and U-joints for damage. | | |
| Replace damaged parts (paras 9-9 and 9-10). | | |
| Step 3. Check for excessive wear at propeller shaft slip joint. Inspect splines for wear. | | |
| If excessive wear is found, replace propeller shaft (para 9-9). | | |

Troubleshooting Malfunctions (Cont)

2-15. TROUBLESHOOTING INSTRUCTIONS (CONT).

Table 2-9. Troubleshooting (Cont)

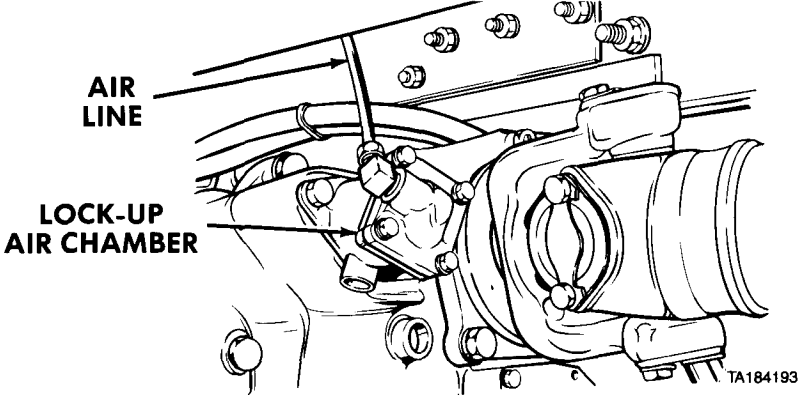
| Malfunction | Test or Inspection | Corrective Action |
|--|---|--|
| FRONT AND REAR AXLE TANDEMS | | |
| 1. NOISY DRIVE AXLE. | | |
| Step 1. Check lubricant level in differentials (LO 9-2320-279-12). | | |
| Add lubricant as required (LO 9-2320-279-12). | | |
|  |  |  |
| NO. 2 AND 3 DIFFERENTIALS | NO. 1 AND 4 AXLE DIFFERENTIALS | POWER DIVIDER, NO. 2 AND 3 AXLES TA357280 |
| Step 2. Drain axle differentials (LO 9-2320-279-12). Check bottom magnetic drain plug for metal particles when draining. | | |
| If metal particles are small, like metal filings, replace lubricant (LO 9-2320-279-12). | | |
| If metal particles are larger than filings, notify the supervisor. | | |
| Step 3. Check drive pinion yoke for looseness. | | |
| If looseness is found, notify the supervisor. | | |
| Step 4. Check wheel bearings. Jack wheel off ground (TM 9-2320-279-10). Put pinch bar under tire to raise tire and check for play in wheel bearings. Turn wheel and check for roughness in wheel bearings. | | |
| If roughness or looseness is detected, adjust or replace bearings (para 12-2 or 12-3). | | |
| Step 5. Test drive vehicle on and off roads. Listen for grinding or rumbling noise when driving and turning. | | |
| If there is noise when turning, notify the supervisor. | | |

Troubleshooting Malfunctions (Cont)
Table 2-9. Troubleshooting (Cont)

| Malfunction | Test or Inspection | Corrective Action |
|-------------|--------------------|-------------------|
|-------------|--------------------|-------------------|

FRONT AND REAR AXLE TANDEMS (CONT)

2. DIFFERENTIAL LOCK-UP DOES NOT ENGAGE OR DISENGAGE.



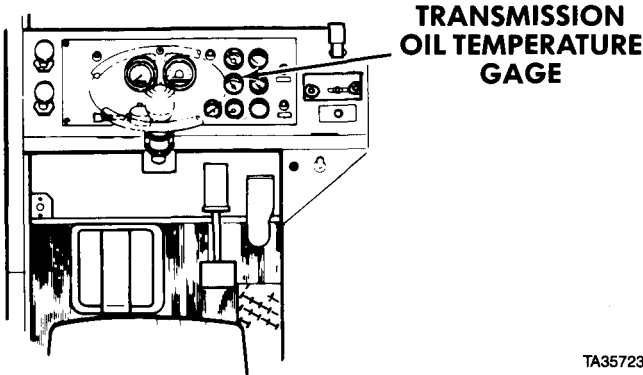
Step 1. Check for broken or kinked air line tubing or loose connections at No. 2 and No. 3 axles.
 Replace broken or kinked air line tubing.
 Tighten loose connection.

Step 2. Go to AIR SYSTEM Troubleshooting, MALFUNCTION 16, AXLES WILL NOT LOCK UP.

Step 3. If problem is not solved, notify the supervisor.

TRANSMISSION

1. TRANSMISSION OIL TEMPERATURE GAGE CONTINUOUSLY READS OVER 250 °F.

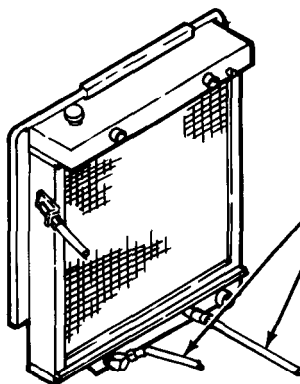
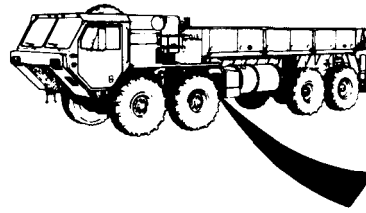
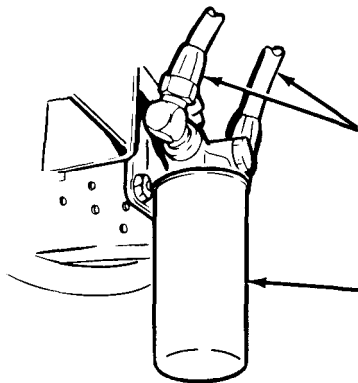


Step 1. Check transmission fluid level (LO 9-2320-279-12).
 Add or drain transmission fluid as required (LO 9-2320-279-12).

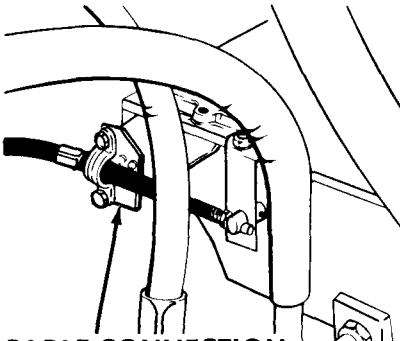
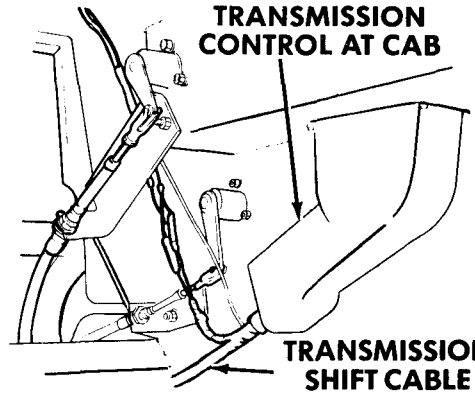
Troubleshooting Malfunctions (Cont)

2-15. TROUBLESHOOTING INSTRUCTIONS (CONT).

Table 2-9. Troubleshooting (Cont)

| Malfunction | Test or Inspection | Corrective Action |
|--|---|---|
| TRANSMISSION (CONT) | | |
| 1. TRANSMISSION OIL TEMPERATURE GAGE CONTINUOUSLY READS OVER 250 °F (CONT). | <p>NOTE: TRANSMISSION OIL COOLER IS PART OF RADIATOR</p> |  <p>OIL COOLER HOSES</p> <p>TA357237</p> |
| Step 2. Check for clogged or damaged transmission oil cooler. If clogged or damaged, replace radiator (para 6-3). |  |  <p>LINE CONNECTORS</p> <p>EXTERNAL TRANSMISSION OIL FILTER</p> <p>TA188267</p> |
| Step 3. Check for plugged or clogged transmission oil filter. Replace transmission oil filter (para 8-7). | | |
| Step 4. Check for leaks at oil lines on transmission. Tighten connections and add oil as required (LO 9-2320-279-12). | | |
| Step 5. If problem has not been solved, notify the supervisor. | | |

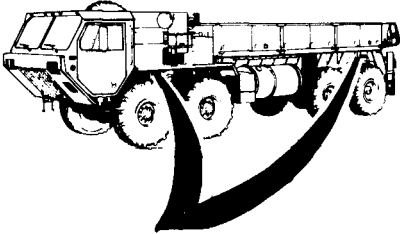
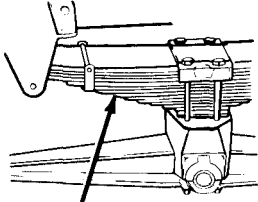
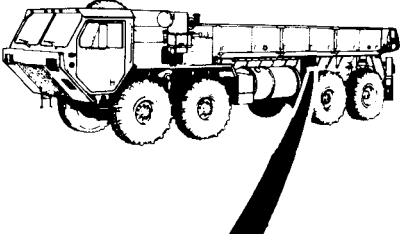
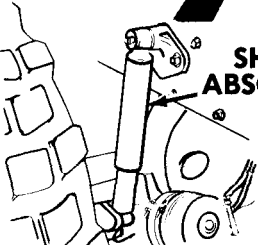
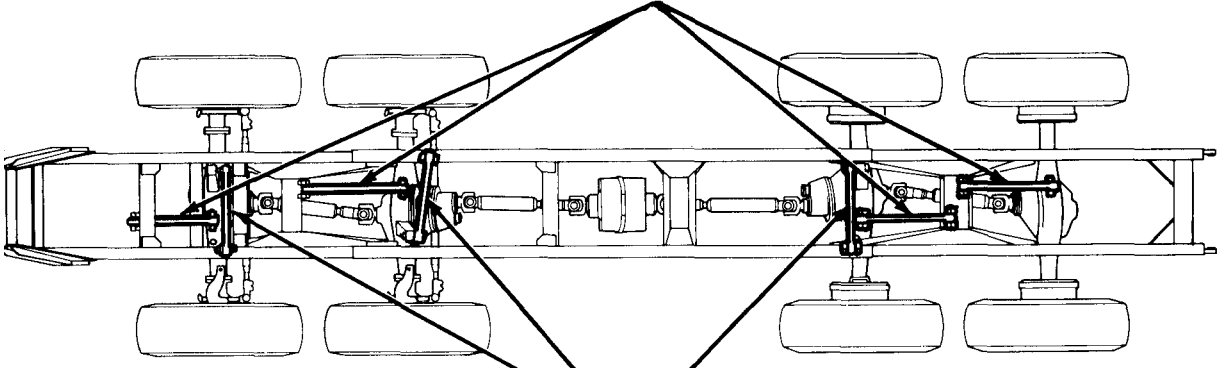
Troubleshooting Malfunctions (Cont)
 Table 2-9. Troubleshooting (Cont)

| Malfunction | Test or Inspection | Corrective Action |
|---|--------------------|-------------------|
| TRANSMISSION (CONT) | | |
| 2. TRANSMISSION NOISY. | | |
| Step 1. Check fluid level in transmission (LO 9-2320-279-12). | | |
| Add fluid as required (LO 9-2320-279-12). | | |
| Step 2. If transmission is still noisy, notify the supervisor. | | |
| 3. WILL NOT SHIFT INTO GEAR, SLIPS OUT OF GEAR, OR OPERATES ABNORMALLY. | | |
| <div style="display: flex; justify-content: space-around; align-items: center;"> <div style="text-align: center;">  <p>CABLE CONNECTION AT TRANSMISSION</p> </div> <div style="text-align: center;">  <p>TRANSMISSION CONTROL AT CAB</p> <p>TRANSMISSION SHIFT CABLE</p> <p><small>TA184163</small></p> </div> </div> | | |
| Step 1. Check control, control cable, and linkage from cab back to transmission for damage or looseness. | | |
| Adjust as required (para 8-2) or replace cable (para 8-2) or control (para 8-3). | | |
| Step 2. Check fluid in transmission (LO 9-2320-279-12). | | |
| Add or drain fluid (LO 9-2320-279-12). | | |
| Step 3. If problem has not been solved, notify the supervisor. | | |

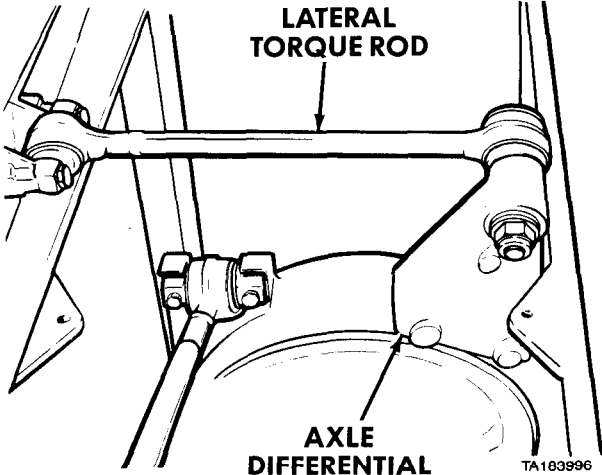
Troubleshooting Malfunctions (Cont)

2-15. TROUBLESHOOTING INSTRUCTIONS (CONT).

Table 2-9. Troubleshooting (Cont)

| Malfunction | Test or Inspection | Corrective Action |
|---|--------------------|-------------------|
| <p>SUSPENSION (SHOCK ABSORBERS, SPRINGS, AND TORQUE RODS)</p> | | |
| <p>1. VEHICLE WANDERS OR SHIMMIES.</p> | | |
| <div style="display: flex; justify-content: space-around; align-items: center;"> <div style="text-align: center;">   <p>LEAF SPRING ASSEMBLY</p> </div> <div style="text-align: center;">   <p>SHOCK ABSORBERS</p> </div> </div> <p style="text-align: right; margin-right: 50px;">TA184181</p> | | |
| <p>Step 1. Check shock absorbers and leaf spring assemblies for loose mounting and broken parts. Tighten loose mountings or replace broken shock absorbers (para 15-2). If leaf spring assemblies have broken parts, notify the supervisor.</p> | | |
| <div style="text-align: center;"> <p>TORQUE RODS</p>  <p>FRONT REAR</p> <p style="text-align: center;">LATERAL TORQUE RODS</p> </div> <p style="text-align: right; margin-right: 50px;">TA183982</p> | | |

Troubleshooting Malfunctions (Cont)
 Table 2-9. Troubleshooting (Cont)

| Malfunction | Test or Inspection | Corrective Action |
|---|---|---|
| SUSPENSION (SHOCK ABSORBERS, SPRINGS, AND TORQUE RODS) | | |
| 1. VEHICLE WANDERS OR SHIMMIES (CONT). | Step 2. Check all seven torque rods mounted on top of axles for damage and loose mounting screws. | Replace damaged torque rods and tighten loose mounting screws (para 15-5). Notify the supervisor if lateral torque rods are damaged. |
| 2. VEHICLE LEANS TO ONE SIDE, OR REAR SAGS. | Step 1. Check suspension for damage. | If springs are damaged, notify the supervisor. |
| 3. REAR AXLE TANDEM OUT OF LINE OR NOT TRACKING PROPERLY. |  | |
| | Step 1. Inspect lateral torque rod for damage. | If damage is found, notify the supervisor. |

Troubleshooting Malfunctions (Cont)

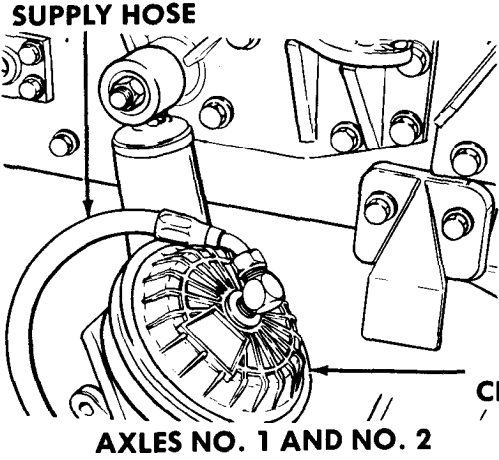
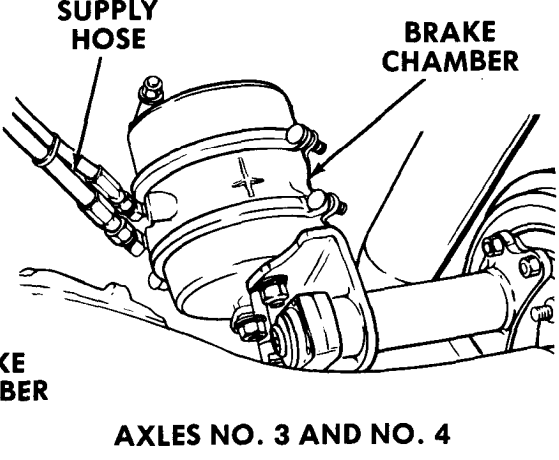
2-15. TROUBLESHOOTING INSTRUCTIONS (CONT).

Table 2-9. Troubleshooting (Cont)

| Malfunction Test or Inspection | Corrective Action |
|--|--|
| <p>DUAL AIR BRAKE SYSTEM</p> | |
| <p>1. BRAKES WILL NOT RESPOND PROPERLY.</p> | <p>Step 1. Check air pressure gage for 100 to 120 psi (690 to 827 kPa). If air pressure gage does not read 100 to 120 psi (690 to 827 kPa), go to AIR SYSTEM troubleshooting, MALFUNCTION 1, AIR PRESSURE BUILDUP SLOW.</p> <p>Step 2. Check air brake lines and brake components for leakage or damage. Replace or repair leaking or damaged air lines or brake components (go to Alphabetical Index to find component replacement procedures).</p> |
| <p>The diagram shows a cross-section of an air brake chamber and its associated slack adjuster. The chamber is on the right, with a rod extending from its center. This rod is connected to a slack adjuster on the left. The slack adjuster has a circular head with a hole in the center. An adjust screw is located on the side of the slack adjuster. The diagram illustrates the 'BRAKE OFF POSITION' where the chamber rod is retracted and the 'BRAKE APPLIED POSITION' where the chamber rod has extended, pushing against the slack adjuster. A dimension line indicates the 'LENGTH OF AIR CHAMBER STROKE'. The 'ADJUST SCREW' is used to adjust the slack between the chamber rod and the slack adjuster.</p> | |
| <p>Step 3. Check slack adjusters for adjustment or damage.</p> | <p>Adjust brakes (para 11-7) or replace damaged slack adjusters (para 11-5 or 11-6).</p> |
| <p>Step 4. Check operation of air brake chambers.</p> | <p>If brake chamber rod does not extend when brakes are applied, check internal brake. Check internal brake parts for oil contamination or damage. Replace or repair brake parts as required (para 10-3, 11-2, 11-3, 11-4).</p> |

TA184166

Troubleshooting Malfunctions (Cont)
 Table 2-9. Troubleshooting (Cont)

| Malfunction | Test or Inspection | Corrective Action |
|--|---|--|
| DUAL AIR BRAKE SYSTEM (CONT) | | |
| 1. BRAKES WILL NOT RESPOND PROPERLY (CONT). |  |  |
| <p>Step 5. Loosen supply hose at brake chamber. Apply service brake and listen for air escaping from supply hose.</p> <p style="padding-left: 40px;">If air is heard escaping, replace defective brake chambers (para 11-8 or 11-9).</p> | | |

TA357238

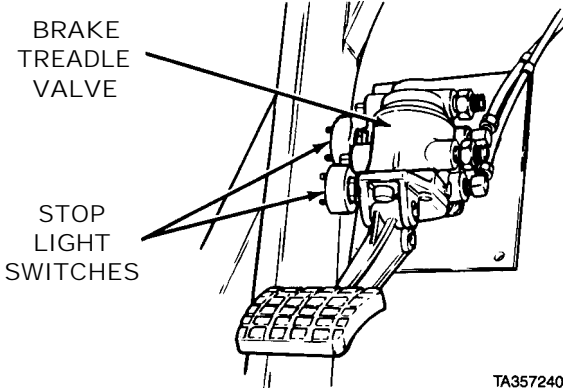
Troubleshooting Malfunctions (Cont)

2-15. TROUBLESHOOTING INSTRUCTIONS (CONT).

Table 2-9. Troubleshooting (Cont)

| Malfunction | Test or Inspection | Corrective Action |
|---|--------------------|-------------------|
| <p>DUAL AIR BRAKE SYSTEM (CONT)</p> | | |
| <p>1. BRAKES WILL NOT RESPOND PROPERLY (CONT).</p> | | |
| <p style="text-align: right; font-size: small;">TA357239</p> | | |
| <p>Step 6. Check air supply to brake relay valve. Drain air system. Loosen supply line at brake relay valve. Start engine and build air pressure, listen for air escaping from supply hose.</p> | | |
| <p style="padding-left: 40px;">If no air is heard escaping from supply hose, inspect supply hose for kinks or restrictions. Repair or replace air lines as required (para 11-35).</p> | | |
| <p>Step 7. Check for correct control air supply. Loosen control line at brake relay valve. Apply service brake and listen for air escaping from control air supply hose.</p> | | |
| <p style="padding-left: 40px;">If air is heard escaping, replace defective brake relay valve (para 11-12).</p> | | |

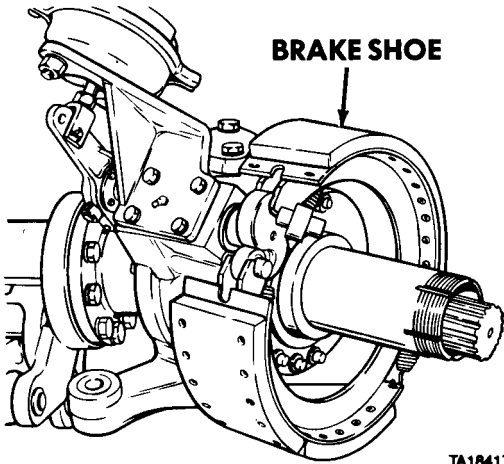
Troubleshooting Malfunctions (Cont)
Table 2-9. Troubleshooting (Cont)

| Malfunction | Test or Inspection | Corrective Action |
|---|--------------------|-------------------|
| DUAL AIR BRAKE SYSTEM (CONT) | | |
| 1. BRAKES WILL NOT RESPOND PROPERLY (CONT) . | | |
|  <p>The diagram shows a mechanical assembly with two main components labeled: 'BRAKE TREADLE VALVE' and 'STOP LIGHT SWITCHES'. The brake treadle valve is a cylindrical component with a handle. The stop light switches are located below it. A treadle pedal is shown at the bottom, connected to the valve. The diagram is labeled 'TA357240'.</p> | | |
| <p>Step 8. Check for defective brake treadle valve. Remove both stoplight switches from brake treadle valve. Apply service brakes and listen for air escaping from brake treadle valve stoplight switch holes.</p> | | |
| <p style="padding-left: 40px;">If air is not heard escaping from both holes, replace defective brake treadle valve (para 11-10).</p> | | |
| <p style="padding-left: 40px;">If air is heard escaping, inspect double check valve in line No. 489 (all models) or in line No. 489A (M984E 1 only) for damage. Replace damaged double check valve (para 11-14 or 11-15).</p> | | |

Troubleshooting Malfunctions (Cont)

2-15. TROUBLESHOOTING INSTRUCTIONS (CONT).

Table 2-9. Troubleshooting (Cont)

| Malfunction | Test or Inspection | Corrective Action |
|--|--------------------|-------------------|
| DUAL AIR BRAKE SYSTEM (CONT) | | |
| 2. UNEVEN BRAKING. | | |
| Step 1. Check brake adjustment. | | |
| Adjust brakes (para 11-7) or replace slack adjusters (para 11-5 or 11-6). | | |
|  | | |
| Step 2. Check for worn or glazed linings or scored drums. | | |
| Replace shoes if worn or glazed (para 11-3 or 11-4). | | |
| Replace drum if scored (para 12-2 or 12-4). | | |
| Step 3. Check air lines for leaks or damage. | | |
| Repair air lines as required. | | |

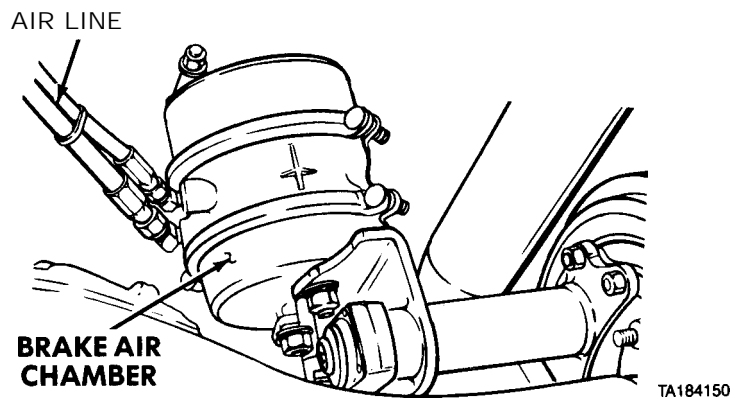
Troubleshooting Malfunctions (Cent)
Table 2-9. Troubleshooting (Cont)

Malfunction

Test or Inspection

Corrective Action

DUAL AIR BRAKE SYSTEM (CONT)

2. UNEVEN BRAKING (CONT).

Step 4. Check operation of brake chamber (go to MALFUNCTION 1, BRAKES WILL NOT RESPOND PROPERLY, Step 4).

Replace if damaged (para 11-8 or 11-9).

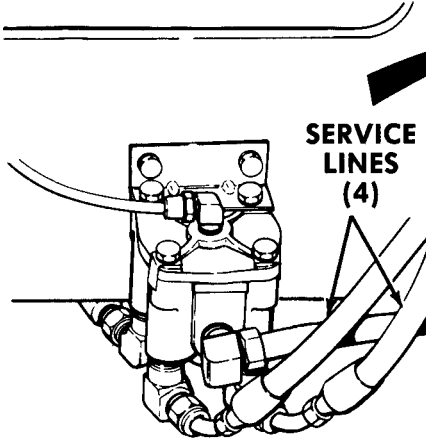
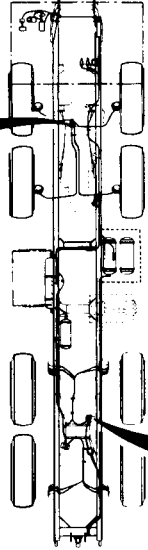
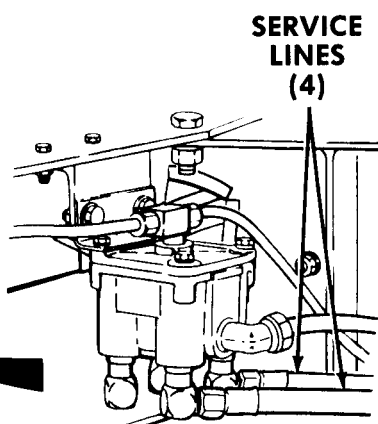
Step 5. Check brake treadle valve for leaks or damage (go to MALFUNCTION 1, Step 8).

Tighten loose connections, replace if leaking or damaged (para 11-10).

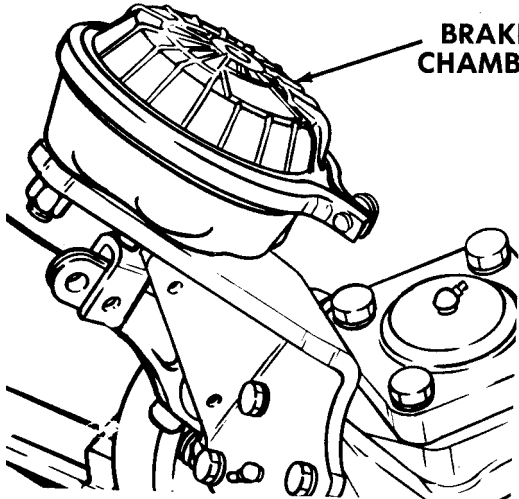
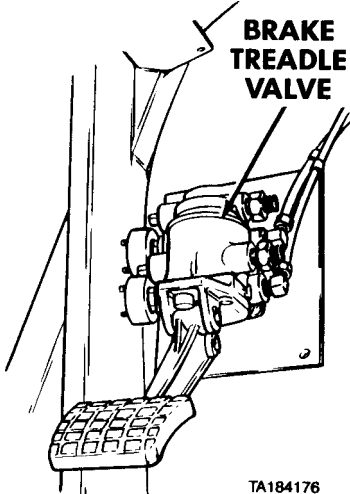
Troubleshooting Malfunctions (Cont)

12-15. TROUBLESHOOTING INSTRUCTIONS (CONT).

Table 2-9. Troubleshooting (Cont)

| Malfunction Test or Inspection | Corrective Action |
|--|-------------------|
| DUAL AIR BRAKE SYSTEM (CONT) | |
| 3. SERVICE BRAKES FAIL TO RELEASE OR RELEASE SLOWLY. | |
| <p>Step 1. Check brake adjustment.</p> <p style="padding-left: 40px;">If brakes are out of adjustment, adjust brakes (para 11-7).</p> | |
| <div style="display: flex; justify-content: space-around; align-items: center;">    </div> <p style="text-align: right; font-size: small;">TA357241</p> | |
| <p>Step 2. Check for defective service brake relay valve. Start engine and build up air pressure. Apply and release service brake. Carefully remove air line from service port of service brake relay valve.</p> <p style="padding-left: 40px;">If air escapes, replace service brake relay valve (para 11-12).</p> | |
| <p>Step 3. Remove brake drum. Check S-cams and other moving brake parts for binding or damage.</p> <p style="padding-left: 40px;">If binding or damage is found, lubricate or replace damaged brake parts (para 11-3, 11-4, 11-5, or 11-6).</p> | |
| 4. BRAKES GRAB WHEN APPLIED. | |
| <p>Step 1. Check brake adjustment (para 11-7).</p> <p style="padding-left: 40px;">Adjust brakes (para 11-7).</p> | |
| <p>Step 2. Remove brake hub and drum assembly (para 12-2). Check for worn, glazed, or contaminated brake linings.</p> <p style="padding-left: 40px;">Replace worn, glazed, or contaminated brake shoes (para 11-3 or 11-4).</p> | |

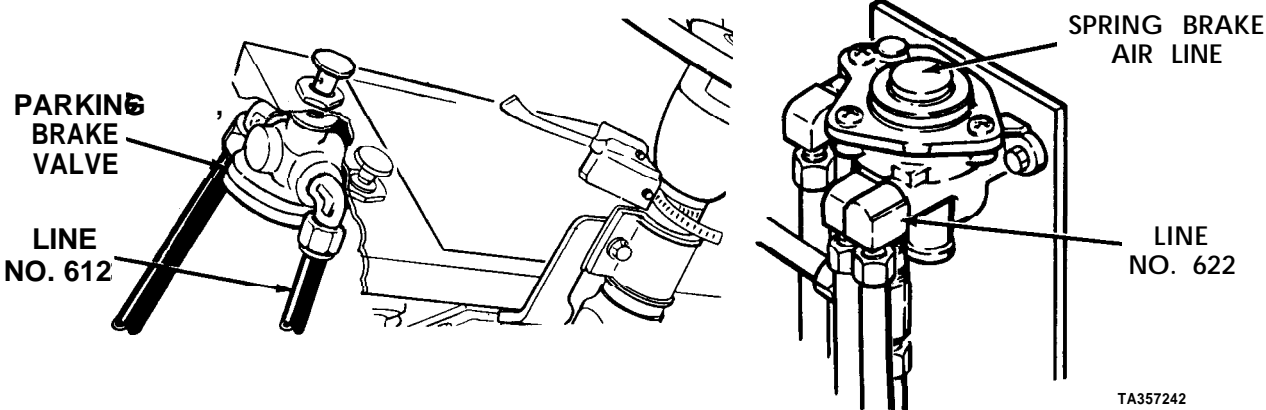
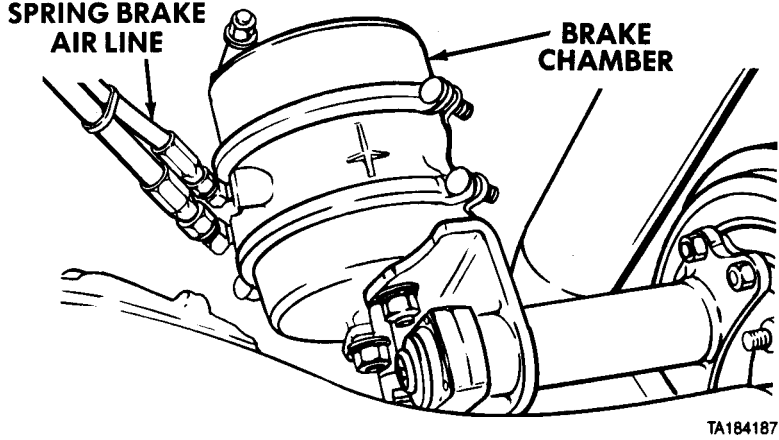
Troubleshooting Malfunctions (Cont)
 Table 2-9. Troubleshooting **(Cont)**

| Malfunction | Test or Inspection | Corrective Action |
|--|--|---|
| DUAL AIR BRAKE SYSTEM (CONT) | | |
| 5. PRESSURE DROPS OVER 25 PSI (172 kPa) AT GAGE WHEN BRAKES ARE APPLIED. | | |
|  |  | |
| | | TA184176 |
| | Step 1. Check brake treadle valve for leaks. | Replace leaking treadle valve (para 11-10). |
| | Step 2. Check for air leak at brake chambers. | If air is leaking from brake chamber, replace (para 11-8 or 11-9). |
| | Step 3. Check for leaks at relay valve. | If air is leaking from relay valve, replace relay valve (para 11-12). |
| | Step 4. Check air lines for leaks. | Repair air lines (para 11-35). |
| 5. SPRING BRAKES WILL NOT APPLY. | | |
| | Step 1. Check brake adjustment. | Adjust brakes (para 11-7). |
| | Step 2. Check for kinked or damaged air lines from parking brake valve in cab to spring brake. | Repair kinked or damaged air lines or connectors (para 11-35). |

Troubleshooting Malfunctions (Cent)

2-15. TROUBLESHOOTING INSTRUCTIONS (CONT).

Table 2-9. Troubleshooting (Cent)

| Malfunction Test or Inspection | Corrective Action |
|---|---|
| DUAL AIR BRAKE SYSTEM (CONT) | |
| 5. SPRING BRAKES WILL NOT APPLY (CONT). | |
|  | |
| <p>Step 3. Apply spring brakes. Disconnect line No. 612 at parking brake valve. Listen for air escaping.</p> | <p>If air escapes, replace defective parking brake valve (para 11-20).</p> |
| <p>Step 4. Apply spring brakes. Disconnect line No. 622 at spring brake control valve. Listen for air escaping.</p> | <p>If air escapes, replace defective spring brake control valve (para 11-17).</p> |
|  | |
| <p>Step 5. Apply spring brakes. Loosen spring brake air line on brake chamber.</p> | <p>If air escapes out of air line, replace defective spring brake relay valve (para 11-13).</p> |
| <p>If no air escapes, check for binding slack adjusters or damaged brake chamber, repair or replace components as required.</p> | |

Troubleshooting Malfunctions (Cont)

Table 2-9. Troubleshooting (Cont)

| Malfunction | Test or Inspection | Corrective Action |
|-------------|--------------------|-------------------|
|-------------|--------------------|-------------------|

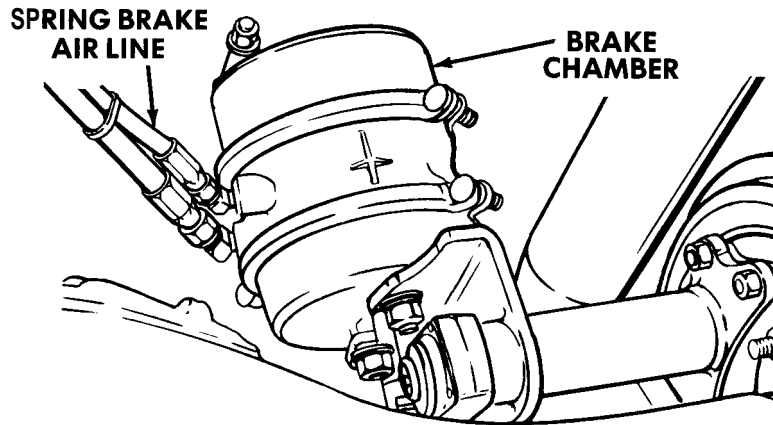
DUAL AIR BRAKE SYSTEM (CONT)

7. SPRING BRAKES WILL NOT RELEASE.

Step 1. Check for binding slack adjuster. Lubricate slack adjuster (LO 9-2320-279-12).

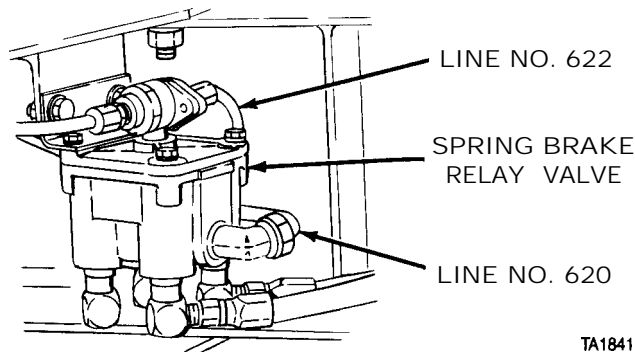
Step 2. Check air lines and spring brake components for leaks or damage.

If lines or spring brake components are leaking or damaged, repair lines or replace components (go to Alphabetical Index to find component replacement procedures).



Step 3. Release parking brakes. Loosen spring brake air line on brake chamber.

If air comes out of hose, replace brake chamber (para 11-8).



Step 4. Release spring brakes. Loosen line No. 620 at spring brake relay valve.

If air does not come out of line No. 620, replace No. 1 air manifold (para 11-25).

Step 5. Loosen line No. 622 at spring brake relay valve.

If air comes out of line No. 622, replace spring brake relay valve (para 11-17).

Troubleshooting Malfunctions (Cent)

2-15. TROUBLESHOOTING INSTRUCTIONS (CONT).

Table 2-9. Troubleshooting (Cont)

| Malfunction | Test or Inspection | Corrective Action |
|--|--------------------|-------------------|
| DUAL AIR BRAKE SYSTEM (CONT) | | |
| 7. SPRING BRAKES WILL NOT RELEASE (CONT). | | |
| | | |
| <p>Step 6. Release parking brakes. Loosen line No. 612 at parking brake valve. If no air comes out of line No. 612, replace parking brake valve (para 11-20). If air comes out of line No. 612, replace spring brake control valve (para 11-17).</p> | | |
| 8.- BRAKES OVERHEAT. | | |
| <p>Step 1. Check brakes for proper adjustment. Adjust brakes (para 11-7).</p> <p>Step 2. Check that brakes are releasing (go to MALFUNCTION 3, Steps 2 and 3). Replace damaged components (para 11-3 or 11-4).</p> | | |

Troubleshooting Malfunctions (Cont)

Table 2-9. Troubleshooting (Cont)

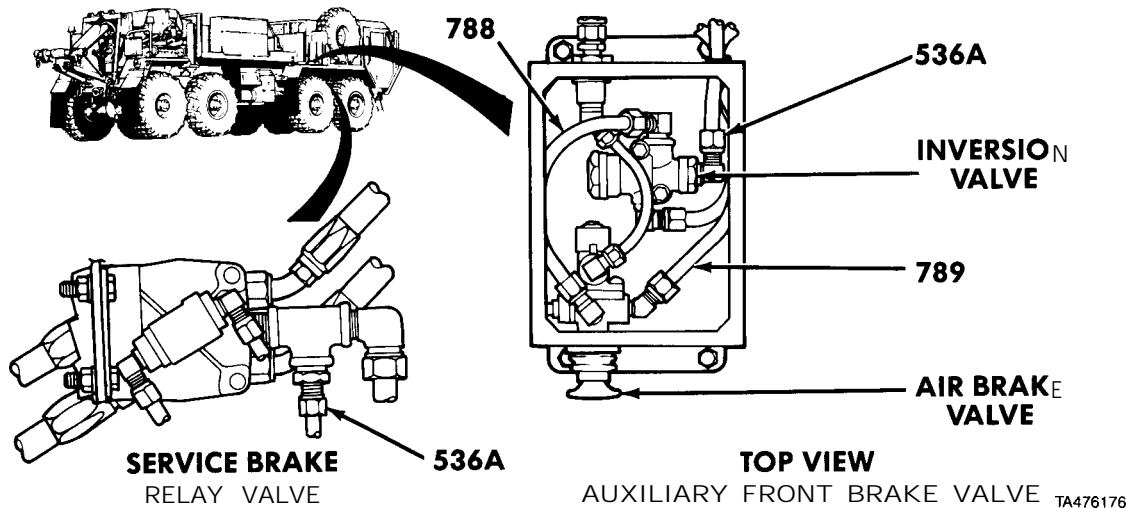
Malfunction

Test or Inspection

Corrective Action

DUAL AIR BRAKE SYSTEM (CONT)

9. FRONT AXLE PARKING BRAKES WILL NOT APPLY (M984E1).



Step 1. Remove cover from auxiliary front brake valve (para 11-21.2). Check air line 536A from auxiliary front brake valve to service brake relay valve for breaks, kinks, or leaks.

Tighten or replace damaged or leaking line.

Step 2. Apply front axle brakes (TM 9-2320-279-10). Loosen line 788 at inversion valve.

If no air comes out of inversion valve, replace inversion valve (para 11-2 1.2).

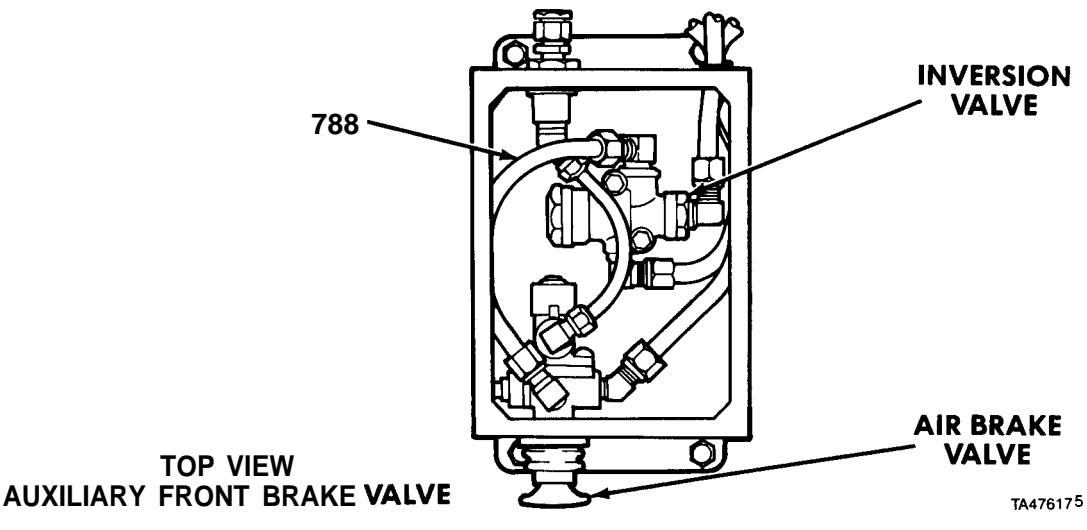
Step 3. Apply front axle brakes (TM 9-2320-279-10). Loosen line 789 at air brake valve.

If no air comes out of air brake valve, replace air brake valve (para 11-2 1.2).

Troubleshooting Malfunctions (Cont)

12-15. TROUBLESHOOTING INSTRUCTIONS (CONT).

Table 2-9. Troubleshooting (Cont)

| Malfunction Test or Inspection | Corrective Action |
|---|-------------------|
| DUAL AIR BRAKE SYSTEM (CONT) | |
| 10. FRONT AXLE PARKING BRAKES WILL NOT RELEASE (M984E1). | |
|  | |
| <p>Step 1. Remove cover from auxiliary front brake valve (para 11-2 1.2). Release front axle parking brakes (TM 9-2320-279-10). Loosen line 789 at air brake valve. If air comes out of air brake valve, replace air brake valve (para 11-21.2).</p> <p>Step 2. Release spring brakes (TM 9-2320-279-10). Loosen line 788 at inversion valve. If air comes out of inversion valve, replace inversion valve (para 11-21 .2).</p> | |
| WHEELS AND TIRES | |
| 1. TIRE UNEVENLY WORN. | |
| <p>Step 1. Check wheel bearings for looseness. Adjust wheel bearings (para 12-2 or 12-3), replace if damaged (para 12-2 or 12-3). Lubricate wheel bearings as required (LO 9-2320-279-12).</p> <p>Step 2. Check for damaged tie rods or drag links. Replace damaged tie rods (para 13-5). Replace damaged drag links (para 13-4).</p> <p>Step 3. Notify the supervisor for wheel alinement.</p> | |

Troubleshooting Malfunctions (Cont)
 Table 2-9. **Troubleshooting (Cont)**

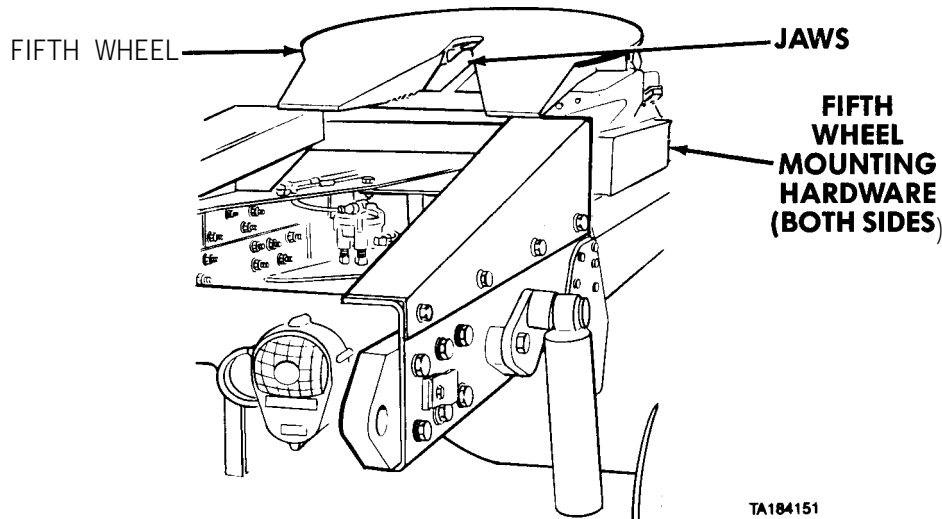
Malfunction

Test or Inspection

Corrective Action

FIFTH WHEEL

1. EXCESSIVE MOVEMENT OF TRAILER KINGPIN IN FIFTH WHEEL.



TA184151

- Step 1. Check for loose, missing, or broken mounting hardware.
 Tighten or replace loose hardware (para 14-19).
- Step 2. Check for loose or broken kingpin jaws.
 Replace fifth wheel assembly (para 14-19).

SELF-RECOVERY WINCH

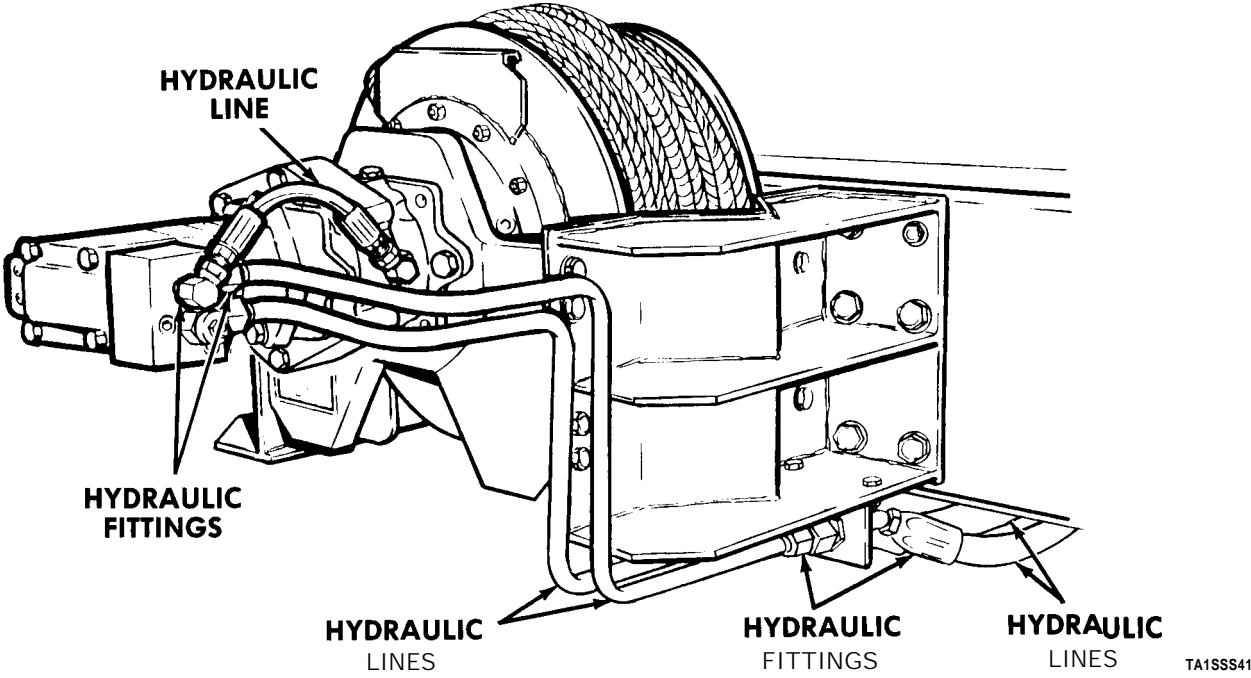
1. WINCH OPERATION IS JERKY, SLOW, OR DOES NOT WORK.

- Step 1. Check position of selector valve on fender.
 Put valve in proper position (TM 9-2320-279-10).
- Step 2. Go to HYDRAULIC SYSTEM Troubleshooting and make the checks shown in MALFUNCTIONS 1 and 2. Return to this section if problem has not been solved.

Troubleshooting Malfunctions (Cent)

12-15. TROUBLESHOOTING INSTRUCTIONS (CONT).

Table 2-9. Troubleshooting (Cent)

| Malfunction |
|--|
| Test or Inspection |
| Corrective Action |
| <p>SELF-RECOVERY WINCH (CONT)</p> <p>1. WINCH OPERATION IS JERKY, SLOW, OR DOES NOT WORK (CONT).</p>  |
| <p>Step 3. Check all hydraulic lines and fittings at winch hydraulic motor for looseness or damage. Tighten loose lines. Add oil as required (LO 9-2320-279-12). Replace if damaged.</p> <p>Step 4. Check PTO-driven hydraulic pump and hydraulic lines for leaks. Tighten loose connections. Replace damaged lines. Add oil as required (LO 9-2320-279-12).</p> <p>Step 5. Check hydraulic lines and fittings at control valve for looseness or damage. Tighten loose fittings. Replace damaged lines. Add oil as required (LO 9-2320-279-12).</p> <p>Step 6. Check linkage between self-recovery winch control valve and winch control lever for damage. If linkage is damaged, replace damaged linkage (para 19-3).</p> |

Troubleshooting Malfunctions (Cent)

Table 2-9. Troubleshooting (Cent)

| Malfunction | Test or Inspection | Corrective Action |
|-------------|--------------------|-------------------|
|-------------|--------------------|-------------------|

SELF-RECOVERY WINCH (CONT)

1. WINCH OPERATION IS JERKY, SLOW, OR DOES NOT WORK (CONT).

Step 7. Check for damaged self-recovery winch control valve. Remove both hydraulic hoses at mounting bracket. Place hose ends in a suitable container. Start engine and engage P'ID. Operate self-recovery winch IN and OUT.

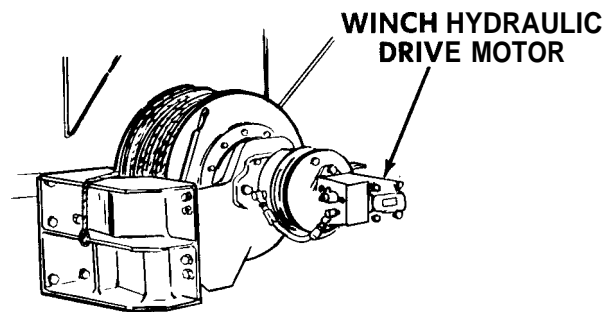
If hydraulic oil does not discharge into container when operated IN and OUT, replace defective self-recovery winch control valve (para 19-7).

Step 8. Check pump for overheating. Pump is normally hot during heavy use. If pump is too hot to touch, notify the supervisor.

Step 9. Check hydraulic motor for unusual sounds and oil leaks.

If there are leaks or unusual sounds, or if problem has not been solved, notify the supervisor.

2. EXCESSIVE NOISE FROM WINCH.



TA184153

Step 1. Inspect hydraulic motor at winch for loose mounting, excessive vibration, and leaks.

Tighten loose hardware. If hydraulic oil is low, fill reservoir (LO 9-2320-279-12).

Step 2. If problem remains, notify the supervisor.

Troubleshooting Malfunctions (Cent)

12-15. TROUBLESHOOTING INSTRUCTIONS (CONT).

Table 2-9. Troubleshooting (Cent)

| Malfunction | Test or Inspection | Corrective Action |
|--|---|---|
| SELF-RECOVERY WINCH (CONT) | | |
| 3. WINCH WILL NOT REVERSE. | | |
| | Step 1. Check shift linkage for loose, damaged, or missing parts. | Tighten loose parts. Replace damaged or missing parts (para 19-3). |
| | Step 2. Check hydraulic lines for loose or damaged fittings. | Tighten loose fittings. Replace damaged fittings. Add oil as required (LO 9-2320-279-12). |
| | Step 3. Check winch control valve for damage or leaks. | If damaged or leaking, notify the supervisor. |
| 4. WINCH WILL NOT PULL LOAD. | | |
| | Step 1. Check hydraulic pump for leaks, loose, or damaged hose connections. | Tighten loose connections. Add oil as required (LO 9-2320-279-12). If hoses are damaged, notify the supervisor. |
| HEAVY-DUTY WINCH | | |
| 1. WINCH CABLE WILL NOT PAY OUT (M984). | | |
| | Step 1. Check if crane operates (TM 9-2320-279-10). | If crane does not operate, go to HYDRAULIC SYSTEM Troubleshooting, then return here if problem is not solved. |
| | | |
| TA1 88041 | | |

Troubleshooting Malfunctions (Cont)
 Table 2-9. Troubleshooting **(Cont)**

Malfunction

Test or Inspection

Corrective Action

HEAVY-DUTY WINCH **(CONT)**

1. WINCH CABLE WILL NOT PAY OUT **(M984) (CONT)**.

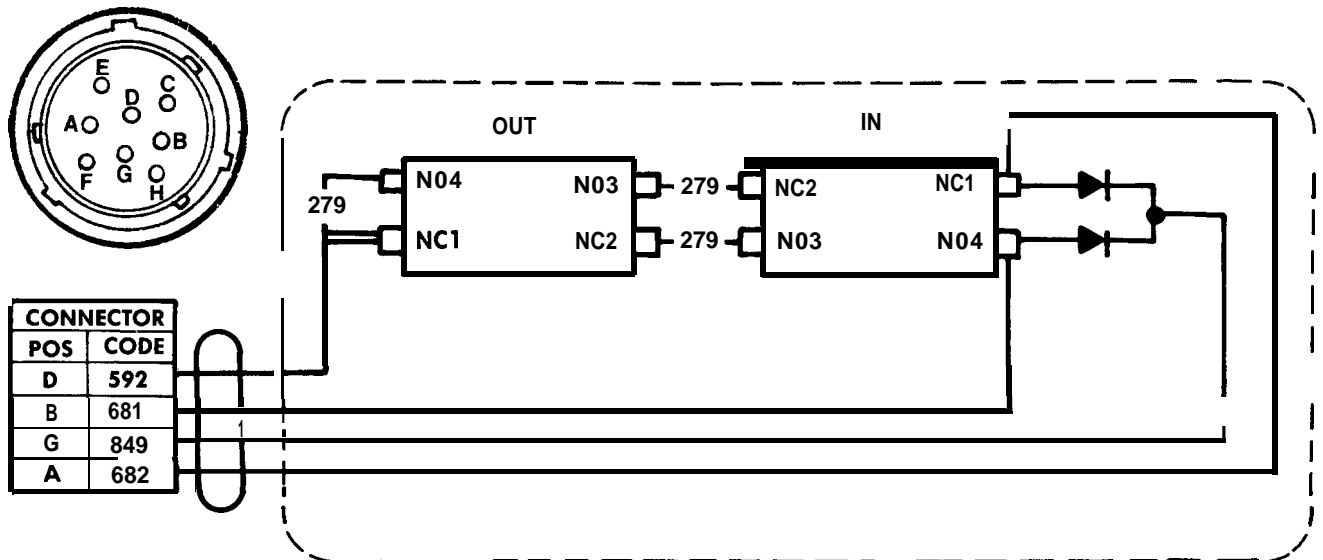
Step 2. Test for defective winch controller. Test resistance between cable connector sockets A and D when pressing OUT switch on controller.

If resistance is zero ohms, go to Step 6.

If resistance is more than zero ohms, go to Step 3.

Step 3. Remove controller cover. Test resistance on wire No. 682 between connector socket A and IN switch terminal NC1.

If resistance is more than zero ohms on either wire, replace defective wire (para 17-24 and fig. 2-8).



TA 188038

Figure 2-8. Winch Controller Wiring Diagram.

Troubleshooting Malfunctions (Cent)

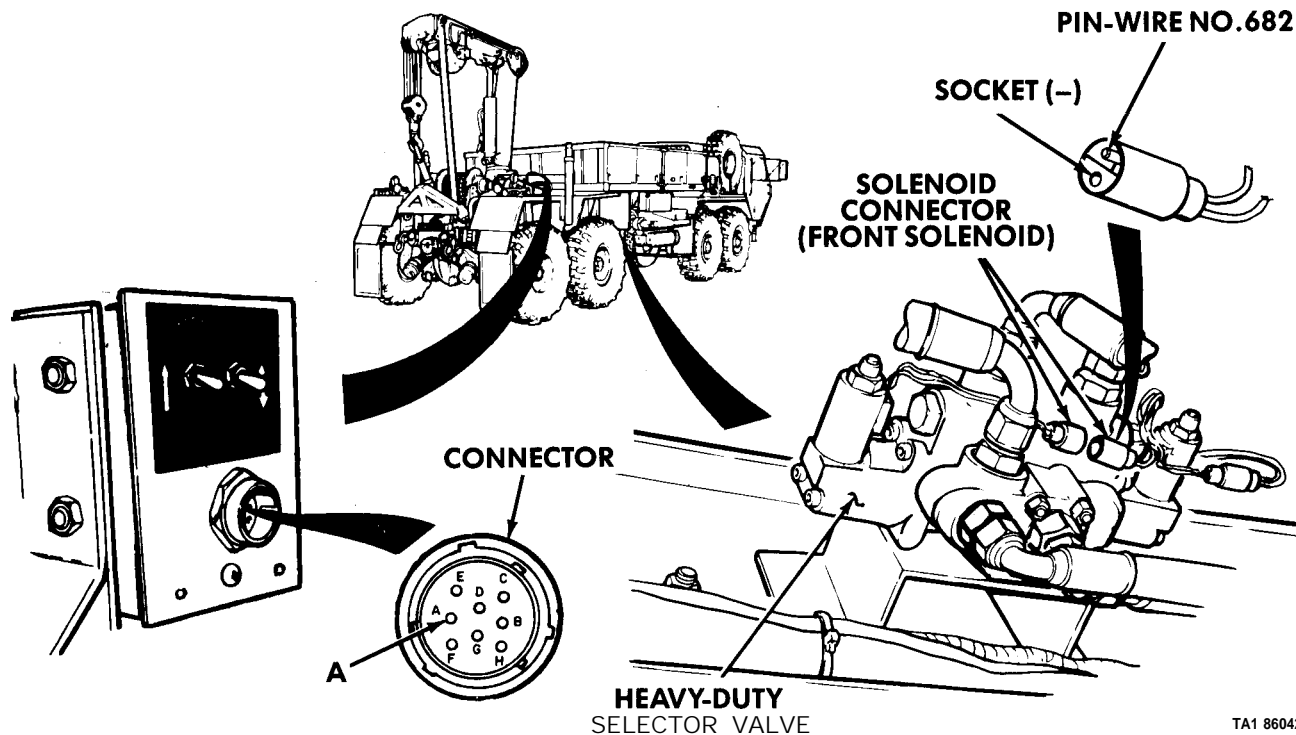
2-15. TROUBLESHOOTING INSTRUCTIONS (CONT).

Table 2-9. Troubleshooting (Cent)

| Malfunction | Test or Inspection | Corrective Action |
|-------------|--------------------|-------------------|
|-------------|--------------------|-------------------|

HEAVY-DUTY WINCH (CONT)

1. WINCH CABLE WILL NOT PAY OUT (M984)(CONT).



TA1 86042

Step 4. Check resistance of wire No. 682 from high idle box connector pin A to pin in male solenoid connector.

If resistance is more than zero ohms, replace wire No. 682 (para 17-24).

Step 5. Check resistance of wire from male solenoid connector socket to vehicle ground.

If resistance is more than zero ohms, replace wire.

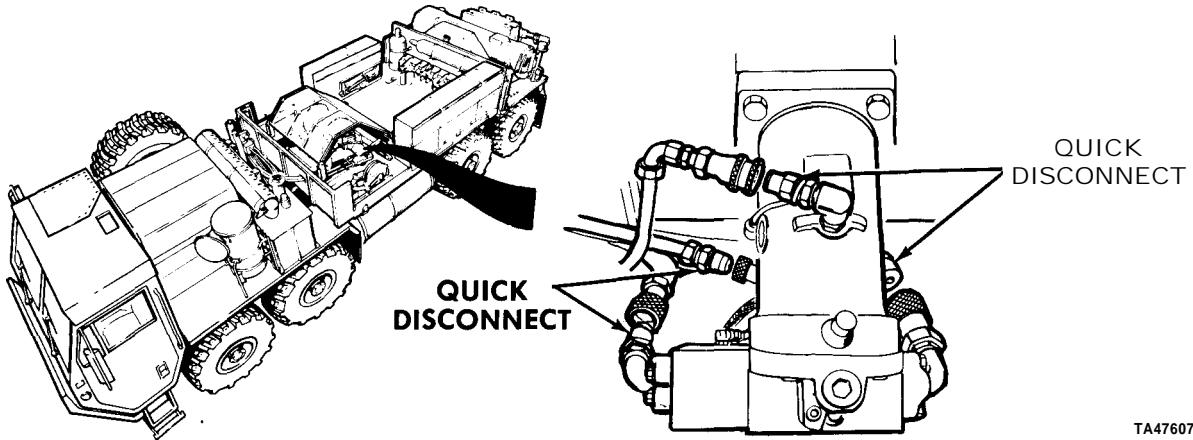
Step 6. Check for defective heavy-duty selector valve. Connect winch controller (TM 9-2320-279-10). Set ENGINE and PTO ENGAGE switches to ON. Press OUT switch on winch controller and listen for clicking sound at valve.

If clicking sound is not heard, replace heavy-duty selector valve (para 19-1 1).

Step 7. Remove hydraulic lines from motor valve and heavy-duty selector valve. Check hydraulic lines for dirt, debris, and damage.

Remove dirt and debris. Replace damaged line.

Troubleshooting Malfunctions (Cont)
Table 2-9. Troubleshooting (Cont)

| Malfunction | Test or Inspection | Corrective Action |
|---|--------------------|-------------------|
| HEAVY-DUTY WINCH (CONT) | | |
| . WINCH CABLE WILL NOT PAY OUT (M984) (CONT) . | | |
| Step 8. Check if heavy-duty winch cable pays out. | | |
| If heavy-duty winch cable does not pay out, notify the supervisor. | | |
| .1. WINCH CABLE WILL NOT PAY OUT (M984E1) . | | |
|  <p style="text-align: right; margin-right: 50px;">QUICK DISCONNECT</p> <p style="text-align: center;">QUICK DISCONNECT</p> <p style="text-align: right;">TA476070</p> | | |
| Step 1. Check winch motor quick disconnects for proper connection or damage. Fully engage quick disconnects or repair damaged quick disconnects. | | |
| Step 2. Check if crane operates (TM 9-2320-279-10). If crane does not operate, go to MATERIAL HANDLING CRANE Troubleshooting, Malfunction 1, then return here if problem is not solved. | | |

Troubleshooting Malfunctions (Cent)

12-15. TROUBLESHOOTING INSTRUCTIONS (CONT.)

Table 2-9. Troubleshooting (Cent)

| Malfunction | Test or Inspection | Corrective Action |
|--|--------------------|-------------------|
| HEAVY-DUTY WINCH (CONT) | | |
| 1.1. WINCH CABLE WILL NOT PAY OUT (M984E1) (CONT). | | |
| | | |
| TA476170 | | |
| Step 3. Operate winch from manual station (TM 9-2320-279-10). Check if winch cable will pay out. | | |
| If winch cable will pay out, go to step 4. | | |
| If winch cable will not pay out, go to step 6. | | |
| Step 4. Operate heavy-duty winch in the remote control position (TM 9-2320-279-10). Check for 24 VDC at pin D. | | |
| If 24 VDC is not present, go to ENGINE Troubleshooting Malfunction 9.1, then return here. | | |
| | | |
| TA476171 | | |

Troubleshooting Malfunctions (Cent)
Table 2-9. Troubleshooting (Cent)

| Malfunction | Test or Inspection | Corrective Action |
|--|--------------------|-------------------|
| HEAVY-DUTY WINCH (CONT) | | |
| 1.1. WINCH CABLE WILL NOT PAY OUT (M984E1) (CONT) . | | |
| <p>Step 5. Set fail-safe switch to ON position. Engage winch OUT. Check resistance between terminals B and D.</p> | | |
| <p style="text-align: center;">If resistance is more than 15 ohms, replace remote controller.</p> | | |
| <p>The diagram illustrates the electrical connection for a heavy-duty winch. It shows a truck with a winch, a fail-safe valve connector, and an electrical control box. The control box has terminals labeled A, B, C, D, and E. A label 'CONTACT 2 (WIRE 854)' points to terminal E. Another label 'FAIL-SAFE VALVE' points to a connector. A third label 'HEAVY-DUTY WINCH MANUAL CONTROL' points to the winch assembly. A label 'PIN C' points to terminal C. The diagram also shows a close-up of the fail-safe valve connector and the winch manual control assembly.</p> | | |
| TA476172 | | |
| <p>Step 6. Disconnect connector from fail-safe valve on heavy-duty winch forward manual control, Set all electrical switches for remote operation (TM 9-2320-279-10). Check resistance of wire 854 from contact 2 on fail-safe valve connector to pin C at electrical control box.</p> | | |
| <p style="text-align: center;">If resistance is more than zero ohms, repair wire 854 or replace fail-safe valve connector.</p> | | |

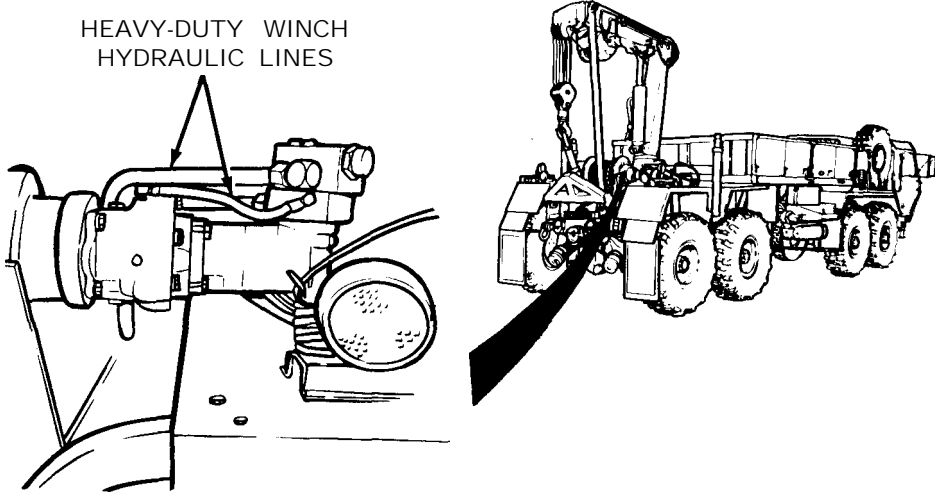
Troubleshooting Malfunctions (Cont)

12-15. TROUBLESHOOTING INSTRUCTIONS (CONT).

Table 2-9. Troubleshooting (Cont)

| Malfunction | Test or Inspection | Corrective Action |
|--|--------------------|-------------------|
| HEAVY-DUTY WINCH (CONT) | | |
| 1.1. WINCH CABLE WILL NOT PAY OUT (M984E1) (CONT). | | |
| | | |
| NOTE | | |
| Batteries must be disconnected. | | |
| <p>Step 7. Disconnect connector from winch OUT solenoid. Set all electrical switches for remote operation (TM 9-2320-279-10). Check resistance of wire 682 from contact 2 on winch OUT connector to pin B at electrical control box.</p> | | |
| <p style="padding-left: 40px;">If resistance is more than zero ohms, repair wire 682 or replace winch out connector.</p> | | |
| <p>Step 8. Check wires in remote control cable for continuity.</p> | | |
| <p style="padding-left: 40px;">If resistance is more than zero ohms, repair wire or replace connector.</p> | | |
| <p style="padding-left: 40px;">If problem remains, notify the supervisor.</p> | | |

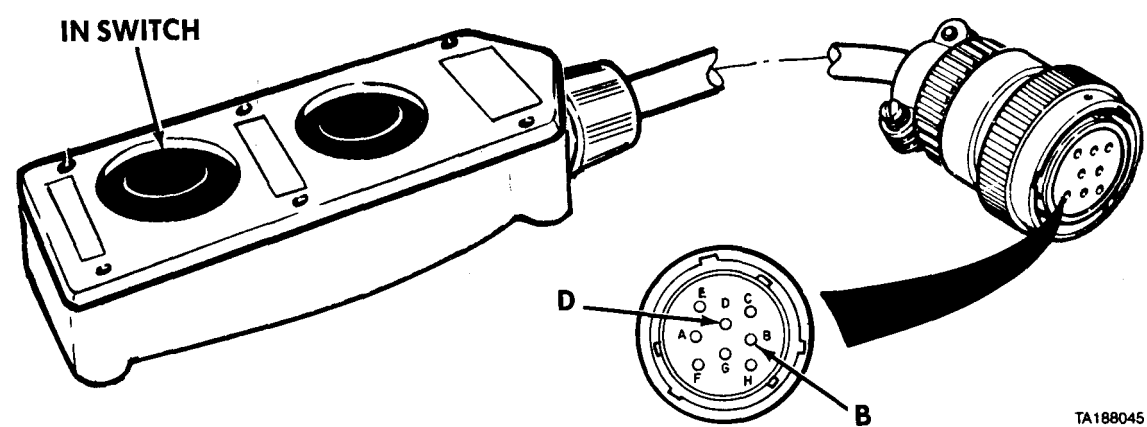
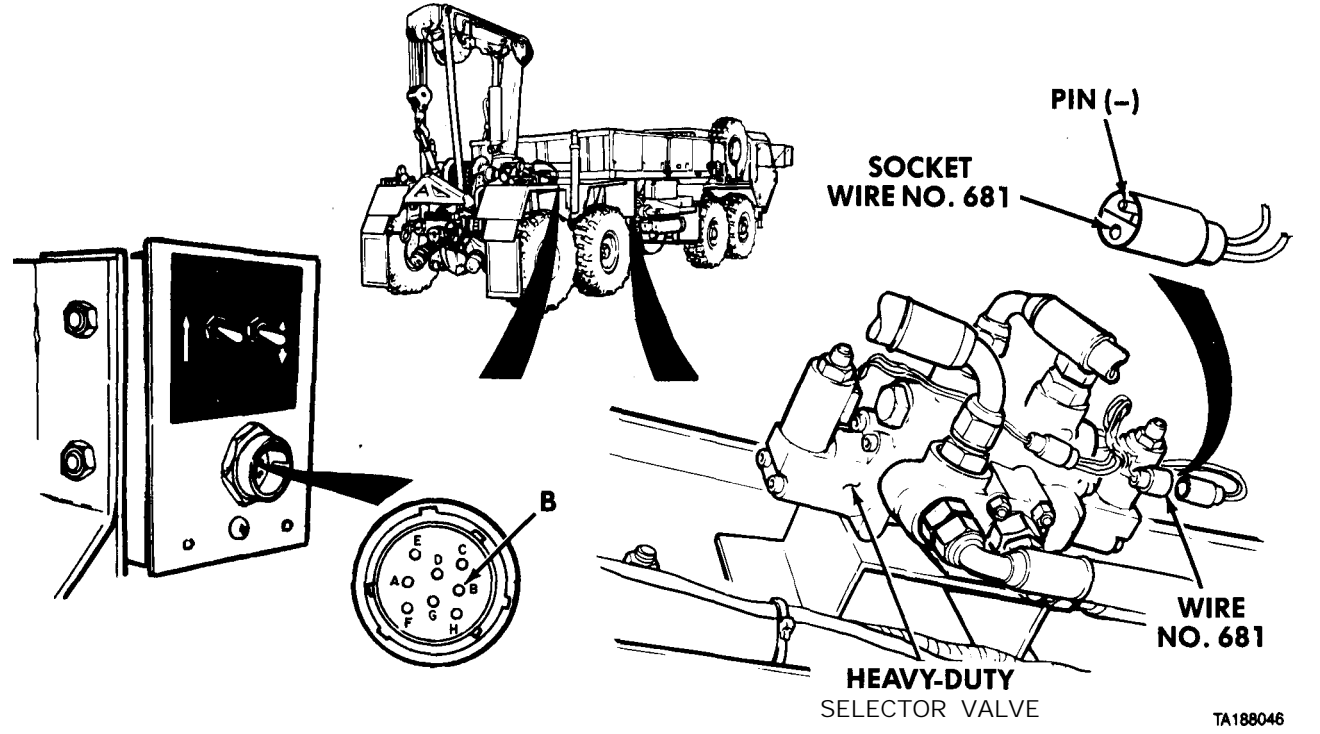
Troubleshooting Malfunctions (Cont)
Table 2-9. Troubleshooting (Cont)

| Malfunction | Test or Inspection | Corrective Action |
|--|--------------------|-------------------|
| HEAVY-DUTY WINCH (CONT) | | |
| 2. WINCH WILL NOT REWIND (M984). | | |
| Step 1. Refer to HYDRAULIC SYSTEM Troubleshooting. | | |
| If problem remains, go to Step 2. | | |
| HEAVY-DUTY WINCH HYDRAULIC LINES | | |
|  | | |
| TA188044 | | |
| Step 2. Check heavy-duty winch hydraulic lines for damage. | | |
| Replace damaged hydraulic lines. | | |
| Step 3. Remove hydraulic lines from heavy-duty winch selector valve (para 19-11). Check for blocked lines. | | |
| Clean lines. | | |

Troubleshooting Malfunctions (Cent)

12-15. TROUBLESHOOTING INSTRUCTIONS (CONT.)

Table 2-9. Troubleshooting (Cent)

| Malfunction | Test or Inspection | Corrective Action |
|---|---|-------------------|
| HEAVY-DUTY WINCH (CONT) | | |
| 2. WINCH WILL NOT REWIND (M984) (CONT). |  | TA188045 |
| <p>Step 4. Test for defective winch controller. Test resistance between cable connector sockets B and D when pressing IN switch on controller.</p> <p>If resistance is more than zero ohms, go to Step 8.</p> | | |
|  | | |
| TA188046 | | |

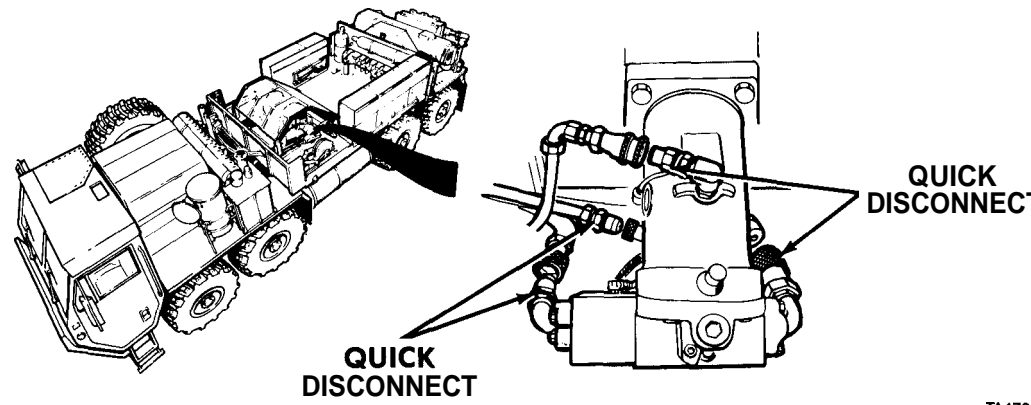
Troubleshooting Malfunctions (Cont)
Table 2-9. Troubleshooting (Cont)

| Malfunction | Test or Inspection | Corrective Action |
|--|--|--|
| HEAVY-DUTY WINCH (CONT) | | |
| 2. WINCH WILL NOT REWIND (M984) (CONT). | | |
| | <p>Step 5. Check resistance of wire No. 681 from high idle box connector pin B to socket in male solenoid connector.</p> | <p>If resistance is more than zero ohms, replace wire No. 681 (para 17-24).</p> |
| | <p>Step 6. Check resistance of wire from male solenoid connector pin to vehicle ground.</p> | <p>If resistance is more than zero ohms, replace wire.</p> |
| | <p>Step 7. Check for defective heavy-duty selector valve. Connect controller. Set ENGINE and PTO ENGAGE switches to ON. Press IN switch on remote controller and listen for clicking sound at valve.</p> | <p>If clicking sound is not heard, replace heavy-duty selector valve (para 19-1 1).</p> |
| | | |
| | <p>Step 8. Remove controller cover (para 17-24). Test resistance on wire No. 681 between connector socket B and IN switch terminal No. 4.</p> | <p>If resistance is more than zero ohms, replace defective wire No. 681 (para 17-24 and fig. 2-8).</p> |
| | <p>Step 9. Check if heavy duty winch will pull load.</p> | <p>If heavy-duty winch will not pull load, notify the supervisor.</p> |

Troubleshooting Malfunctions (Cent)

2-15. TROUBLESHOOTING INSTRUCTIONS (CONT).

Table 2-9. Troubleshooting (Cent)

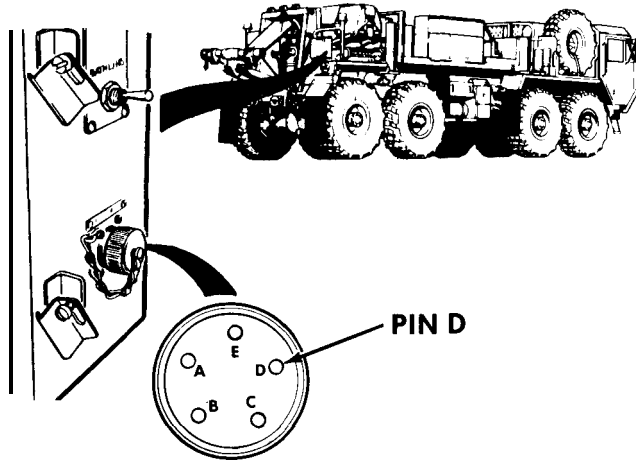
| Malfunction Test or Inspection | Corrective Action |
|--|-------------------|
| HEAVY-DUTY WINCH (CONT) | |
| <p>2.1. WINCH WILL NOT REWIND (M984E1).</p> | |
|  <p style="text-align: right;">TA476074</p> | |
| <p>Step 1. Check winch motor quick disconnects for proper connection or damage. Fully engage quick disconnects or repair damaged quick disconnects.</p> | |
| <p>Step 2. Check if crane operates (TM 9-2320-279-10). If crane does not operate, go to MATERIAL HANDLING CRANE Troubleshooting, MALFUNCTION 1, then return here if problem is not solved.</p> | |
| <p>Step 3. Operate winch from manual station. If winch will rewind, go to Step 4. If winch will not rewind, go to Step 6.</p> | |

Troubleshooting Malfunctions (Cont)
Table 2-9. Troubleshooting (Cont)

| Malfunction | Test or Inspection | Corrective Action |
|-------------|--------------------|-------------------|
|-------------|--------------------|-------------------|

HEAVY-DUTY WINCH (CONT)

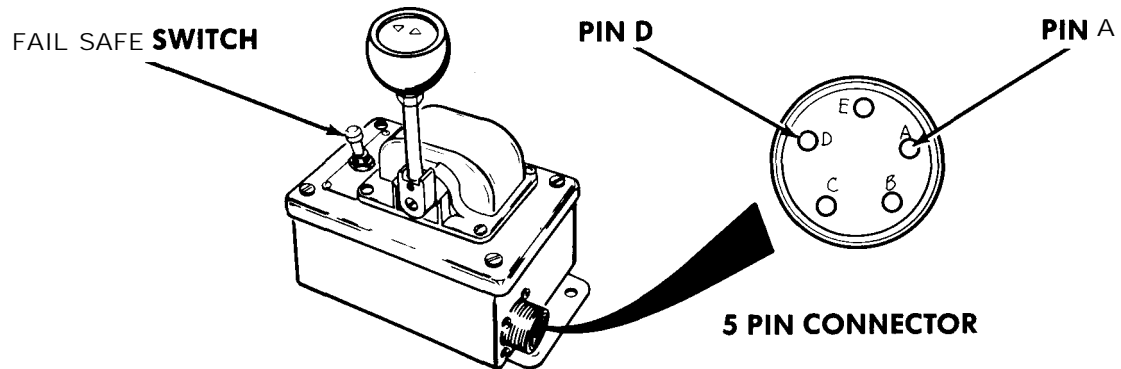
2.1. WINCH WILL NOT REWIND (M984E1) (CONT).



TA476071

Step 4. Operate heavy-duty winch in the remote control position (TM 9-2320-279-10). Check for 24 VDC at pin D.

If 24 VDC is not present, go to ENGINE Troubleshooting, MALFUNCTION 9.1, then return here.



TA476077

Step 5. Check for defective remote controller. Set fail-safe switch to ON. Engage winch in. Check resistance between pin A and pin D.

If resistance is more than 15 ohms, replace remote controller.

Troubleshooting Malfunctions (Cont)

12-15. TROUBLESHOOTING INSTRUCTIONS (CONT).

Table 2-9. Troubleshooting (Cont)

| Malfunction | Test or Inspection | Corrective Action |
|--|--------------------|-------------------|
| HEAVY-DUTY WINCH (CONT) | | |
| 2.1. WINCH WILL NOT REWIND (M984E1) (CONT). | | |
| <p>The diagram illustrates the electrical circuit for a heavy-duty winch. On the left, a control panel features a switch labeled 'WINCH IN' and a terminal block with five pins labeled A, B, C, D, and E. A circular terminal block is shown with these pins. A connector labeled 'CONTACT 2 (WIRE 681)' is connected to pin A. This connector is also shown connected to the 'WINCH IN SOLENOID' assembly on the right. A truck with a winch is shown in the background, with a line indicating the winch's location.</p> <p style="text-align: right;">TA476072</p> | | |
| <p>Step 6. Check for defective winch IN solenoid wiring. Disconnect connector from winch IN solenoid at heavy-duty winch forward manual control. Set all electrical switches for remote operation (TM 9-2320-279-10). Check resistance of wire 681 from contact 2 on winch IN connector to pin A at electrical control box. Reinstall connector on winch IN solenoid.</p> | | |
| <p style="padding-left: 40px;">If resistance is more than zero ohms, repair wire 681 or replace winch in connector.</p> | | |

Troubleshooting Malfunctions (Cont)
Table 2-9. Troubleshooting (Cont)

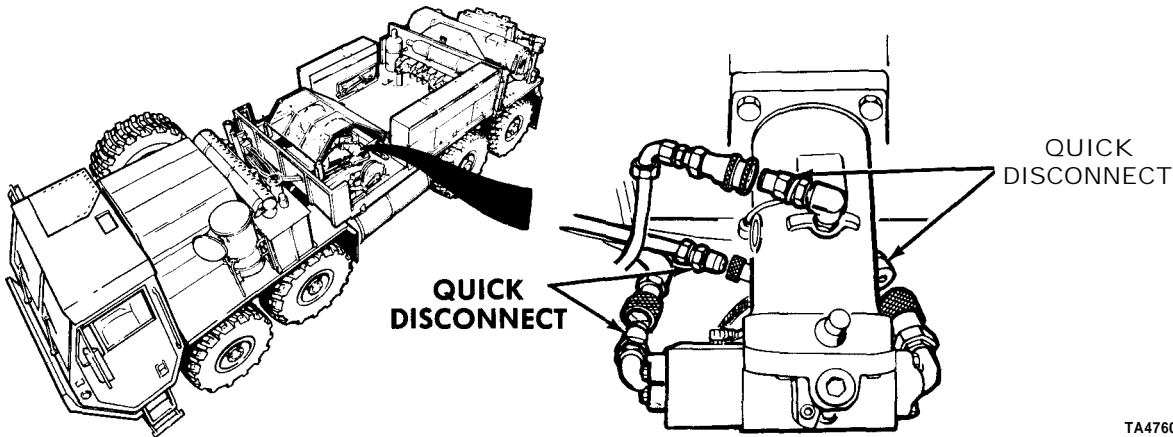
| Malfunction | Test or Inspection | Corrective Action |
|---|--------------------|-------------------|
| HEAVY-DUTY WINCH (CONT) | | |
| 2.1. WINCH WILL NOT REWIND (M984E1) (CONT). | | |
| <p>The diagram illustrates the electrical and mechanical components for a heavy-duty winch. At the top center is a side view of a truck with a winch mounted on its front. To the right is a detailed view of a fail-safe solenoid valve with a label 'FAIL-SAFE SOLENOID VALVE'. Below the truck is a circular electrical control box with five terminals labeled A, B, C, D, and E. A label 'CONTACT 2' points to terminal C. To the left of the control box is a label 'PIN C' with an arrow pointing to terminal C. Below the control box is a label 'HEAVY-DUTY WINCH FORWARD MANUAL CONTROL'. On the far left, there are two smaller diagrams showing electrical connectors and a switch mechanism.</p> | | |
| <p>Step 7. Check for defective fail-safe solenoid wiring. Disconnect connector from fail-safe solenoid valve. Set all electrical switches for remote operation (TM 9-2320-279-10). Check resistance of wire 854 from contact 2 on fail-safe valve connector to pin C at electrical control box.</p> | | |
| <p style="padding-left: 40px;">If resistance is more than zero ohms, repair wire or replace connector.</p> | | |
| <p>Step 8. Check wires in remote control cable for continuity.</p> | | |
| <p style="padding-left: 40px;">If resistance is more than zero ohms, repair wire or replace connector.</p> | | |
| <p style="padding-left: 40px;">If problem remains, notify the supervisor.</p> | | |

TA476073

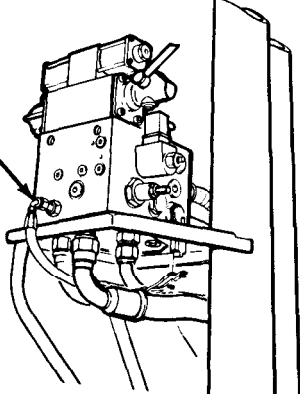
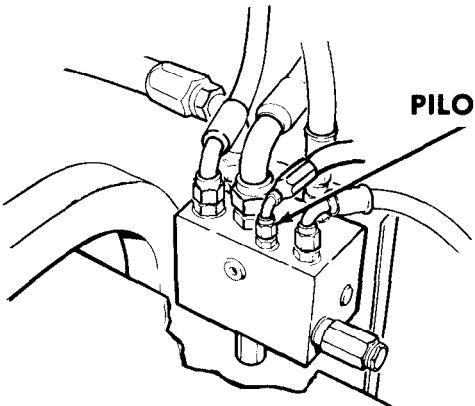
Troubleshooting Malfunctions (Cent)

12-15. TROUBLESHOOTING INSTRUCTIONS (CONT).

Table 2-9. Troubleshooting (Cent)

| Malfunction |
|--|
| Test or Inspection |
| Corrective Action |
| <p>HEAVY-DUTY WINCH (CONT)</p> |
| <p>2.2. WINCH WILL NOT OPERATE IN EITHER DIRECTION (M984E1).</p> |
| <p>Step 1. Refer to HYDRAULIC SYSTEM Troubleshooting.</p> |
|  <p>The diagram consists of two parts. On the left is a perspective view of a truck with a winch mounted on its bed. A beam of light from a flashlight illuminates the winch. On the right is a detailed view of the winch's hydraulic motor. Two hydraulic hoses are connected to the motor, and each connection is labeled with the text 'QUICK DISCONNECT' and an arrow pointing to the fitting.</p> |
| <p>TA476070</p> |
| <p>Step 2. Check winch motor quick disconnects for proper installation or damage. Fully engage quick disconnects or repair damaged quick disconnects.</p> |
| <p>Step 3. If problem remains, notify the supervisor.</p> |
| <p>3. WINCH MAKES EXCESSIVE OR UNUSUAL NOISE (M984).</p> |
| <p>Step 1. Check hydraulic oil level (LO 9-2320-279-12). Replenish oil.</p> |
| <p>Step 2. Inspect winch hydraulic motor for loose mounting and leaks. Tighten loose mountings. Tighten hydraulic connections or notify the supervisor if leaks are from winch.</p> |
| <p>Step 3. Check for excessive noise from winch. Notify the supervisor.</p> |

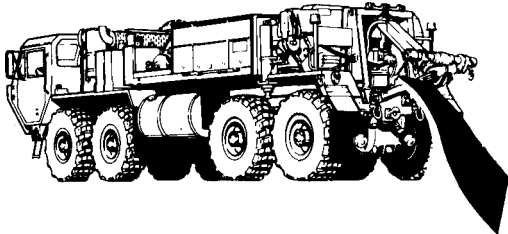
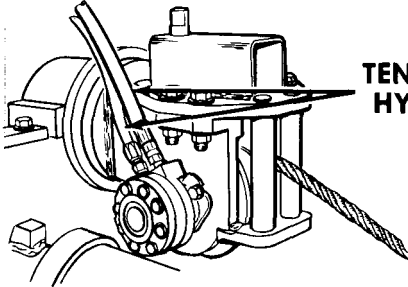
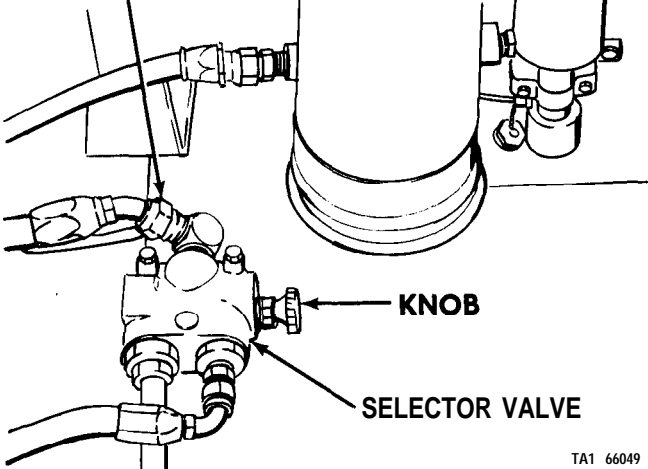
Troubleshooting Malfunctions (Cont)
 Table 2-9. Troubleshooting (Cont)

| Malfunction | Test or Inspection | Corrective Action |
|--|--|--|
| HEAVY-DUTY WINCH (CONT) | | |
| 4. WINCH OPERATION IS JERKY, SLOW, OR DOES NOT WORK (M984). | <p>Step 1. Refer to HYDRAULIC SYSTEM Troubleshooting. If problem remains, go to Step 2.</p> | <p>Step 2. Check for loose line connections and fittings at heavy-duty winch motor and brake. Tighten loose lines and fittings. Replenish oil as required (LO 9-2320-279-12).</p> |
| NOTE | | |
| Motor will normally be hot during heavy use. | | |
| Step 3. Check heavy-duty winch motor for overheating and unusual noise. | <p>If heavy-duty winch motor is smoking, hot, or makes unusual noise, notify the supervisor.</p> | |
| 5. FAIRLEAD TENSIONER MOTOR DOES NOT OPERATE (M984E1). | | |
| PILOT LINE |  | PILOT LINE |
|  | | |
| TA476075 | | |
| Step 1. Check for loose connections, damaged or kinked pilot line. | <p>Tighten loose connections, repair damaged or kinked pilot line.</p> | |

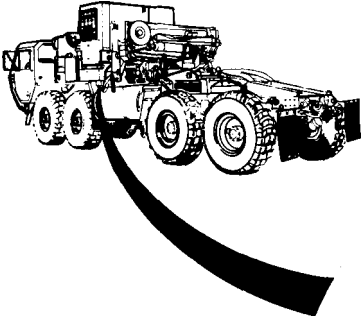
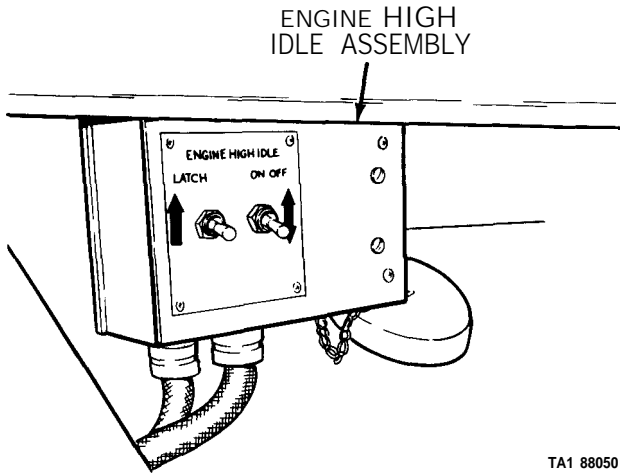
Troubleshooting Malfunctions (Cent)

12-15. TROUBLESHOOTING INSTRUCTIONS (CONT).

Table 2-9. Troubleshooting (Cent)

| Malfunction | Test or Inspection | Corrective Action |
|---|--|---|
| HEAVY-DUTY WINCH (CONT) | | |
| 5. FAIRLEAD TENSIONER MOTOR DOES NOT OPERATE (M984E1) (CONT). | | |
|  |  | <p>TENSIONER MOTOR HYDRAULIC LINES</p> |
| TA476076 | | |
| <p>Step 2. Check for loose connections, damaged or kinked hydraulic hoses. Tighten loose connections, repair damaged or kinked hydraulic hoses.</p> <p>Step 3. If problem has not been solved, notify the supervisor.</p> | | |
| MATERIAL HANDLING CRANE (M983) | | |
| 1. CRANE DOES NOT FUNCTION. | | |
| <p>CONNECTING LINES</p> |  | <p>KNOB</p> <p>SELECTOR VALVE</p> |
| TA1 66049 | | |

Troubleshooting Malfunctions (Cont)
Table 2-9. Troubleshooting (Cont)

| Malfunction | Test or Inspection | Corrective Action |
|--|--|--|
| MATERIAL HANDLING CRANE (M983) (CONT) | | |
| 1. CRANE DOES NOT FUNCTION (CONT) . | Step 1. Check position of selector valve on fender (TM 9-2320-279-10). | Put selector valve in proper position (TM 9-2320-279-10). |
| | Step 2. Check selector valve for leaks or damage. | Replace selector valve if leaking or damaged (para 19-14). |
| | Step 3. Go to HYDRAULIC SYSTEM Troubleshooting and make checks shown for MALFUNCTIONS 1 and 2. | |
| 2. CRANE BOOM MOVES SLOWLY. | | |
|  |  | TA1 88050 |
| | Step 1. Check that ENGINE HIGH IDLE assembly changes engine speed to 1500 ± 50 rpm when engaged (TM 9-2320-279-10). | If engine speed does not increase to 1500 ± 50 rpm, refer to ENGINE Troubleshooting, MALFUNCTION 6, ENGINE HIGH IDLE DOES NOT OPERATE. |
| | Step 2. Go to HYDRAULIC SYSTEM Troubleshooting and make checks shown for MALFUNCTIONS 1 and 2. Return to this section if problem is not fixed. | |

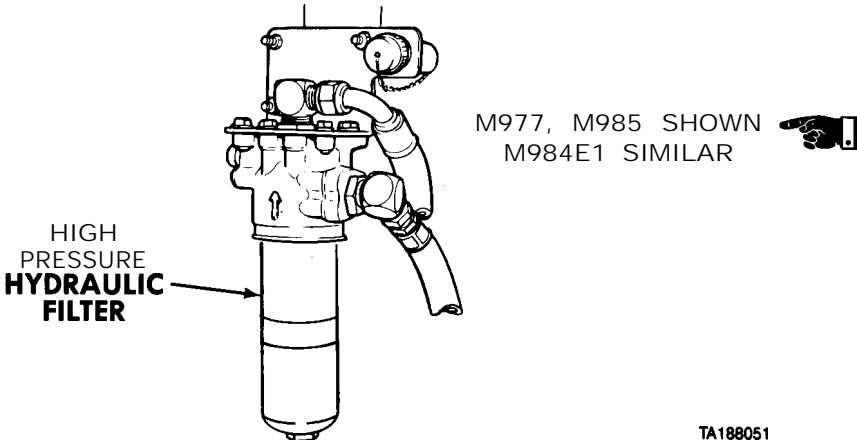
Troubleshooting Malfunctions (Cont)

2-15. TROUBLESHOOTING INSTRUCTIONS (CONT).

Table 2-9. Troubleshooting (Cont)

| Malfunction | Test or Inspection | Corrective Action |
|---|--------------------|-------------------|
| MATERIAL HANDLING CRANE (M983) (CONT) | | |
| 2. CRANE BOOM MOVES SLOWLY (CONT). | | |
| | | |
| <p>Step 3. Check for plugged strainers or filter. Clean or replace top strainer or filter (para 13-11).</p> <p>Step 4. Check hydraulic lines from hydraulic pump to crane for looseness or damage, starting at crane connections. Tighten loose connections, add oil as required (LO 9-2320-279-12). If lines are damaged, notify the supervisor.</p> <p>Step 5. If problem has not been solved, notify the supervisor.</p> | | |
| 3. OUTRIGGER CYLINDERS WILL NOT RETRACT. | | |
| <p>Step 1. Check for loose or damaged hydraulic lines. Tighten loose lines, add oil as required (LO 9-2320-279-12). If lines are damaged, notify the supervisor.</p> <p>Step 2. If problem remains, notify the supervisor.</p> | | |
| MATERIAL HANDLING CRANE (M977, M985, M984E1) | | |
| 1. CRANE WILL NOT OPERATE. | | |
| <p>Step 1. Check for faulty hydraulic system operation. Refer to HYDRAULIC SYSTEM Troubleshooting.</p> | | |

Troubleshooting Malfunctions (Cont)
 Table 2-9. Troubleshooting **(Cont)**

| Malfunction | Test or Inspection | Corrective Action |
|--|--------------------|-------------------|
| MATERIAL HANDLING CRANE (M977, M985, M984E 1) (CONT) | | |
| 1. CRANE WILL NOT OPERATE (CONT). | | |
| <p>Step 2. Check for defective power takeoff (PTO) operation.</p> | | |
| <p style="text-align: center;">Refer to ELECTRICAL SYSTEM Troubleshooting, MALFUNCTION 4, POWER TAKEOFF (PTO) SWITCH WILL NOT ENGAGE.</p> | | |
| 2. OUTRIGGER OPERATION SLOW OR ABNORMAL OR OUTRIGGERS WILL NOT EXTEND OR RETRACT. | | |
| <p>Step 1. Check that ENGINE HIGH IDLE assembly increases engine speed to 1500 ± 50 rpm (TM 9-2320-279-10).</p> | | |
| <p style="text-align: center;">If engine speed does not increase to 1500 ± 50 rpm refer to ENGINE Troubleshooting, MALFUNCTION 6, ENGINE HIGH IDLE DOES NOT OPERATE.</p> | | |
|  | | |
| <p style="text-align: right;">TA188051</p> | | |
| <p>Step 2. Check for clogged high pressure hydraulic filter (para 19-17).</p> | | |
| <p style="text-align: center;">Service high pressure hydraulic filter(para 19-17).</p> | | |
| <p>Step 3. Check for faulty hydraulic system operation.</p> | | |
| <p style="text-align: center;">Refer to HYDRAULIC SYSTEM Troubleshooting.</p> | | |
| 3. MAST RAISES OR LOWERS ABNORMALLY, SLOWLY, OR WILL NOT RAISE OR LOWER. | | |
| <p>Step 1. Check that ENGINE HIGH IDLE assembly increases engine speed to 1500 ± 50 rpm (TM 9-2320-279-10).</p> | | |
| <p style="text-align: center;">If engine speed does not increase to 1500 ± 50 rpm, refer to ENGINE Troubleshooting, MALFUNCTION 6, ENGINE HIGH IDLE DOES NOT OPERATE.</p> | | |
| <p>Step 2. Check for clogged high pressure hydraulic filter (para 19-17).</p> | | |
| <p style="text-align: center;">Service high pressure hydraulic filter(para 19-17).</p> | | |

Troubleshooting Malfunctions (Cont)

2-15. TROUBLESHOOTING INSTRUCTIONS (CONT).

Table 2-9. Troubleshooting (Cont)

| Malfunction Test or Inspection | Corrective Action |
|--|--|
| MATERIAL HANDLING CRANE (M977, M985, M984E1) (CONT) | |
| 3. MAST RAISES OR LOWERS ABNORMALLY, SLOWLY, OR WILL NOT RAISE OR LOWER (CONT). | Step 3. Check for faulty hydraulic system operation. Refer to HYDRAULIC SYSTEM Troubleshooting. |
| 4. BOOM OPERATES ABNORMALLY, SLOWLY, WILL NOT TELESCOPE IN OR OUT, OR RAISE OR LOWER. | Step 1. Check that ENGINE HIGH IDLE assembly increases engine speed to 1500 ± 50 rpm (TM 9-2320-279-10). If engine speed does not increase to 1500 ± 50 rpm, refer to ENGINE Troubleshooting, MALFUNCTION 6, ENGINE HIGH IDLE WILL NOT OPERATE. |
| | |
| Step 2. Check for loose or damaged overload sensors. | If overload sensors are loose or damaged, notify supervisor. |

Troubleshooting Malfunctions (Cent)

Table 2-9. Troubleshooting (Cent)

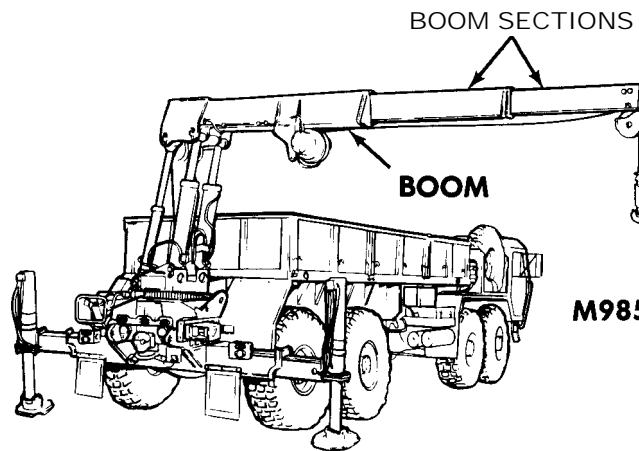
Malfunction

Test or Inspection

Corrective Action

MATERIAL HANDLING CRANE (M977, M985, M984E 1) (CONT)

4. BOOM OPERATES ABNORMALLY, SLOWLY, WILL NOT TELESCOPE IN OR OUT, OR RAISE OR LOWER (CONT).

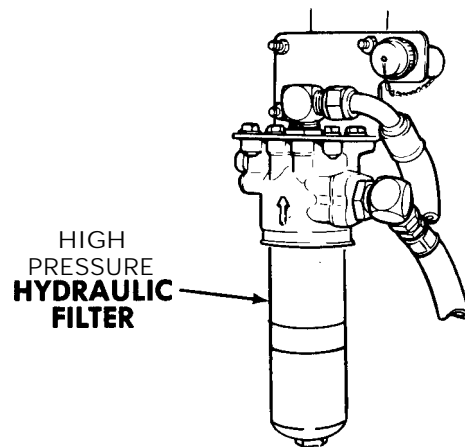


M977 SHOWN
M985, M984E1 SIMILAR

TA188056

Step 3. If boom operates abnormally, check for dry boom sections.

TELESCOPE boom OUT. Check lubrication in boom sections. Lubricate dry sections (LO 9-2320-279-12).



M977, M985 SHOWN
M984E1 SIMILAR

TA18S051

Step 4. Check for clogged high pressure hydraulic filter (para 19-17).

Service high pressure hydraulic filter (para 19-17).

Step 5. Check for faulty hydraulic system operation.

Refer to HYDRAULIC SYSTEM Troubleshooting.

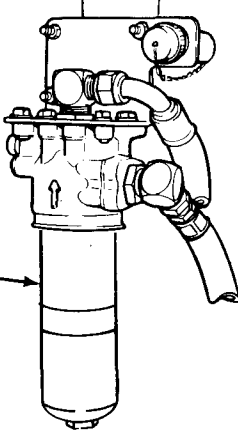
Troubleshooting Malfunctions (Cont)

2-15. TROUBLESHOOTING INSTRUCTIONS (CONT)

Table 2-9. Troubleshooting (Cont)

| Malfunction Test or Inspection | Corrective Action |
|---|--|
| MATERIAL HANDLING CRANE (M977, M985, M984E1) (CONT) | |
| 5. HOIST WILL NOT LIFT OR LOWER LOAD. | |
| <div style="display: flex; justify-content: space-around; align-items: center;"> <div data-bbox="330 883 495 946" style="text-align: center;"> <p>OVERLOAD SENSORS</p> </div> <div data-bbox="437 638 991 1074"> </div> <div data-bbox="842 638 1189 712" style="text-align: center;"> <p>M977 SHOWN M985, M984E1 SIMILAR</p> </div> </div> | |
| Step 1. | Check for loose overload sensors. |
| If overload sensors are loose, notify the supervisor. | |
| Step 2. | Check for faulty hydraulic system operation. |
| Refer to HYDRAULIC SYSTEM Troubleshooting. | |
| If problem remains, notify the supervisor. | |

Troubleshooting Malfunctions (Cont)
 Table 2-9. Troubleshooting (Cont)

| Malfunction | Test or Inspection | Corrective Action |
|---|--------------------|-------------------|
| MATERIAL HANDLING CRANE (M977, M985, M984E1) (CONT) | | |
| 5. HOIST OPERATION SLOW OR ABNORMAL WHEN LIFTING OR LOWERING LOAD. | | |
| Step 1. Check that ENGINE HIGH IDLE assembly increases engine speed to 1500 ± 50 rpm (TM 9-2320-279-10). | | |
| If engine speed does not increase to 1500 ± 50 rpm, refer to ENGINE Troubleshooting, MALFUNCTION 6, ENGINE HIGH IDLE DOES NOT OPERATE. | | |
| Step 2. Check for faulty hydraulic system operation. | | |
| Refer to HYDRAULIC SYSTEM Troubleshooting. | | |
| If problem remains, notify the supervisor. | | |
|  <p data-bbox="933 991 1224 1051">M977, M985 SHOWN M984E1 SIMILAR</p> <p data-bbox="465 1102 629 1208">HIGH PRESSURE HYDRAULIC FILTER</p> <p data-bbox="1158 1306 1224 1325">TA188051</p> | | |
| Step 3. Check for clogged high pressure hydraulic filter (para 19-17). | | |
| Service filter (para 19-17). | | |

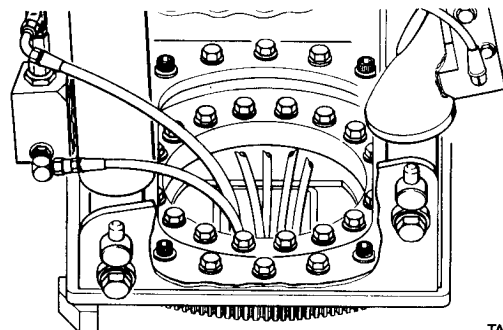
Troubleshooting Malfunctions (Cont)

2-15. TROUBLESHOOTING INSTRUCTIONS (CONT).

Table 2-9. Troubleshooting (Cont)

| Malfunction | Test or Inspection | Corrective Action |
|---|--------------------|---|
| MATERIAL HANDLING CRANE (M977, M985) (CONT) | | |
| 6. HOIST OPERATION SLOW OR ABNORMAL WHEN LIFTING OR LOWERING LOAD (CONT). | | <div data-bbox="383 697 1212 1159" data-label="Image"> </div> <p data-bbox="705 1212 865 1251" style="text-align: center;"><u>WARNING</u></p> <p data-bbox="252 1266 1318 1393">Do not try to loosen fittings in pressurized lines or while engine is running and PTO is engaged. Oil is under high pressure. Spray can cause blindness or other injury. Fittings may blow off unexpectedly when loose, causing injury. Always shut off engine before loosening fittings.</p> <p data-bbox="184 1415 756 1457">Step 4. Check for air trapped in hoist brake.</p> <p data-bbox="411 1457 1453 1691">Loosen screw in top of air bleeder valve. Start engine, set PTO ENGAGE and crane POWER switches to ON. Operate HOIST control and bleed trapped air from hoist brake. Shut OFF crane POWER, PTO ENGAGE, and ENGINE switches, and shut off engine. Remove fill plug. Start vehicle (TM 9-2320-279-10), set PTO ENGAGE switch to ON, set crane POWER switch to ON, operate HOIST control, and bleed about 1 qt (1 L) of oil and air from hoist brake, then fill with oil (LO 9-2320-279-12).</p> |

Troubleshooting Malfunctions (Cont)
 Table 2-9. Troubleshooting (Cont)

| Malfunction | Test or Inspection | Corrective Action |
|--|--------------------|-------------------|
| MATERIAL HANDLING CRANE (M977, M985, M984E1) (CONT) | | |
| 7. SWING OPERATION SLOW OR ABNORMAL IN ONE OR BOTH DIRECTIONS. | | |
| Step 1. Check that ENGINE HIGH IDLE assembly increases engine speed to 1500 ± 50 rpm (TM 9-2320-279-10). | | |
| If engine speed does not increase to 1500 ± 50 rpm, refer to ENGINE Troubleshooting, MALFUNCTION 6, ENGINE HIGH IDLE WILL NOT OPERATE. | | |
| Step 2. Check for faulty hydraulic sytem operation. | | |
| Refer to HYDRAULIC SYSTEM Troubleshooting. | | |
|  | | |
| TA356983 | | |
| Step 3. Check for insufficient lubrication on turntable bearing. | | |
| Lubricate turntable bearing (LO 9-2320-279-12). | | |
| Step 4. Check oil level in swing drive gear case (LO 9-2320-279-12). | | |
| Add oil if necessary (LO 9-2320-279-12). | | |
| Step 5. Check for loose or missing turntable bearing screws (Table 2-2). | | |
| Tighten turntable bearing screws (Table 2-2) and notify the supervisor if there are any missing screws. | | |
| 8. DELETED. | | |

Troubleshooting Malfunctions (Cont)
 Table 2-9. Troubleshooting (Cont)

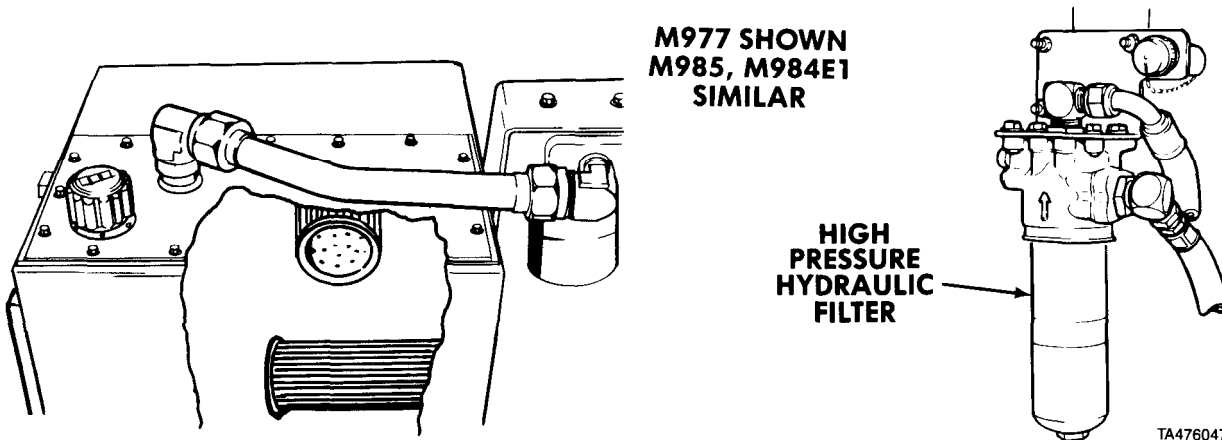
Malfunction

Test or Inspection

Corrective Action

MATERIAL HANDLING CRANE (M977, M985, M984E1) (CONT)

9. CRANE CONTROLS STICKING.



Step 1. Check high pressure hydraulic filter for contamination.

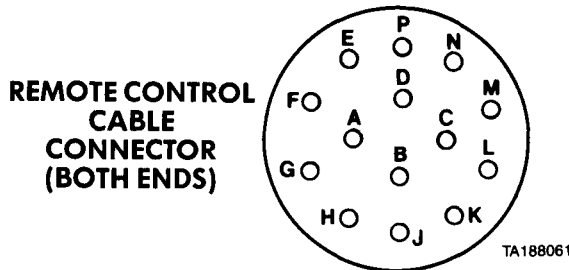
If contamination is found, determine cause of contamination. Drain reservoir, replace strainers (para 13-11) (M984E1: para 13-15), change high pressure filter (para 19-17) and return line filter (para 13-8) (M984E1: para 13-13). Fill with oil (LO 9-2320-279-12), then purge system by operating crane (TM 9-2320-279-10).

Step 2. If problem remains, notify the supervisor.

10. REMOTE CONTROLLER WILL NOT OPERATE CRANE OR OPERATES ABNORMALLY.

Step 1. Make a visual check of remote controller cable for loose connectors.

Tighten loose connectors. Replace remote controller cable if there are more than two broken wires.



Step 2. Check each wire in remote controller cable for zero ohms between both ends of cable.

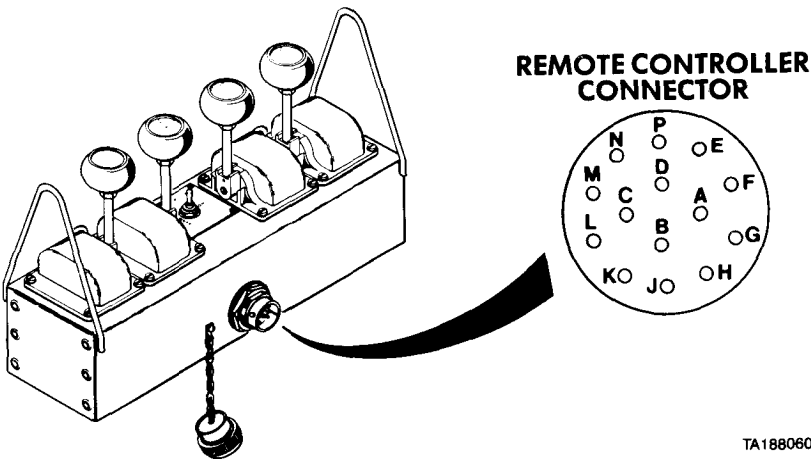
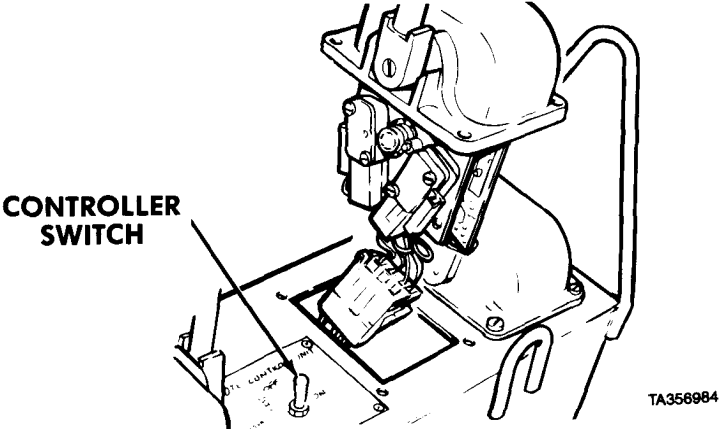
If meter does not show zero ohms in any wire, repair defective wire.

If more than two wires are defective, repair remote controller cable (para 17-23.1).

Troubleshooting Malfunctions (Cont)

2-15. TROUBLESHOOTING INSTRUCTIONS (CONT).

Table 2-9. Troubleshooting (Cont)

| Malfunction | Test or Inspection | Corrective Action | | | | | | | | | | | | | | | | | | | | | | |
|--|---|---|-----|---------|---|-----------|---|----------|---|---------|---|----------|---|-----------|---|---------|---|------------|---|----------|---|---------------|---|----------------|
| MATERIAL HANDLING CRANE (M977, M985, M984E1) (CONT) | | | | | | | | | | | | | | | | | | | | | | | | |
| 10. REMOTE CONTROLLER WILL NOT OPERATE CRANE OR OPERATES ABNORMALLY (CONT). |  | <table border="0"> <thead> <tr> <th data-bbox="1105 644 1160 672">PIN</th> <th data-bbox="1228 644 1367 672">CONTROL</th> </tr> </thead> <tbody> <tr> <td data-bbox="1122 708 1139 736">A</td> <td data-bbox="1228 708 1384 736">SWING CCW</td> </tr> <tr> <td data-bbox="1122 757 1139 785">B</td> <td data-bbox="1228 757 1367 785">SWING CW</td> </tr> <tr> <td data-bbox="1122 806 1139 834">D</td> <td data-bbox="1228 806 1337 834">TELE IN</td> </tr> <tr> <td data-bbox="1122 855 1139 883">C</td> <td data-bbox="1228 855 1367 883">TELE OUT</td> </tr> <tr> <td data-bbox="1122 904 1139 932">M</td> <td data-bbox="1228 904 1401 932">BOOM DOWN</td> </tr> <tr> <td data-bbox="1122 953 1139 981">N</td> <td data-bbox="1228 953 1354 981">BOOM UP</td> </tr> <tr> <td data-bbox="1122 1002 1139 1029">G</td> <td data-bbox="1228 1002 1401 1029">HOIST DOWN</td> </tr> <tr> <td data-bbox="1122 1051 1139 1078">F</td> <td data-bbox="1228 1051 1354 1078">HOIST UP</td> </tr> <tr> <td data-bbox="1122 1100 1139 1127">H</td> <td data-bbox="1228 1100 1454 1127">VEHICLE POWER</td> </tr> <tr> <td data-bbox="1122 1149 1139 1176">L</td> <td data-bbox="1228 1149 1471 1176">VEHICLE GROUND</td> </tr> </tbody> </table> | PIN | CONTROL | A | SWING CCW | B | SWING CW | D | TELE IN | C | TELE OUT | M | BOOM DOWN | N | BOOM UP | G | HOIST DOWN | F | HOIST UP | H | VEHICLE POWER | L | VEHICLE GROUND |
| PIN | CONTROL | | | | | | | | | | | | | | | | | | | | | | | |
| A | SWING CCW | | | | | | | | | | | | | | | | | | | | | | | |
| B | SWING CW | | | | | | | | | | | | | | | | | | | | | | | |
| D | TELE IN | | | | | | | | | | | | | | | | | | | | | | | |
| C | TELE OUT | | | | | | | | | | | | | | | | | | | | | | | |
| M | BOOM DOWN | | | | | | | | | | | | | | | | | | | | | | | |
| N | BOOM UP | | | | | | | | | | | | | | | | | | | | | | | |
| G | HOIST DOWN | | | | | | | | | | | | | | | | | | | | | | | |
| F | HOIST UP | | | | | | | | | | | | | | | | | | | | | | | |
| H | VEHICLE POWER | | | | | | | | | | | | | | | | | | | | | | | |
| L | VEHICLE GROUND | | | | | | | | | | | | | | | | | | | | | | | |
| <p>Step 3. Check for defective remote controller. Set multimeter to X1K. Set remote controller switch to ON and place negative (-) probe on pins as shown, with positive (+) probe always on pin H. As each crane function control is operated, meter should show zero to 15 ohms.</p> | | | | | | | | | | | | | | | | | | | | | | | | |
| <p>If meter does not show zero to 15 ohms in all control functions, replace defective remote controller assembly on/off switch (para 17-23).</p> | | | | | | | | | | | | | | | | | | | | | | | | |
|  | | | | | | | | | | | | | | | | | | | | | | | | |

Troubleshooting Malfunctions (Cont)
 Table 2-9. Troubleshooting (Cont)

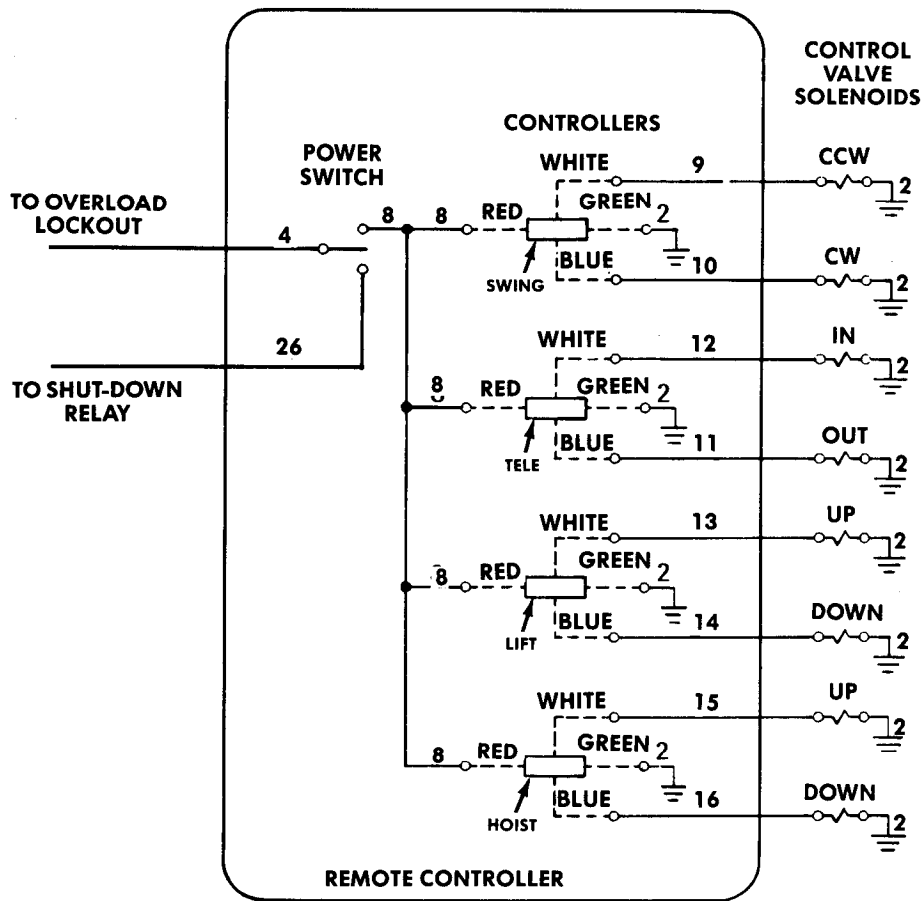
| Malfunction | Test or Inspection | Corrective Action |
|-------------|--------------------|-------------------|
|-------------|--------------------|-------------------|

MATERIAL HANDLING CRANE (M977, M985, M984E1) (CONT)

10. REMOTE CONTROLLER WILL NOT OPERATE CRANE OR OPERATES ABNORMALLY (CONT).

If meter shows infinite ohms in one control function, check for broken wires in controller (para 17-23). Repair broken wires (figs. 2-9 and 2-10).

If problem remains, replace defective controller (para 17-23).



LEGEND

- STANDARD WIRING
- - - - - EXISTING WIRING
- CONNECTED WIRES

TA188062

Figure 2-9. Remote Controller Electrical Schematic (M977, M985, M984E1).

Troubleshooting Malfunctions (Cont)

2-15. TROUBLESHOOTING INSTRUCTIONS (CONT).

Table 2-9. Troubleshooting (Cont)

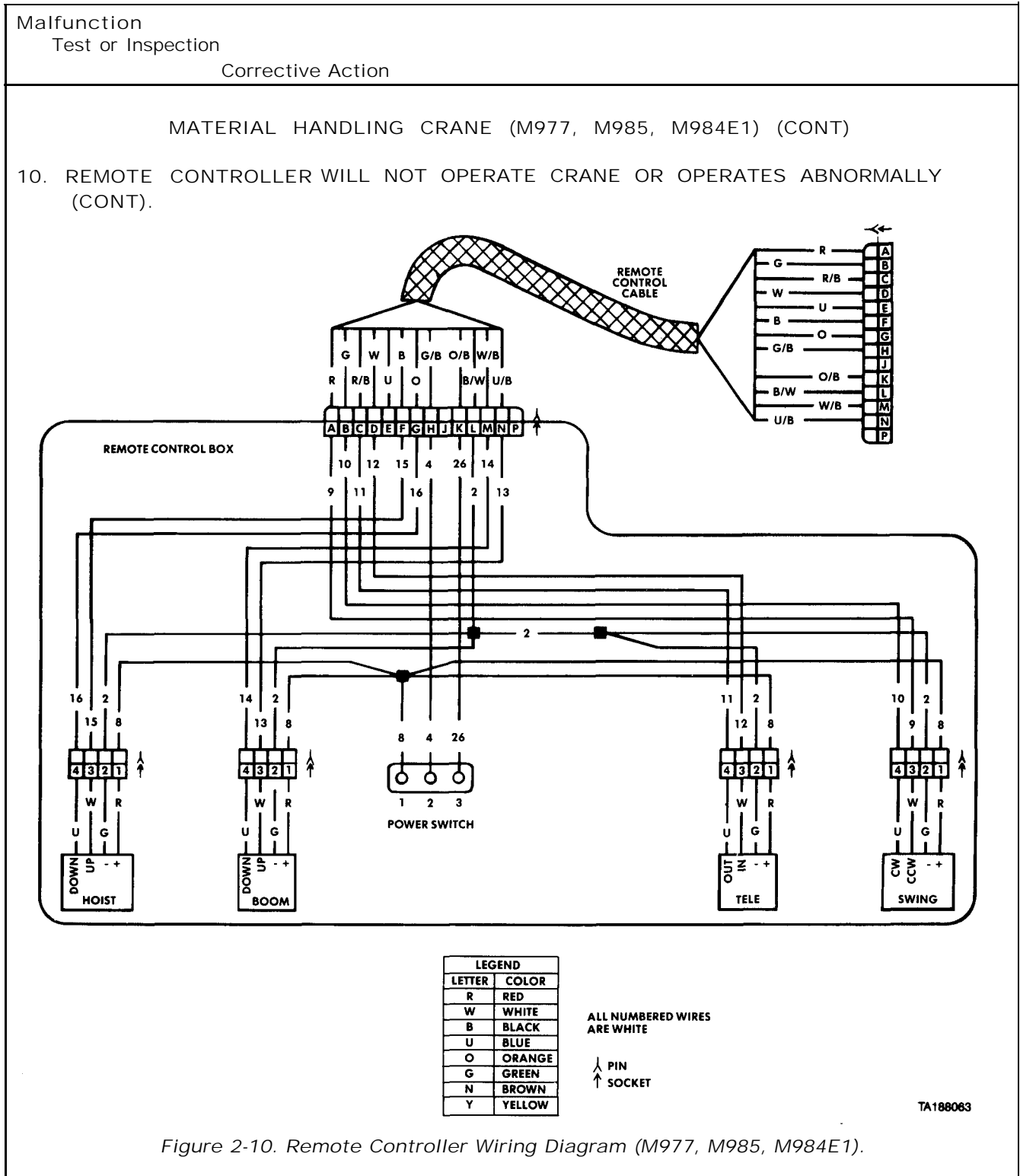


Figure 2-10. Remote Controller Wiring Diagram (M977, M985, M984E1).

Troubleshooting Malfunctions (Cont)
 Table 2-9. Troubleshooting (Cont)

| Malfunction | Test or Inspection | Corrective Action |
|---------------------------|---|--|
| RETRIEVER SYSTEM (M984E1) | | |
| 1. | RETRIEVER SYSTEM WILL NOT OPERATE, WILL NOT LIFT LOAD, WILL NOT LOWER LOAD OR WILL NOT CENTER TOW CYLINDERS (M984E1). | <p>Step 1. Check hydraulic lines for loose or damaged fittings. Tighten loose fittings. Replace damaged fittings. Add oil as required (TM 9-2320-279-12).</p> <p>Step 2. Check if crane operates (TM 9-2320-279-10). If crane does not operate, go to MATERIAL HANDLING CRANE Troubleshooting. If problem is not solved, notify the supervisor.</p> |

Troubleshooting Malfunctions (Cont)
 Table 2-9. Troubleshooting (Cont)

| Malfunction | Test or Inspection | Corrective Action |
|-------------|--------------------|-------------------|
|-------------|--------------------|-------------------|

TANKER SYSTEM

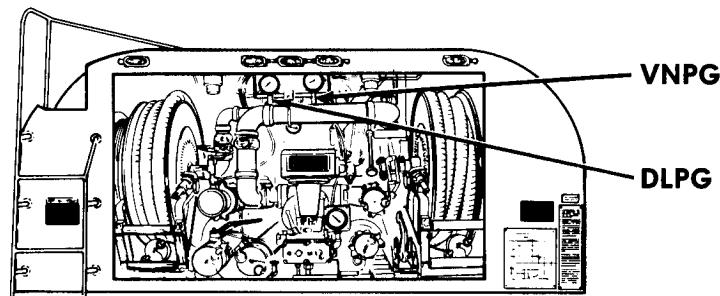
WARNING

Before starting any troubleshooting on the M978 tanker, be sure to read and follow all safety precautions in FM 10-71, Petroleum Tank Vehicle Operations, and TM 9-2320-279-10, Operate tanker. Liquids and vapors carried in the M978 tanker are flammable and toxic and can cause injury or death.

NOTE

When troubleshooting the M978 tanker, refer to Figure 2-11, Tanker Component Identification, Figure 2-12, Tanker Fuel System Functional Diagram, Figure 2-13, Tanker Operation Functional Diagram, and Figure 2-14, Tanker Fuel System Schematic and FO-1, Electric Diagram.

1. DISCHARGE LINE PRESSURE GAGE (DLPG) OR VENTURI NOZZLE PRESSURE GAGE (VNPG) NOT WORKING.



TA187387

Step 1. Check DLPG/VNPG gage tubing connections for looseness or damage and for damaged tubing.

Tighten loose tubing or damaged connections and replace damaged tubing.

Step 2. Check for obstructions in DLPG/VNPG tubing and in piping at tubing connections.

Remove tubing from DLPG/VNPG gages and piping (para 25-4). Clean piping and tubing. Inspect for damage. Replace damaged tubing.

Step 3. If problem remains, replace defective DLPG/VNPG gage (para 22-3 or 22-4).

Troubleshooting Malfunctions (Cont)

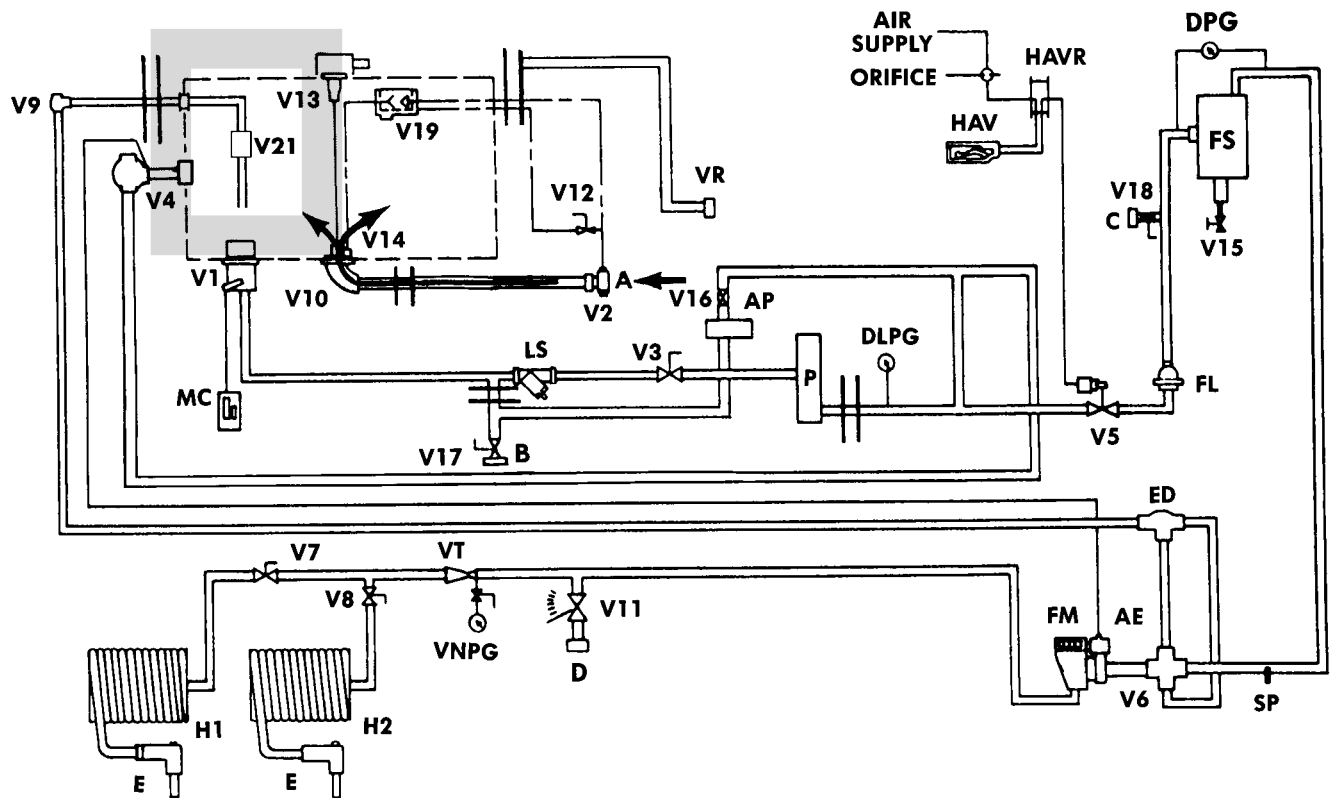
Table 2-9. Troubleshooting (Cont)

| Designator | Description | Designator | Description |
|------------|---------------------------------------|------------|----------------------------------|
| A | Bottom Load Adapter (inlet) | TC | Throttle Control Switch |
| AE | Air Eliminator | TLI | Tank Level Indicator Switch |
| AP | Auxiliary Pump | VNPG | Venturi/Nozzle Pressure Gage |
| APC | Auxiliary Pump Control Switch | VR | Vapor Recovery Connection |
| B | Gravity Discharge (outlet) | VT | Venturi |
| C | Unfiltered 300 GPM (outlet) | V1 | Emergency Valve |
| D | Bulk Unload Regulated (outlet) | V2 | Bottom Load Adapter |
| DPG | Differential Pressure Gage | V3 | Suction Line Valve |
| DLPG | Discharge Line Pressure Gage | V4 | Bypass Valve |
| E | (2) Fueling Connection | V5 | Flow Valve Air Actuated |
| ED | Eductor | V6 | Fuel/Defuel Valve |
| FL | Flow Limiting Valve 300 GPM | V7 | Reel Valve (H1) |
| FM | Flowmeter | V8 | Reel Valve (H2) |
| FS | Filter-Separator | V9 | Check Valve |
| H1 | Reel 1.5 x 50 | V10 | Bottom Load Valve |
| H1C | Hose Reel Crank Connection | V11 | Flow Regulator Valve 10 Position |
| H2 | Reel 1.5 x 50 | V12 | Bottom Load Precheck Valve |
| H2C | Hose Reel Crank Connection | V13 | Vent Valve |
| HAV | Hand Actuated Control Valve (Deadman) | V14 | Pilot Valve |
| HAVR | Reel Spring Return 50 ft. Twin | V15 | Drain Valve |
| LS | Line Strainer | V16 | Auxiliary Pump Check Valve |
| MC | Manual Em. Valve Control | V17 | Gravity Discharge Valve |
| P | Primary Pump | V18 | Bulk Del. Valve |
| SP | Sampling Probe | V19 | Jet Level Sensor Valve |
| SR1 | Static Reel | V21 | Check Valve |
| SR2 | Static Reel | V22 | Check Valve |

Figure 2-11. Tanker Component Identification.

Troubleshooting Malfunctions (Cont)

Table 2-9. Troubleshooting (Cont)



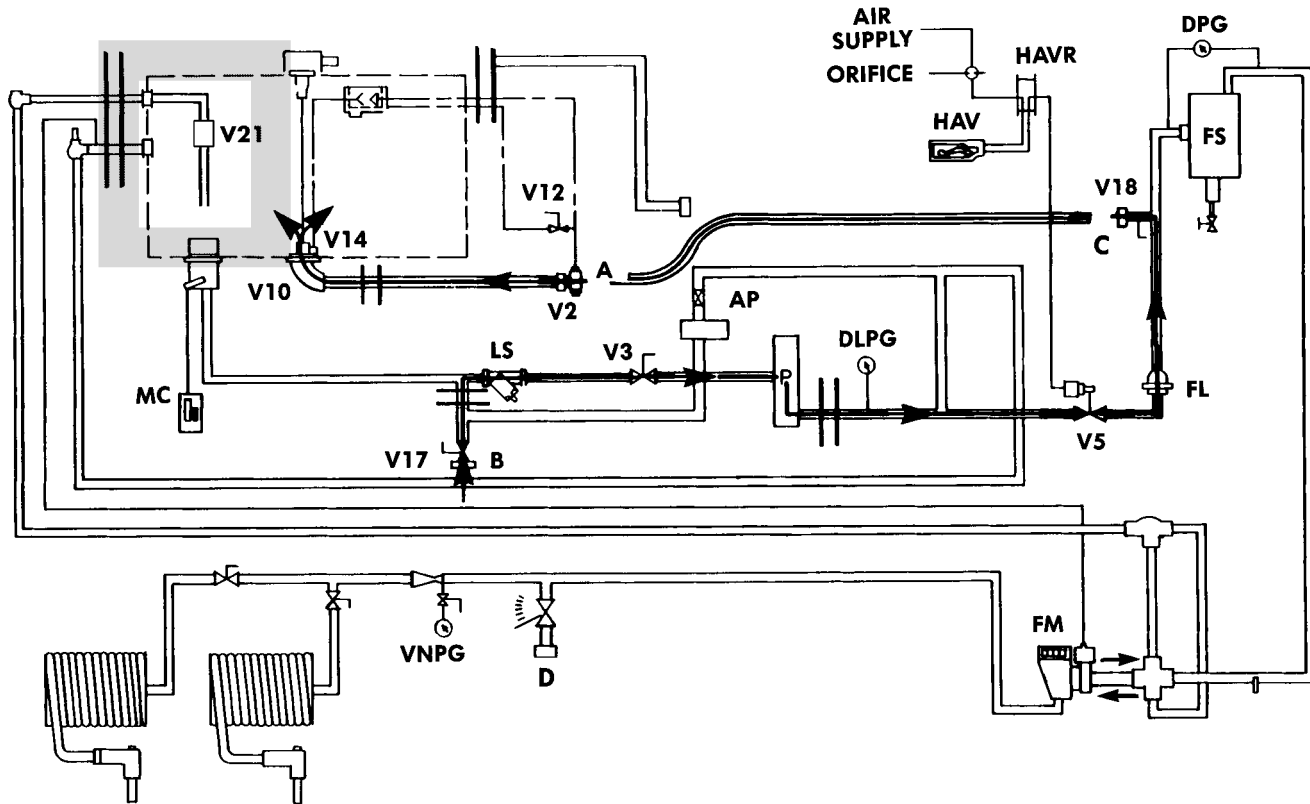
NOTE

Refer to Figure 2-11 for tanker component identification.

Figure 2-12. Tanker Fuel System Functional Diagram.

Troubleshooting Malfunctions (Cont)

Table 2-9. Troubleshooting (Cont)



BOTTOM LOAD (SELF-CONTAINED PUMP 300 GPM)

In the operation above, fuel is being pumped from an external reservoir into the tanker by means of the tanker's own fuel pump, capable of pumping 300 GPM. Here the fuel is drawn into the module via the suction hose connected to receptacle B. It then flows to and through the pump (located under the tank between the vehicle frame rails) through valve V5 located in the module and out of receptacle C. The fuel then flows through the discharge hose into receptacle A. From this point the operation is the same as described earlier. The HAV valve referred to is operated by the vehicle air system. The HAV is used in all operations where the fuel pump is used and serves as a safety shut off in case of emergency. When pumping is described the HAV is engaged which opens valve V5 allowing fuel to flow into the module.

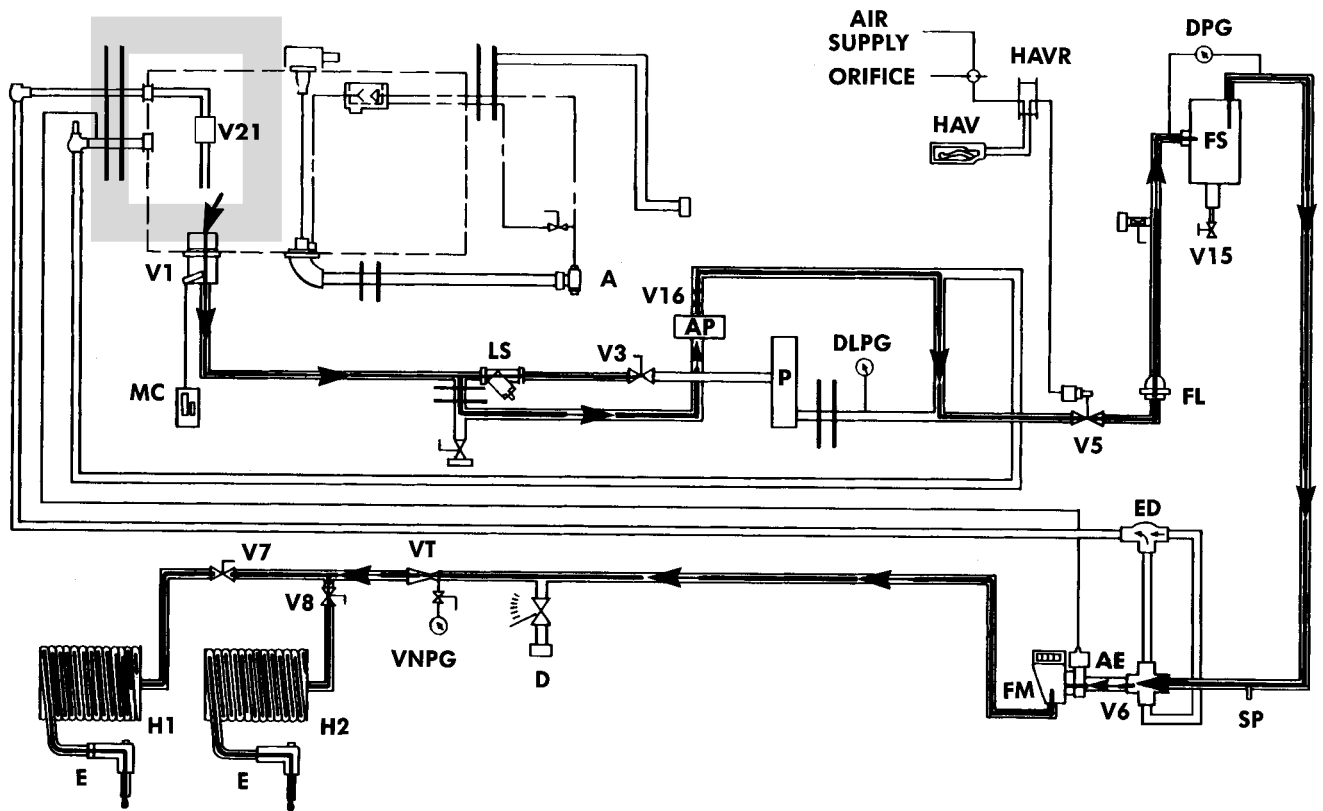
NOTE

Refer to Figure 2-11 for tanker component identification.

Figure 2-13. Tanker Operation Functional Diagram (Sheet 1 of 12).

Troubleshooting Malfunctions (Cont)

Table 2-9. Troubleshooting (Cont)



AUXILIARY PUMP OPERATION

This is the same as the basic pumping operation except the 24 volt driven auxiliary pump is used in place of the PTO driven pump. Valve V3 must be closed to prevent recirculation or fuel will not flow from the nozzle.

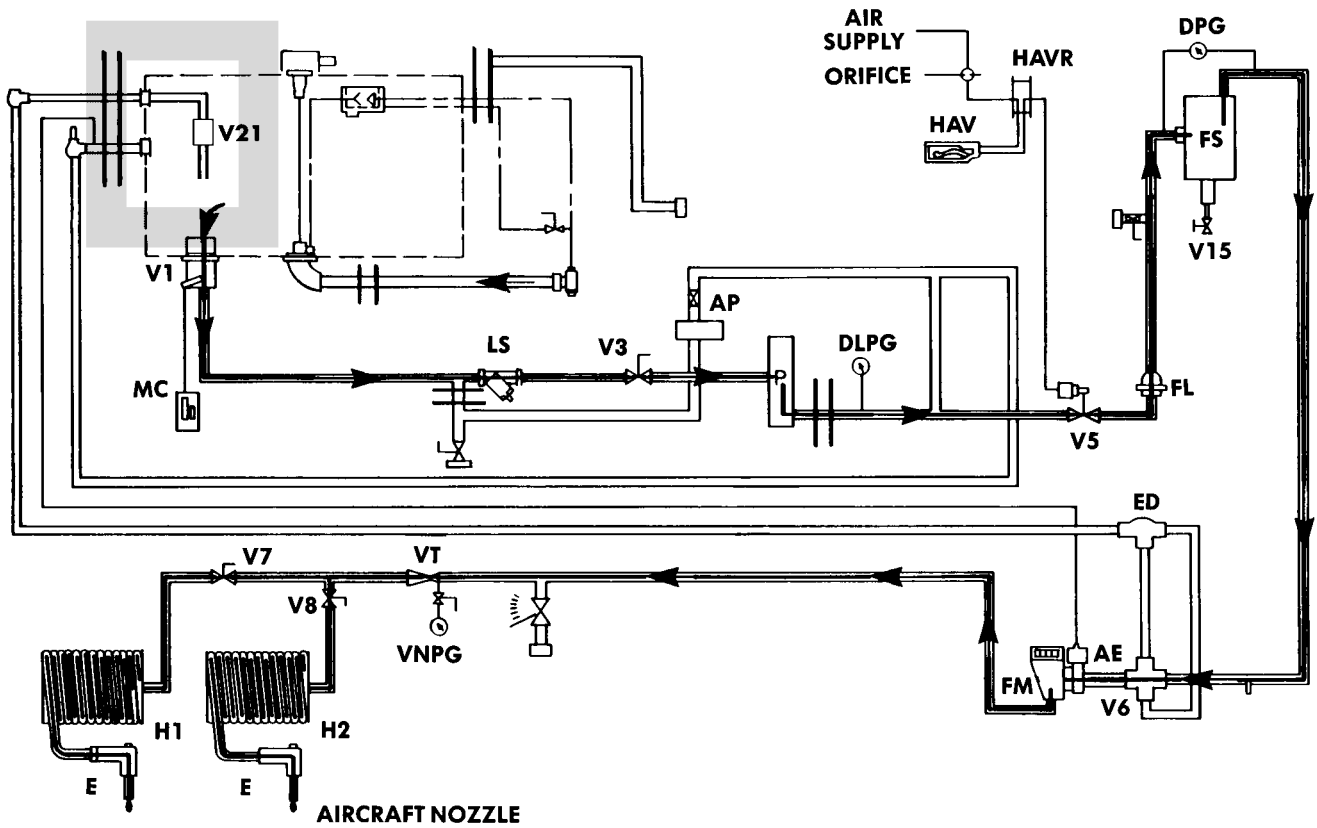
NOTE

Refer to Figure 2-11 for tanker component identification.

Figure 2-13. Tanker Operation Functional Diagram (Sheet 2 of 12).

Troubleshooting Malfunctions (Cont)

Table 2-9. Troubleshooting (Cont)



FUEL SERVICING (AUTOMATIC FILTERED)

Flow leaves the tank through valve V1 and flows to the pump. From there it goes through valve V5 and to the FS (filter-separator). It then goes to valve V6 where it is routed through the flowmeter and on to either V7 or V8 depending on which hose reel is selected for use.

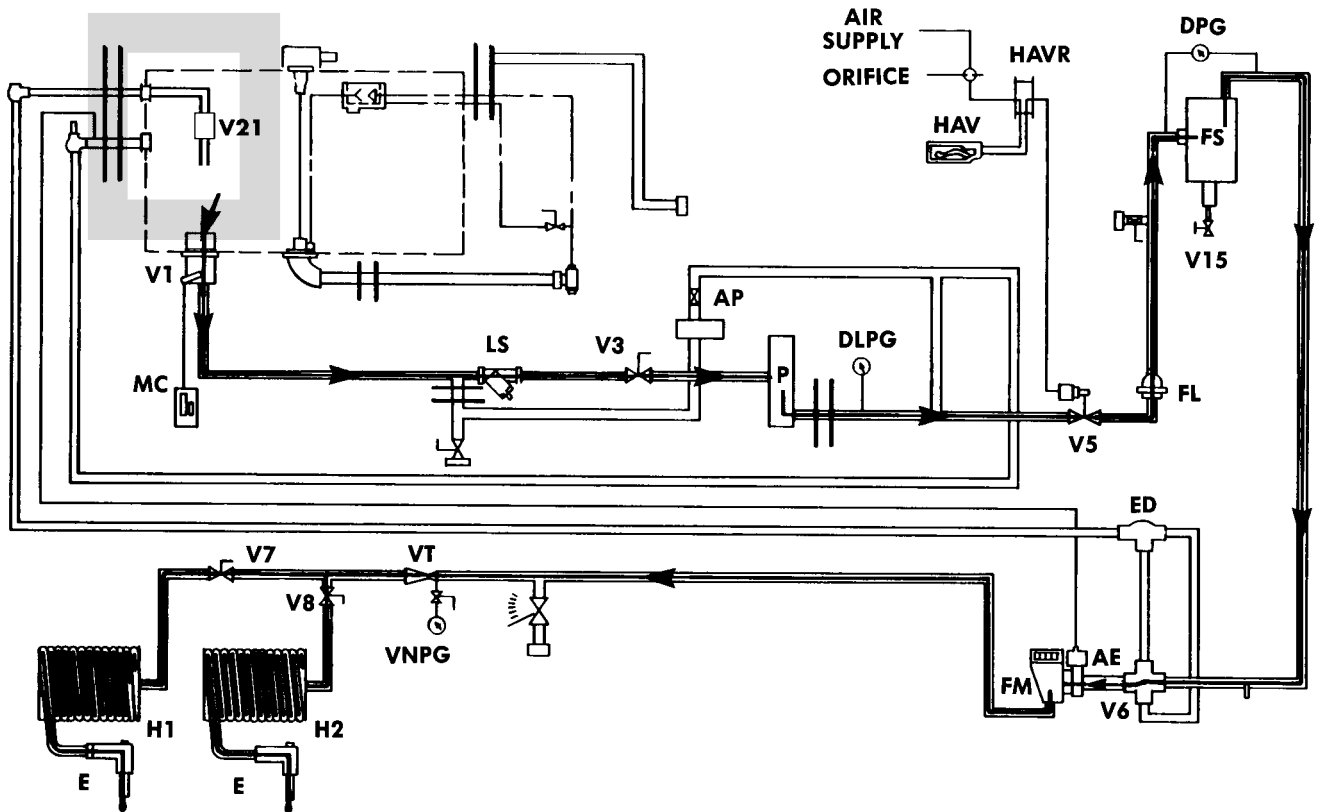
NOTE

Refer to Figure 2-11 for tanker component identification.

Figure 2-13. Tanker Operation Functional Diagram (Sheet 3 of 12).

Troubleshooting Malfunctions (Cont)

Table 2-9. Troubleshooting (Cont)



FUEL SERVICING (OVER WING)

This operation is the same as the previous except an aircraft type fuel nozzle is attached to the end of the hose reels.

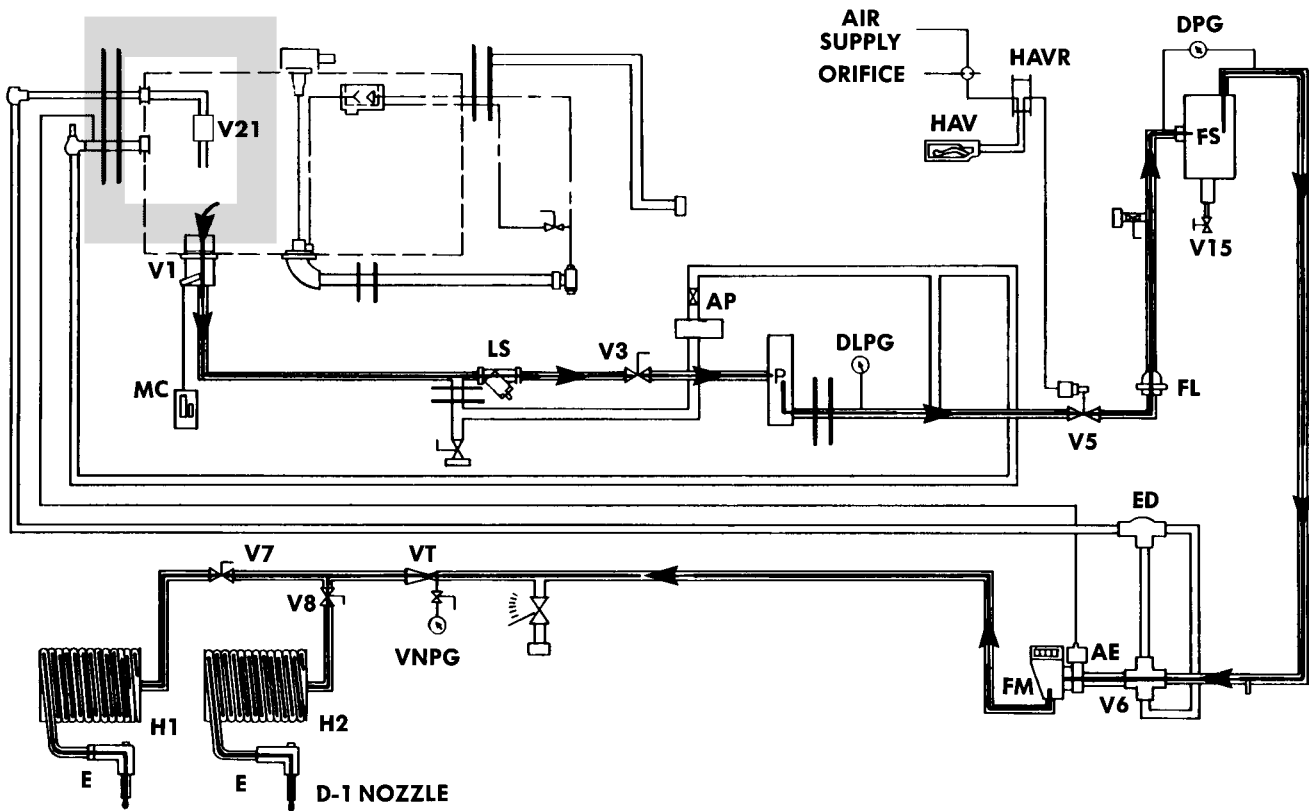
NOTE

Refer to Figure 2-11 for tanker component identification.

Figure 2-13. Tanker Operation Functional Diagram (Sheet 4 of 12).

Troubleshooting Malfunctions (Cont)

Table 2-9. Troubleshooting (Cont)



FUEL SERVICING (CLOSED CIRCUIT & D-1 NOZZLE)

This operation is the same as previously described except a D1 type fuel nozzle is used.

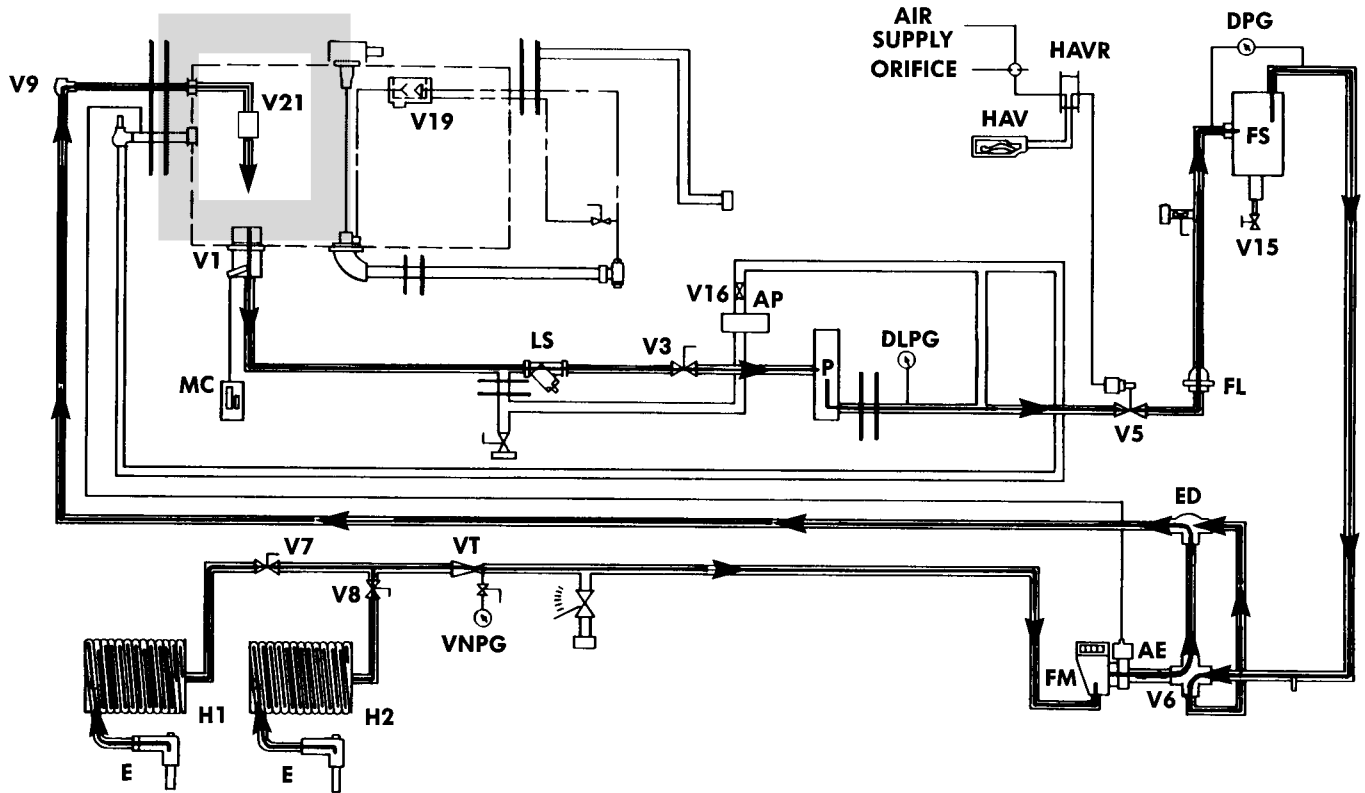
NOTE

Refer to Figure 2-11 for tanker component identification.

Figure 2-13. Tanker Operation Functional Diagram (Sheet 5 of 12).

Troubleshooting Malfunctions (Cont)

Table 2-9. Troubleshooting (Cont)



EVACUATE HOSES

The purpose of this operation is to remove the unused fuel from the hose reels. To do this the basic pumping operation is used except the V6 (Fuel/Defuel Valve) is put in the defuel position. This routes fuel flow to the ED (Eductor) instead of through the flowmeter. Flow through the ED (Eductor) draws the fuel from the hose reels and then both flow back to the tank through valve V9 (Check Valve) and valve V21 (model B only).

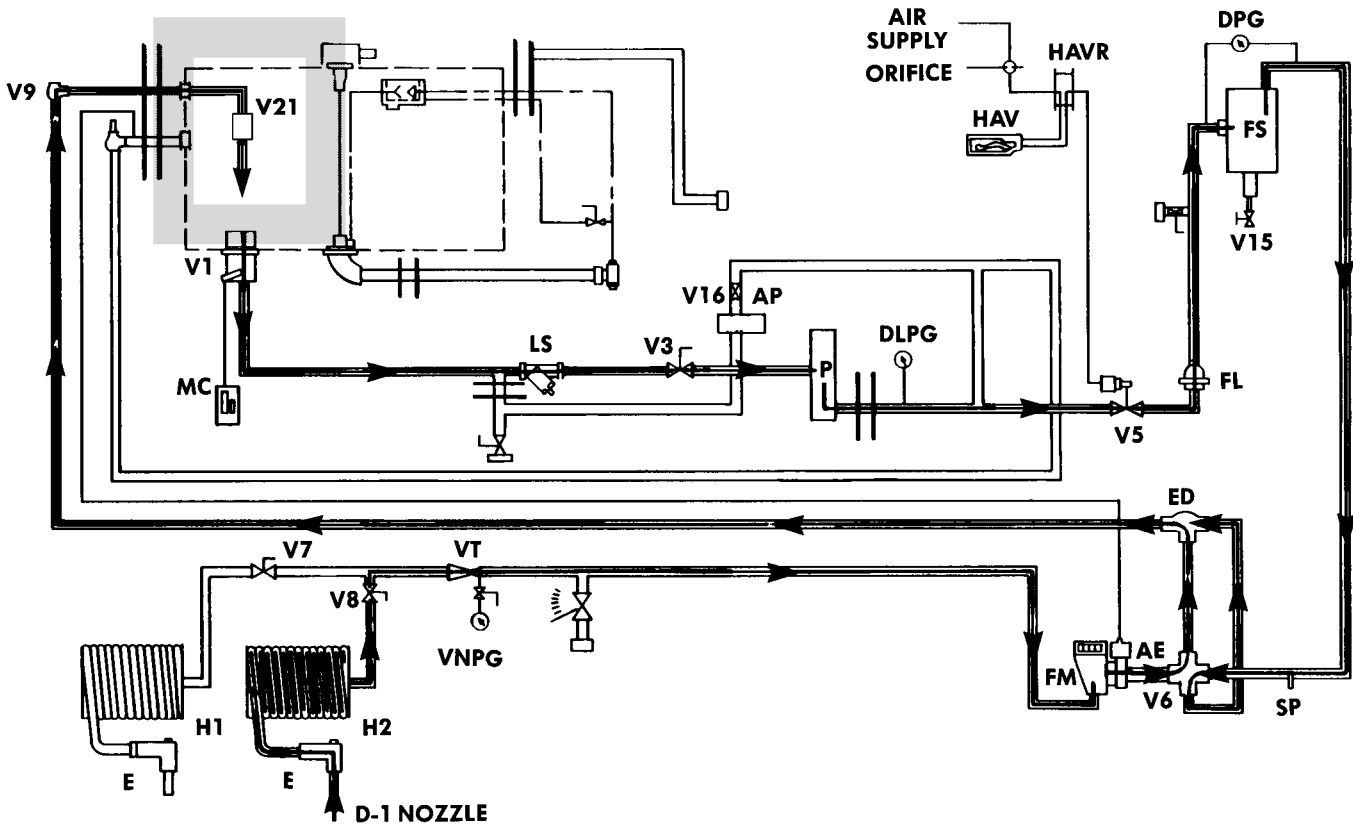
NOTE

Refer to Figure 2-11 for tanker component identification.

Figure 2-13. Tanker Operation Functional Diagram (Sheet 6 of 12).

Troubleshooting Malfunctions (Cont)

Table 2-9. Troubleshooting (Cont)



AIRCRAFT DEFUEL

This operation is the same as used to evacuate the hose reels except only one hose reel is used with the D-1 nozzle and is attached to the aircraft fuel tank.

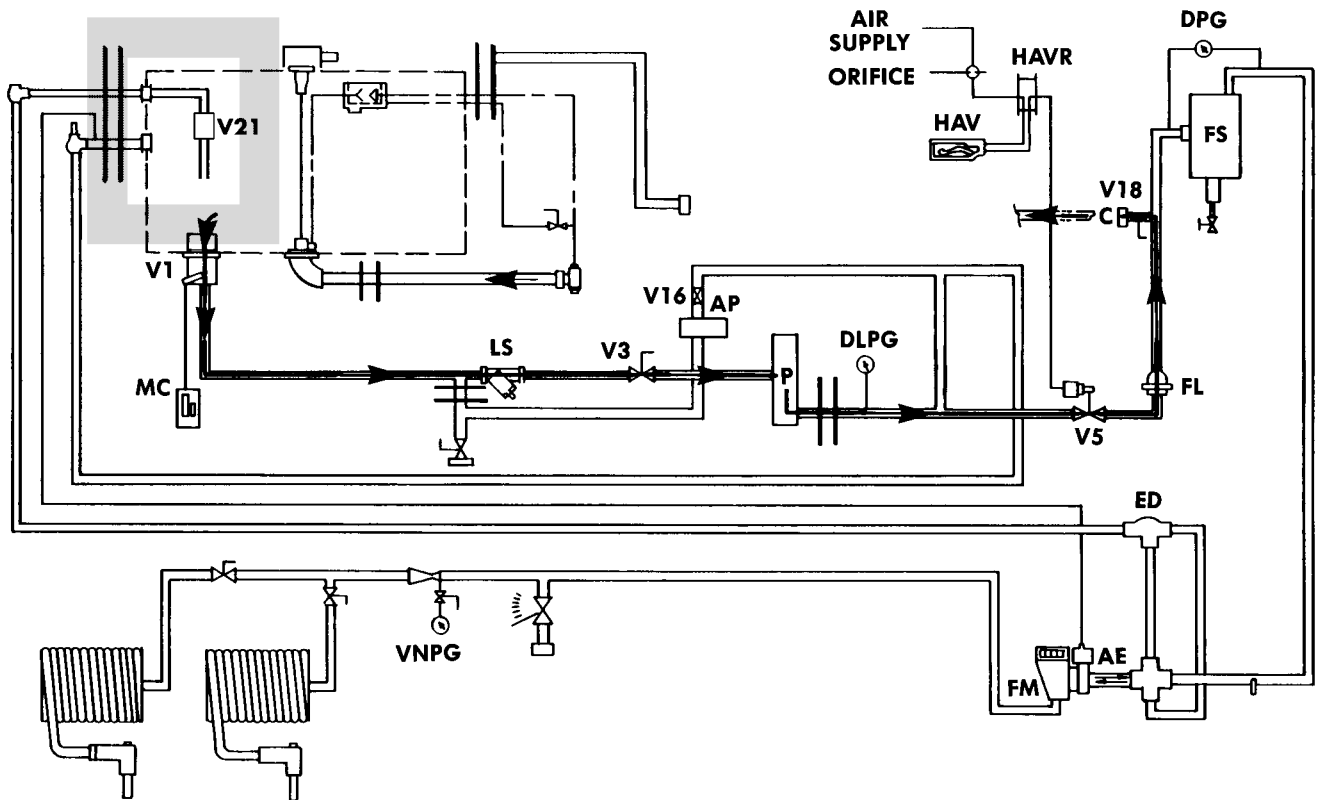
NOTE

Refer to Figure 2-11 for tanker component identification.

Figure 2-13. Tanker Operation Functional Diagram (Sheet 7 of 12).

Troubleshooting Malfunctions (Cont)

Table 2-9. Troubleshooting (Cont)



BULK UNLOAD (UNFILTERED)

In this operation, the fuel in the tanker is being pumped out by the vehicle's own pump. The fuel leaves the tank by the Emergency Valve (V1) and flows to the pump. It goes through V5 and then to V18 where it leaves by receptacle C through an externally attached hose.

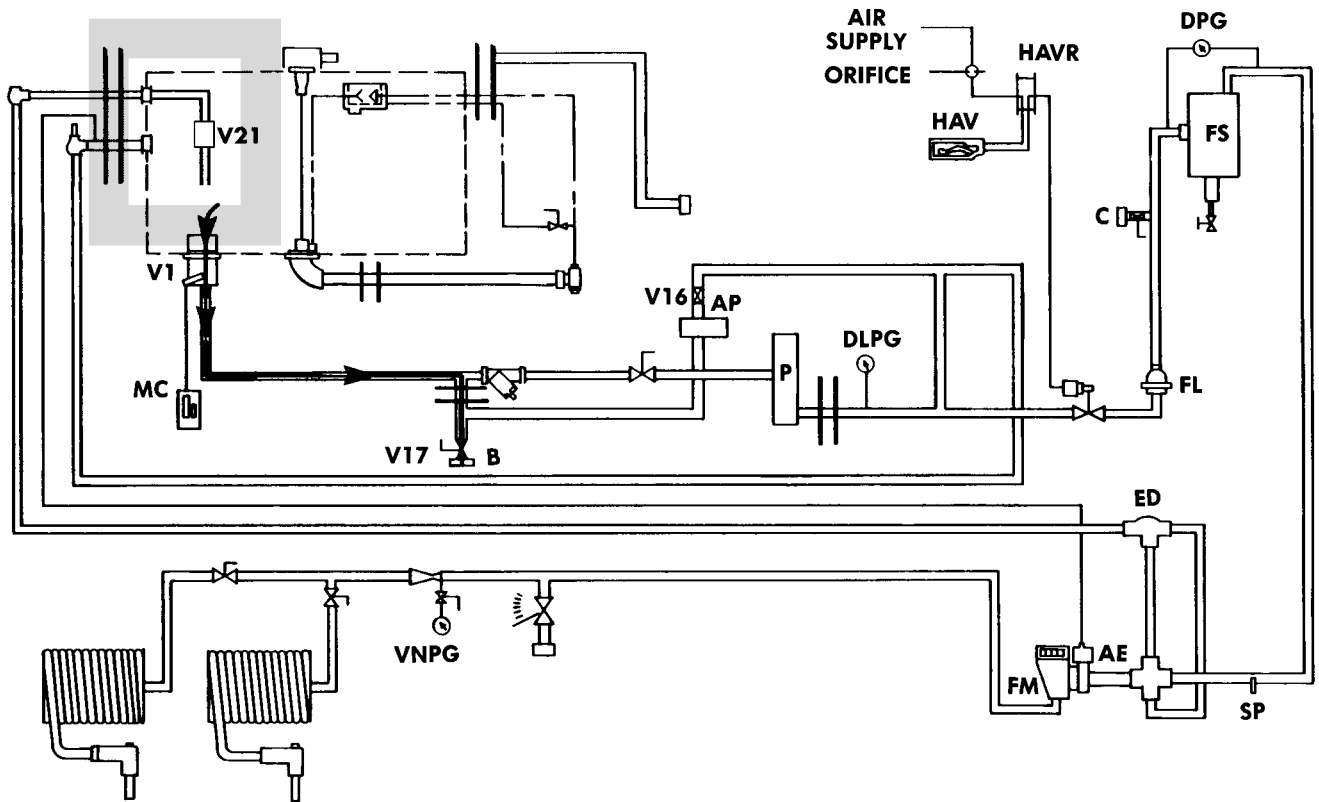
NOTE

Refer to Figure 2-11 for tanker component identification.

Figure 2-13. Tanker Operation Functional Diagram (Sheet 10 of 12).

Troubleshooting Malfunctions (Cont)

Table 2-9. Troubleshooting (Cont)



GRAVITY (UNFILTERED)

In this operation, gravity acts to transfer fuel from the tanker to some external reservoir which must be at a lower level than the tanker. Fuel leaves valve V1 and flows to valve V17 and leaves out of receptacle B by an externally connected hose.

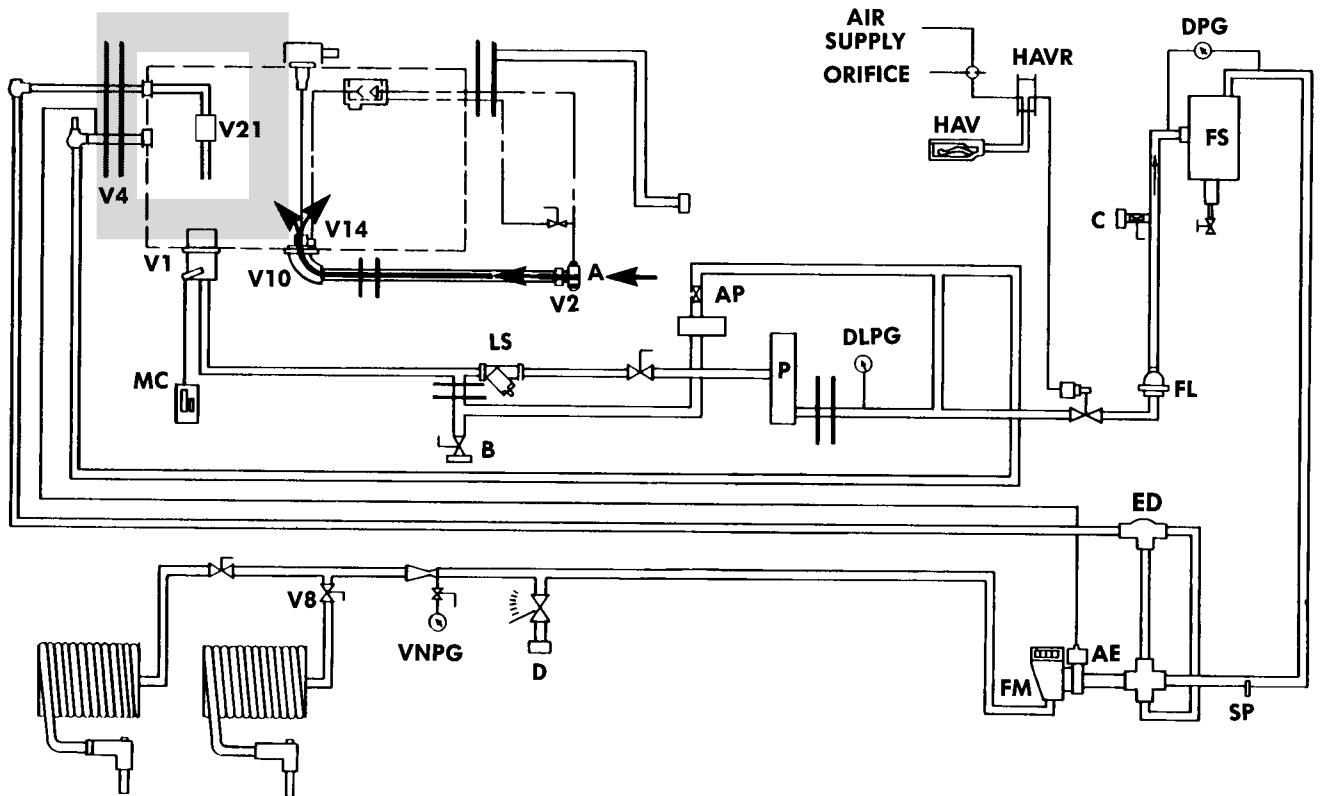
NOTE

Refer to Figure 2-11 for tanker component identification.

Figure 2-13. Tanker Operation Functional Diagram (Sheet 11 of 12).

Troubleshooting Malfunctions (Cont)

Table 2-9. Troubleshooting (Cont)



BOTTOM LOAD (EXTERIOR PUMP - 600 GPM)

In the operation above, the tanker is filled from a reservoir which has its own pump able to transfer fuel at rates up to 600 GPM. Receptacle A feeds directly into the tanker. The fuel can only flow through receptacle A when valve V10 is open. Valve V10 opens as soon as the fuel pressure is available at receptacle A unless the level of the fuel in the tank is at its maximum level. This serves as an automatic shut-off so that when the fuel level rises to the full level valve V10 closes preventing the tank from being over-filled.

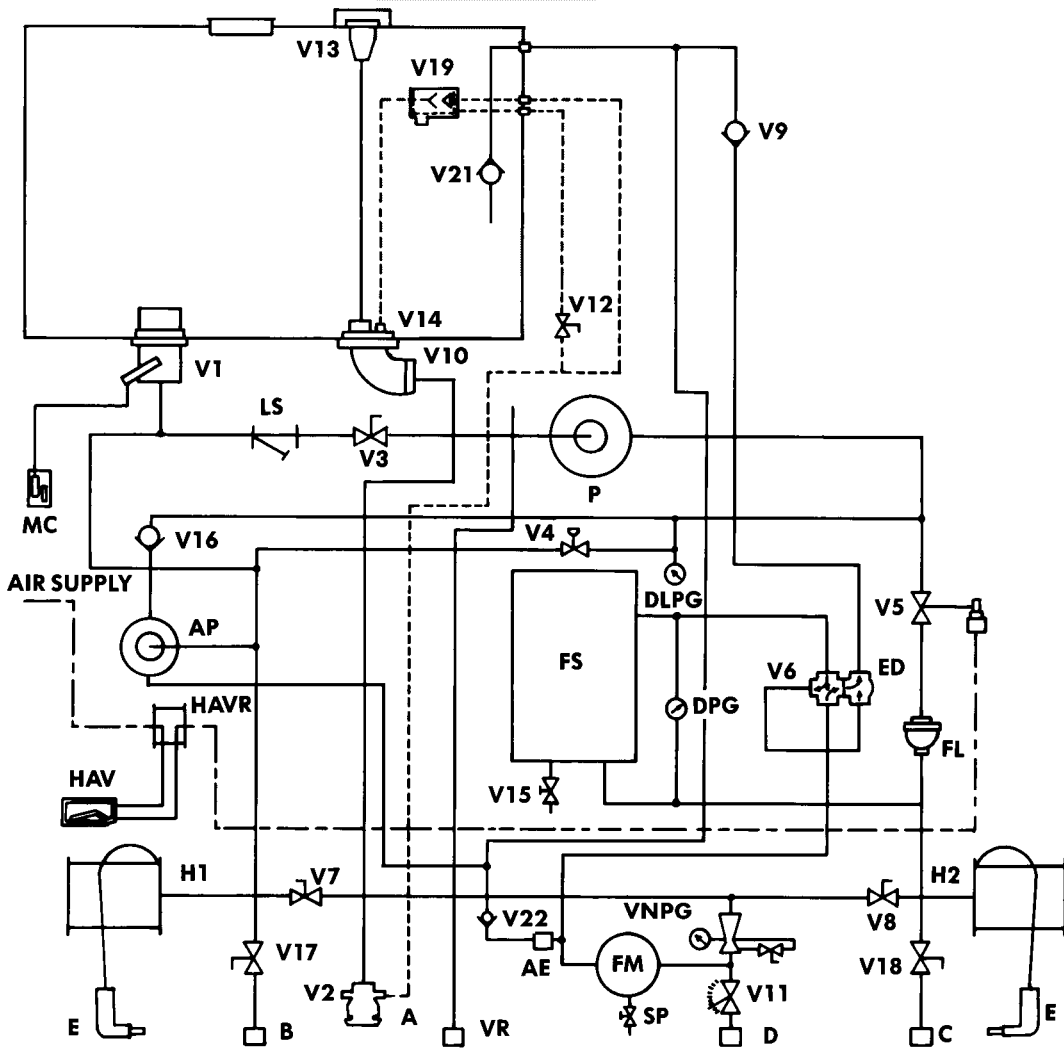
NOTE

Refer to Figure 2-11 for tanker component identification.

Figure 2-13. Tanker Operation Functional Diagram (Sheet 12 of 12).

Troubleshooting Malfunctions (Cont)

Table 2-9. Troubleshooting (Cont)



NOTE

Refer to Figure 2-11 for tanker component identification.

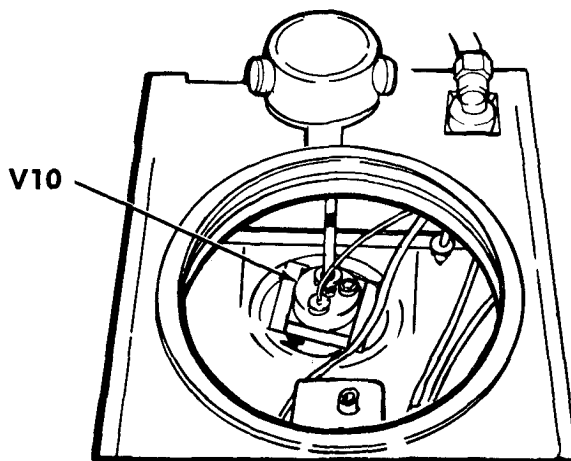
Figure 2-14. Tanker Fuel System Schematic.

Troubleshooting Malfunctions (Cont)
Table 2-9. Troubleshooting (Cont)

Malfunction
Test or Inspection
Corrective Action

TANKER SYSTEM (CONT)

2. FUEL SPILLS FROM VENT WHEN BOTTOM LOADING WITH EXTERIOR PUMP.



TA187402

Step 1. Remove V10 bottom load valve (para 25-24). Check for damage, dirt, and debris.
Remove dirt and debris. Replace damaged V10 bottom load valve.

Troubleshooting Malfunctions (Cont)

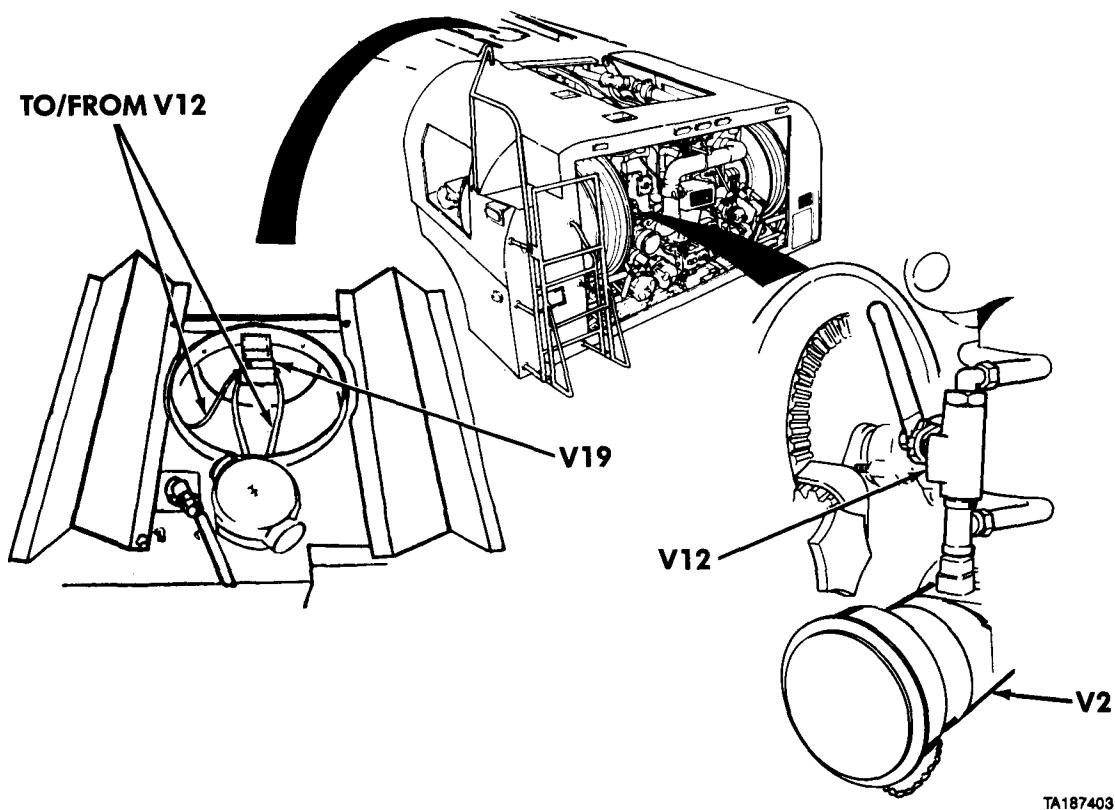
2-15. TROUBLESHOOTING INSTRUCTIONS (CONT).

Table 2-9. Troubleshooting (Cont)

| Malfunction | Test or Inspection | Corrective Action |
|-------------|--------------------|-------------------|
|-------------|--------------------|-------------------|

TANKER SYSTEM (CONT)

3. FUEL FLOW DOES NOT STOP WITHIN 15 SECONDS AFTER OPENING V12 B/L PRECHECK VALVE WHEN BOTTOM LOADING WITH EXTERIOR PUMP.



TA187403

Step 1. Remove V12 bottom load PRECHECK VALVE to V19 jet level sensor valve tubing (paras 25-26 and 25-32). Check for blocked or damaged V12 bottom load PRECHECK VALVE to V19 jet level sensor valve tubing.

Clean blocked tubing. Replace damaged V12 bottom load PRECHECK VALVE to V19 jet level sensor tubing.

Step 2. Remove V12 bottom load PRECHECK VALVE (para 25-26). Check for damaged V12 bottom load PRECHECK VALVE. Check for dirt and debris in V12 bottom load PRECHECK VALVE and in connection to V2 bottom load adapter.

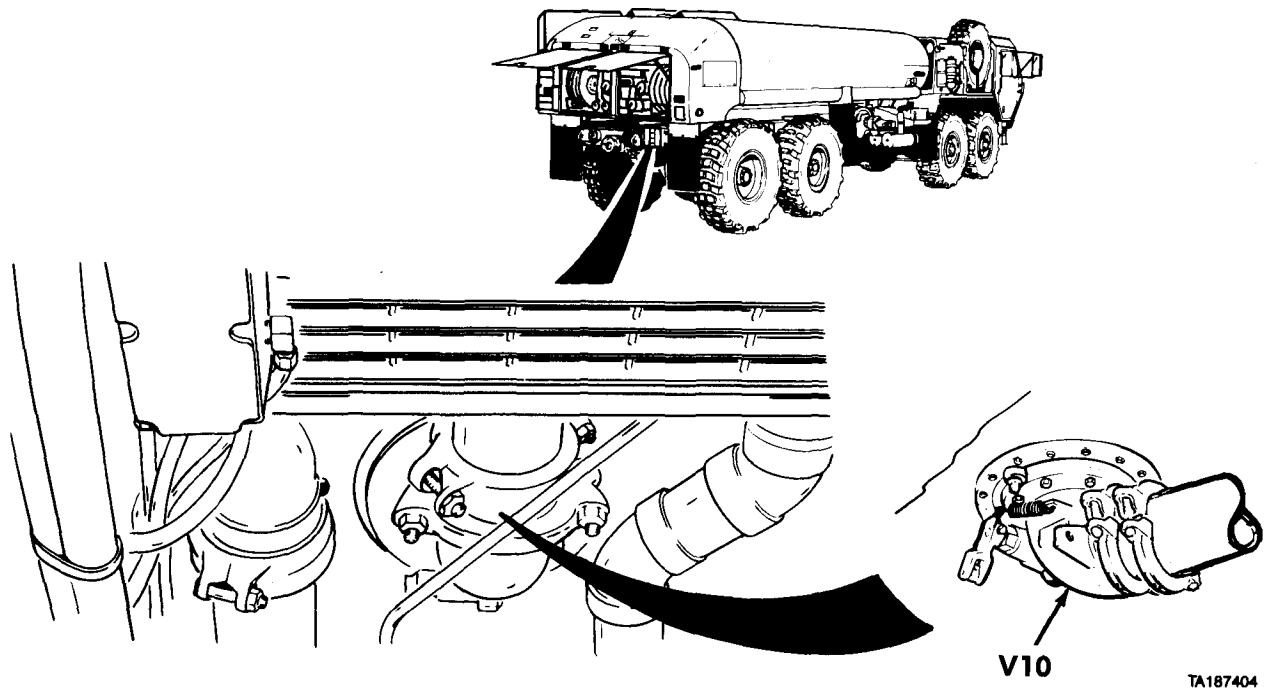
Remove dirt and debris. Replace damaged bottom load V12 PRECHECK VALVE.

Troubleshooting Malfunctions (Cont)
 Table 2-9. Troubleshooting (Cont)

| Malfunction | Test or Inspection | Corrective Action |
|-------------|--------------------|-------------------|
|-------------|--------------------|-------------------|

TANKER SYSTEM (CONT)

- FUEL FLOW DOES NOT STOP WITHIN 15 SECONDS AFTER OPENING V12 B/L PRECHECK VALVE WHEN BOTTOM LOADING WITH EXTERIOR PUMP (CONT).



Step 3. Remove V10 bottom load valve (para 25-24). Check for damage, dirt, and debris.
 Remove dirt and debris. Replace damaged V10 bottom load valve.

Troubleshooting Malfunctions (Cont)

2-15. TROUBLESHOOTING INSTRUCTIONS (CONT.)

Table 2-9. Troubleshooting (Cont)

| Malfunction | Test or Inspection | Corrective Action |
|---|--------------------|-------------------|
| TANKER SYSTEM (CONT) | | |
| 4. CANNOT BOTTOM LOAD FUEL WITH TANKER PUMP. | | |
| | | |
| <p>Step 1. Check for defective air actuator system. Remove air hose from V5 air actuated flow valve. Operate HAV HAND ACTUATED CONTROL VALVE (TM 9-2320-279-10). Check for air blowing out of hose and for continuous exhausting of air from HAV HAND ACTUATED CONTROL VALVE.</p> | | |
| <p style="padding-left: 40px;">If no air, or if HAV HAND ACTUATED CONTROL VALVE continuously exhausts air, repair HAV HAND ACTUATED CONTROL VALVE (para 18-16).</p> | | |
| <p>Step 2. Actuate HAV HAND ACTUATED CONTROL VALVE (TM 9-2320-279-10). Check if V5 air actuated flow valve opens.</p> | | |
| <p style="padding-left: 40px;">Replace defective V5 air actuated flow valve (para 25-19).</p> | | |
| <p>Step 3. Check pressure on DLPG DISCHARGE LINE PRESSURE GAGE while operating pump (TM 9-2320-279-10).</p> | | |
| <p style="padding-left: 40px;">If less than 10 psig (69 kPa) on DLPG DISCHARGE LINE PRESSURE GAGE, replace primary pump (para 25-6).</p> | | |

Troubleshooting Malfunctions (Cont)

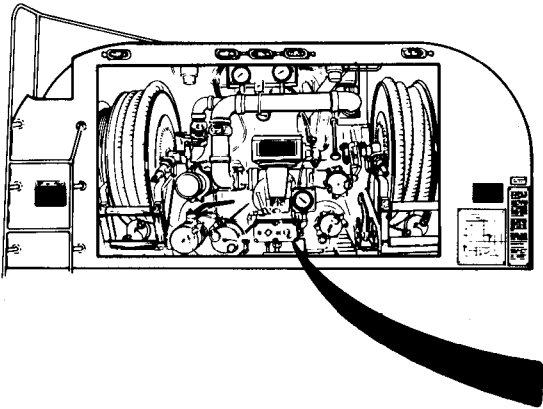
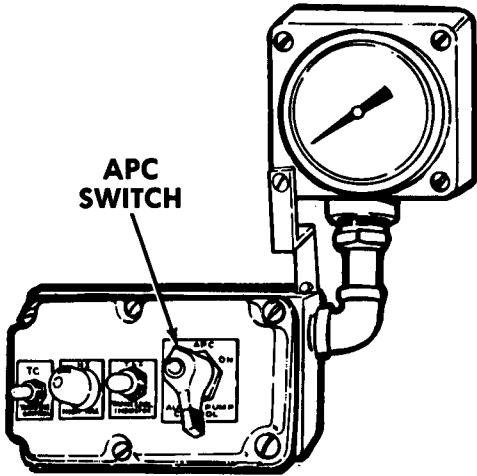
Table 2-9. Troubleshooting (Cont)

| Malfunction | Test or Inspection | Corrective Action |
|---|---|-------------------|
| TANKER SYSTEM (CONT) | | |
| CANNOT BOTTOM LOAD FUEL (CONT). | | |
| | | |
| NOTE | | |
| Steps 4 through 6 apply only when using an external pump. | | |
| Step 4. | Check for loose, damaged, or blocked V14 pilot valve to V19 jet level sensor valve tubing. Tighten loose connections. Clean blocked tubing. Replace damaged tubing (para 25-4). | |
| Step 5. | Remove V19 jet level sensor valve (para 25-32). Check for damage, dirt, and debris. Remove dirt and debris. Replace damaged V19 jet level sensor valve. | |
| Step 6. | Remove V10 bottom load valve and V14 pilot valve (paras 25-24 and 25-28). Check valves for damage, sticking, or binding. Replace defective V10 bottom load and V14 pilot valves. | |

Troubleshooting Malfunctions (Cont)

2-15. TROUBLESHOOTING INSTRUCTIONS (CONT).

Table 2-9. Troubleshooting (Cont)

| Malfunction | Test or Inspection | Corrective Action |
|---|--|---|
| TANKER SYSTEM (CONT) | | |
| 5. AUXILIARY PUMP WILL NOT PUMP FUEL. |  |  |
| TA187407 | | |
| NOTE | | |
| AUXILIARY PUMP is designed for 25 GPM fuel flow. | | |
| <p>Step 1. Check if AUXILIARY PUMP runs when APC AUXILIARY PUMP CONTROL switch is set to ON (TM 9-2320-279-10).</p> | | |
| <p style="padding-left: 40px;">If AUXILIARY PUMP runs, go to Step 8.</p> | | |
| <p style="padding-left: 40px;">If AUXILIARY PUMP does not run, go to Step 2.</p> | | |

Troubleshooting Malfunctions (Cont)
 Table 2-9. Troubleshooting (Cont)

| Malfunction | Test or Inspection | Corrective Action |
|--|--------------------|-------------------|
| TANKER SYSTEM (CONT) | | |
| 5. AUXILIARY PUMP WILL NOT PUMP FUEL (CONT). | | |
| | | |
| NOTE | | |
| Refer to FO-1, Sheet 4, for M978 Electric Diagram. | | |
| Step 2. Remove control junction box cover (para 7-49). Check resistance across APC AUXILIARY PUMP CONTROL switch terminals when switch is set to ON. | | |
| If there is more than zero ohms resistance, replace APC AUXILIARY PUMP CONTROL switch (para 7-48). | | |
| Step 3. Connect batteries (para 7-91). Check for 24 to 30 vdc to APC AUXILIARY PUMP CONTROL switch. Touch positive (+) probe to terminal with single red wire and negative (-) probe to vehicle. | | |
| If there is 24 to 30 vdc, go to Step 6. | | |
| If no voltage, go to Step 4. | | |

Troubleshooting Malfunctions (Cont)

2-15. TROUBLESHOOTING INSTRUCTIONS (CONT).

Table 2-9. Troubleshooting (Cont)

| Malfunction | Test or Inspection | Corrective Action |
|---|--|---|
| TANKER SYSTEM (CONT) | | |
| 5. AUXILIARY PUMP WILL NOT PUMP FUEL (CONT). | | |
| | | |
| Step 4. | Check for defective wiring. Remove main junction box cover (para 7-47). Check resistance of red wire between APC AUXILIARY PUMP CONTROL switch and main junction box terminal board. | If resistance is more than zero ohms, replace wire, install control and main junction box covers (paras 7-47 and 7-49). |
| Step 5. | Check for defective power wire. Check resistance of wire between main junction box terminal board and engine circuit breaker. | If resistance is more than zero ohms, replace wire, install control and main junction box covers (paras 7-47 and 7-49). |

Troubleshooting Malfunctions (Cont)

Table 2-9. Troubleshooting (Cont)

| Malfunction | Test or Inspection | Corrective Action |
|--|--|---|
| TANKER SYSTEM (CONT) | | |
| 5. AUXILIARY PUMP WILL NOT PUMP FUEL (CONT). | | |
| <p>The diagram illustrates the electrical components of the auxiliary pump system. It shows a perspective view of the auxiliary pump junction box with its cover removed, revealing internal wiring and a ground stud. A separate view shows the relay terminal E3 with a red wire connected to it. Another view shows the APC switch with a red wire connected to its terminal. Labels include: RELAY TERMINAL E3, GROUND STUD, AUXILIARY PUMP JUNCTION BOX, RED WIRE TO RELAY TERMINAL E3, and APC SWITCH.</p> | | |
| Step 6. | Check for defective auxiliary pump power wire. Remove auxiliary pump junction box cover (para 7-48). Check resistance of red wire between relay terminal E3 and APC AUXILIARY PUMP CONTROL switch. | If resistance is more than zero ohms, replace wire, install main, control, and auxiliary pump junction box covers (paras 7-47, 7-48, and 7-49). |
| NOTE | | |
| <ul style="list-style-type: none"> • There are two model configurations when working on auxiliary pump system. Model B incorporates a ground strap from auxiliary pump junction box to auxiliary pump. Model A does not incorporate this ground strap. • Perform step (6.1) only if working on Model B. | | |
| Step 6.1. | Check for defective or poor auxiliary pump junction box ground. Check resistance between ground stud in auxiliary pump junction box and a known good ground. | If resistance is more than zero ohms, replace ground strap from auxiliary pump junction box to auxiliary pump. |

Troubleshooting Malfunctions (Cont)

Table 2-9. Troubleshooting (Cont)

| Malfunction | Test or Inspection | Corrective Action |
|--|---|---|
| TANKER SYSTEM (CONT) | | |
| 5. AUXILIARY PUMP WILL NOT PUMP FUEL (CONT). | | |
| <p>The diagram illustrates the electrical components for the auxiliary pump system. It includes a perspective view of the junction box with its cover removed, showing internal wiring and components. Labels point to the 'RELAY TERMINAL A5', 'RELAY', 'AUXILIARY PUMP JUNCTION BOX', 'BLUE WIRE', and 'APC SWITCH'. A separate view shows the 'APC SWITCH' in detail, which is a rotary switch mounted on a base.</p> | | |
| Step 7. | Check for defective auxiliary pump relay ground wire. Disconnect blue wire from auxiliary pump junction box and relay terminal A5. Check resistance of blue wire. | If resistance is more than zero ohms, replace wire, install main, control, and auxiliary pump junction box covers (paras 7-47, 7-48, and 7-49). |
| Step 8. | Connect batteries (para 7-91). Check for defective auxiliary pump relay. Set APC AUXILIARY PUMP CONTROL switch to ON. | If AUXILIARY PUMP does not run, replace auxiliary pump relay (para 7-48), install main and control junction box covers (paras 7-47 and 7-49). |

Troubleshooting Malfunctions (Cont)

2-15. TROUBLESHOOTING INSTRUCTIONS (CONT).

Table 2-9. Troubleshooting (Cont)

| Malfunction | Test or Inspection | Corrective Action |
|---|--------------------|-------------------|
| TANKER SYSTEM (CONT) | | |
| 5. AUXILIARY PUMP WILL NOT PUMP FUEL (CONT). | | |
| <p>Step 9. Check for fuel in V16 AUXILIARY PUMP CHECK VALVE. Remove cap. Check for damage, dirt, and debris. If no fuel, AUXILIARY PUMP must be primed.</p> | | |
| <p>Remove disk assembly from V16 AUXILIARY PUMP CHECK VALVE. Remove dirt and debris. Pour about 1 gal (4 L) of fuel in tank into V16 AUXILIARY PUMP CHECK VALVE. Install disk assembly and cap. Replace damaged V16 AUXILIARY PUMP CHECK VALVE disk or spring (para 25-29).</p> | | |
| | | |
| <p>Step 10. Remove auxiliary pump inlet piping (para 25-11, pipe No. 2). Check piping and AUXILIARY PUMP for dirt and debris,</p> | | |
| <p>Remove dirt and debris from piping and auxiliary pump inlet.</p> | | |
| <p>Step 11. Remove auxiliary pump outlet to V16 AUXILIARY PUMP CHECK VALVE piping (para 25-11, pipe No. 7). Check piping and AUXILIARY PUMP for dirt and debris.</p> | | |
| <p>Remove dirt and debris from piping and auxiliary pump outlet.</p> | | |
| <p>If problem remains, replace AUXILIARY PUMP (para 25-7).</p> | | |

Troubleshooting Malfunctions (Cont)
 Table 2-9. Troubleshooting (Cont)

| Malfunction | Test or Inspection | Corrective Action |
|--|--------------------|-------------------|
| TANKER SYSTEM (CONT) | | |
| 6. FUEL SERVICING RATE IS SLOW OR NO FLOW. | | |
| NOTE | | |
| AUXILIARY PUMP is designed for 25 GPM (95 L) fuel flow and primary pump for 300 GPM (1135 L) flow rate. | | |
| Step 1. Check if V3 suction line valve is binding or sticking when opening or closing (TM 9-2320-279-10). | | |
| Replace binding or sticking V3 suction line valve (para 25-17). | | |
| | | |
| Step 2. Check for defective air actuator system. Remove air hose from V5 air actuated flow valve. Operate HAV HAND ACTUATED CONTROL VALVE (TM 9-2320-279-10). Check for air blowing from hose and for continuous exhausting of air from HAV HAND ACTUATED CONTROL VALVE. | | |
| If no air, or if HAV HAND ACTUATED CONTROL VALVE continuously exhausts air, repair HAV HAND ACTUATED CONTROL VALVE (para 18-16). | | |
| Step 3. Check that V5 air actuated flow valve fully opens. Open V5 air actuated flow valve with wrench. | | |
| Replace defective V5 air actuated flow valve (para 25-19). | | |
| Step 4. Remove VT VENTURI piping (para 25-11 and 25-36) and check VT VENTURI and piping for damage, dirt, and debris. | | |
| Remove dirt and debris from VT VENTURI and piping. Replace damaged VT VENTURI and piping. | | |

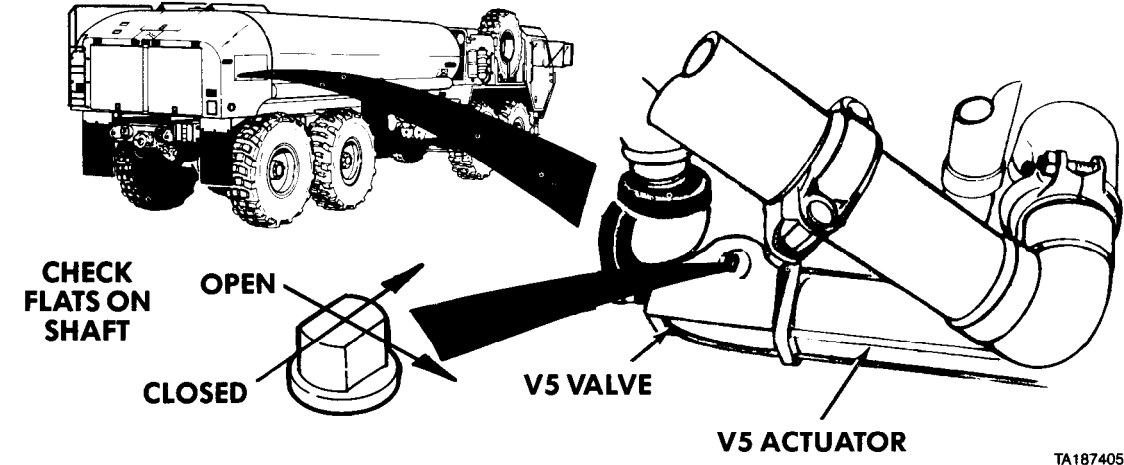
Troubleshooting Malfunctions (Cont)

2-15. TROUBLESHOOTING INSTRUCTIONS (CONT).

Table 2-9. Troubleshooting (Cont)

| Malfunction | Test or Inspection | Corrective Action |
|--|--------------------|---|
| TANKER SYSTEM (CONT) | | |
| 6. FUEL SERVICING RATE IS SLOW OR NO FLOW (CONT). | | <p data-bbox="185 636 1377 695">Step 5. Remove V7/V8 REEL VALVE piping (para 25-11 and 25-22). Check for damage, dirt, and debris in or around V7/V8 REEL VALVE and in piping.</p> <p data-bbox="406 710 1334 736" style="padding-left: 40px;">Remove dirt and debris. Replaced damaged V7/V8 REEL VALVE and piping.</p> <p data-bbox="185 774 1407 834">Step 6. Remove piping from both sides of flowmeter (para 25-11). Check piping and flowmeter for damage, dirt, and debris.</p> <p data-bbox="406 849 1410 908" style="padding-left: 40px;">Remove dirt and debris. Replace damaged piping. If flowmeter is damaged, notify the supervisor.</p> <p data-bbox="185 932 1146 957">Step 7. Check MC MANUAL CONTROL VALVE cable adjustment (para 25-15).</p> <p data-bbox="406 972 961 998" style="padding-left: 40px;">Adjust MC MANUAL CONTROL VALVE cable.</p> <p data-bbox="185 1027 1341 1087">Step 8. Check pressure on DLPG DISCHARGE LINE PRESSURE GAGE while operating pump (TM 9-2320-279-10).</p> <p data-bbox="406 1102 1427 1161" style="padding-left: 40px;">If DLPG DISCHARGE LINE PRESSURE GAGE indicates less than 10 psi (69 kPa), replace servicing pump (AUXILIARY PUMP - para 25-7, primary pump - para 25-6).</p> <p data-bbox="185 1187 865 1212">Step 9. If flow problem remains, notify the supervisor.</p> |
| 7. CANNOT EVACUATE FUEL FROM HOSES OR PRIMARY PUMP STOPS OR FAILS TO DELIVER RATED FLOW. | | <p data-bbox="185 1349 1308 1438">Step 1. Open manhole. Check if fuel flows into tank from V9 CHECK VALVE when V6 FUEL/DEFUEL CONTROL VALVE is set to DEFUEL and primary pump is operated (TM 9-2320-279-10).</p> <p data-bbox="406 1453 640 1478" style="padding-left: 40px;">If not, go to Step 2.</p> <p data-bbox="406 1493 740 1519" style="padding-left: 40px;">If fuel flows, go to Step 13.</p> <p data-bbox="185 1549 1229 1608">Step 2. Check if V3 suction line valve is binding or sticking when opening or closing (TM 9-2320-279-10).</p> <p data-bbox="406 1623 1163 1649" style="padding-left: 40px;">Replace binding or sticking V3 suction line valve (para 25-17).</p> <p data-bbox="185 1678 1367 1738">Step 3. Check pressure on DLPG DISCHARGE LINE PRESSURE GAGE while operating primary pump (TM 9-2320-279-10).</p> <p data-bbox="406 1753 1400 1813" style="padding-left: 40px;">If DLPG DISCHARGE LINE PRESSURE GAGE indicates less than 10 psi (69 kPa), replace primary pump (para 25-6).</p> |

Troubleshooting Malfunctions (Cont)
Table 2-9. Troubleshooting (Cont)

| Malfunction | Test or Inspection | Corrective Action |
|---|--------------------|-------------------|
| TANKER SYSTEM (CONT) | | |
| 7. CANNOT EVACUATE FUEL FROM HOSES OR PRIMARY PUMP STOPS OR FAILS TO DELIVER RATED FLOW (CONT). | | |
|  | | |
| <p>Step 4. Check for defective air actuator system. Remove air hose from V5 air actuated flow valve. Operate HAV HAND ACTUATED CONTROL VALVE (TM 9-2320-279-10). Check for air blowing out of hose and for continuous exhausting of air from HAV HAND ACTUATED CONTROL VALVE.</p> | | |
| <p style="padding-left: 40px;">If no air, or if HAV HAND ACTUATED CONTROL VALVE continuously exhausts air, repair HAV HAND ACTUATED CONTROL VALVE (para 18-16).</p> | | |
| <p>Step 5. Check that V5 air actuated flow valve fully opens. Open V5 air actuated flow valve with wrench.</p> | | |
| <p style="padding-left: 40px;">Replace defective V5 air actuated flow valve (para 25-19).</p> | | |
| <p>Step 6. Check flow limiting valve and piping for damage, dirt, and debris (para 25-11, pipes 5 and 8).</p> | | |
| <p style="padding-left: 40px;">Remove dirt and debris from flow limiting valve and piping. Replace damaged piping. Replace damaged flow limiting valve (para 25-34).</p> | | |
| <p>Step 7. Remove filter-separator cover (para 23-4). Check for dirt and debris.</p> | | |
| <p style="padding-left: 40px;">Replace dirty filter-separator elements.</p> | | |
| <p>Step 8. Remove V6 FUEL/DEFUEL CONTROL VALVE (para 25-20) and piping (para 25-11). Check for damage, dirt, and debris.</p> | | |
| <p style="padding-left: 40px;">Remove dirt and debris. Replace damaged V6 FUEL/DEFUEL CONTROL VALVE.</p> | | |
| <p>Step 9. Remove eductor (para 25-33) and piping (para 25-11). Check for damage, dirt, and debris.</p> | | |
| <p style="padding-left: 40px;">Remove dirt and debris. Replace damaged eductor or damaged piping.</p> | | |

Troubleshooting Malfunctions (Cont)

2-15. TROUBLESHOOTING INSTRUCTIONS (CONT).

Table 2-9. Troubleshooting (Cont)

| Malfunction | Test or Inspection | Corrective Action |
|---|--|--|
| TANKER SYSTEM (CONT) | | |
| 7. CANNOT EVACUATE FUEL FROM HOSES OR PRIMARY PUMP STOPS OR FAILS TO DELIVER RATED FLOW (CONT). | | |
| | Step 10. Remove V9 CHECK VALVE (para 25-23) and piping (para 25-11). Check for damage, dirt, and debris. | Repair damaged V9 CHECK VALVE, replace damaged piping. Remove dirt and debris. |
| | Step 11. Check MC MANUAL CONTROL VALVE cable adjustment (para 25-15). | Adjust MC MANUAL CONTROL VALVE cable. |
| | Step 12. Check H1 and H2 hoses for damage, dirt, and debris. | Remove dirt and debris. Replace damaged hoses (para 16-40). |
| | Step 13. Remove V7 or V8 REEL VALVE (para 25-22). Check for damage, dirt, and debris. | Remove dirt and debris. Replace damaged V7 or V8 REEL VALVE. |
| | Step 14. Remove VT VENTURI and piping to flowmeter (paras 25-36 and 25-11). Check for damage, dirt, and debris. | Remove dirt and debris. Replace damaged piping or damaged VT VENTURI. |
| | Step 15. Remove piping from AE AIR ELIMINATOR to flowmeter (para 25-11). Check for damage, dirt, and debris. | Remove dirt and debris. Replace damaged piping. |
| | Step 16. Remove V6 FUEL/DEFUEL CONTROL VALVE and piping from AE AIR ELIMINATOR (para 25-20 and 25-11). Check for damage, dirt, and debris. | Remove dirt and debris. Replace damaged piping. |
| | Step 17. Remove V6 FUEL/DEFUEL CONTROL VALVE to eductor piping (para 25-11). Check for damage, dirt, and debris. | Remove dirt and debris. Replace damaged piping. |
| | Step 18. Remove V1 emergency valve and piping (para 25-12 and para 25-11). Check for damage, dirt, and debris. | Remove dirt and debris. Replace damaged piping or V1 emergency valve. |

Troubleshooting Malfunctions (Cont)
 Table 2-9. Troubleshooting (Cont)

| Malfunction | Test or Inspection | Corrective Action |
|--|--------------------|--|
| TANKER SYSTEM (CONT) | | |
| 8. PRIMARY PUMP MAKES EXCESSIVE NOISE. | | |
| | | <p>Step 1. Check that primary pump and motor mounting hardware is tight and not damaged. Tighten loose mounting hardware and replace damaged parts (paras 25-5 and 25-6).</p> <p>Step 2. Remove inspection cover from primary pump. Check to see that pump motor coupling is not loose or damaged. Tighten loose coupling or replace damaged parts (para 25-5 and 25-6).</p> |

TA187414

Troubleshooting Malfunctions (Cont)

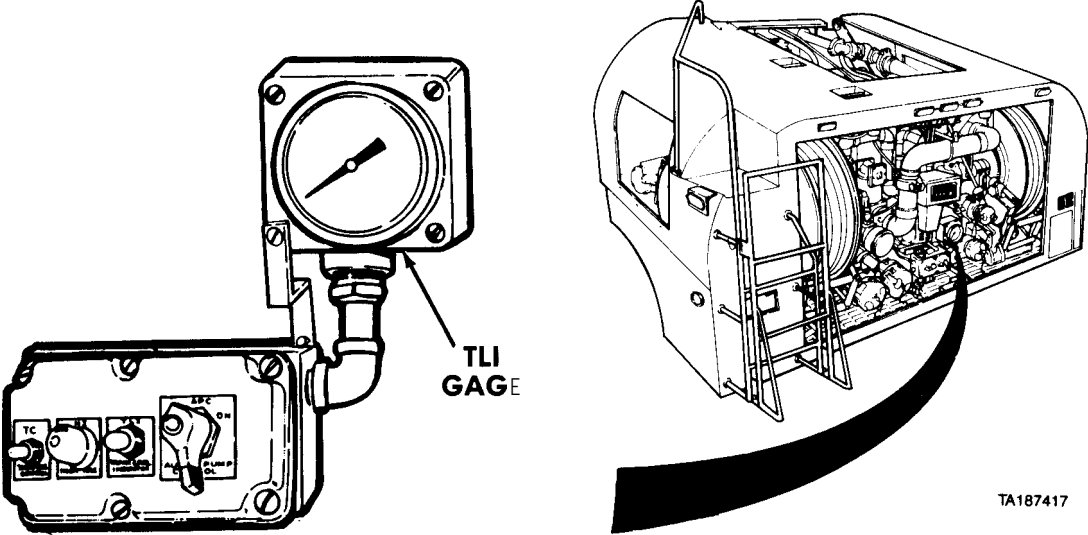
2-15. TROUBLESHOOTING INSTRUCTIONS (CONT)

Table 2-9. Troubleshooting (Cont)

| Malfunction Test or Inspection | Corrective Action |
|---|---|
| TANKER SYSTEM (CONT) | |
| <p>9. AUXILIARY PUMP FAILS TO DELIVER RATED FLOW.</p> | <div data-bbox="247 617 1321 1127" style="text-align: center;"> </div> <p>Step 1. Check for fuel leaks and damage all around AUXILIARY PUMP and auxiliary pump piping. Tighten loose connections. Replace damaged piping, leaking gaskets, or leaking AUXILIARY PUMP (paras 25-11, 25-7).</p> <p>Step 2. Remove AUXILIARY PUMP (para 25-7). Check volute housing for damage, dirt, and debris. Remove dirt and debris. Replace damaged AUXILIARY PUMP.</p> <p>Step 3. Refer to MALFUNCTION 6, FUEL SERVICING RATE IS SLOW OR NO FLOW.</p> |
| <p>10. AUXILIARY PUMP MAKES EXCESSIVE NOISE.</p> | <p>Step 1. Check that AUXILIARY PUMP and motor mounting hardware is tight and not damaged. Tighten loose mounting hardware and replace damaged parts (para 25-7).</p> <p>Step 2. Remove AUXILIARY PUMP (para 25-7). Check volute housing for damage, dirt, and debris. Remove dirt and debris. Replace damaged AUXILIARY PUMP.</p> |

Troubleshooting Malfunctions (Cent)

Table 2-9. Troubleshooting (Cent)

| Malfunction | Test or Inspection | Corrective Action |
|---|--------------------|-------------------|
| TANKER SYSTEM (CONT) | | |
| II. TANK LEVEL INDICATOR GAGE DOES NOT REGISTER PROPER FUEL LEVEL. | | |
|  <p style="text-align: right; margin-right: 100px;">TA187417</p> | | |
| <p>Step 1. Check for jammed needle on TLI TANK LEVEL INDICATOR gage. Tap dial face with hand. Replace jammed TLI TANK LEVEL INDICATOR gage (para 7-86).</p> | | |
| NOTE | | |
| <ul style="list-style-type: none"> • The HEMTT tanker may be equipped with one of two types of fuel level sensors. Each particular type of sensor has its own unique tank level indicator (TLI). One type, Model A, has a plastic fuel level sensor while the other type, Model B, has a brass fuel level sensor. Refer to TM 9-2320-279-34P for correct ordering instructions. • Tanker manhole must be closed when testing Model A tank level indicator. Model A fuel level sensor has phototransistors that are affected by light. • Fuel level sensor will sometimes not read foamy fuel levels. | | |
| <p>Step 2. Check for foamy fuel in tank. Open manhole (TM 9-2320-279-10). Wait until foam settles before going further.</p> | | |
| <p>Step 3. Check for broken fuel level sensor in tank. Replace broken fuel level sensor (para 7-88).</p> | | |

Troubleshooting Malfunctions (Cont)

2-15. TROUBLESHOOTING INSTRUCTIONS (CONT).

Table 2-9. Troubleshooting (Cont)

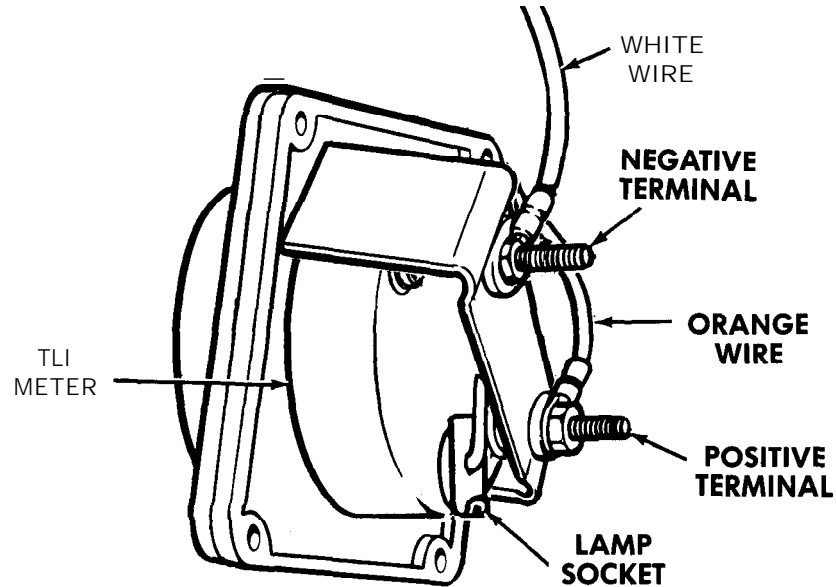
| Malfunction Test or Inspection | Corrective Action |
|---|-------------------|
| TANKER SYSTEM (CONT) | |
| 1. TANK LEVEL INDICATOR GAGE DOES NOT REGISTER PROPER FUEL LEVEL (CONT). | |
| NOTE | |
| <ul style="list-style-type: none"> · There are two models of fuel level sensor. Model A is shown. · Do step 4 for Model A only. | |
| | |
| <p>Step 4. Check for dirty prisms on fuel level sensor. Wipe prisms with clean cloth.</p> | |

Troubleshooting Malfunctions (Cont)
 Table 2-9. **Troubleshooting (Cont)**

| Malfunction | Test or Inspection | Corrective Action |
|-------------|--------------------|-------------------|
|-------------|--------------------|-------------------|

TANKER SYSTEM (CONT)

11. TANK LEVEL INDICATOR GAGE DOES NOT REGISTER PROPER FUEL LEVEL (CONT).



TA187419

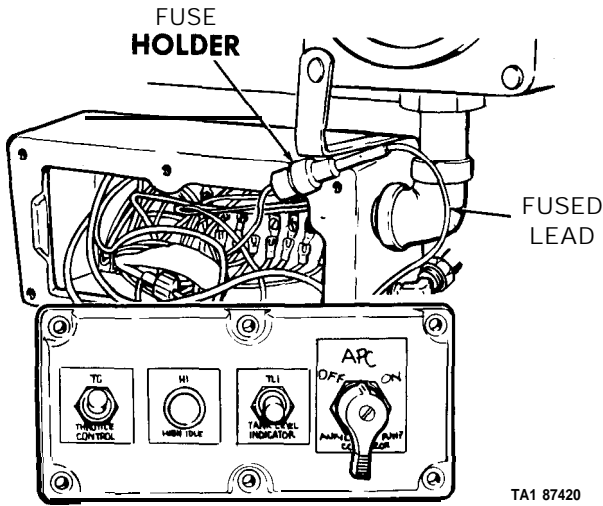
Step 5. Check for defective TLI TANK LEVEL INDICATOR gage. Remove orange and white wires. Remove lamp socket. Apply 24vdc to positive (+) terminal and momentarily short the negative (-) terminal of TLI TANK LEVEL INDICATOR gage to ground. Needle should jump to FULL mark.

Replace defective TLI TANK LEVEL INDICATOR gage (para 7-86).

Troubleshooting Malfunctions (Cent)

2-15. TROUBLESHOOTING INSTRUCTIONS (CONT).

Table 2-9. Troubleshooting (Cent)

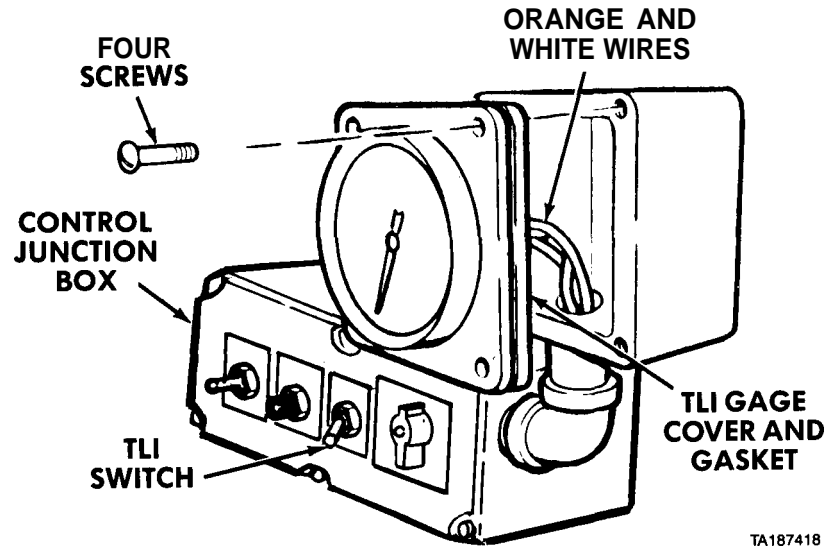
| Malfunction | Test or Inspection | Corrective Action |
|--|--------------------|-------------------|
| TANKER SYSTEM (CONT) | | |
| I 1. TANK LEVEL INDICATOR GAGE DOES NOT REGISTER PROPER FUEL LEVEL (CONT) . | | |
|  <p style="text-align: right; margin-right: 50px;">TA1 87420</p> | | |
| NOTE | | |
| <p>From this point on, do not install junction box covers, gage covers, or operate tanker until problem is solved and this manual says to do so. Refer to FO- 1, sheets 3 and 4 for M978 Electric Diagram.</p> | | |
| <p>Step 6. Remove control junction box cover (para 7-49). Disconnect fuse holder and look for blown fuse.</p> | | |
| <p>Replace blown fuse.</p> | | |
| <p>Step 7. Remove fused lead from TLI TANK LEVEL INDICATOR and APC AUXILIARY PUMP CONTROL switches. Check wire resistance.</p> | | |
| <p style="text-align: center;">If resistance is more than zero ohms between fuse holder and wire terminals, replace fused lead.</p> | | |
| <p>Step 8. Check for defective TLI TANK LEVEL INDICATOR switch. Disconnect connectors. Check switch resistance when TLI TANK LEVEL INDICATOR switch is in the ON position.</p> | | |
| <p style="text-align: center;">If resistance is more than zero ohms, replace defective TLI TANK LEVEL INDICATOR switch (para 7-49), install TLI TANK LEVEL INDICATOR gage cover (para 7-86).</p> | | |

Troubleshooting Malfunctions (Cont)
Table 2-9. Troubleshooting (Cont)

| Malfunction | Test or Inspection | Corrective Action |
|-------------|--------------------|-------------------|
|-------------|--------------------|-------------------|

TANKER SYSTEM (CONT)

11. TANK LEVEL INDICATOR GAGE DOES NOT REGISTER PROPER FUEL LEVEL (CONT).



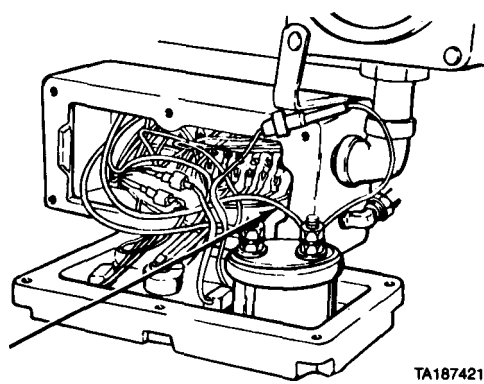
Step 9. Check for defective TLI TANK LEVEL INDICATOR gage to terminal board wiring. Disconnect orange and white wires from TLI TANK LEVEL INDICATOR gage and control junction box terminal board. Check resistance of each wire.

If resistance is more than zero ohms in either wire, replace defective wire, install TLI TANK LEVEL INDICATOR gage cover and control junction box cover (para 7-49).

Troubleshooting Malfunctions (Cent)

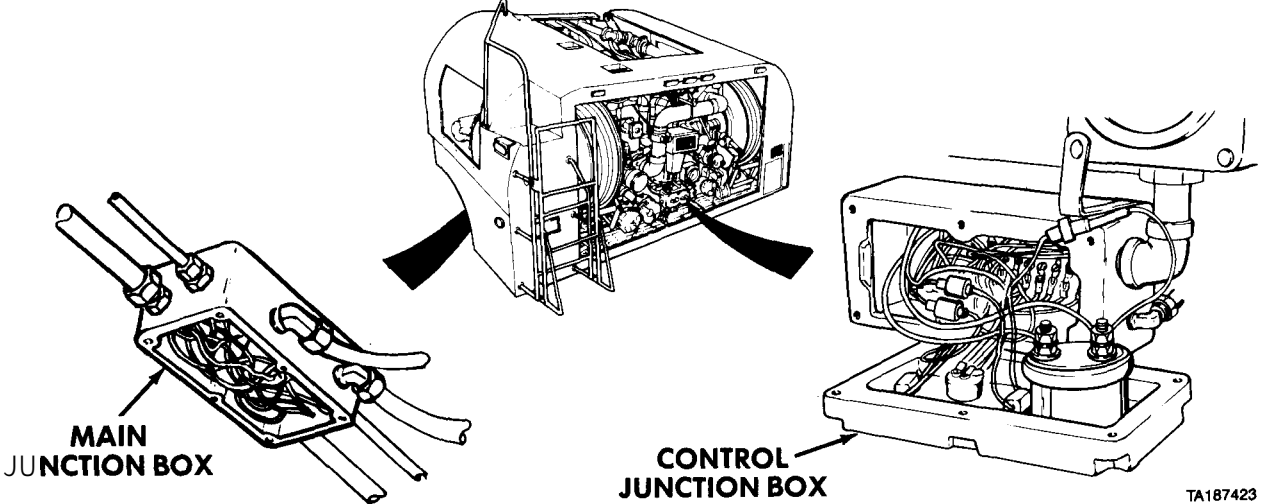
12-15. TROUBLESHOOTING INSTRUCTIONS (CONT).

Table 2-9. Troubleshooting (Cent)

| Malfunction Test or Inspection | Corrective Action |
|--|-------------------|
| TANKER SYSTEM (CONT) | |
| 11. TANK LEVEL INDICATOR GAGE DOES NOT REGISTER PROPER FUEL LEVEL (CONT). | |
|  <p>The diagram shows a mechanical assembly, likely a fuel level indicator, with various wires connected to it. A specific wire is highlighted in yellow and labeled 'YELLOW WIRE' with a line pointing to it. The assembly is mounted on a base and has a cover partially open. The diagram is labeled 'TA187421' in the bottom right corner.</p> | |
| <p>Step 10. Check for defective TLI TANK LEVEL INDICATOR switch wire to terminal board. Disconnect connector. Check resistance of yellow wire from connector to terminal board.</p> | |
| <p>If resistance is more than zero ohms, replace defective TLI TANK LEVEL INDICATOR switch wire, install main and control junction box covers (paras 7-47 and 7-49).</p> | |
| <p>Step 11. Check for defective TLI TANK LEVEL INDICATOR ground wire. Check resistance of blue wire from terminal board to ground point.</p> | |
| <p>If resistance is more than zero ohms, replace wire.</p> | |

Troubleshooting Malfunctions (Cont)

Table 2-9. Troubleshooting (Cont)

| Malfunction | Test or Inspection | Corrective Action |
|---|--------------------|-------------------|
| TANKER SYSTEM (CONT) | | |
| 11. TANK LEVEL INDICATOR GAGE DOES NOT REGISTER PROPER FUEL LEVEL (CONT) . | | |
|  <p style="text-align: right; margin-right: 50px;">TA187423</p> | | |
| <p>Step 12. Check for defective tank level indicator wiring between control junction box and main junction box. Disconnect yellow, orange, white, and blue tank level indicator wires from both junction boxes. Check resistance.</p> | | |
| <p style="padding-left: 40px;">If resistance in any wire is more than zero ohms, replace defective wire between terminal boards.</p> | | |

Troubleshooting Malfunctions (Cent)

2-15. TROUBLESHOOTING INSTRUCTIONS (CONT).

Table 2-9. Troubleshooting (Cent)

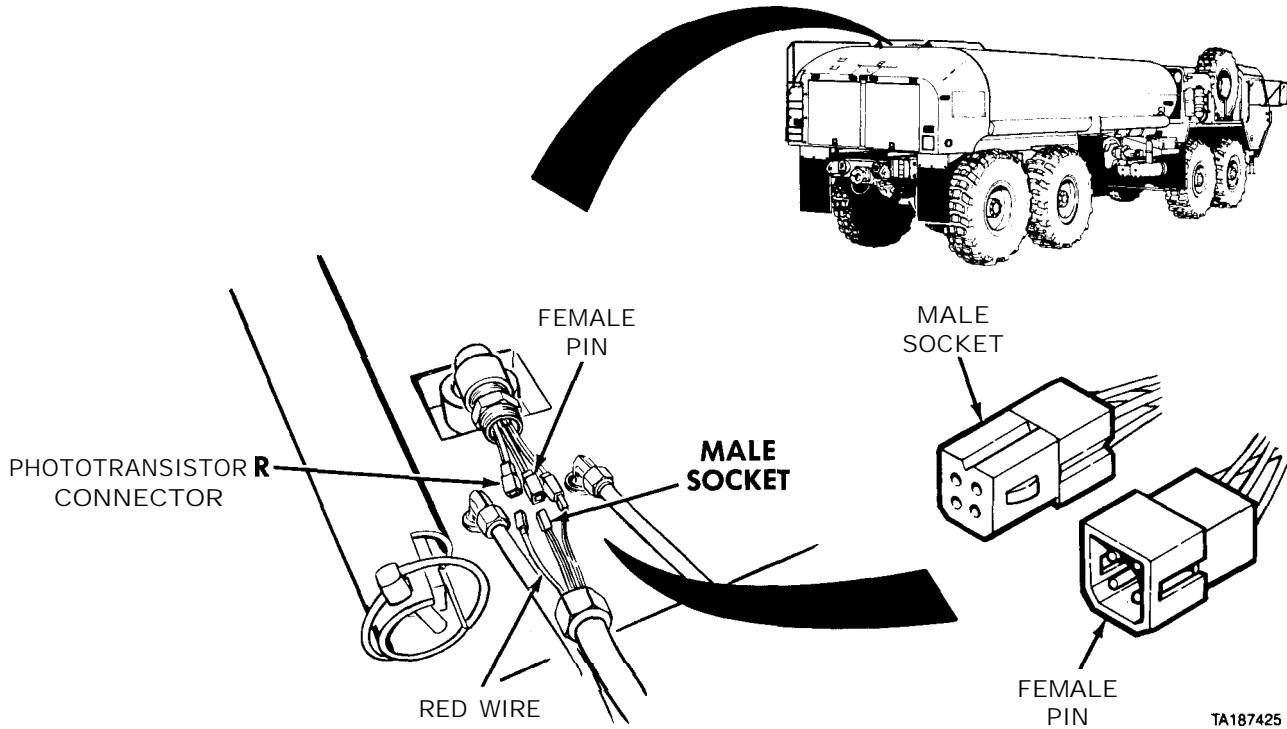
| Malfunction | Test or Inspection | Corrective Action |
|-------------|--------------------|-------------------|
|-------------|--------------------|-------------------|

TANKER SYSTEM (CONT)

11. TANK LEVEL INDICATOR GAGE DOES NOT REGISTER PROPER FUEL LEVEL (CONT).

NOTE

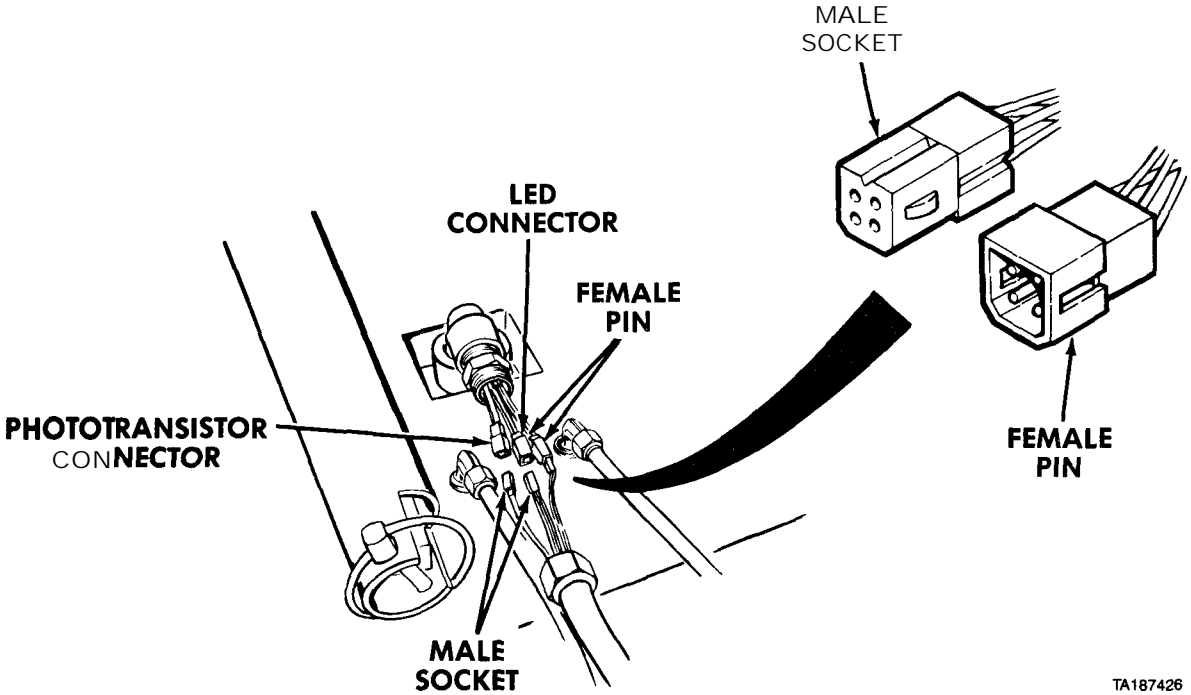
From this point on, the tests for Model A (plastic sensor) and Model B (brass sensor) are different. Do steps 13 through 16 for Model A and steps 17 and 18 for Model B.



Step 13. Connect batteries (para 7-91). Check for defective TLI TANK LEVEL INDICATOR adjuster. Disconnect red wire connector. Disconnect phototransistor connector (male socket and female pin). Set TLI TANK LEVEL INDICATOR switch to ON. Check for 1.2 to 8.0vdc on each female pin, using red wire as ground.

If voltage is lower than 1.2vdc or higher than 8.0vdc, replace tank level indicator adjuster (para 7-87) and install main junction box cover (para 7-47).

Troubleshooting Malfunctions (Cont)
Table 2-9. Troubleshooting (Cont)

| Malfunction | Test or Inspection | Corrective Action |
|---|--------------------|-------------------|
| TANKER SYSTEM (CONT) | | |
| 11. TANK LEVEL INDICATOR GAGE DOES NOT REGISTER PROPER FUEL LEVEL (CONT) . | | |
|  | | |
| TA187426 | | |
| <p>Step 14. Disconnect phototransistor connector. Set TLI TANK LEVEL INDICATOR switch to ON. Ground each female pin of phototransistor connector (male socket and female pin). Check that TLI TANK LEVEL INDICATOR gage drops from FULL to approximately 3/4.</p> | | |
| <p style="padding-left: 40px;">If TLI TANK LEVEL INDICATOR gage does not drop from FULL to approximately 3/4, replace tank level indicator adjuster (para 7-87) and install main junction box cover (para 7-47).</p> | | |
| <p>Step 15. Disconnect LED connector (female pin and male socket). Set TLI TANK LEVEL INDICATOR switch to ON. Check for 24 to 28vdc at each female pin.</p> | | |
| <p style="padding-left: 40px;">If voltage is less than 24vdc, replace tank level indicator adjuster (para 7-87).</p> | | |
| <p>Step 16. If TLI TANK LEVEL INDICATOR gage does not register, replace fuel level sensor (para 7-88).</p> | | |

Troubleshooting Malfunctions (Cont)

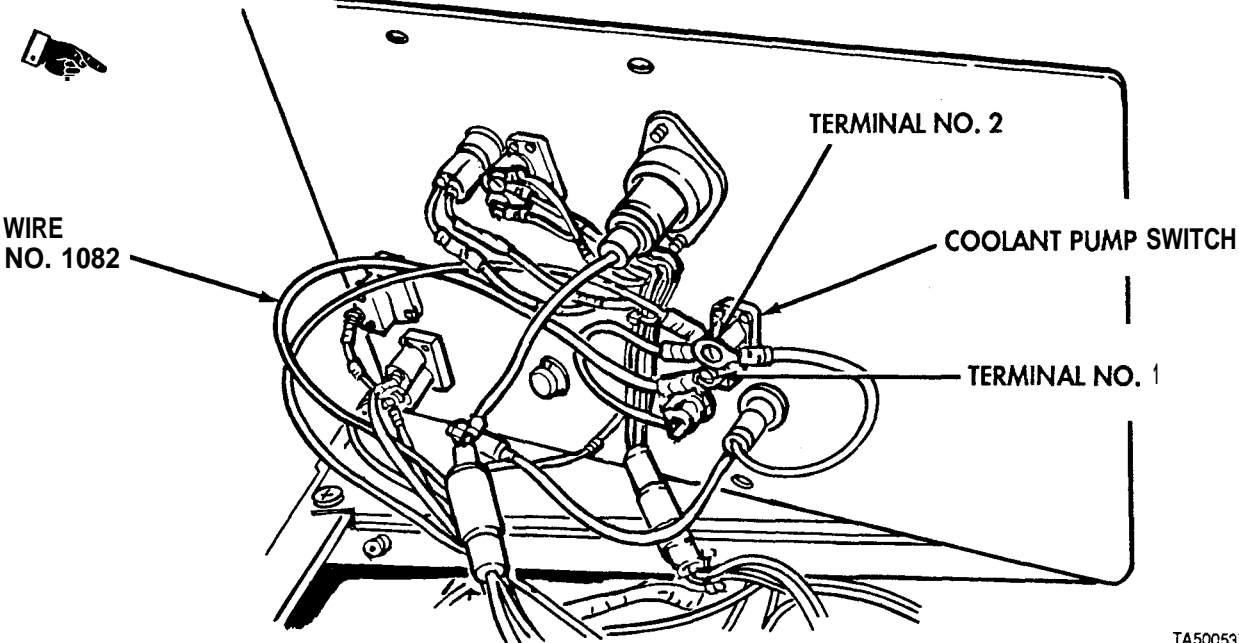
2-15. TROUBLESHOOTING INSTRUCTIONS (CONT).

Table 2-9. Troubleshooting (Cont)

| Malfunction | Test or Inspection | Corrective Action |
|--|---|--|
| TANKER SYSTEM (CONT) | | |
| 11. TANK LEVEL INDICATOR GAGE DOES NOT REGISTER PROPER FUEL LEVEL (CONT). | | |
| | | |
| NOTE | | |
| <ul style="list-style-type: none"> • There are two models of fuel level sensor. Model B is shown. • Do step (17) for Model B only. | | |
| Step 17. | Check for defective fuel level sensor. Disconnect two connectors (female pin and male socket). Connect one probe from meter to black wire. Raise all four float switches and hold in up position. Check resistance on red, yellow, blue, and brown wires. | If resistance is more than zero ohms on any wire, replace fuel level sensor (para 7-88). |
| Step 18. | If TLI TANK LEVEL INDICATOR gage does not register, replace tank level indicator adjuster (para 7-87). | |

Troubleshooting Malfunctions (Cent)

Table 2-9. Troubleshooting (Cent)

| Malfunction | Test or Inspection | Corrective Action |
|--|---|--|
| ARCTIC HEATER KIT | | |
| 1. COOLANT PUMP FAILS TO OPERATE (INDICATOR LIGHT DOES NOT COME ON). |  | TA500537 |
| | <p>Step 1. Remove heater compartment cover (para 20-2). Check for loose electrical connections at coolant pump switch and circuit breaker connections.</p> | Tighten loose connections. |
| | <p>Step 2. Check for defective circuit breaker No. 4 (fig. 2-2), Test voltage across circuit breaker No. 4.</p> | <p>If 24 vdc is present, go to Step 3. If 24 vdc is not present, replace circuit breaker No. 4 (para 7-43)</p> |
| | <p>Step 3. Check for voltage at terminal No. 1 of coolant pump switch. Place positive (+) probe on terminal No. 1. Place negative (-) probe on known good ground.</p> | <p>If 24 vdc is present, go to Step 4. If 24 vdc is not present, repair or replace wire No. 1082.</p> |
| | <p>Step 4. Check for voltage at terminal No. 2 of coolant pump switch. With switch in ON position, place positive (+) probe on terminal No. 2. Place negative (-) probe on known good ground.</p> | <p>If 24 vdc is present, go to Step 5. If there is no voltage, replace coolant pump switch (para 20-2).</p> |
| | <p>Step 5. If problem has not been solved, notify the supervisor.</p> | |

Troubleshooting Malfunctions (Cent)

2-13. TROUBLESHOOTING INSTRUCTIONS (CONT).

Table 2-9. Troubleshooting (Cent)

| Malfunction | Test or Inspection | Corrective Action |
|---|--------------------|-------------------|
| ARCTIC HEATER KIT (CONT) | | |
| 1. COOLANT PUMP FAILS TO OPERATE (INDICATOR LIGHT DOES NOT GO ON) (CONT). | | |
| <p>The diagram shows a three-terminal receptacle (1, 3, 1070) connected to a switch and an indicator light. The switch controls both the coolant pump motor and a 15A circuit breaker. The indicator light is connected to terminal 1082 and ground. The coolant pump motor is connected to terminal 1317 and ground. An existing ground for PTO light is also indicated.</p> | | |
| TA500403 | | |
| <i>Figure 2-15. Arctic Heater Kit Wiring Diagram</i> | | |

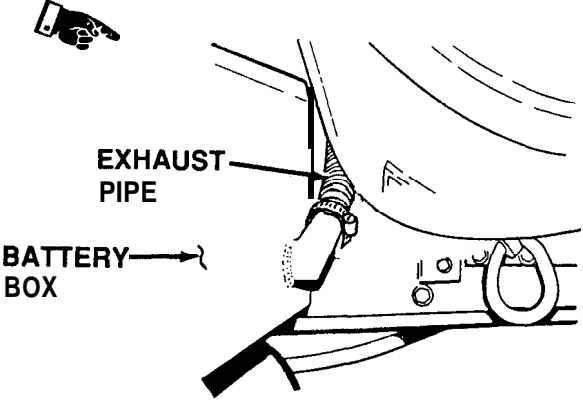
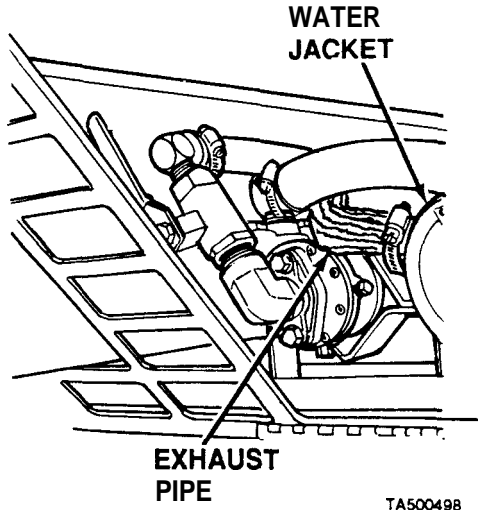
Troubleshooting Malfunctions (Cent)
Table 2-9. Troubleshooting (Cent)

| Malfunction Test or Inspection | Corrective Action |
|--|-------------------|
| ARCTIC HEATER KIT | |
| 2. COOLANT PUMP FAILS TO OPERATE (INDICATOR LIGHT COMES ON). | |
| | |
| TA500405 | |
| <p>Step 1. Check coolant pump for loose electrical connections. Tighten loose connections.</p> <p>Step 2. Check voltage at coolant pump. Place positive (+) probe at terminal No. 4. Place negative (-) probe on known good ground. If 24 vdc is present, go to Step 3. If 24 vdc is not present, repair or replace wire No. 1530 (para 20-2).</p> <p>Step 3. Perform continuity check on ground wire No. 1317 of coolant pump. If continuity is present, repair or replace coolant pump (para 20-2). If continuity is not present, repair or replace wire No. 1317.</p> <p>Step 4. If problem has not been solved, notify the supervisor.</p> | |

Troubleshooting Malfunctions (Cent)

2-13. TROUBLESHOOTING INSTRUCTIONS (CONT).

Table 2-9. Troubleshooting (Cent)

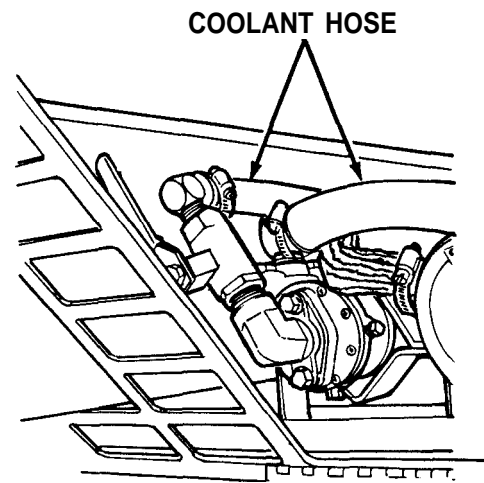
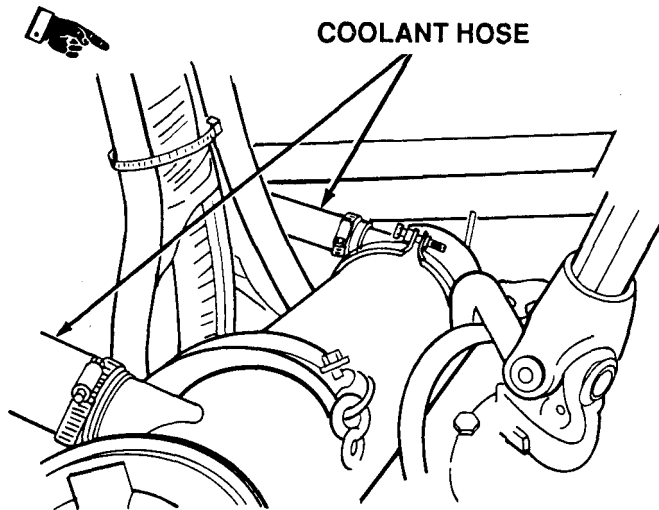
| Malfunction | Test or Inspection | Corrective Action |
|---|--|-------------------|
| ARCTIC HEATER KIT (CONT) | | |
| 3. HEAT OUTPUT TO BATTERY BOX TOO LOW. | | |
|  <p>A hand is shown pointing to the connection of the exhaust pipe to the battery box. Labels include 'EXHAUST PIPE' and 'BATTERY BOX'.</p> |  <p>A diagram of the engine compartment showing the water jacket and exhaust pipe. Labels include 'WATER JACKET' and 'EXHAUST PIPE'. The reference number TA500498 is located at the bottom right of the diagram.</p> | |
| | <p>Step 1. Check exhaust pipe connections at water jacket and battery box. Tighten loose connections.</p> <p>Step 2. Check exhaust pipe for kinks or damage. Repair or replace exhaust pipe (para 20-2).</p> <p>Step 3. If problem has not been solved, notify the supervisor.</p> | |

Troubleshooting Malfunctions (Cent)
 Table 2-9. Troubleshooting (Cent)

| Malfunction | Test or Inspection | Corrective Action |
|-------------|--------------------|-------------------|
|-------------|--------------------|-------------------|

ARCTIC HEATER KIT

4. HEATER FAILS TO SUFFICIENTLY WARM ENGINE (COOLANT PUMP OPERATING).



TA500404

- Step 1. Check for restrictions in coolant hoses. Remove coolant hoses (para 20-2).
 Remove any restrictions, install coolant hoses (para 20-2).
 If there are no restrictions, replace arctic heater.
- Step 2. If problem has not been solved, **notify** the supervisor.

Troubleshooting Malfunctions (Cent)

2-13. TROUBLESHOOTING INSTRUCTIONS (CONT).

Table 2-9. Troubleshooting (Cent)

| Malfunction | Test or inspection | Corrective Action |
|----------------------------------|---|---|
| ARCTIC HEATER KIT (CONT) | | |
| 5. CIRCUIT BREAKER OPENS. | | |
| Step 1. | Check arctic heater kit installation for damaged or loose wiring. Remove heater compartment cover (para 20-2). | Tighten loose connections, repair or replace damaged wiring. |
| Step 2, | Check for defective arctic heater starter cable. Test resistance between each end of cable wires, If any wire tested shows more than zero ohms, replace cable. | |
| Step 3. | Replace circuit breaker No. 4 (para 7-43). Restart arctic heater. | If circuit breaker opens, replace arctic heater. , |
| Step 4. | If problem has not been solved, notify the supervisor. | |

All data on pages 2-257 thru 2-269 has been deieted.

STE/ICE Instructions

2-16. SIMPLIFIED TEST EQUIPMENT FOR INTERNAL COMBUSTION ENGINES (STE/ICE) INTRODUCTION

This section of troubleshooting contains procedures for operating the STE/ICE; and troubleshoot M977 series vehicle's internal combustion engines and associated fuel and electrical systems. The procedures cover vehicle serviceability testing and primary fault isolation. This part of the troubleshooting section is applicable only if STE/ICE is available. If STE/ICE is not available, go to paragraph 2-14, Table 2-7, System Symptom Index and Table 2-8, Troubleshooting Subject Index.

STE/ICE Maintenance. Description, operation, and organizational maintenance of STE/ICE system is covered in TM 9-4910-571-12&P.

6. STE/ICE Tests.

(1) **STE/ICE Test Chain Index.** The procedures are arranged in a GO chain (Table 2-10) and a NO-GO chain (Table 2-11). In the GO chain, the satisfactory result (YES) from each test leads to a GO to the next test. If vehicle fails the test in the GO chain, the unsatisfactory result leads to a corrective action, higher level of maintenance, or to the NO-GO chain. The NO-GO chain contains procedures to determine the cause of failure and is arranged in steps detailing fault isolation and corrective action.

(2) **General Use of Test Chains.** The condition of a test vehicle need not be known. The absence of malfunctions would be quickly demonstrated by satisfactory passage (in sequence) of all tests in the GO chain (fig. 2-17). A malfunctioning vehicle will fail one or more GO chain tests, resulting in fault isolation and corrective action. The only symptoms needed to indicate STE/ICE testing are: 1) Engine won't start, 2) Engine won't run right.

Table 2-10. Engine GO Chain index (Combined Mode)

| GO Test Number | Test Title |
|----------------|--|
| GO1 | VTM Connections and Checkout |
| GO2 | First Peak Test - Starter Current |
| GO3 | Engine Start - Lubrication Check |
| GO4 | Charging Circuit and Battery Voltage Test |
| GO5 | Engine Warmup/Coolant Check/Oil Pressure Test/Fuel Filter Restriction Test |
| GO6 | Governor Check/Power Test |
| GO7 | Idle Speed/Governor Check |
| GO8 | Compression Unbalance Test |

Table 2-11. Engine NO-GO Chain Index (Combined Mode)

| NO-GO Test Number | Test Title |
|-------------------|-------------------------------------|
| NG05 | Low Oil Pressure Check |
| NG20 | No Crank - No Start |
| NG30 | Engine Crank- No Start |
| NG31 | Gage Test |
| NG50 | Charging Circuit Tests |
| NG80 | Starter Circuit Tests |
| NG81 | Battery Tests |
| NG90 | Governor/Power Test Fault Isolation |
| NG130 | Engine Tightness Test |

STE/ICE Instructions (Cent)

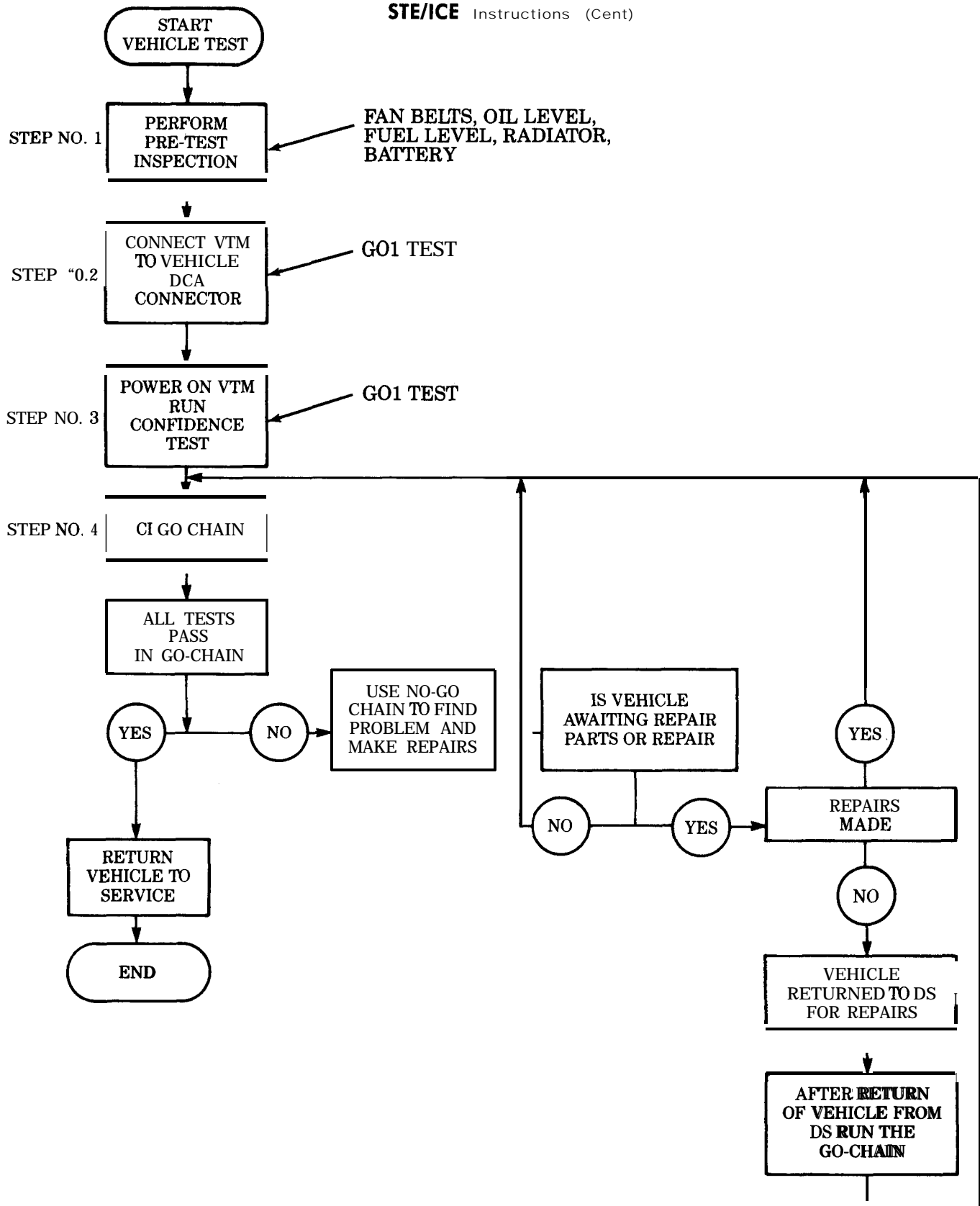


Figure 2-17. **STE/ICE** Vehicle Test.

TA187708

STE/ICE Instructions (Cent)

2-16. SIMPLIFIED TEST EQUIPMENT FOR INTERNAL COMBUSTION ENGINES (STE/ICE)
INTRODUCTION (CONT).

(3) *Isolation and Correction of Specific Malfunctions.* When a specific malfunction is known, unnecessary testing can be avoided by going directly to the appropriate test, or tests, indexed in Table 2-10 or 2-11. The relationship of the GO and NO-GO tests are shown in Figure 2-18. Note that GO1 test, VTM connections and checkout, must be performed before conducting any other tests.

c. **STE/ICE** Operation **and** Description. STE/ICE is a testing system that performs tests and measurements on internal combustion engines. STE/ICE measures standard voltage, current, resistance, pressure, and temperature. Special tests, such as compression balance tests and starter system evaluations are performed by STE/ICE. Standard equipment functions including vacuum pressure gage, low-current tester, and multimeter are features of the STE/ICE set. STE/ICE is portable and operates on either 12 or 24-volt vehicle batteries or equivalent power source. The STE/ICE system consists of a Vehicle Test Meter (VTM), a Transducer Kit (TK), four electrical cables, a transit case, and technical manual (fig. 2-19).

d. Vehicle Test Meter (**VTM**).

(1) *VTM Description.* The VTM is a tool for the mechanic to test vehicle electrical and mechanical components. Readings are either pass/fail indications or digital displays in units familiar to the mechanic (psi, rpm, volts, ohms, amps, etc.).

(2) *VTM Interfaces.* The VTM interfaces with the vehicle by either a permanently mounted Diagnostic Connector Assembly (DCA) or directly with a transducer from the Transducer Kit (TK). The DCA provides accessibility to the most frequently needed test points. This use of the VTM is called the DCA mode of operation. The VTM also interfaces with transducers from the transducer kit for testing or troubleshooting. This use of the VTM is called the TK mode of operation. Additional tests not in the DCA mode can also be done in the Transducer Kit (TK) mode. These involve manually probing and/or connecting transducers to appropriate test points.

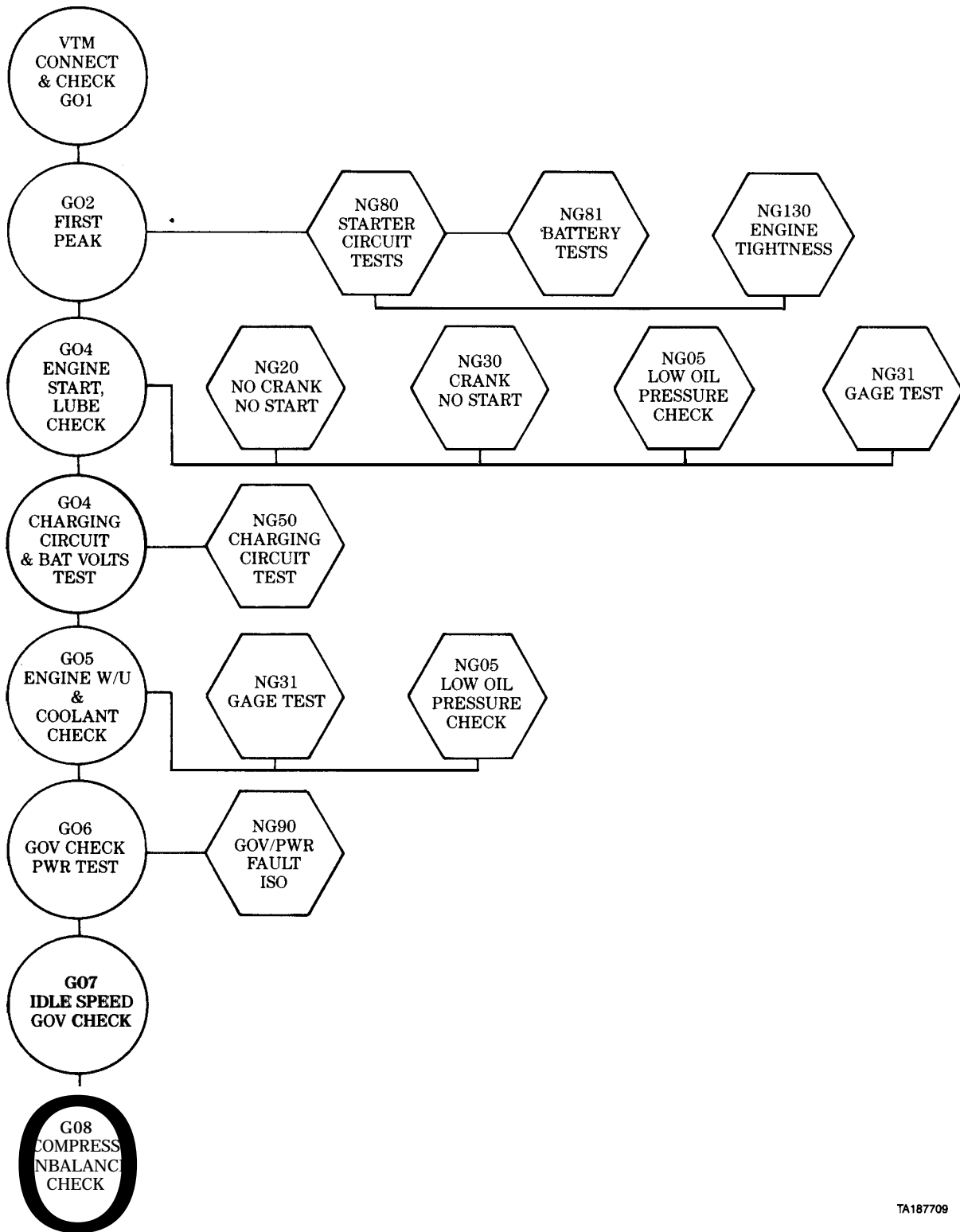
(3) *VTM Power.* Operating power for the VTM is drawn from the vehicle batteries or some equivalent battery source. Power is routed to the VTM through the diagnostic connector in the DCA mode, or through cable clamps connected to the battery in the TK mode.

e. Transducer Kit Components. The Transducer Kit contains a pulse tachometer transducer, a pressure and a vacuum transducer along with the necessary adapters (bushings, plugs, tees, etc.). Also included in the kit is a current probe for measuring current and a test probe cable for measuring voltage and resistance. The transducers and adapters are non-repairable. The cables are non-repairable at organizational maintenance level.

f. Vehicle Test Meter (**VTM**) Controls and Readout Display. The controls and readout display on the VTM are illustrated in Figure 2-20. The following paragraphs describe how the controls are used, and how the display functions.

(1) *Power Switch (PUSH ON/PULL OFF).* The power switch controls DC power to the VTM. The VTM can operate from a 12-volt or 24-volt battery system. When the power switch is pushed in (PUSH ON), the VTM power is on. To shut the VTM off, pull out the power switch (PULL OFF). The power switch contains a 4-amp circuit breaker. The power switch will pop out automatically if something is wrong which causes the VTM to use more power than it should. If the switch pops, check the hookup carefully and try again before sending the VTM to DS Maintenance.

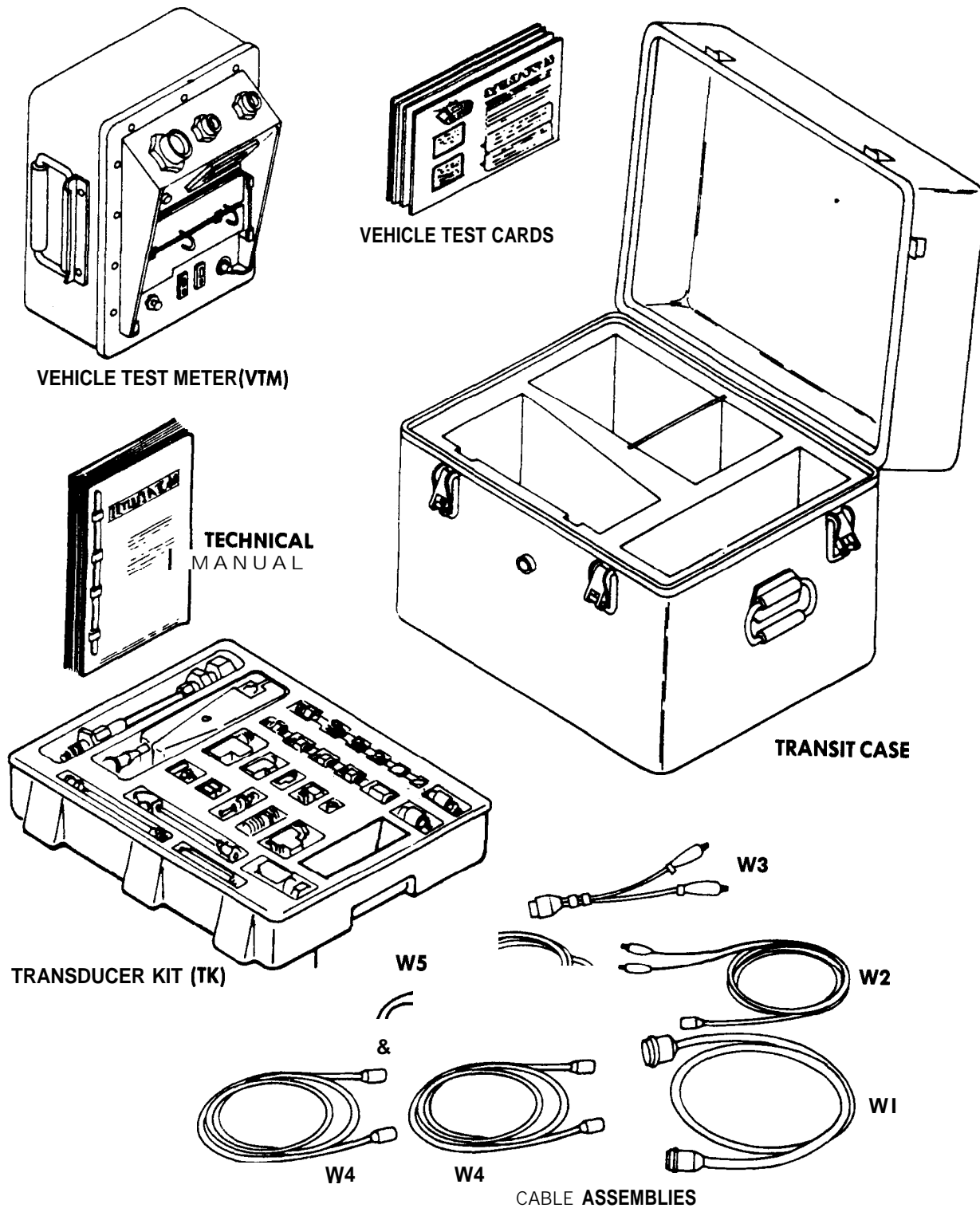
STE/ICE Instructions (Cent)



TA187709

Figure 2-18. Relationship of GO, NO-GO Tests.

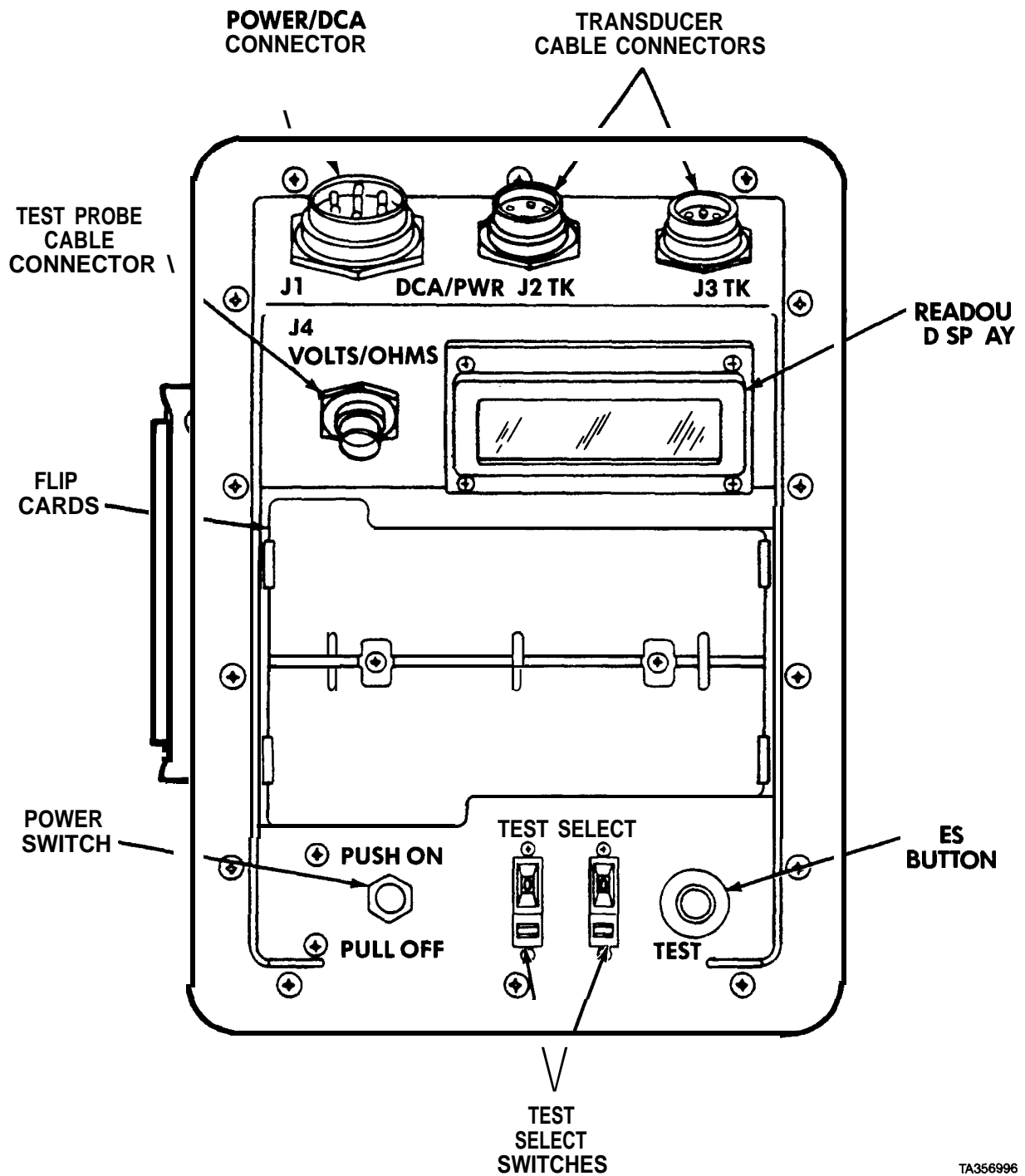
STE/ICE Instructions (Cent)



TA356995

Figure 2-19. STE/ICE System.

STE/ICE Instructions (Cent)



TA356996

Figure 2-20. VTM Controls and Readout Display.

STE/ICE Instructions (Cent)

2-16. SIMPLIFIED TEST EQUIPMENT FOR INTERNAL COMBUSTION ENGINES (STE/ICE)
INTRODUCTION (CONT).

(2) **TEST SELECT SWITCHES.** The TEST SELECT switches are used to select the actual test to be performed. There are ten positions on each switch numbered 0 through 9. The number dialed into these switches is read by the VTM when you press the TEST button. Changing the TEST SELECT switch position has no effect until the TEST button is pushed.

(3) **TEST BUTTON.** Depressing and releasing the TEST button causes the test measurement to begin. The measured value will appear on the readout display. The reading will be in units normally used for the particular vehicle measurement. These units are listed on the flip cards. The TEST BUTTON must be pressed and immediately released. Depressing and holding the TEST BUTTON down initiates an offset test as described in k.(3).

(4) **READOUT DISPLAY.** The READOUT DISPLAY will show different types of readouts during testing up to a maximum of 4 characters (for example .8.8.8.8). The types of readouts are described in detail later in this paragraph but are summarized as follows:

(a) **Status Readout.** This type of readout keeps the operator informed of what is happening such as power applied, failed test, etc.

(b) **Numerical Readout.** This type of readout is the measured value in units of the measurement being made. For example, if measuring 0-45 volts DC, the number 24 on the display indicates 24-volts.

(c) **Error Readout.** This type of readout indicates that, for example, the wrong test number was selected, the transducer is not connected, or the VTM is faulty.

(5) **FLIP CARDS.** The flip cards list the 2-digit test number system for selecting the various tests. The cards also summarize the test operating instructions contained in this chapter.

(6) **POWER/DCA CONNECTOR J1.** Connector J1 connects the VTM to either a vehicle diagnostic connector using the DCA cable, or to the vehicle batteries using the power cable. Operating power and signals from the transducers are supplied to the VTM through the DCA cable.

(7) **TRANSDUCER CABLE CONNECTORS J2 and J3.** Connector J2 or J3 connects the VTM to any transducer in the transducer kit. Operating power is supplied to the transducer and signals from the transducer are supplied to the VTM through the cable. Connectors J2 and J3 are identical and can be interchanged with each other or used in combination.

(8) **TEST PROBE CABLE CONNECTOR J4.** Connector J4 connects test leads to the VTM when doing manual voltage and resistance tests.

g. Cable Assemblies. Cable assemblies are shown in Figure 2-21. Cable assemblies are referred to by cable number and by a name which describes how the cable is used. For example, cable W 1 is the DCA cable, cable W2 is the Test Probe cable, etc. If necessary, the two transducer cables (W4) can be joined with the adapter supplied in the transducer kit to make one long cable. When cables are connected, the large key on the cable connector mates with a keyway on the transducer connector or the VTM connector for proper installation. Figure 2-22 shows how the key and keyway should be lined up. If there is any difficulty during testing, and it is suspected that a cable is bad, refer to TM 9-4910-571-12&P to check cable continuity.

h. Transducer Kit (TK). The Transducer Kit (TK) is shown in Figure 2-23. The kit contains transducers, adapters, and fittings stored in a molded tray. Many of the fittings do not have part number markings. However, the number shown with each item will help to identify the item easily. Before installing any Transducer Kit items on the vehicle, be sure to clean the mounting surfaces. This is particularly important if opening fuel lines or tapping into manifolds. Dirt particles entering the engine can cause damage to both the engine and the transducer kit items. The transducers are precise devices housed in rugged bodies. However, they should be kept clean and handled with reasonable care. In particular, keep the connectors free of dirt and grease.

STE/ICE Instructions (Cent)

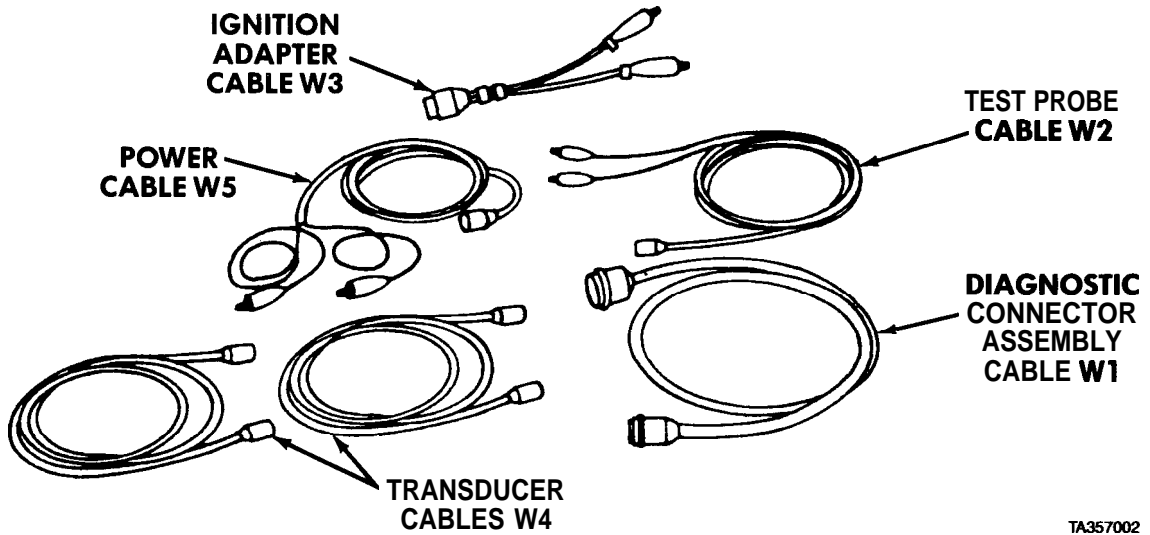


Figure 2-21. Cable Assemblies.

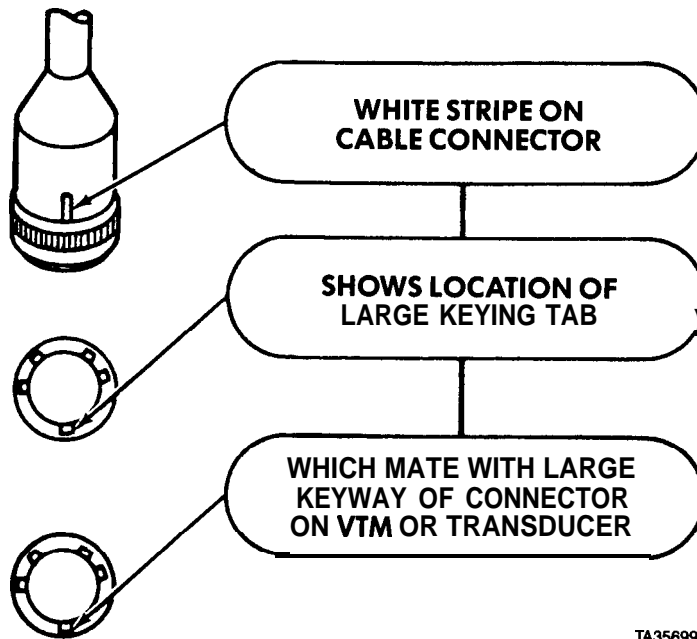
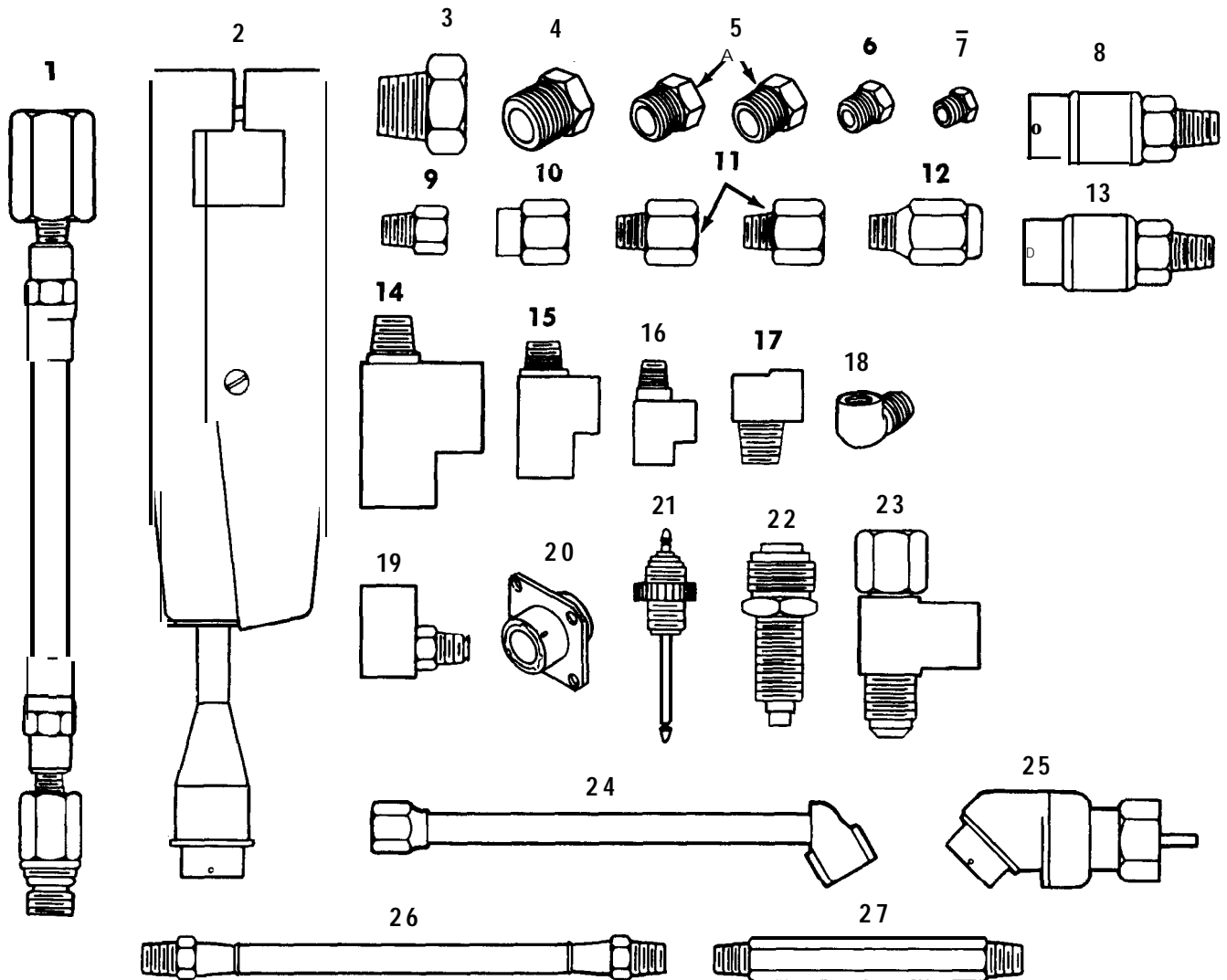


Figure 2-22. Connector Key Location.

STE/ICE Instructions (Cont)



- | | |
|--|--|
| <ul style="list-style-type: none"> 1. TK Item 10- Hose and Fitting Assembly 2. TK Item 11- Current Probe 3. TK Item 12- 3/4 Reducer 4. TK Item 13- 1/2 Reducer 5. TK Item 14- 3/8 Reducer 6. TK Item 15- 1/4 Pipe Plug 7. TK Item 16- 1/8 Pipe Plug 8. TK Item 17- Pressure Transducer - Blue Stripe 9. TK Item 18- 1/4 Male Connector 10. TK Item 19- Pipe Reducer Coupling 11. TK Item 20- Adapter 12. TK Item 21- Snubber 13. TK Item 22- Pressure Transducer - Red Stripe | <ul style="list-style-type: none"> 14. TK Item 23- 1/2 Street Tee 15. TK Item 24- 1/4 Street Tee 16. TK Item 25- 1/8 Street Tee 17. TK Item 26- 1/4 Street Elbow 18. TK Item 27- 1/8 Street Elbow 19. TK Item 28- Inverted Flare Tee 20. TK Item 29- Connector Adapter 21. TK Item 30- Ignition Adapter 22. TK Item 31- Adapter, Tachometer Drive 23. TK Item 32- Fuel Line Adapter 24. TK Item 33- Air Chuck 25. TK Item 34- Pulse Tachometer 26. TK Item 35- Flexible Hose Assembly 27. TK Item 36- Long Hex Pipe Nipple |
|--|--|

TA356998

Figure 2-23. Transducer Kit.

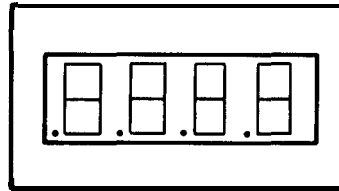
STE/ICE Instructions (Cent)

(1) *Pressure Transducers.* The pressure transducers have a small breather hole on the side of the housing which should be kept unplugged. Do not use high pressure shop air to blow out the 25 psig transducer.

(2) *Pulse Tachometer.* Make sure that the slotted hole in the engine tachometer drive shaft is clear and not hard packed with lubricant before installing the pulse tachometer.

(3) *Threaded Adapters.* Look at threaded fittings carefully to avoid engaging straight threads with pipe threads. Each measurement device (transducer) in the transducer kit has its own identification resistor. The VTM uses this identification resistor to check that the correct transducer is connected for the measurement being made. If the correct transducer is not connected, error code EO02 will be displayed.

i. Types of Readouts. The following paragraphs describe and show the different types of readouts that can occur during testing.



TA356837

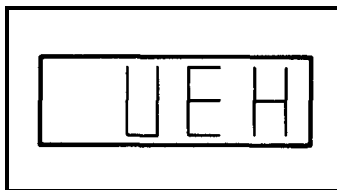
(1) *Status Readout.* A status readout keeps the operator informed of what is happening. For example, .8.8.8.8 is displayed each time the power switch is pushed on. It means that power is applied, and that all elements of the display are operative. It changes to ---- 1.5 seconds later, indicating that the VTM is ready to be used for testing. The status readout displays are described in Table 2-12.

Table 2-12. Status Readout

| VTM Readout | Interpretation |
|--------------|---|
| .8.8.8.8 | A readout of .8.8.8.8 appears for 1 to 2 seconds each time that the power is applied to the VTM. It means that there is power to the VTM, and that all elements of the readout display are operative. |
| ---- | A readout of ---- indicates the following: (1) After power turn-on, signifies that the VTM is ready for testing. (2) During a compression unbalance test, signifies testing is in progress. |
| .9.9.9.9 | A readout of .9.9.9.9 indicates that the VTM is reading a test value beyond the range of its measurement capability. Either the wrong test number is selected for the parameter being measured, or there is a fault in the vehicle. |
| PASS FAIL | A PASS or FAIL readout is the result of a test that checks the condition of a component being measured. A PASS/FAIL readout means just that - the component either passes the test or fails the test. |

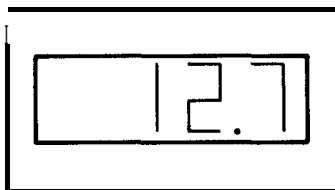
STE/ICE Instructions (Cont)

2-16. SIMPLIFIED TEST EQUIPMENT FOR INTERNAL COMBUSTION ENGINES (STE/ICE) INTRODUCTION (CONT).



TA35683

(2) *Prompting Message.* A prompting message is an operator action message. It is a signal to do something, such as crank the engine. UEH, for example, is the prompt to enter the vehicle type identification number into the VTM. After the operator action is performed, the test will automatically continue. Prompting messages are listed in Table 2-13.



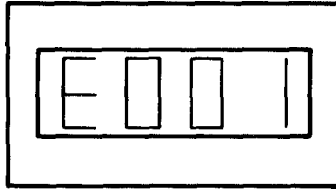
TA35683

(3) *Numerical Readout.* A numerical readout is the measured value in units of the measurement being made. For example, if measuring 0-45 volts DC, 12.7 is volts DC. If measuring 0-25 PSIG pressure, 12.7 is PSIG. The units for each test are listed on the flip cards. The numbers displayed on the VTM are always positive unless there is a minus shown to make them negative.

Table 2-13. Prompting Messages

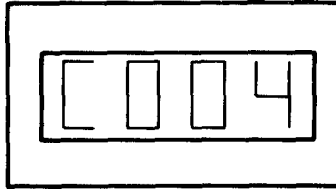
| VTM Readout | Interpretation |
|-------------|--|
| UEH | Signal to operator to enter vehicle type identification number (VID) on the test SELECT switches. Vehicle ID numbers are found under TEST DATA on the flip cards, on the vehicle test cards, or GO1 of the appropriate GO Chain in this manual. M977 series vehicle VID is 18. |
| CYL | Signal to operator to enter number of CYLinders or cylinder pairs on the TEST SELECT switches. These numbers are found under TEST DATA on the flip cards. |
| GO | Signal to operator to crank engine in compression balance or first peak tests. |
| CIP | Signal to operator to apply full throttle in a CI power test. |
| OFF | Signal to operator to stop cranking in compression balance test or to release the accelerator in the CI power test. |
| CAL | Signal to the operator to release the TEST button during an offset test. |
| 66 | Numbers are used for prompting messages in several tests. They are as follows; in confidence test 66, signals the operator to dial in 99. In CI acceleration/deceleration power test No. 12, the first numerical readout signals the operator to shut off fuel. |

STE/ICE Instructions (Cont)



TA356833

(4) *Error Readout.* E001 is a typical error readout. There are 17 different error readouts, all starting with E. An error readout warns that the transducer was not connected, wrong test number was entered, engine failed to start, etc. All of the error messages mean the problem must be corrected before continuing testing. The error messages are described in Table 2-14. If an error message does not go away after corrective action, refer to TM 9-4910-571-12&P for error message fault isolation.



TA356834

(5) *Confidence Error Readouts.* C004 is a typical confidence error readout resulting from the detection of a faulty VTM during confidence test. There are 44 of these codes. They are used by the DS Repairman as an aid in repairing a faulty VTM.

STE/ICE Instructions (Cent)**2-1 6. SIMPLIFIED TEST EQUIPMENT FOR INTERNAL COMBUSTION ENGINES (STE/ICE) INTRODUCTION (CONT).****Table 2-14.** Error Readouts

| VTM Readout | Interpretation |
|-------------|---|
| E000 | Occurs if requesting the VTM for information it does not have. For example, if requesting the vehicle ID and it has not been entered. |
| E001 | Occurs in either the DCA or TK modes of operation. It indicates that a nonexistent test number has been dialed into the TEST SELECT switches. |
| E002 | Indicates that the required transducer is not connected. |
| E003 | Indicates that a test number has been dialed which does not apply to the vehicle under test. It can only occur in DCA mode. |
| E004 | Indicates that a vehicle identification number or number of cylinders information has not been entered. |
| E005 | Indicates that the transducer offset test was not performed. |
| E007 | Indicates a conflict between the vehicle identification number (VID) dialed in and the number of cylinders dialed in. It may occur in response to either entry. |
| E008 | Indicates the VTM is not receiving the required voltage signal for the test selected. The error code is related only to starter and compression balance tests. |
| E009 | Indicates that the engine was not running at the start of the test. |
| E010 | Indicates that a wrong vehicle identification number was dialed into the VTM. |
| E011 | Indicates that the throttle control was operated incorrectly during power test taking too much time to either accelerate or decelerate. |
| E012 | Indicates that the S1 ignition adapter or the CI pulse tachometer is missing. (Not applicable to M977 series vehicles). |
| E013 | Indicates bad data was taken for the test in progress. Repeat the test one (1) time. |
| E014 | Indicates that a wrong number of cylinders was dialed into the VTM. |
| E015 | Indicates that the numbers of cylinders dialed into the VTM in the DCA mode conflicts with the number of cylinders in the vehicle, (Not applicable to M977 series vehicles). |
| E017 | Indicates that the engine is not running or that the ignition adapter is broken or not properly connected. |
| E018 | Indicates that an engine RPM or AC frequency test was terminated automatically to protect the VTM. Termination is only after several minutes of non-signal operation. Most likely the VTM was left on the vehicle and the engine stalled. |

STE/ICE Instructions (Cent)

i. operating Modes. The two basic modes in which the STE/ICE system is operated are the Diagnostic Connector Assembly (DCA) mode, and the Transducer Kit (TK) mode. The DCA and TK can also be operated together in a combined mode.

(1) *DCA Mode.* In the DCA mode, the VTM is connected to a diagnostic connector assembly installed in the vehicle. The diagnostic connector, which is located in the cab, terminates a wiring harness routed throughout the vehicle. The wires in the harness connect to test points on the vehicle and also to the vehicle's battery system. The connector and harness are a permanent part of the vehicle.

(2) *TK Mode.* In the TK mode, the VTM is connected to the vehicle using adapters, transducers, and cable assemblies contained in the Transducer Kit. The transducers are installed in place to make the tests and are removed when testing is completed. One or more cables are required to connect the required points and supply power to the VTM.

(3) *Combined Mode.* The DCA and the TK can be used at the same time. This may be necessary when the diagnostic connector assembly has a missing transducer. If a transducer is missing, a no sensor indication (E002) is displayed when a measurement is made. If this happens, the TK mode can be used to make the measurement.

k. Vehicle Testing. The STE/ICE system was developed as a tool for the mechanic to use in testing both electrical and mechanical components on vehicles.

(1) *Data Entry Tests.* At the beginning of testing it is necessary for the operator to enter vehicle information into the VTM. The Vehicle Test Card will tell what data is required. The reason for entering data is that certain tests require vehicle or cylinder information to be done properly. Tests 13, 14, and 15 require VID information. If the VID is entered, the number of cylinders is automatically entered.

(a) *Cylinder Entry (Test 58).* In this test, the number of cylinders or number of cylinder parts is entered. If the operator does not know what number to enter, it can be found on the VTC or the flip card on the VTM. The VTM's response to test 58 is display CYL. This is the signal to dial the number of cylinders into the TEST SELECT switches and press the TEST button. The VTM will not try to perform a test, it just remembers the number of cylinders. If there is a problem with the number that was entered, one of the following error messages will be displayed: E007, E010, E014, or E015. These messages are described in Table 2-13.

(b) *Vehicle ID Entry (Test 60).* In this test the Vehicle identification number is entered. This number is given on the VTC and, for the M977 series vehicles, is number 18. The VTM's response to test 60 is to display UEE. This is the signal to dial the VID number (18) into the TEST SELECT switches and press the TEST button. The VTM will not try to perform a test, it just remembers the VID. If there is a problem with the number entered, error message E007 or E010 will be displayed. These messages are described in Table 2-14.

(2) *Data Display Tests (Tests 59, 61-64).* These tests are used to read out data previously stored in the VTM. Test 59 displays currently stored cylinder information when the TEST button is pressed. Test 61 displays the currently stored Vehicle ID number when the TEST button is pressed. Test 62 displays the currently attached DCA ID number when the TEST button is pressed (06 for M977 series vehicles). Test 63 displays the ID of the currently attached transducer on connector J2. Test 64 displays the ID of the currently attached transducer on connector J3. Refer to Table 2-15 for transducer ID numbers.

Table 2-15. Transducer ID Numbers

| Transducer attached to J2 or J3 | ID number displayed by test 63 or 64 |
|--|--------------------------------------|
| Pressure transducer -15 to +25 PSIG (red stripe) | 4 |
| Pressure transducer 0-1000 PSIG (blue stripe) | 7 |
| Pulse tachometer | 10 |
| Current Probe | 13 |

STE/ICE Instructions (Cent)

2-16. SIMPLIFIED TEST EQUIPMENT FOR INTERNAL COMBUSTION ENGINES (STE/ICE)
INTRODUCTION (CONT).

(3) *Offset Tests.* The STE/ICE VTM is made to perform a test by setting the TEST SELECT switches to the test number and pressing the TEST button. For some tests, an offset test is required before the test itself can be performed. This is done by selecting the number of desired test and holding the TEST button down until the VTM displays the prompting message CAL.

The offset test cancels characteristic differences in the VTM, test leads, and transducers. It zeros the meter. Once the offset test is performed, the VTM automatically corrects for the offset before displaying measured values. The displayed offset value should be checked against limits on the Vehicle Test Card. If the displayed value is outside these limits, either the transducer or the test cable is faulty and must be replaced. This is another form of self-test. Offset tests are done in both the DCA and TK modes of operation. At the beginning of the DCA mode, all offset test numbers are dialed into the VTM. In the TK mode, the offset is performed when each transducer is connected. All tests requiring offset are identified by a star(*) on the flip cards and by OFFSET LIMITS on the Vehicle Test Cards. The offset test is performed with the test probe cable or transducer connected to the VTM. Care should be taken that no stimulus is being applied to the transducer. Test probe cable leads should be shorted together. To perform an offset test, dial the test number into TEST SELECT. Press and hold TEST button until the prompting message CAL appears on the display. In a few seconds after release of TEST button, a number will appear. This is the measured offset value associated with the test probe cable or transducer or transducer and cable.

(4) *Control Tests.* These tests are used to change (or control) the way a vehicle testis displayed, or the way it is run. There are five (5) control tests.

01 Interleave (alternates RPM with next test measurement)

02 Display minimum value for next test

03 Display maximum value for next test

04 Display peak-to-peak value for next test

05 Initiate S1 full power simulation (Not applicable to M977 series vehicles).

Control tests 01, 02, 03, and 04 specify the action to be taken by the next test only. Any test dialed in after the test that is being controlled will cancel the effect of the test.

(a) *Interleave (Test 01).* This test alternately measures engine speed and a second parameter such as fuel pressure or alternator voltage. To start interleave, dial 01 into the Test SELECT switches and press the TEST button. The prompting message PASS will signal the operator to dial in the second test number and again press the TEST button.

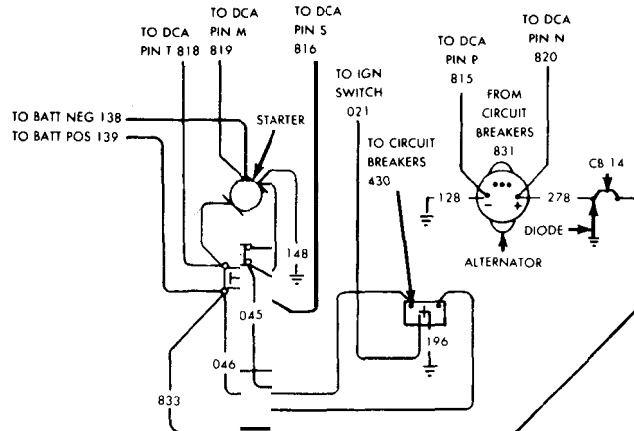
(b) *Minimum Value (Test 02).* This test displays the minimum value measured during a test. To start a minimum value display, dial 02 into the TEST SELECT switches and press the TEST button. The prompting message PASS will signal the operator to dial in the desired test number and again press the TEST button. The minimum value is displayed and updated whenever a lower minimum value is measured. Entering 02 and the test number again will reset the process and a new minimum value will be displayed.

(c) *Maximum Value (Test 03).* This test displays the maximum value measured during a test. To start a maximum value display, dial 03 into the TEST SELECT switches and press the TEST button. The prompting message PASS will signal the operator to dial in the desired test number and again press the TEST button. The maximum value is displayed and updated whenever a higher maximum value is measured. Entering 03 and the test number again will reset the process and a new maximum value will be displayed.

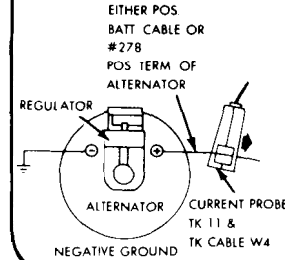
(d) *Peak-to-Peak Value (Test 04).* This test displays the peak-to-peak value of alt/gen output volts (82), 45-volts DC (89), 1500 amps DC (90), and battery volts (67). Electrical peak-to-peak is for measuring dwell variation. To start a peak-to-peak measurement, dial 04 into the TEST SELECT switches and press the TEST button. The prompting message PASS will signal the operator to dial in one of the four test numbers (82, 89, 90, 67) and again press the TEST button.

HEMTT - M977 - M985 VEHICLE TEST CARD - VID 18 - DCA

STARTING/CHARGING CIRCUIT DIAGRAM



ALTERNATOR TESTS



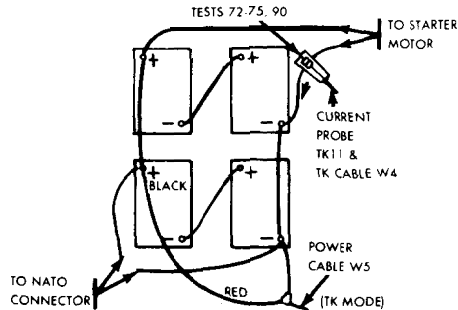
TEST 90, OUTPUT CURRENT, 40 AMPS MIN @ FAST IDLE (ACCESSORIES ON AND PARTIALLY DISCHARGED BATTERIES)

TEST 67, OUTPUT VOLTAGE, MEASURED AT SLAVE

VOLTS @ FAST IDLE (ACCESSORIES ON AND PARTIALLY DISCHARGED BATTERIES)

TRANSUCER BATTERY TESTS

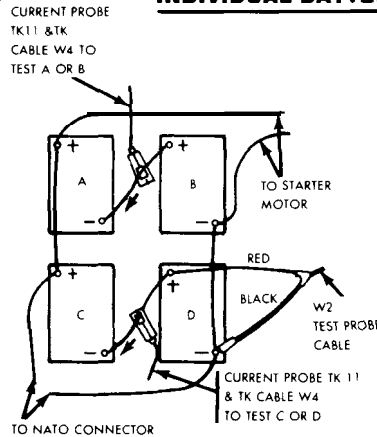
BATTERY PACK/CABLE TESTS



RIGHT SIDE OF VEHICLE WITH POWER CABLE AND CURRENT PROBE

| TEST NAME | TEST NO | OFFSET LIMIT | OPERATING CONDITION | LIMITS | | | UNITS |
|------------------------------------|---------|--------------|---------------------|--------|---------|------|------------|
| | | | | MIN | NORM | MAX | |
| STARTER CURRENT | 72 | +/-225 | CRANK ON GO | 1200 | — | 1900 | AMPS |
| STARTING MOTOR CURRENT AVERAGE | 90 | +/-225 | CRANKING | — | 300-500 | — | AMPS |
| BATTERY RESISTANCE PER PAIR | 73 | +/-225 | CRANKING | — | — | 25 | MILLI-OHMS |
| STARTER CIRCUIT RESISTANCE | 74 | +/-225 | CRANKING | — | 3-22 | 25 | MILLI-OHMS |
| BATTERY RESISTANCE CHANGE PER PAIR | 75 | +/-225 | CRANKING | — | — | 50 | MILLI-OHMS |

INDIVIDUAL BATTERY TESTS

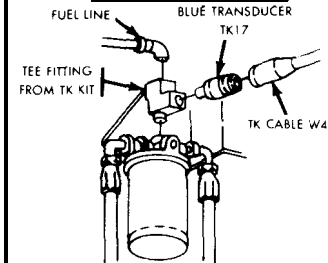


RIGHT SIDE OF VEHICLE TESTING INDIVIDUAL BATTERIES WITH TEST PROBE CABLE AND CURRENT PROBE

- TEST 78 STARTER CIRCUIT RESISTANCE, 25 MILLIOHMS, MAX
- TEST 90 AVERAGE CRANKING CURRENT, 200-450 AMPS
- TEST 77 INTERNAL BATTERY RESISTANCE, 13 MILLIOHMS, MAX, SINGLE BATTERY
- TEST 79 BATTERY RESISTANCE CHANGE 25 MILLIOHMS/SEC MAX, SINGLE BATTERY

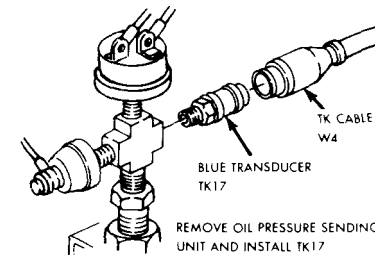
BATTERY TESTS ARE PERFORMED ON THE 4 BATTERIES AS A GROUP. IT MAY SOMETIMES BE NECESSARY TO ISOLATE TO A SINGLE BAD BATTERY. TO DO THIS THE TEST LEADS AND THE CURRENT PROBE ARE USED. THE TESTS LEADS ARE CONNECTED TO THE BATTERY UNDER TEST, THE CURRENT PROBE IS PLACED ON THE JUMPER BETWEEN THE PAIR OF BATTERIES THAT INCLUDES THE BATTERY UNDER TEST, THE DIAGRAM BELOW SHOWS THE CURRENT PROBE POSITIONS THE TEST LEADS ARE SHOWN IN POSITION TO TEST BATTERY D.

FUEL PRESSURE



FUEL PRESSURE, MEASURED AT INLET LINE TO SECONDARY FUEL FILTER 4 PSI MIN @ CRANKING 50-70 PSI @ HIGH IDLE 2100 RPM

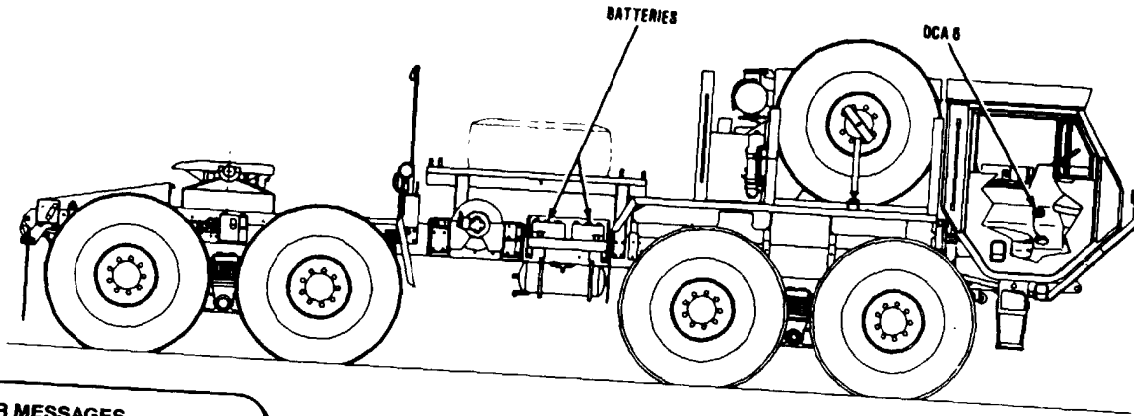
OIL PRESSURE



TEST 50, OIL PRESSURE, 5 PSI MIN @ IDLE 40-70 PSI @ HIGH IDLE 2100 RPM

STE/ICE Instructions (Cont)

HEMTT - M977 - M985 VEHICLE TEST CARD - VID 18 - DCA 6



ERROR MESSAGES

- E000 INFORMATION NOT AVAILABLE
- E001 TEST NON-EXISTENT
- E002 TRANSDUCER NOT CONNECTED
- E003 TEST NOT VALID IN THIS DCA
- E004 VID OR NUMBER OF CYL. NOT ENTERED
- E005 CAL NOT PERFORMED
- E007 NUMBER OF CYL. CONFLICTS WITH VID
- E008 TEST PROBE NOT CONNECTED
- E009 ENGINE NOT RUNNING
- E010 BAD VID
- E011 ACCEL/DECEL TIME TO LARGE
- E012 TACH PICKUP MISSING
- E013 BAD DATA
- E014 BAD NUMBER OF CYLINDERS
- E018 TEST DISCONTINUED, EXCESSIVE TIME
- 9.9.9.9 OVERLOAD OR NUMBER EXCEEDS DISPLAY CAPABILITY

OPERATOR MESSAGES

- PASS TEST SUCCESSFULLY COMPLETED
- CAL OFFSET TEST IN PROGRESS, RELEASE TEST BUTTON
- CIP INITIATE CI POWER SIMULATION
- CYL ENTER NUMBER OF CYLINDERS OR CYLINDER PAIRS
- FAIL TEST FAILED
- GO CRANK ENGINE
- OFF IF CRANKING STOP!
- IF CI POWER, DECELERATE!
- UEH ENTER VEHICLE IDENTIFICATION NUMBER
- ... VTM ACCEPTING DATA OR INITIAL TURN-ON
- 0066 DIAL 99, PUSH TEST BUTTON
- .8.8.8 CHECK DISPLAY

PRE-TEST INSPECTION

1. ACCESSORY DRIVE BELTS
2. OIL LEVEL
3. COOLANT LEVEL
4. FUEL LEVEL
5. BATTERIES

INITIAL ENTRY

- TEST 66 CONFIDENCE TEST (SECOND ENTRY - 99)
- TEST 60 VID ENTRY - 18
- TEST 61 VID DISPLAY
- TEST 62 DCA ID

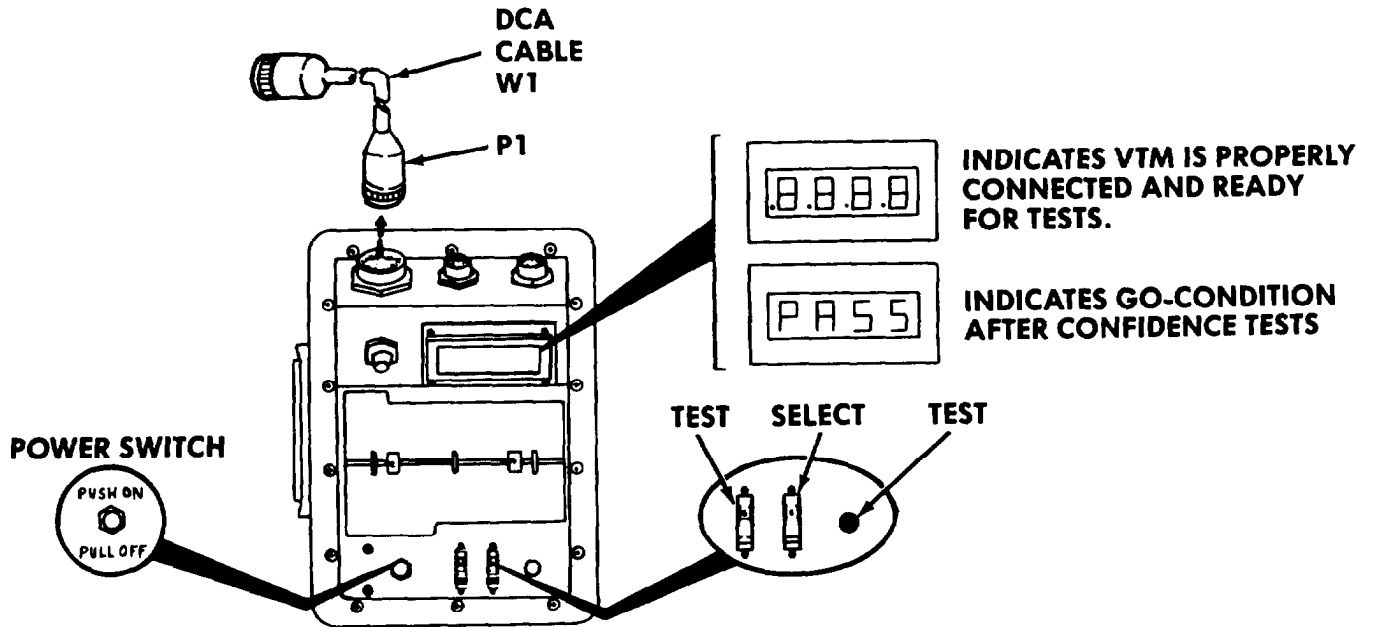
CONTROL OF NEXT TEST

- 01 INTERLEAVE WITH SPEED
- 02 DISPLAY MIN. VALUE
- 03 DISPLAY MAX. VALUE
- 04 DISPLAY PEAK-PEAK VALUE

| TEST NAME | TEST NO | OFFSET LIMIT | OPERATING CONDITION | LIMITS | | | UNITS |
|------------------------------|--------------|--------------|---|-------------|---------|-------------|----------------|
| | | | | MIN | NORM | MAX | |
| BATTERY VOLTAGE | 67 01. 67 | - | ENGINE OFF LIGHTS-ON 1000-1200 RPM | 22 26.5 | - 28 | - 29.5 | VOLTS VOLTS |
| ENGINE RPM | 10 10 | - | IDLE, NO LOAD GOVERNOR SPEED, NO LOAD | 600 2200 | - | 700 2300 | RPM RPM |
| FUEL FILTER RESTRICTION | 26 | - | GOVERNOR SPEED, NO LOAD | - | PASS | - | PASS/ FAIL |
| FUEL PUMP VOLTAGE | 27 | - | IDLE | 26.5 | - | 29.5 | VOLTS |
| ALTERNATOR VOLTAGE | 01. 82 | - | LIGHTS ON 1000-1200 RPM | 26.5 | - | 29.5 | VOLTS |
| ALTERNATOR NEG CABLE DROP | 01. 84 | - | 1000-1200 RPM | - | - | 0.5 | VOLTS |
| STARTER SOLENOID VOLTAGE | 70 | - | CRANKING | 18 | - | - | VOLTS |
| STARTER NEG CABLE DROP | 69 | - | CRANKING | - | - | 0.5 | VOLTS |
| STARTER POS TERMINAL VOLTAGE | 68 | - | CRANKING | 18 | - | - | VOLTS |
| ALTERNATOR OUTPUT VOLTAGE | 82 | - | 1000-1200 RPM | 26.5 | - | 29.5 | VOLTS |
| ALTERNATOR FIELD VOLTAGE | 83 | - | 1000-1200 RPM | - | - | 1.0 | VOLTS |
| ALTERNATOR NEG CABLE DROP | 84 | - | 1000-1200 RPM | - | - | 0.5 | VOLTS |

NOTE: TEST LIMITS GIVEN ARE ADVISORY ONLY AND ARE NOT NECESSARILY THE SAME AS MANUFACTURERS SPECIFICATIONS.

STE/ICE Go/No-Go Chain



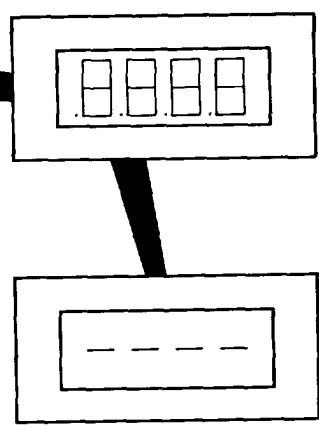
GO1 VTM CONNECTIONS AND CHECKOUT

CAUTION

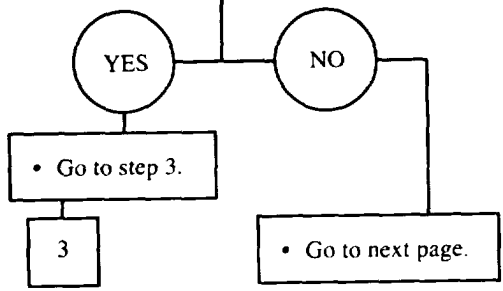
VTM or DCA cable can be damaged by electrical arcing. Do not connect or disconnect VTM while vehicle is running. Connect DCA cable to VTM before connecting to diagnostic connector.

1 CONNECT VTM TO VEHICLE DIAGNOSTIC CONNECTOR

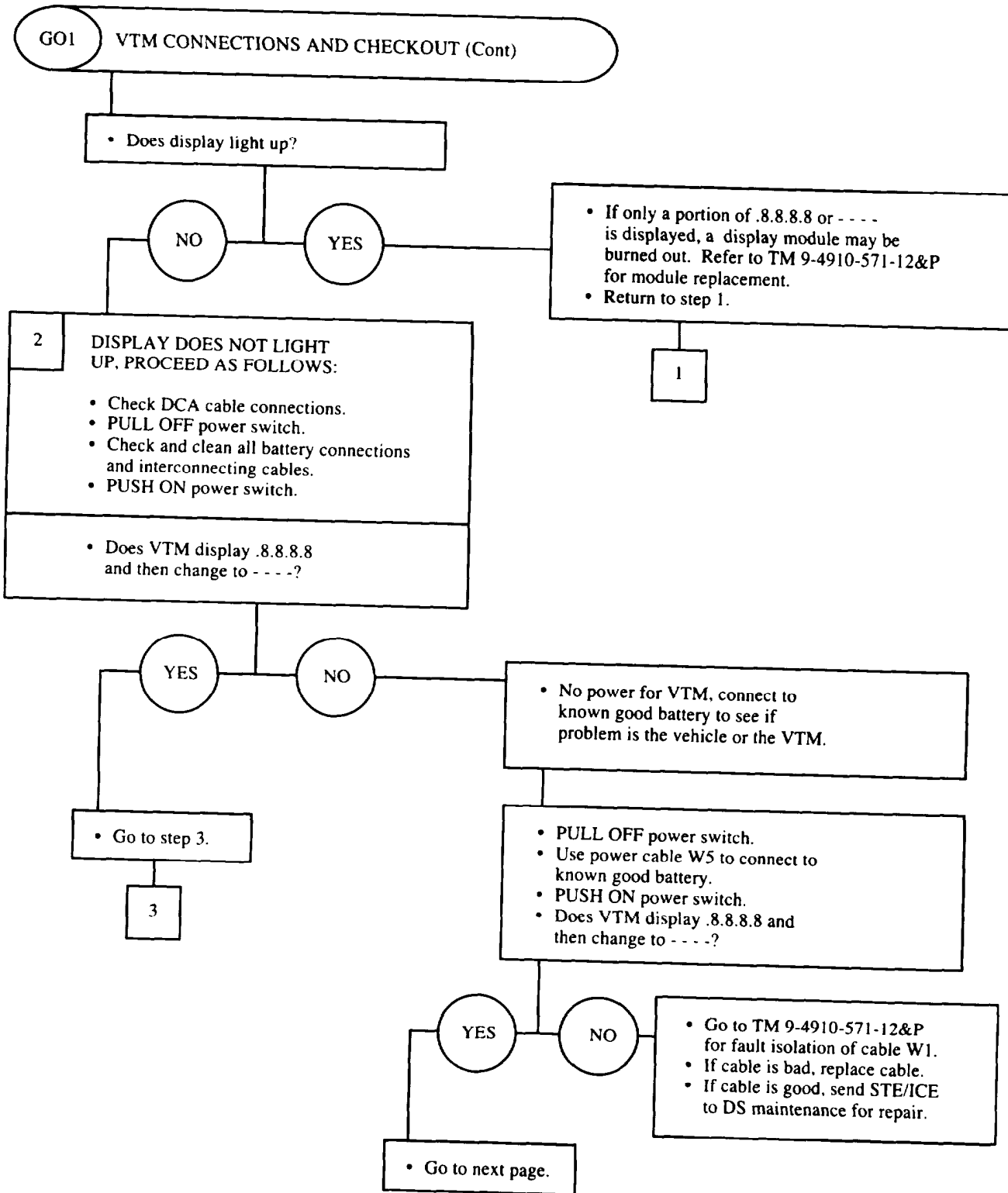
- PULL OFF VTM power switch.
- Connect DCA cable to VTM.
- Connect DCA cable to vehicle.
- PUSH ON VTM power switch.
- Check that display indicates .8.8.8.8 for approximately 2 seconds and then changes to ----?
- Does VTM display .8.8.8.8 and then change to ----?



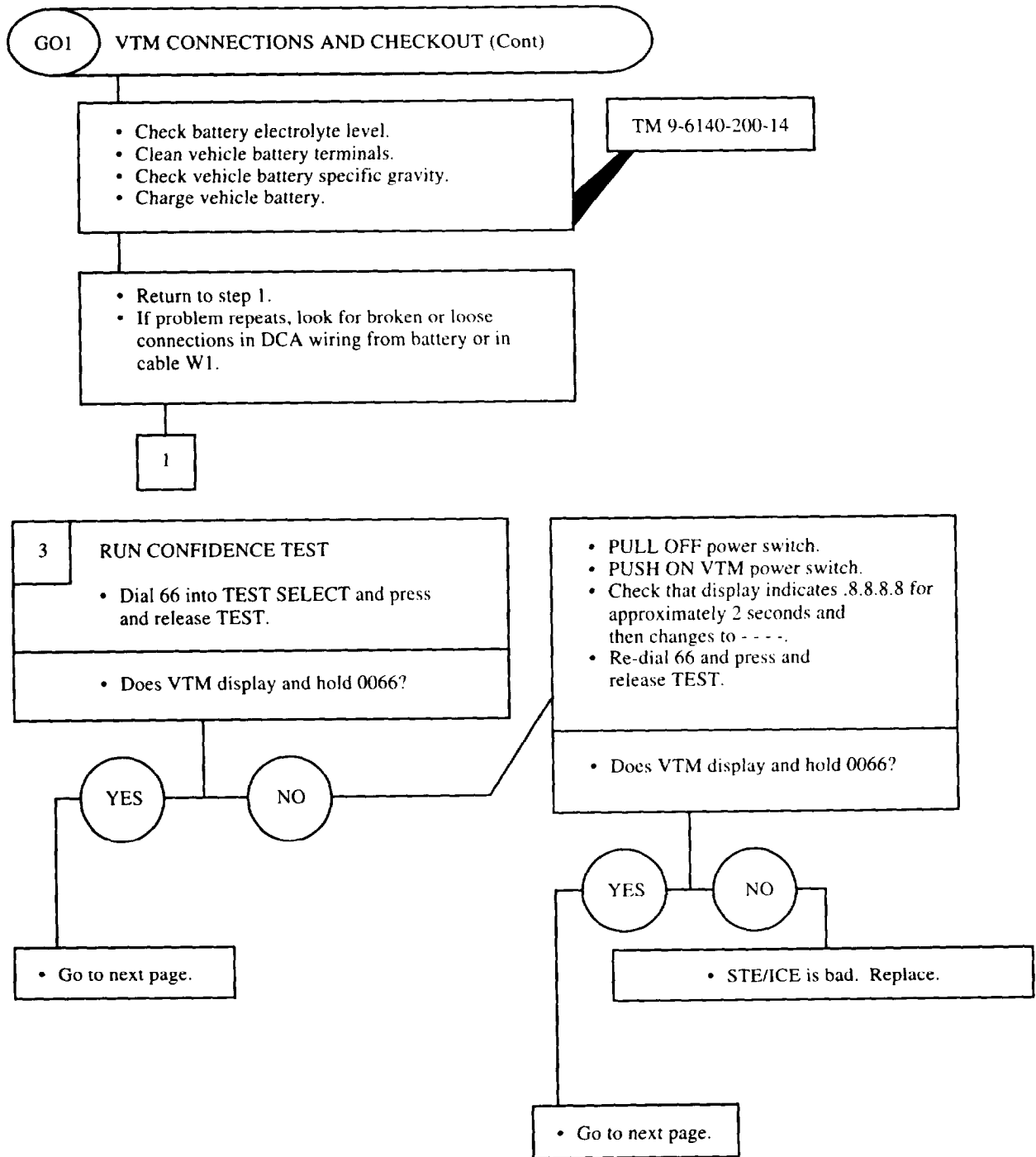
AFTER 2 SECONDS



STE/ICE Go/No-Go Chain (Cont)



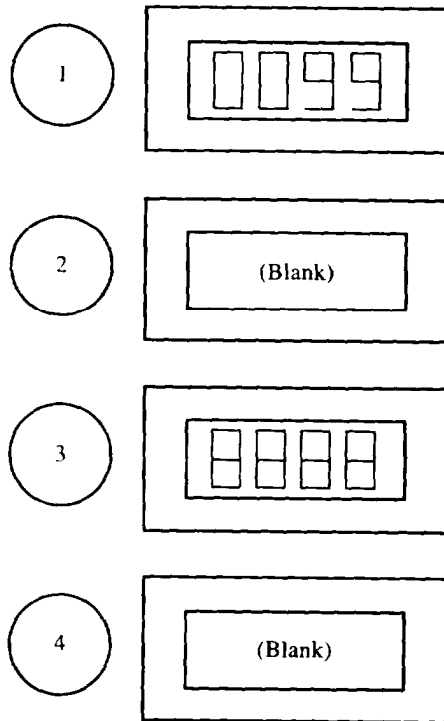
STE/ICE Go/No-Go Chain (Cont)



STE/ICE Go/No-Go Chain (Cont)

GO1 VTM CONNECTIONS AND CHECKOUT (Cont)

- Dial 99 into TEST SELECT and press and release TEST.
- Look for this display:

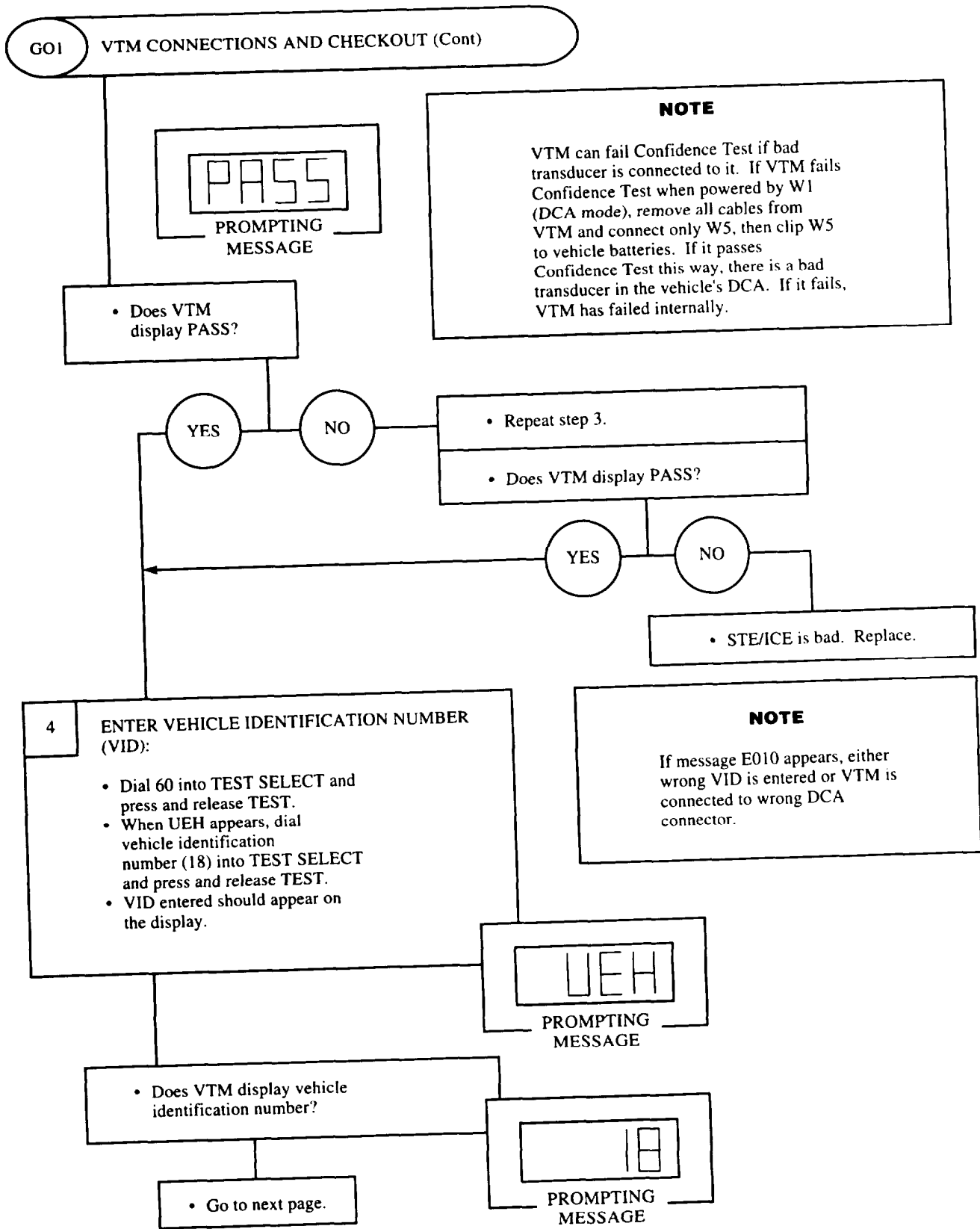


NOTE
At this point in test, several numbers will appear on display. Wait for readout display of PASS.

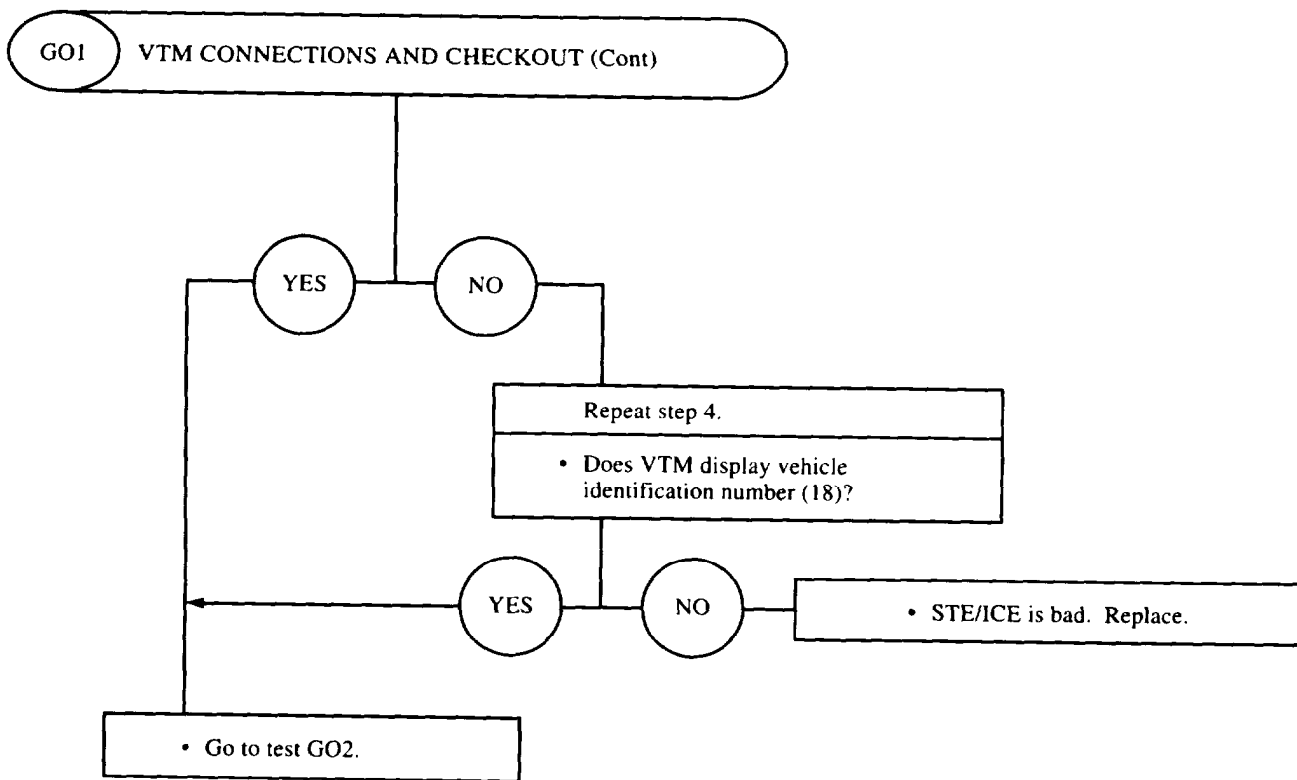
A rectangular display box containing the word 'PASS' in a digital font.

- Go to next page.

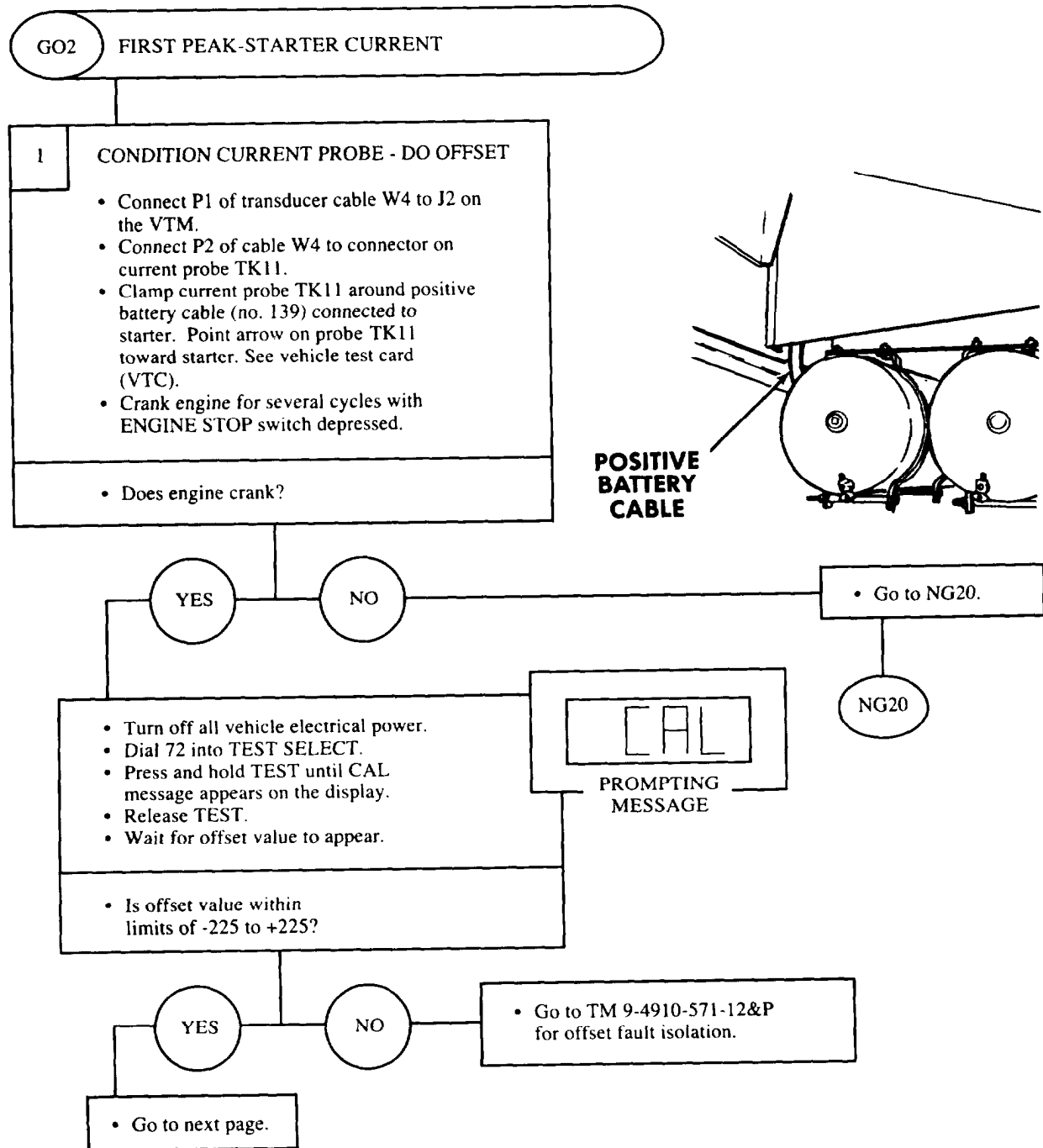
STE/ICE Go/No-Go Chain (Cont)



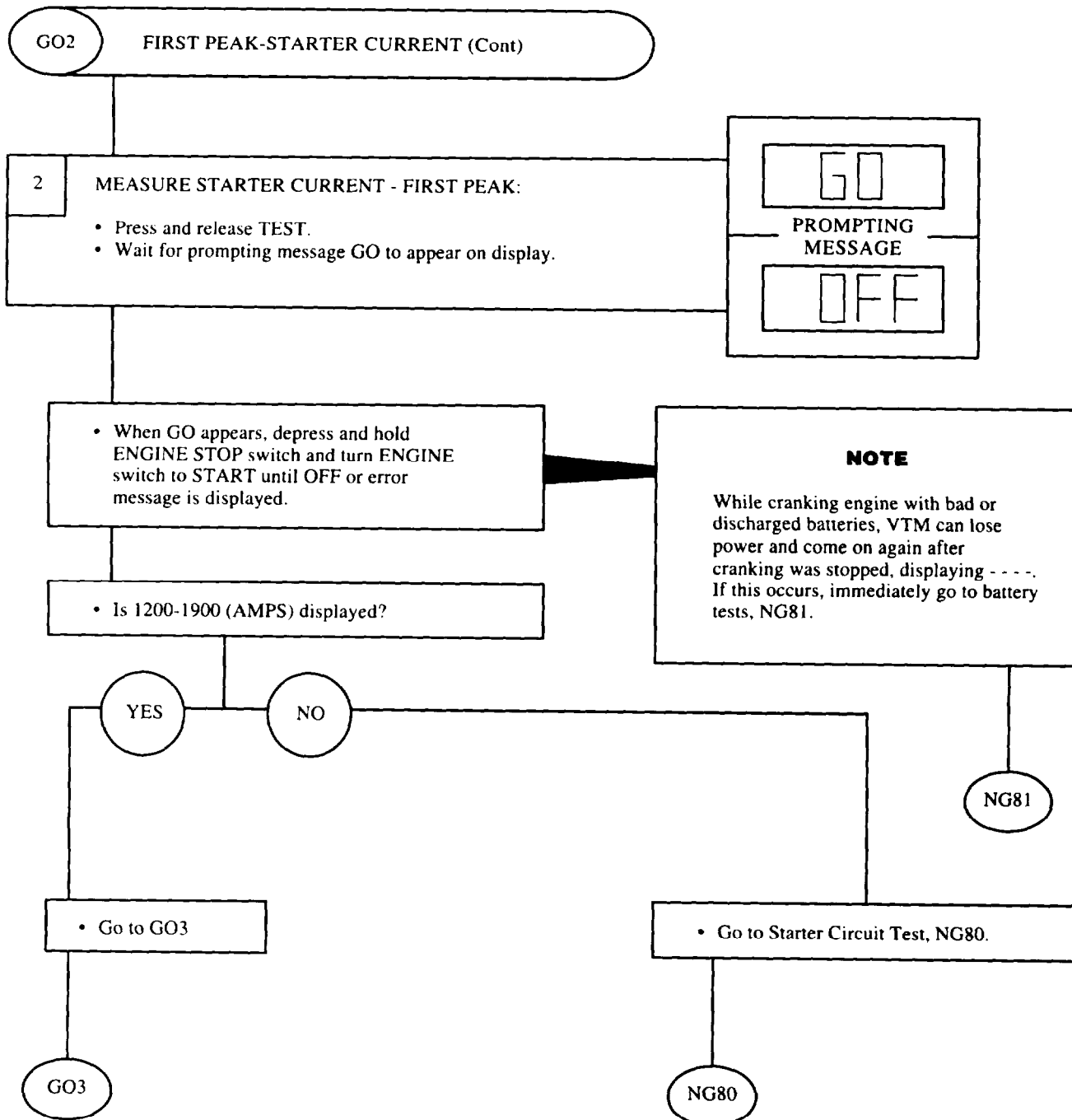
STE/ICE Go/No-Go Chain (Cont)



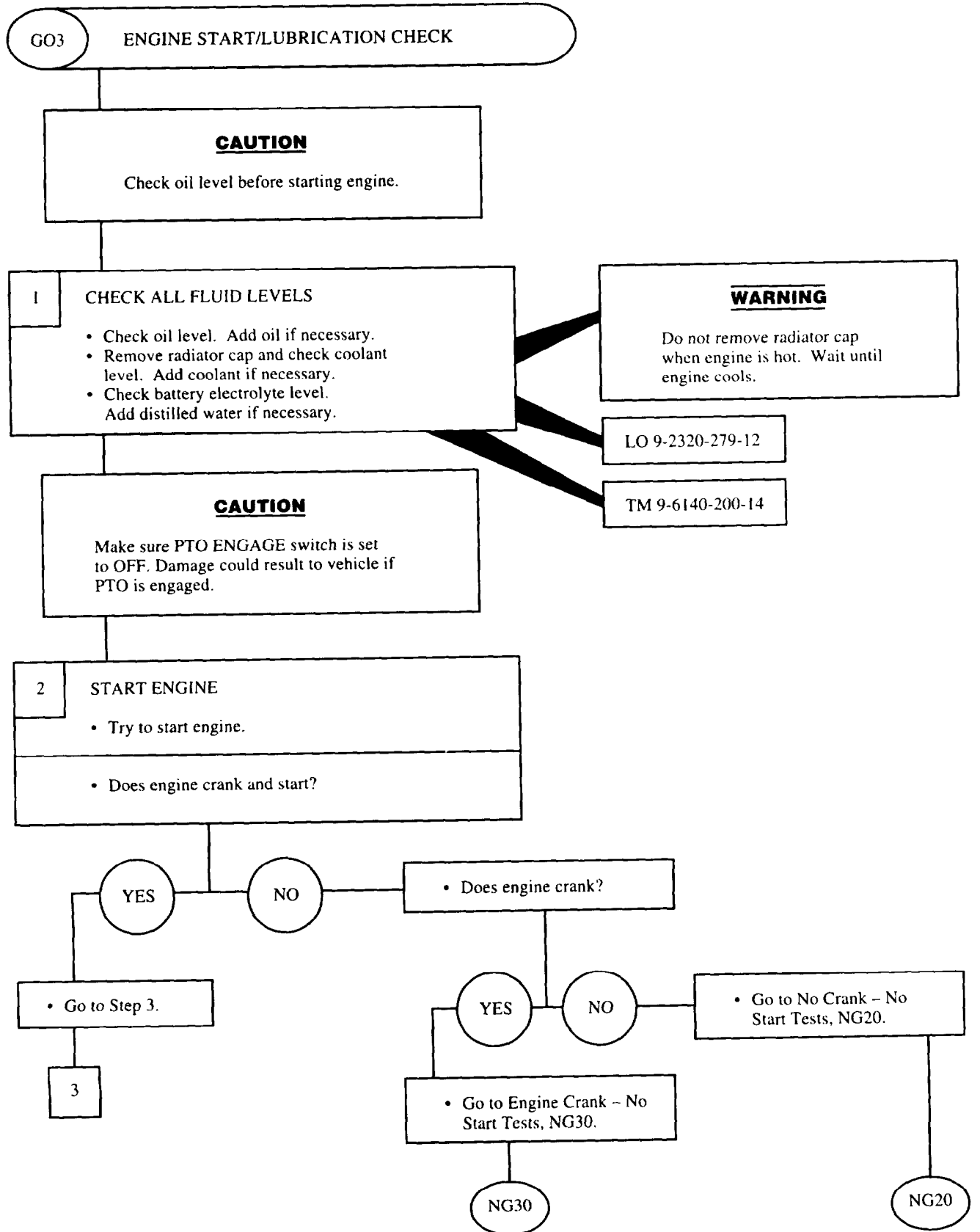
STE/ICE Go/No-Go Chain (Cont)



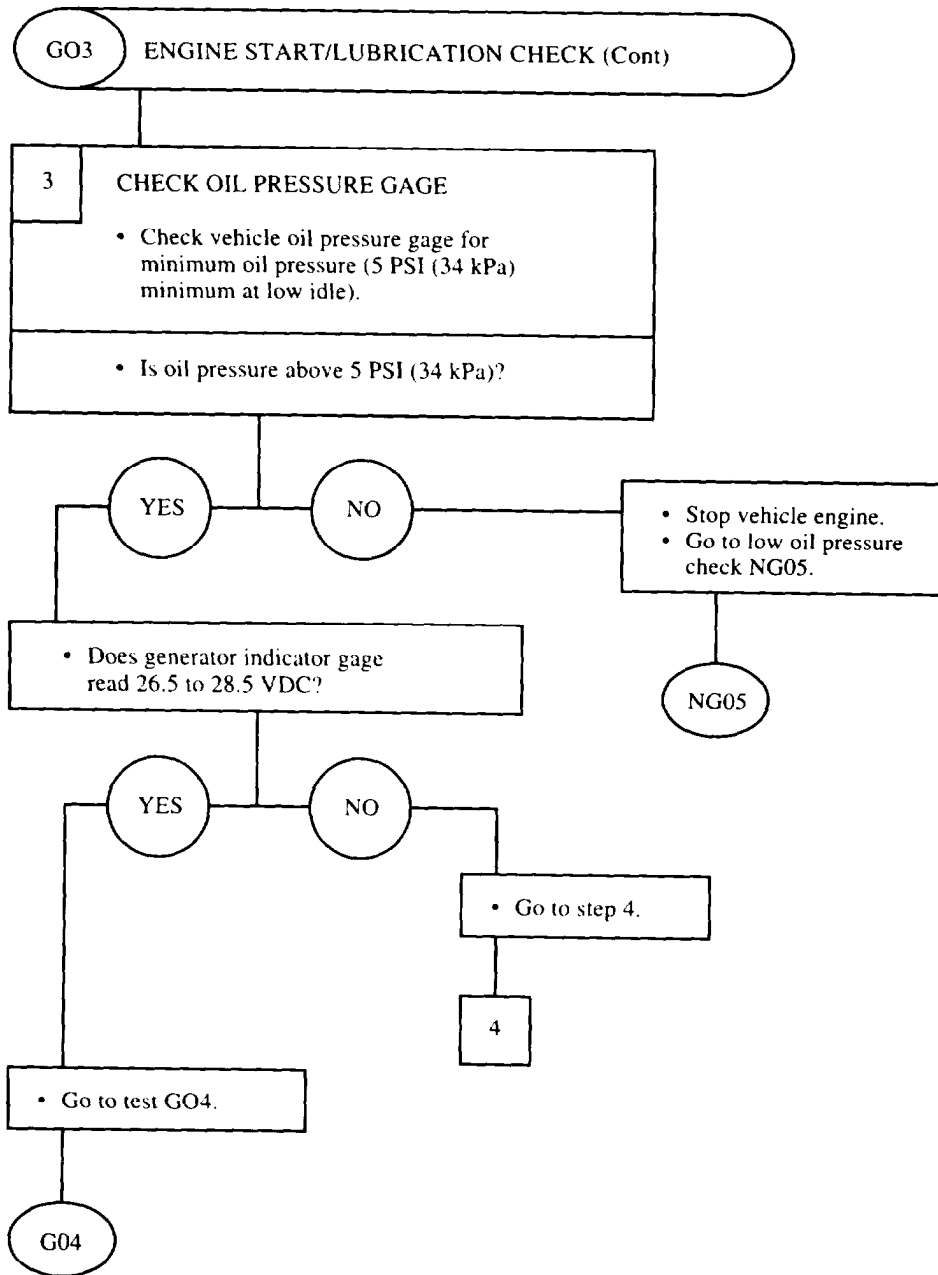
STE/ICE Go/No-Go Chain (Cont)



STE/ICE Go/No-Go Chain (Cont)



STE/ICE Go/No-Go Chain (Cont)



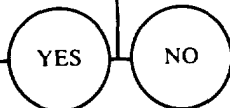
STE/ICE Go/Go/No-Go Chain (Cont)

G03 ENGINE START/LUBRICATION CHECK (Cont)

4 CHECK GAGES

- Check all other vehicle gages for normal readings.

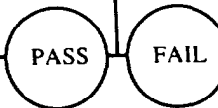
- Do all gages show normal readings?



5 CHECK RESISTOR MODULE

- Dial 10 into TEST SELECT and press TEST. Watch VTM for RPM display.
- Dial 26 into TEST SELECT and press TEST.
- Watch VTM for PASS/FAIL display.

- Did VTM display RPM's and then PASS or FAIL?

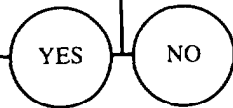


• Resistor module is bad. Refer to paragraph 7-93 and replace.

• Proceed to test G04.



• Did suspect gage stay at zero or immediately go to full scale when engine started?



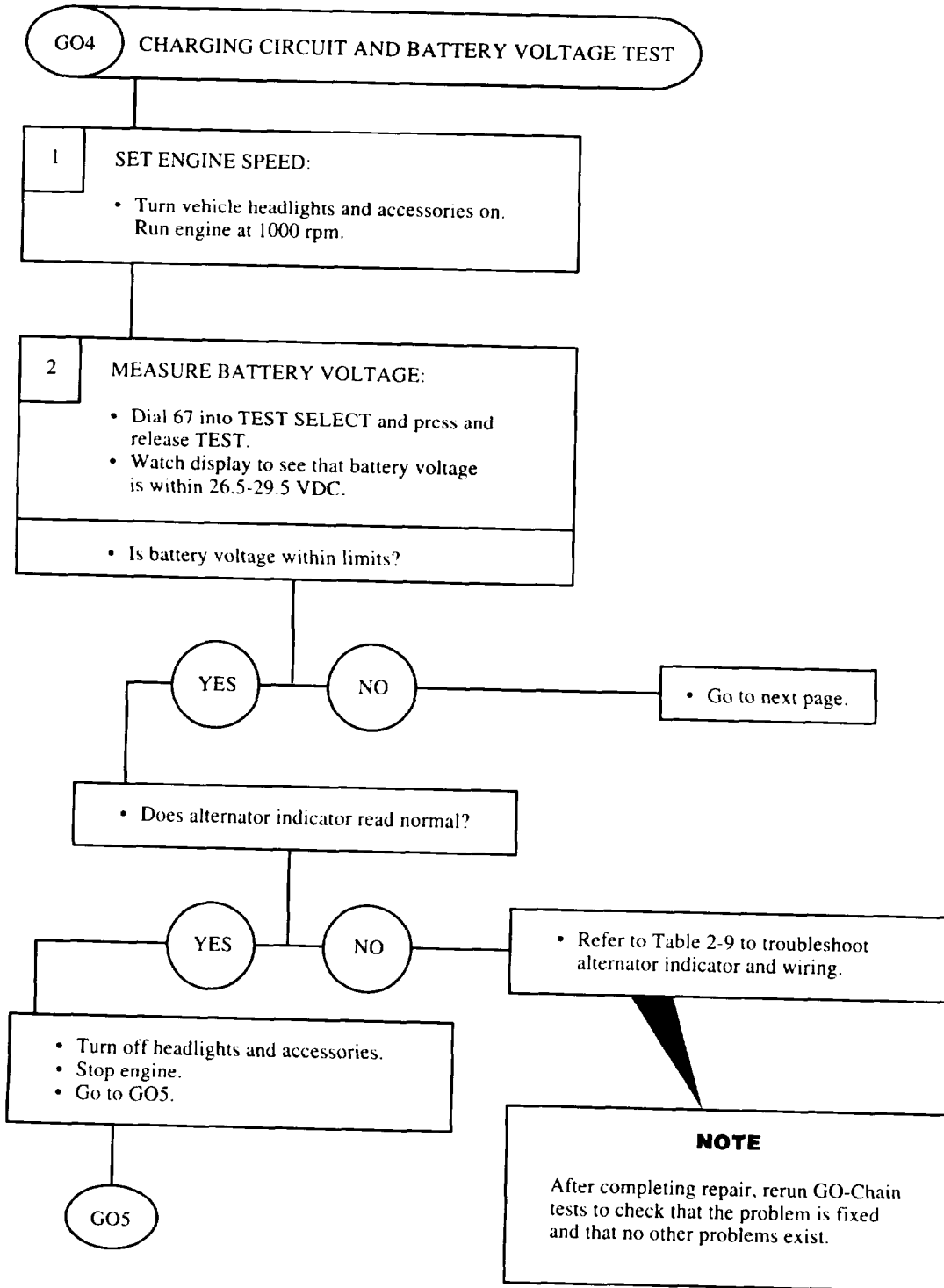
• Go to NG31 to troubleshoot gages.



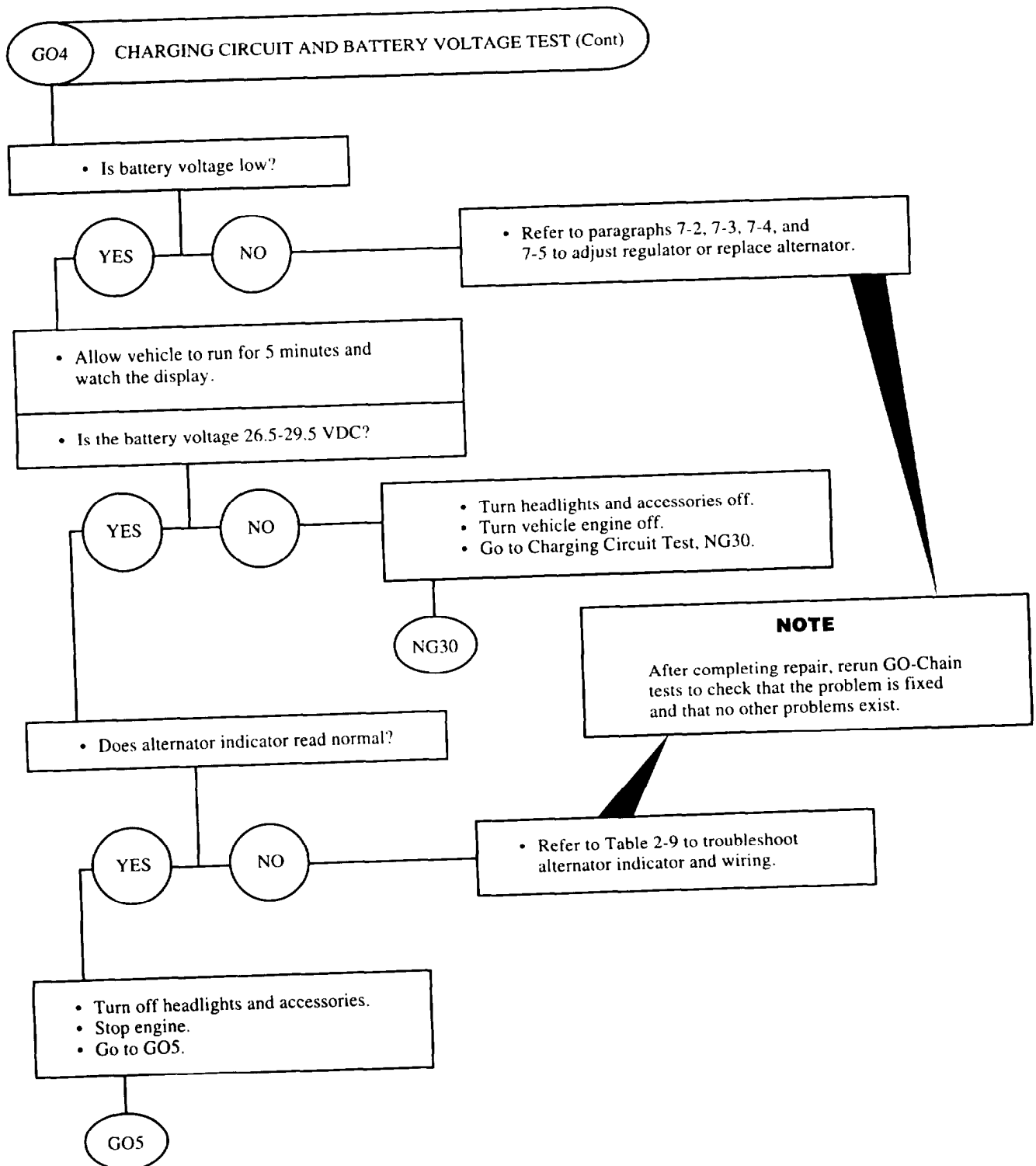
• Refer to Table 2-9 to locate and correct problem.

NOTE
After completing repair, rerun GO-Chain tests to check that the problem is fixed and that no other problems exist.

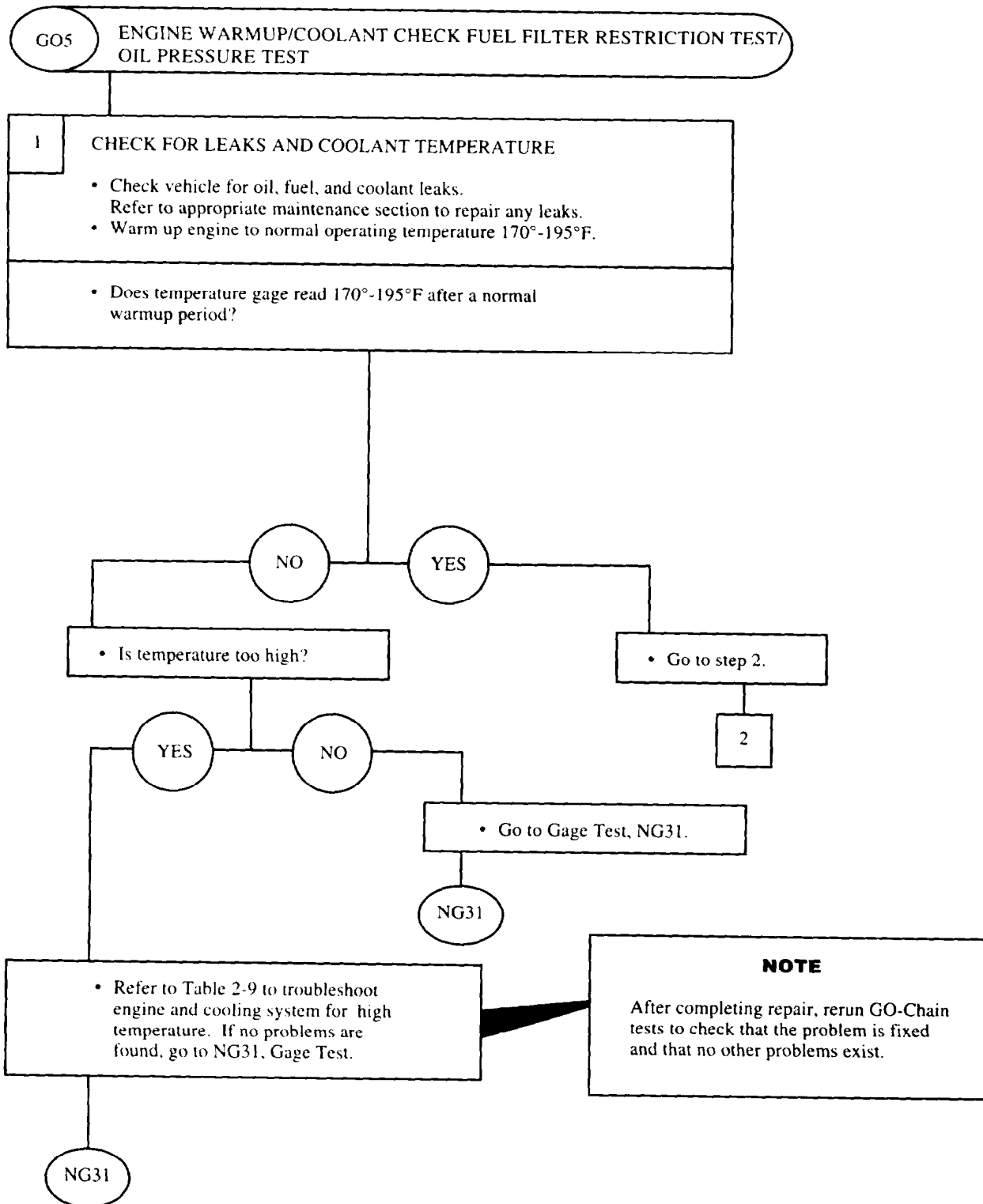
STE/ICE Go/No-Go Chain (Cont)



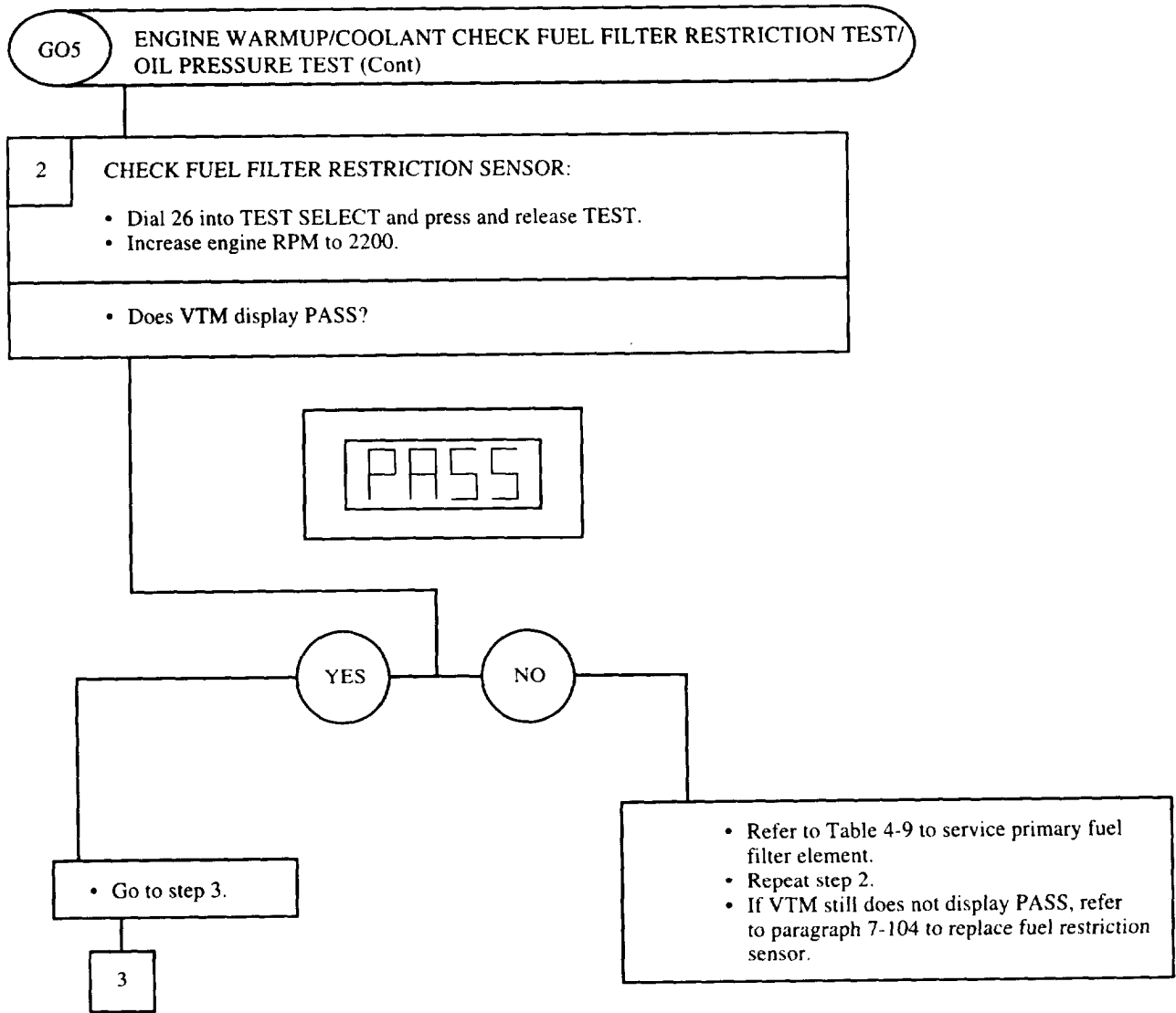
STE/ICE Go/No-Go Chain (Cont)



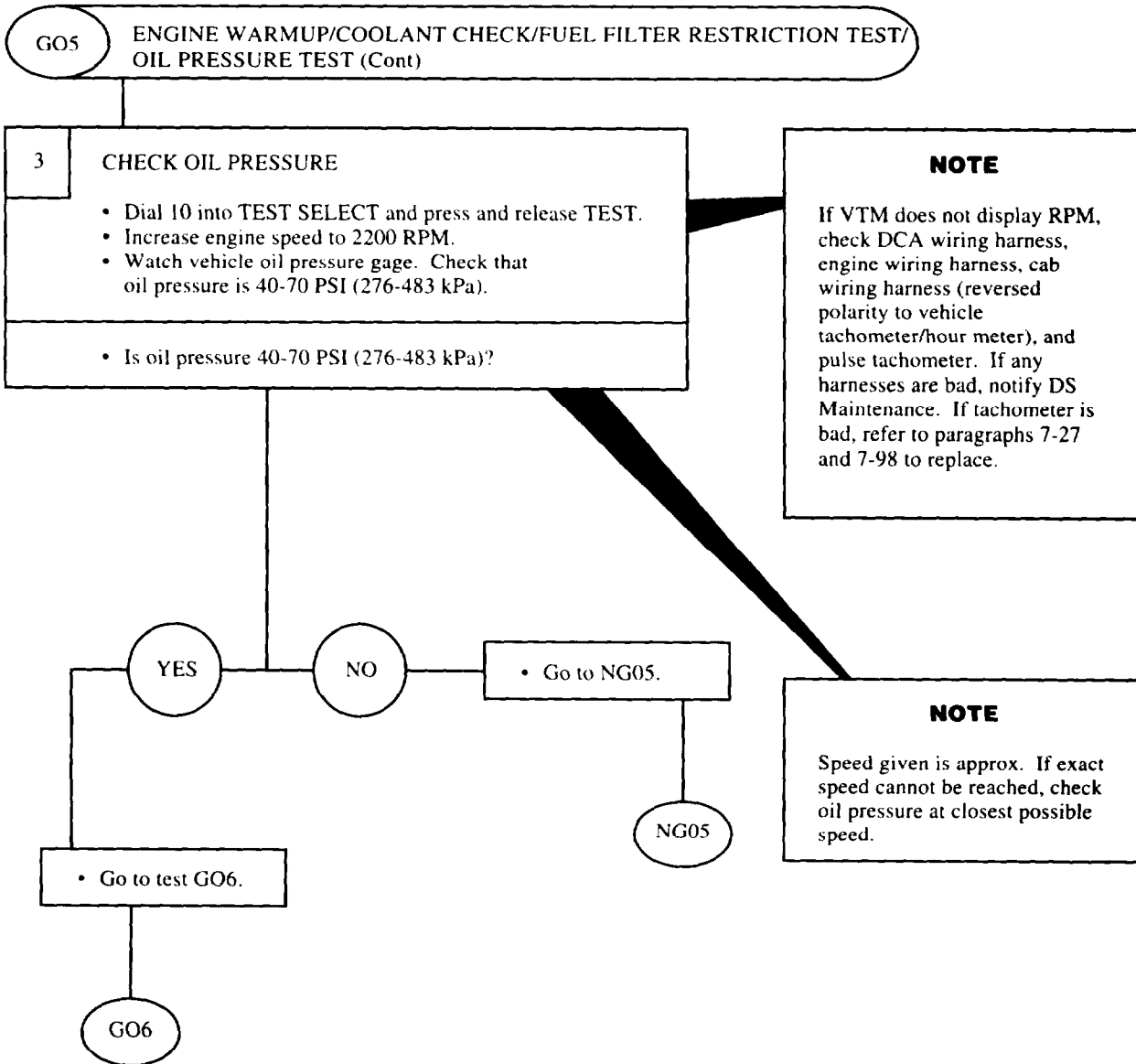
STE/ICE Go/No-Go Chain (Cont)



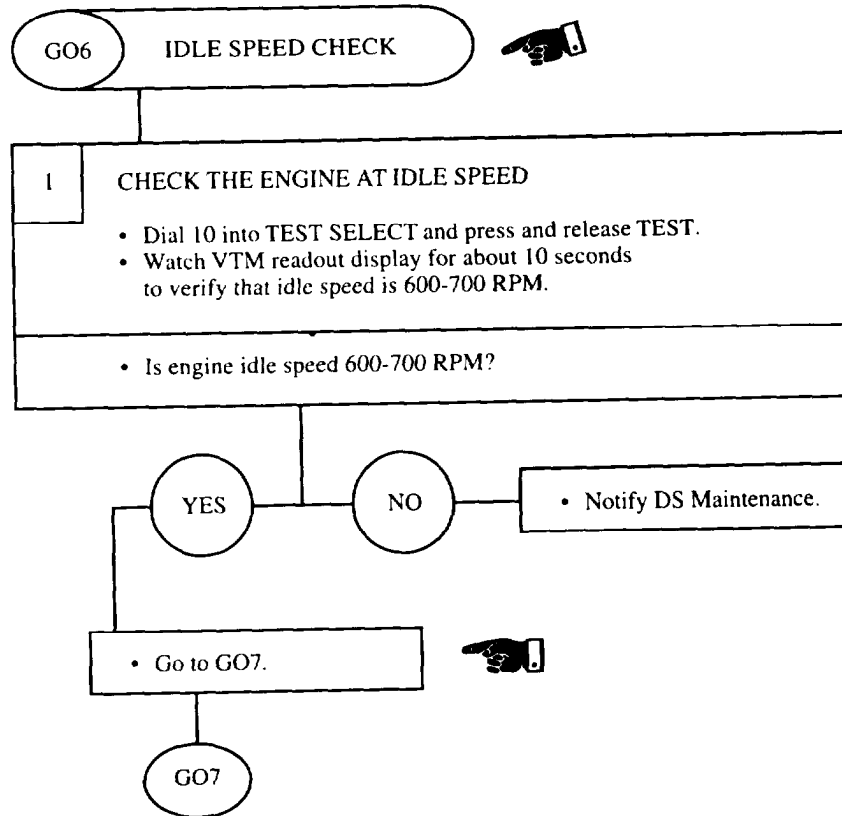
STE/ICE Go/No-Go Chain (Cont)



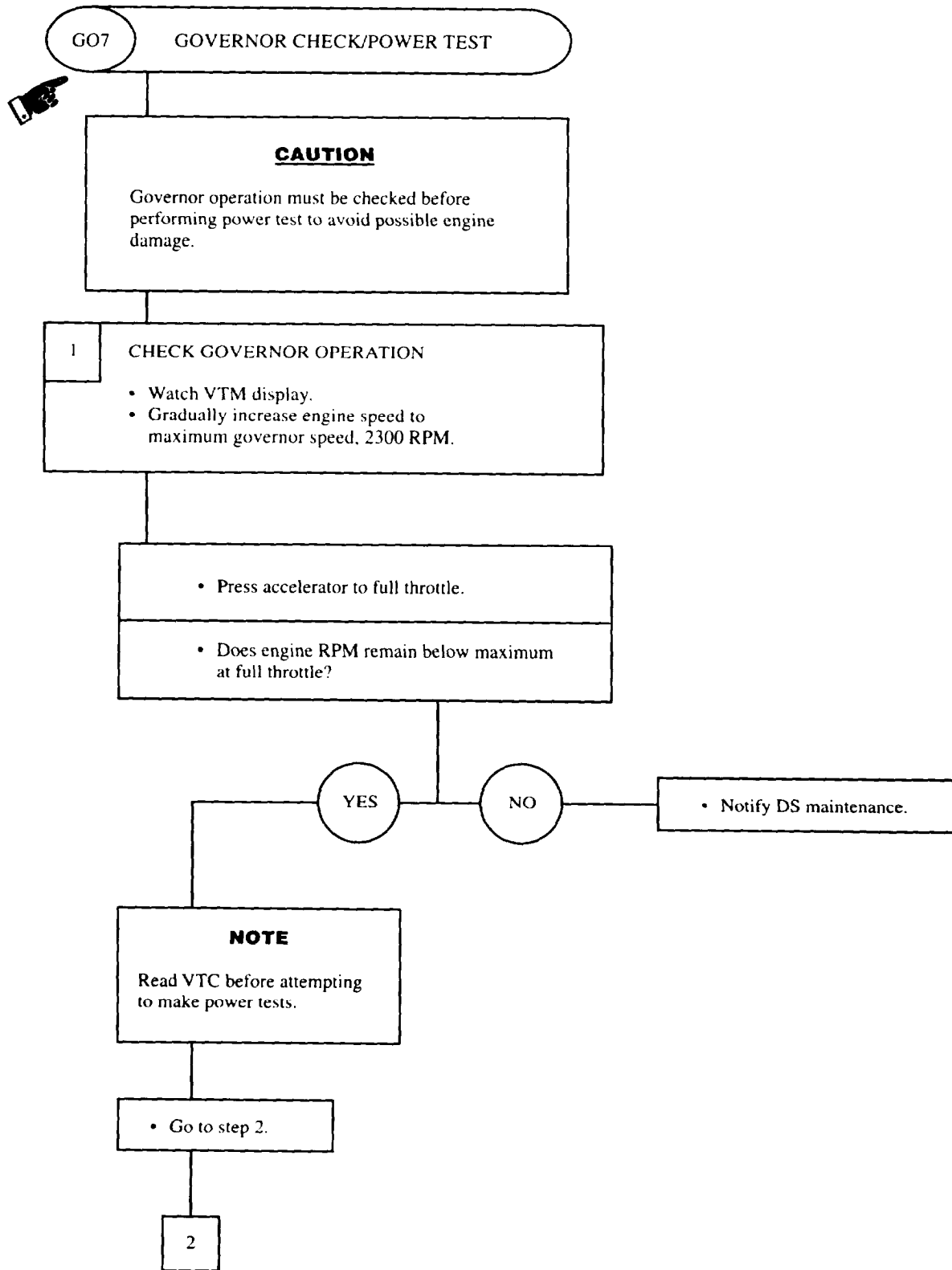
STE/ICE Go/No-Go Chain (Cont)



STE/ICE Go/No-Go Chain (Cont)



STE/ICE Go/No-Go Chain (Cont)



STE/ICE Go/No-Go Chain (Cont)

GO7 GOVERNOR CHECK/POWER TEST (Cont)

CAUTION

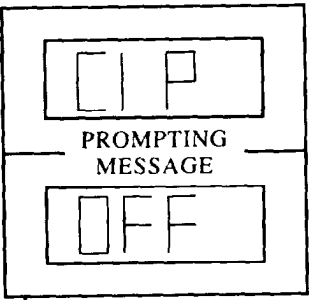
Do not perform power test if engine temperature is above normal operating temperature. Engine should be at operating temperature before performing power test.

NOTE

- Read VTC before attempting tests 12 or 13.
- If using test 12, the first number to appear on the VTM is signal to release accelerator.

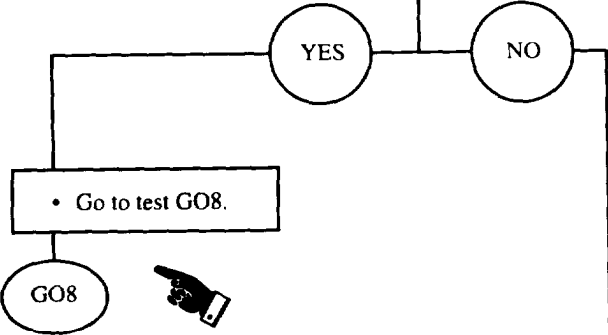
2 PERFORM POWER TEST

- Dial 12 or 13 into TEST SELECT and press and release TEST.
- Wait for prompting message CIP to appear.
- When CIP appears, press down on accelerator and hold to floor until VTM displays OFF.
- When OFF appears, release accelerator.
- Displayed number is power test result.



• Is power within limits?

| TEST NO. | POWER: RPM/SEC |
|----------|----------------|
| 12 | TBD |



| TEST NO. 13 | | |
|------------------------------|-----------------|---------------|
| % POWER: MINIMUM TEST LIMITS | | |
| ALTITUDE | | |
| 0 to 2000 ft | 2000 to 4000 ft | Above 4000 ft |
| 75% | 66% | 60% |

STE/ICE Go/No-Go Chain (Cont)

GO8 COMPRESSION UNBALANCE TEST

CAUTION
Be sure batteries are at full charge.
Do not perform more than two compression unbalance tests in a row or vehicle batteries may be discharged.

NOTE
Compression unbalance tests 14 and 15 differ only in the way they are connected to vehicle. Test 14 requires no connection other than VTM power from vehicle being tested. Test 15 is only used if VTM is independently powered from one battery source, and vehicle from a second. In this case, test probe leads have to be connected to battery which is used to crank engine.

1 WARM UP ENGINE

- Run engine until it reaches normal operating temperature.
- Run engine at fast idle for an additional two minutes.
- Stop engine.

2 SET UP ENGINE TO PREVENT STARTING

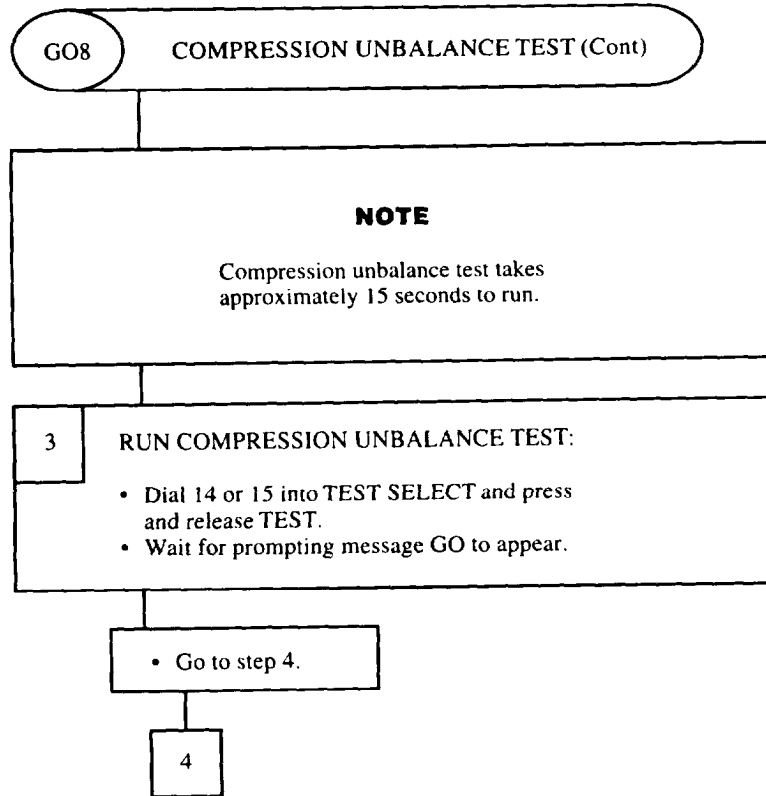
- Keep ENGINE STOP switch depressed during cranking.

• Go to step 3.

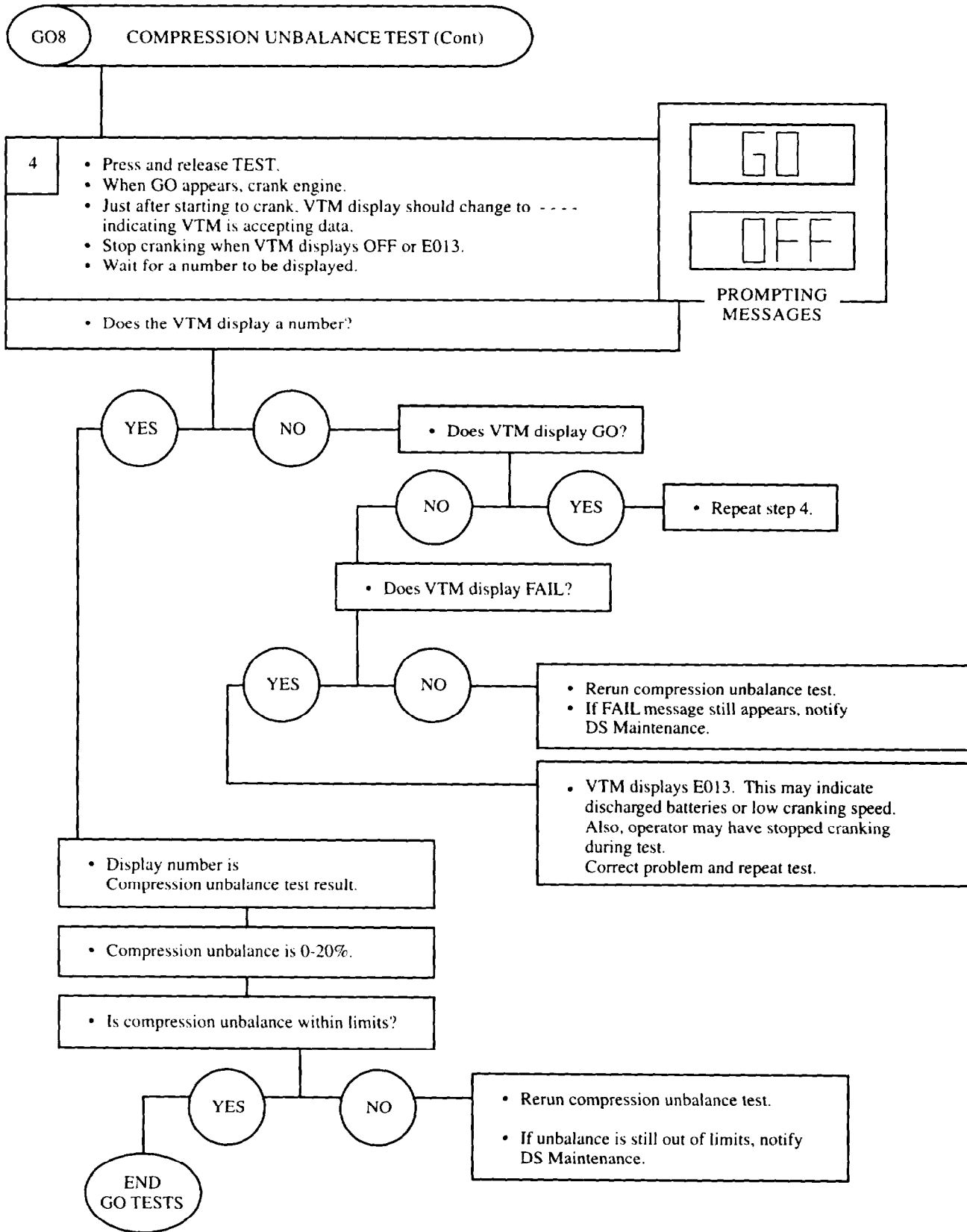
3



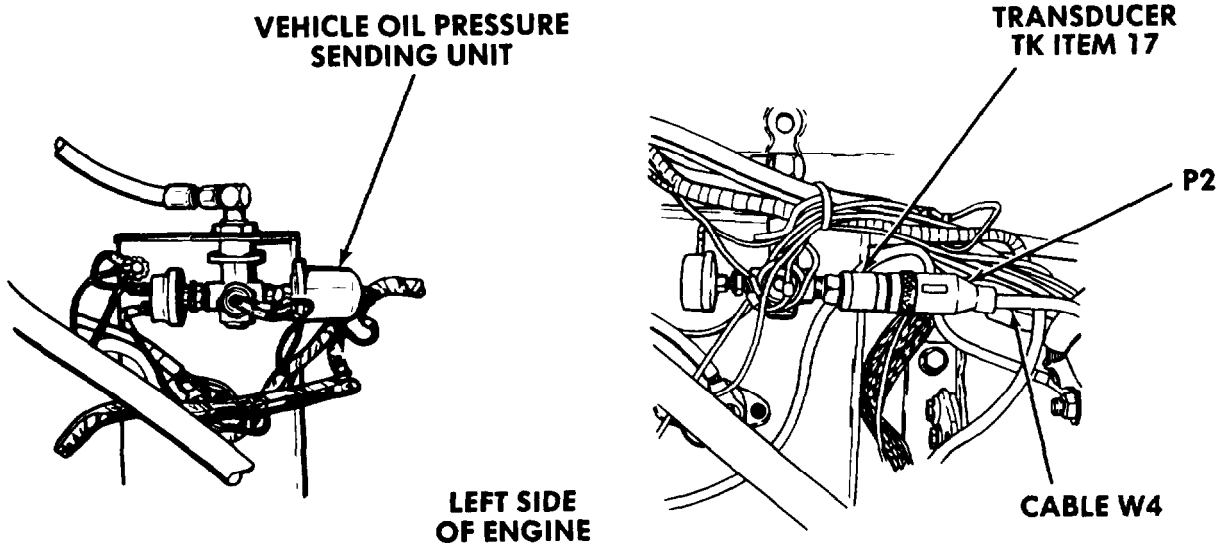
STE/ICE Go/No-Go Chain (COW)



STE/ICE Go/No-Go Chain (Cont)



STE/ICE Go/No-Go Chain (Cont)



NG05 LOW OIL PRESSURE CHECK

1 INSTALL TRANSDUCER - DO OFFSET TEST:

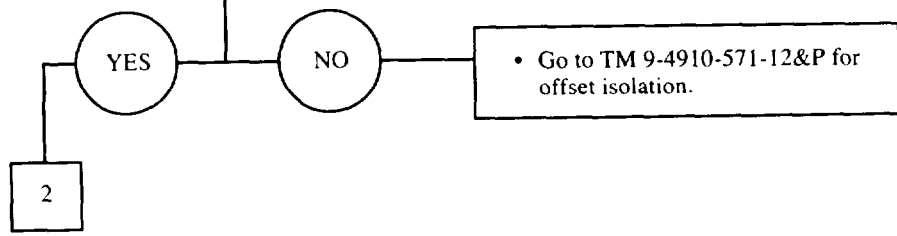
- Stop engine.
- Remove oil pressure sending unit.
- Install pressure transducer TK item 17 (blue stripe) in place of sending unit on engine.
- Connect P1 of transducer cable W4 to J2 or J3 on VTM.
- Connect P2 of transducer cable to the connector on the pressure transducer.

- Dial 50 into TEST SELECT.
- Press and hold TEST until CAL message appears on display.
- Release TEST.
- Wait for offset value to appear on display.

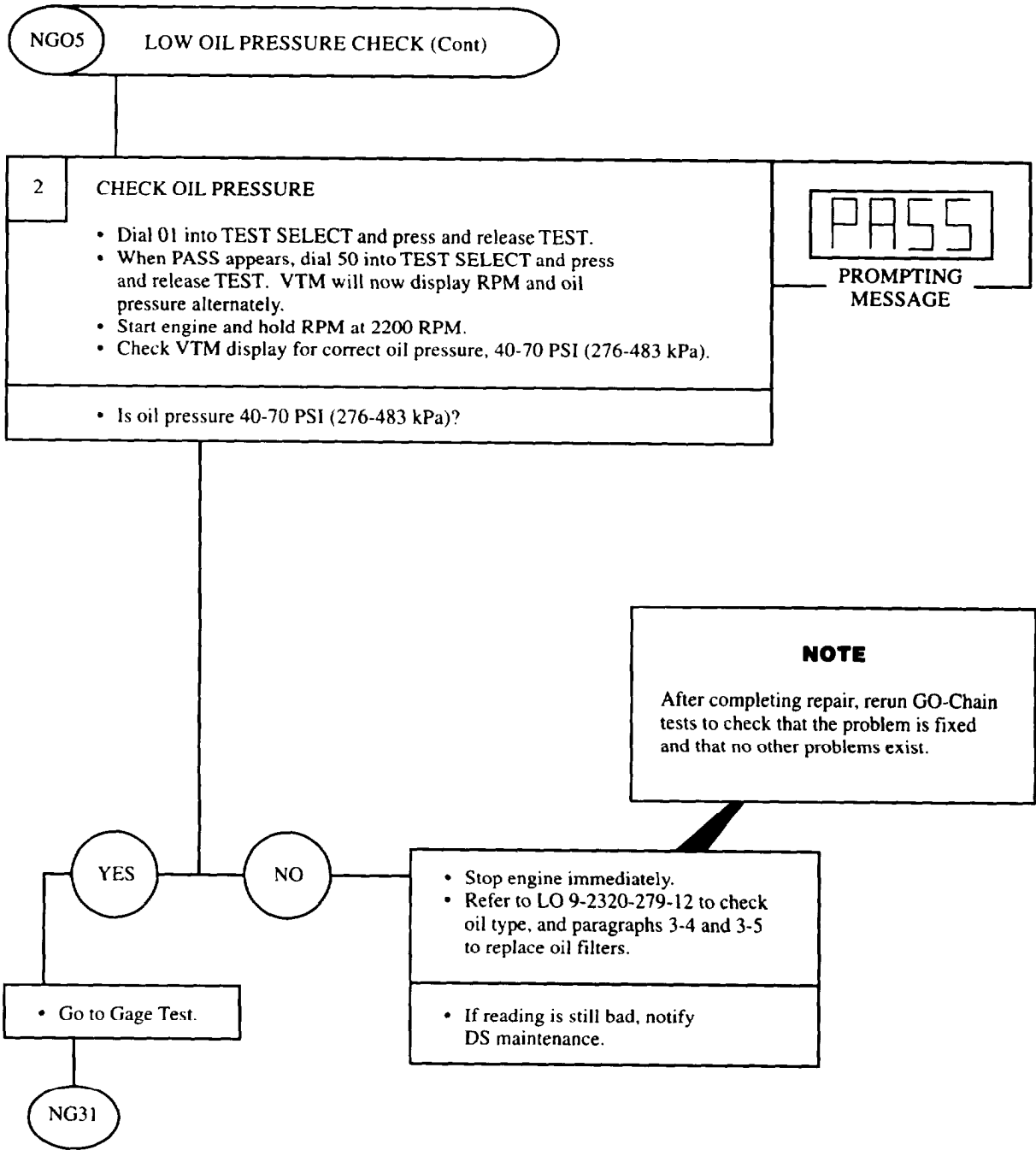
• Is the offset value within limits -150 to +150?



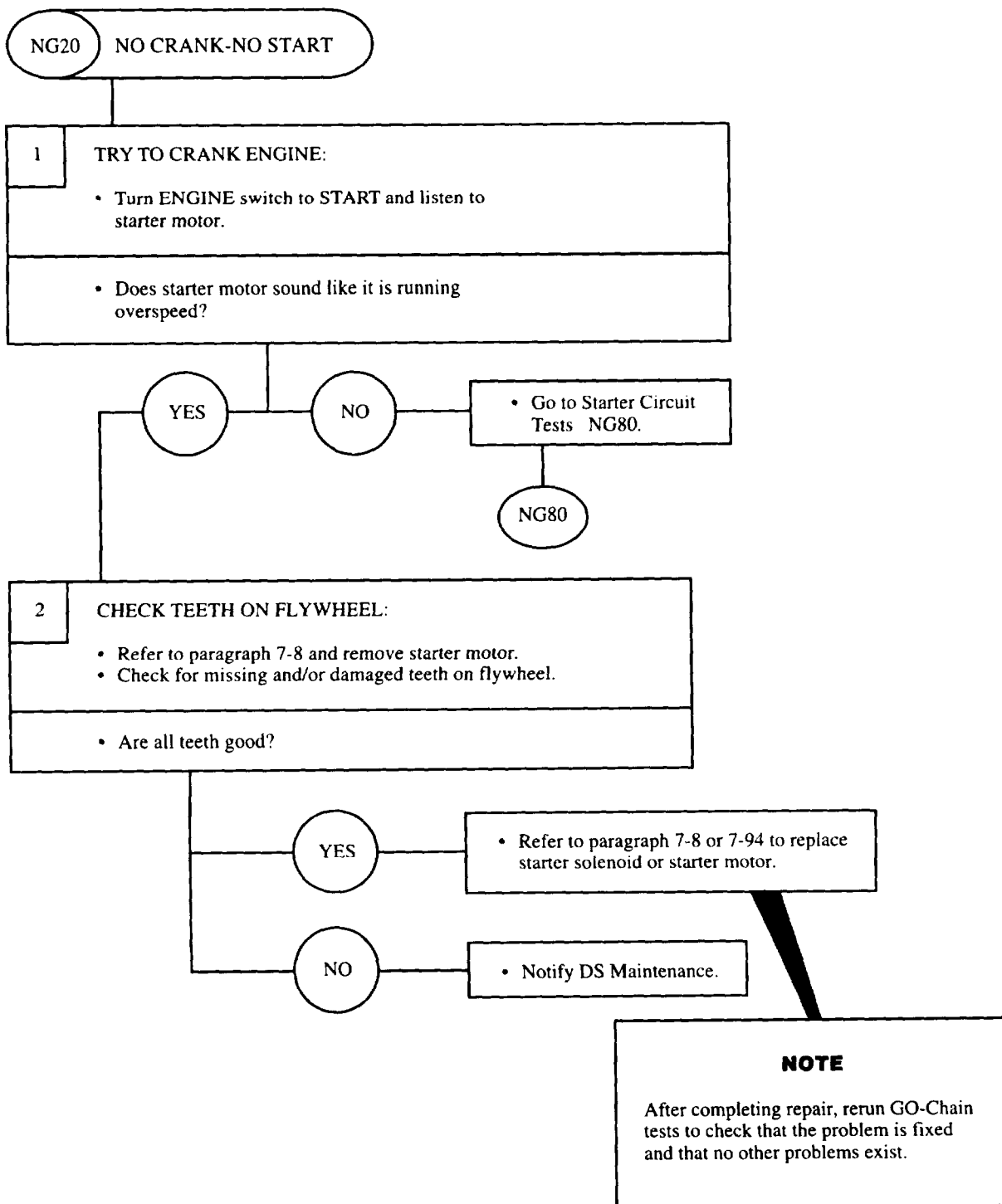
PROMPTING MESSAGE



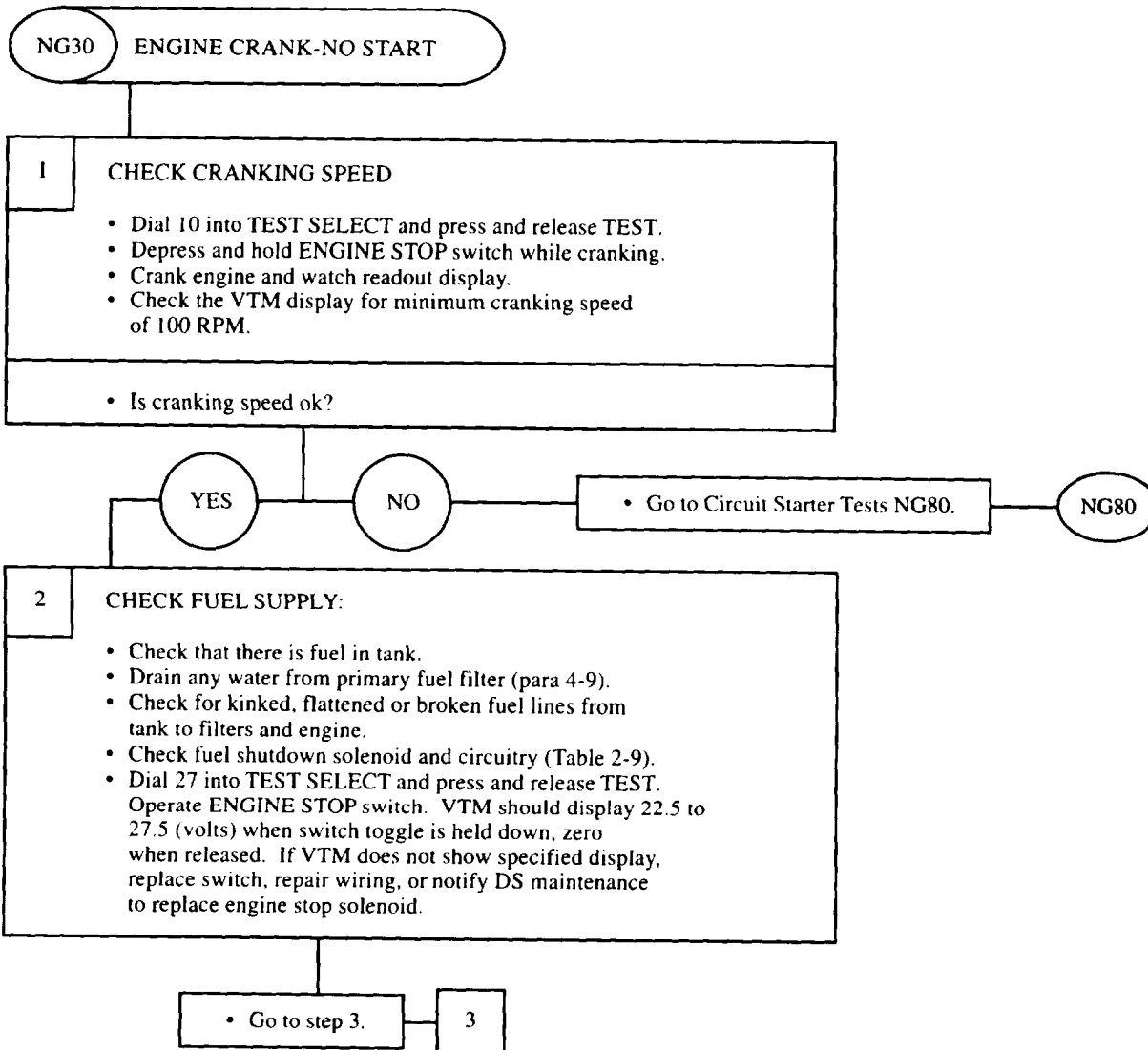
STE/ICE Go/No-Go Chain (Cont)



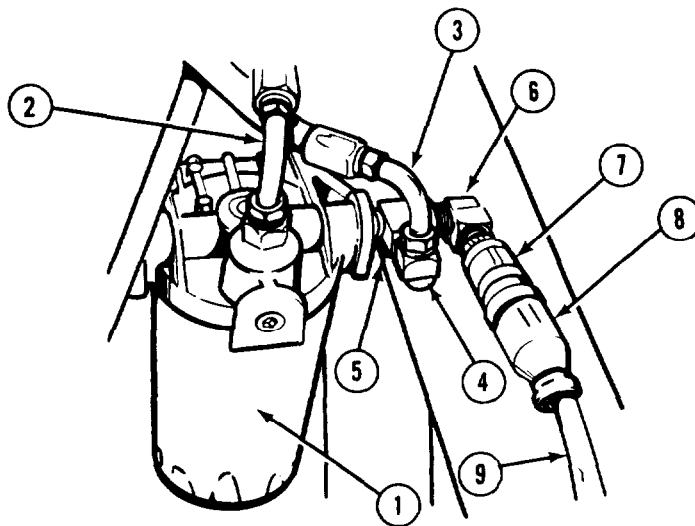
STE/ICE Go/No-Go Chain (Cont)



STE/ICE Go/No-Go Chain (Cont)



STE/ICE Go/No-Go Chain (Cont)



SECONDARY FUEL FILTER

(RIGHT SIDE OF ENGINE)

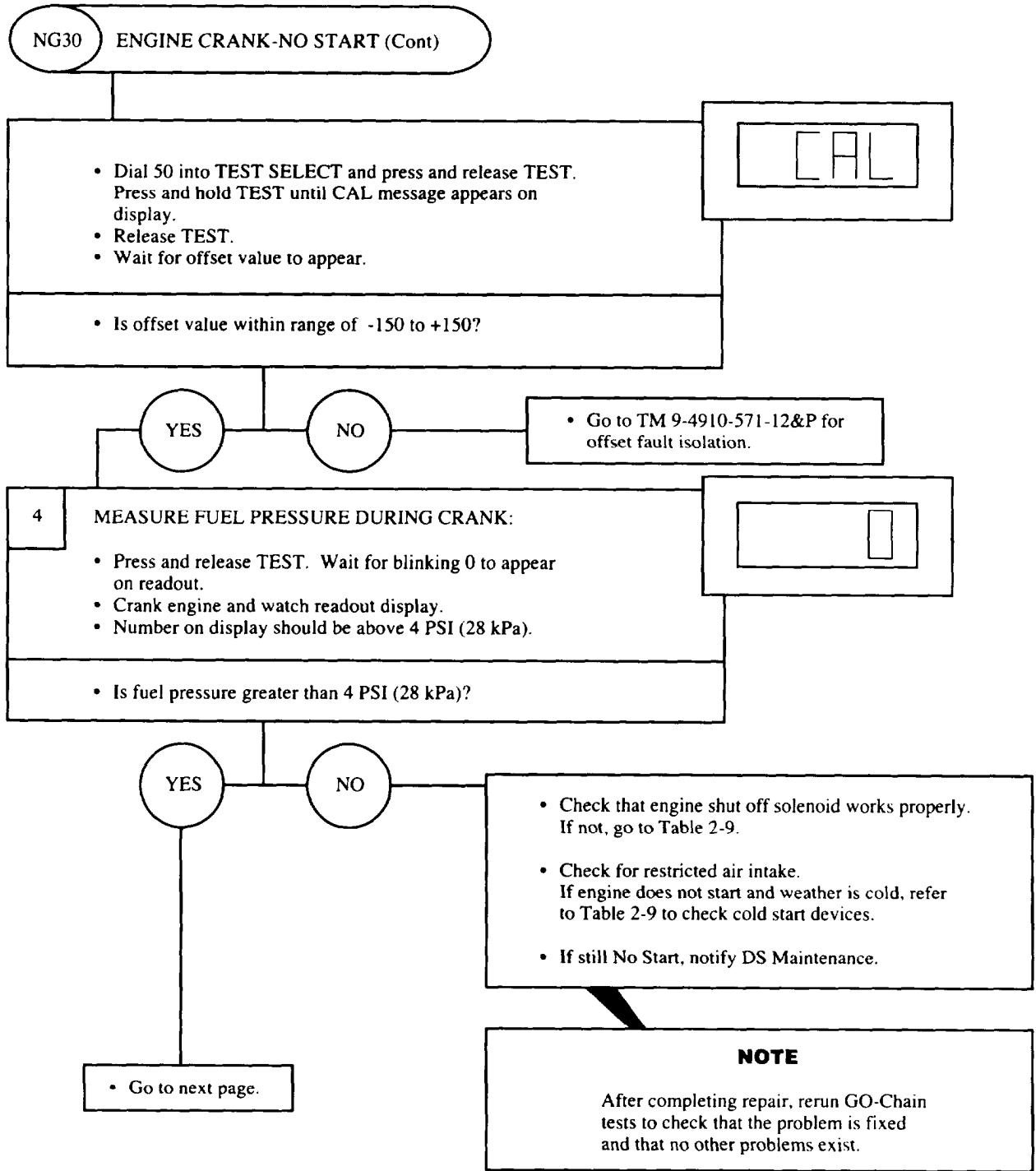
- (1) Secondary fuel filter
- (2) Inlet fuel lines
- (3) Outlet fuel line (to cylinder bank)
- (4) Fuel line adapter fitting
- (5) 1/4 street tee (TK item 24)
- (6) 1/4 street elbow (TK item 26)
- (7) Pressure transducer, blue line (TK item 17)
- (8) Connector P2
- (9) Transducer cable W4

NG30 ENGINE CRANK - NO START (Cont)

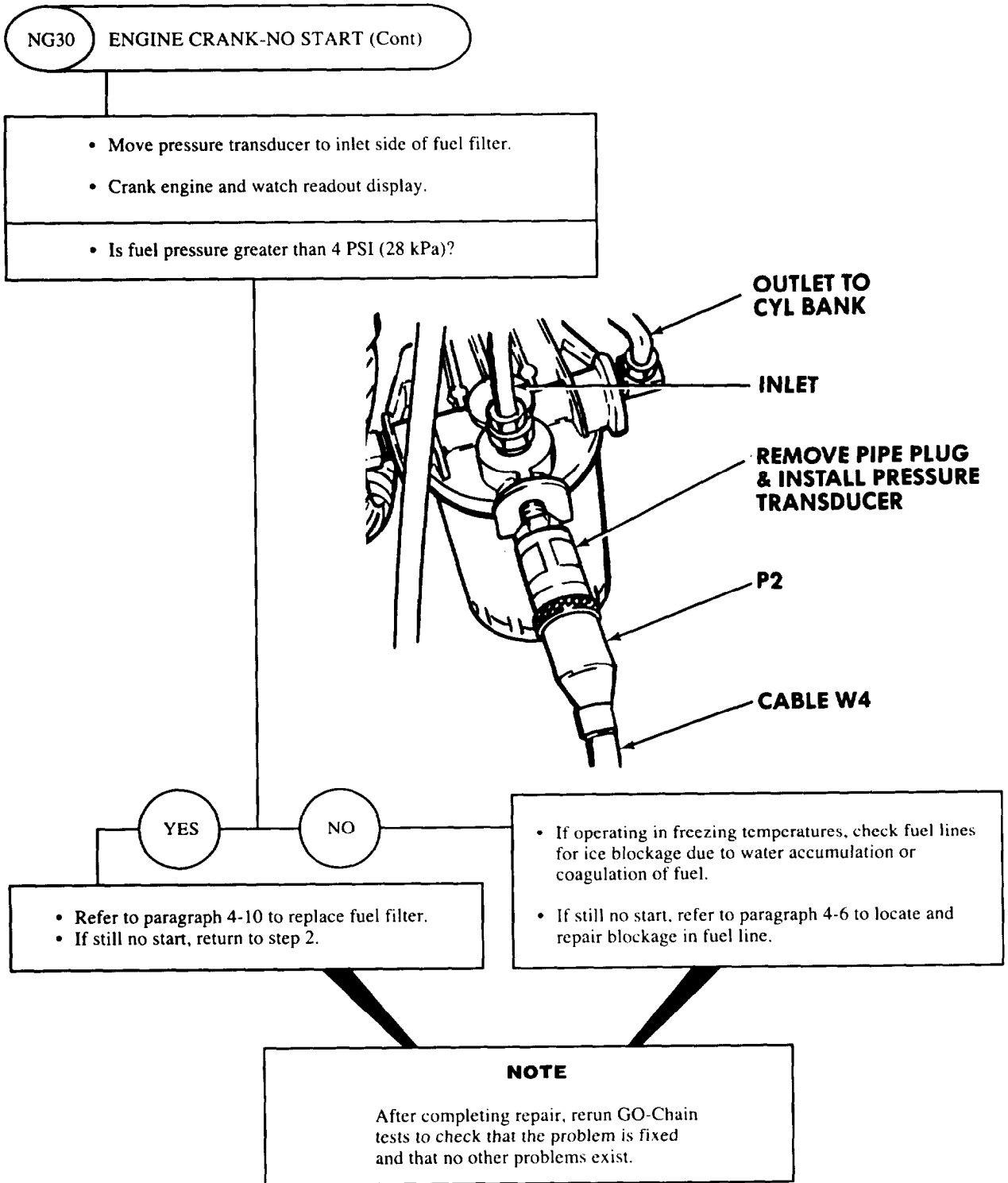
| | |
|----------|--|
| 3 | <p>INSTALL TRANSDUCER:</p> <ul style="list-style-type: none"> • Disconnect fuel line at secondary fuel filter outlet. • Remove fuel line adapter fitting from fuel filter. • Install 1/4 street tee (TK item 24) in fuel filter. • Install fuel line adapter fitting in side outlet of street tee. • Install 1/4 street elbow (TK item 26) in female end outlet of street tee. • Connect fuel line to adapter fitting. • Install blue line pressure transducer (TK item 17) in female outlet of street elbow. • Connect P1 of transducer cable W4 to J2 on VTM. • Connect P2 of transducer cable to connector on transducer. |
|----------|--|

• Go to next page.

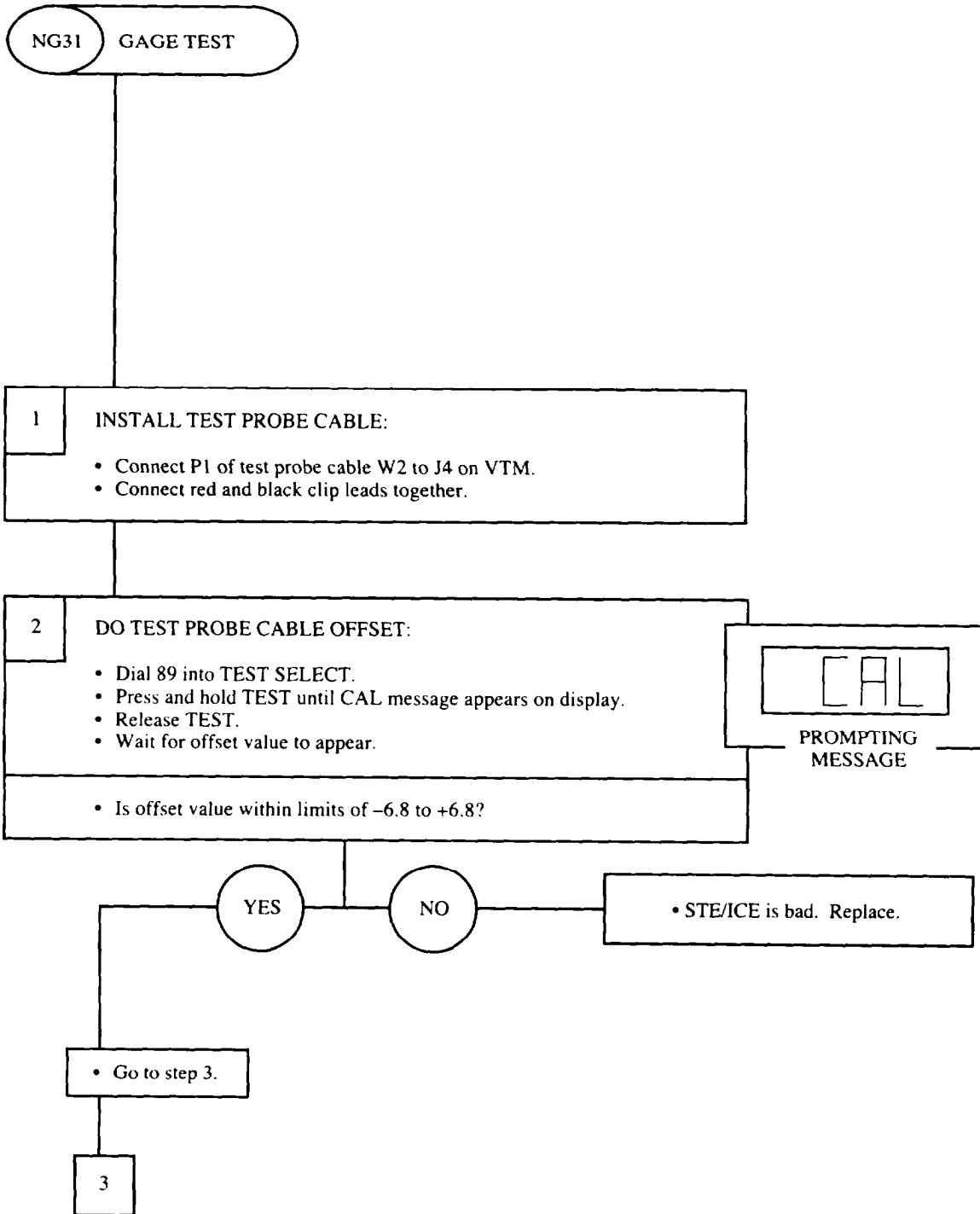
STE/ICE Go/No-Go Chain (Cont)



STE/ICE Go/No-Go Chain (Cont)



STE/ICE Go/No-Go Chain (Cont)



STE/ICE Go/No-Go Chain (Cont)

NG31 GAGE TEST (Cont)

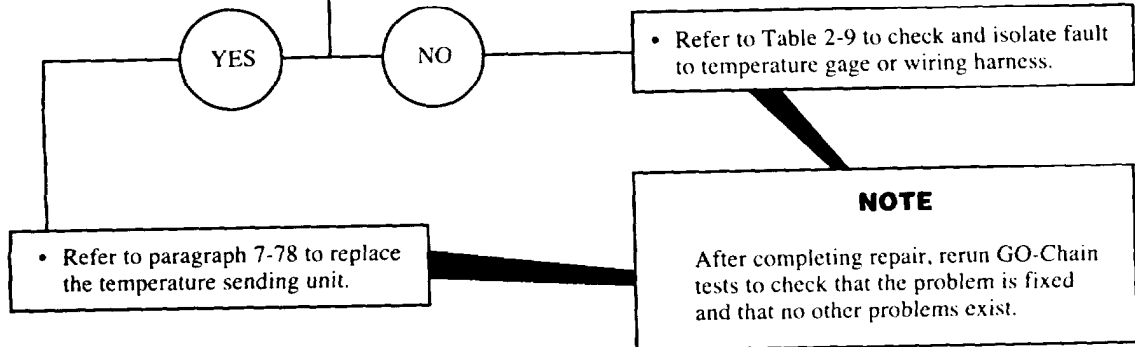
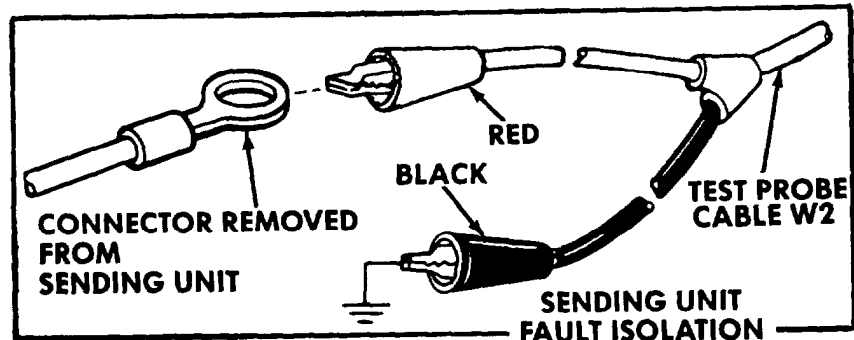
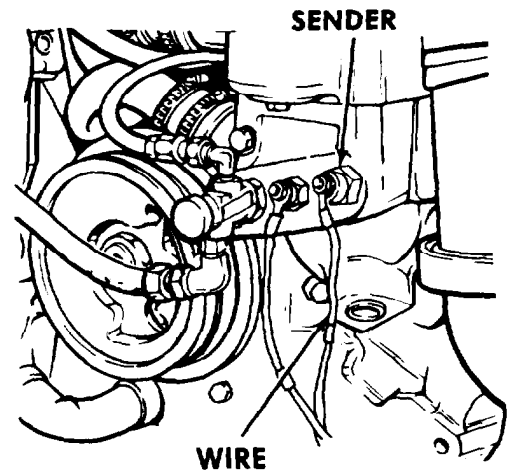
3 ISOLATE FAULT TO SENDING UNIT OR GAGE.

- Remove wire from temperature sending unit on vehicle.
- Connect red clip lead of W2 to wire removed from sending unit.
- Connect black clip lead to chassis ground.
- Turn ENGINE switch ON.

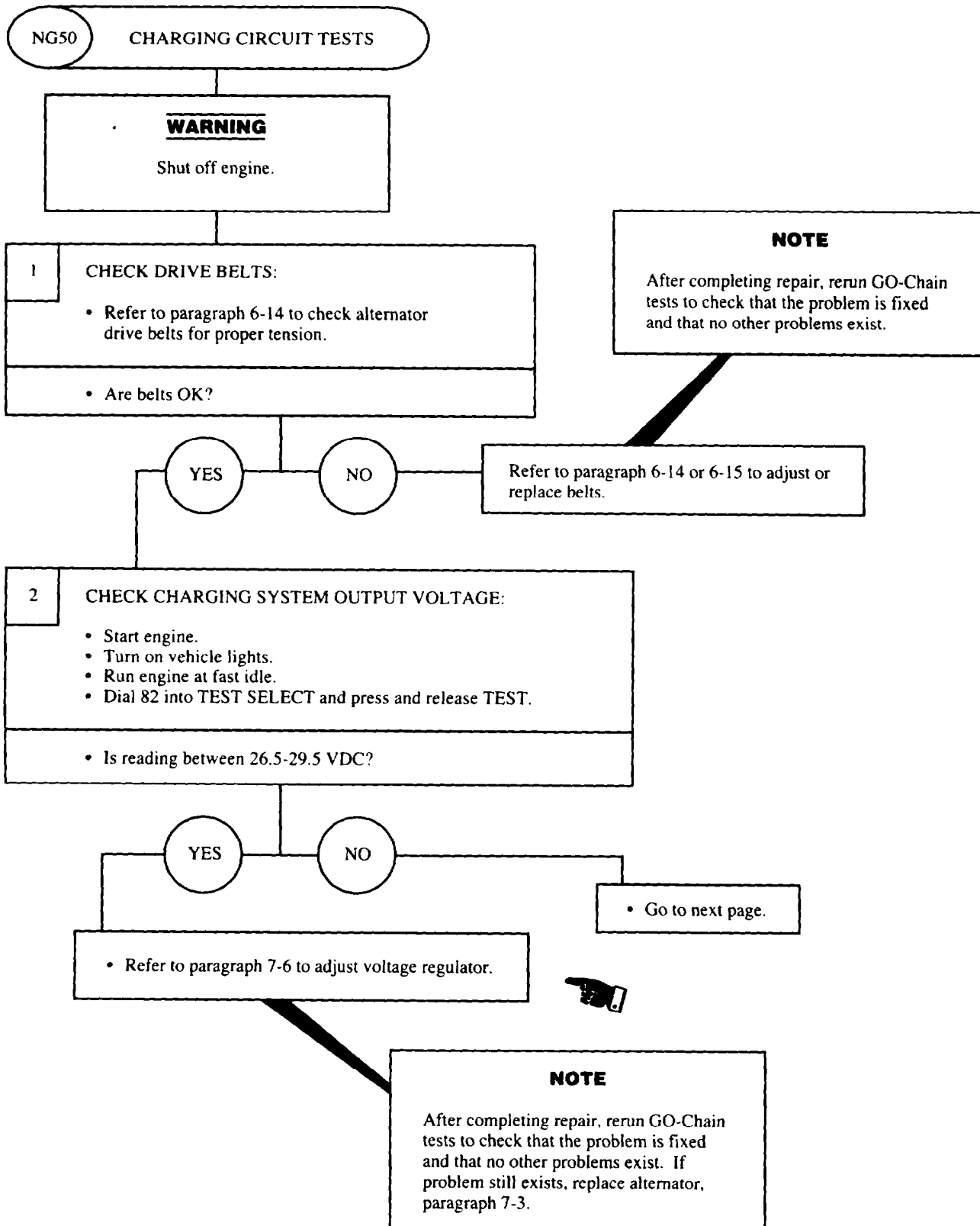
• Does VTM indicate 6-9 volts?

NOTE

Temperature gage test is typical for any gage. Refer to Chapter 7, Table of Contents, for list of gage and sending unit maintenance procedures.



STE/ICE Go/No-Go Chain (Cont)



STE/ICE Go/No-Go Chain (Cont)

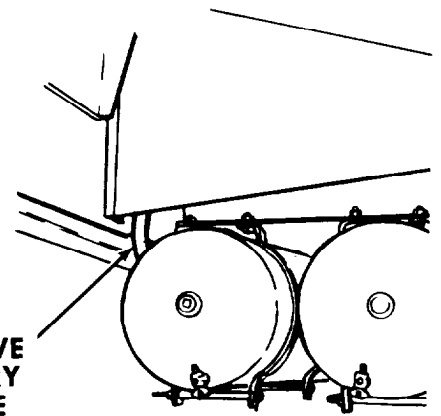
NG80 STARTER CIRCUIT TESTS

NOTE

While cranking engine with bad or discharged batteries, VTM can lose power and come on again after cranking has stopped, displaying - - -. If this occurs, clean battery posts and clamps and try again. If VTM still loses power, connect VTM power cable to good batteries in another vehicle and perform the following tests using test probe cable W2.

1 INSTALL CURRENT PROBE:

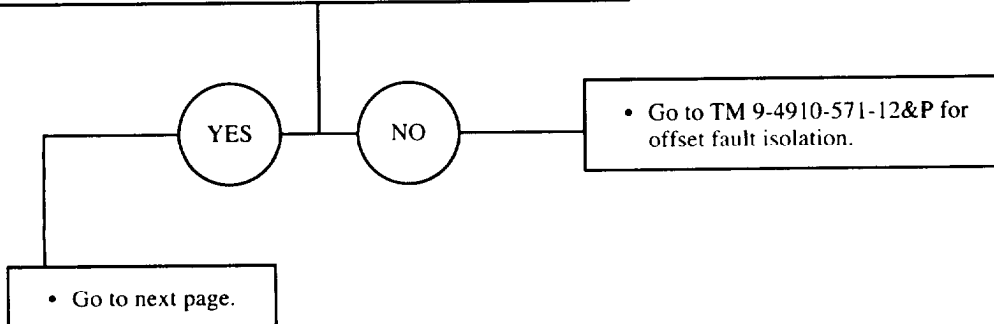
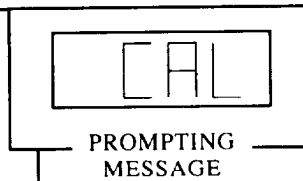
- Install current probe around positive battery cable to starter motor.
- Point arrow on probe away from starter motor.



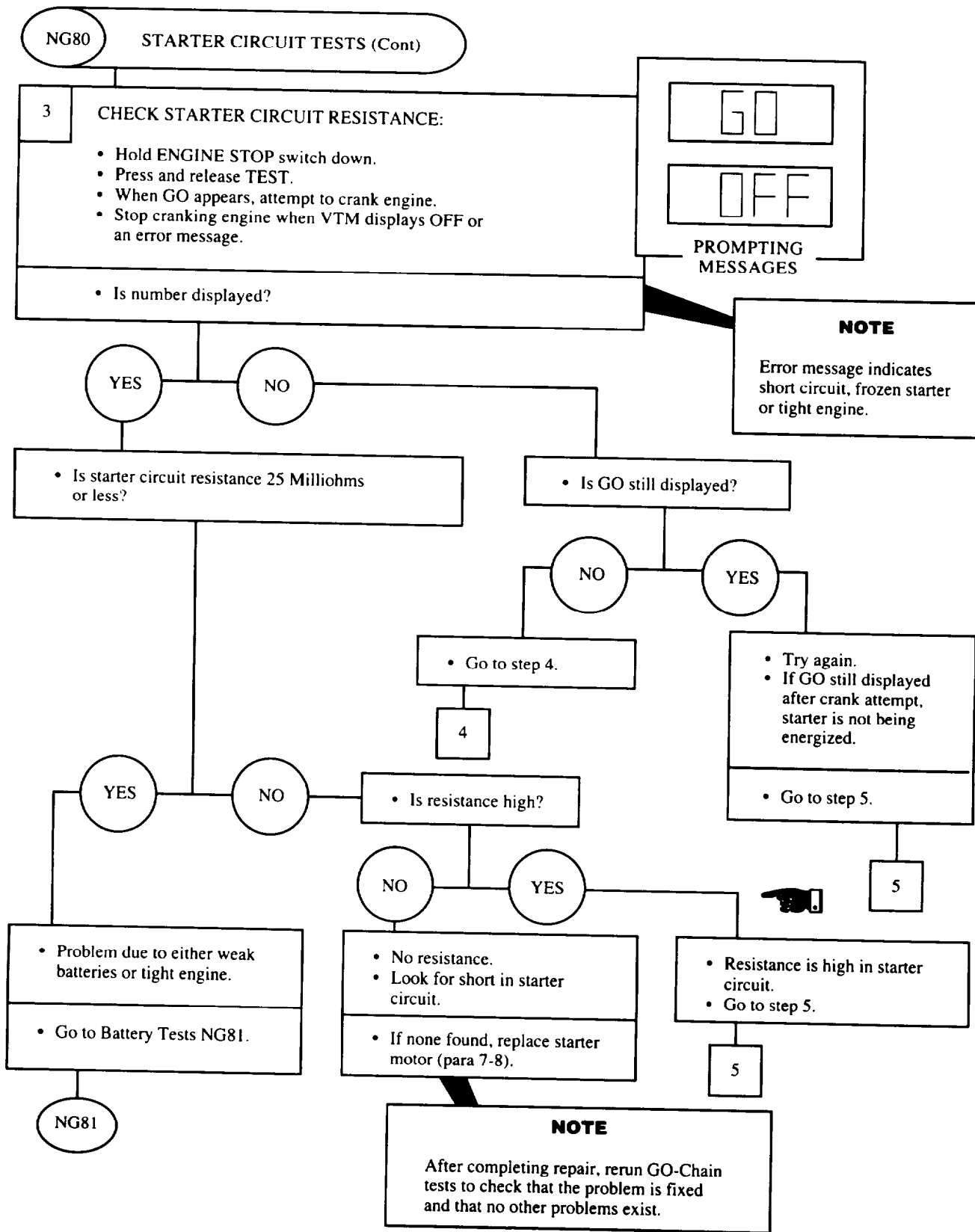
2 DC CURRENT PROBE OFFSET:

- Turn off all vehicle electrical power.
- Dial 74 into TEST SELECT.
- Press and hold TEST until CAL message appears.
- Release TEST.
- Wait for offset value to appear.

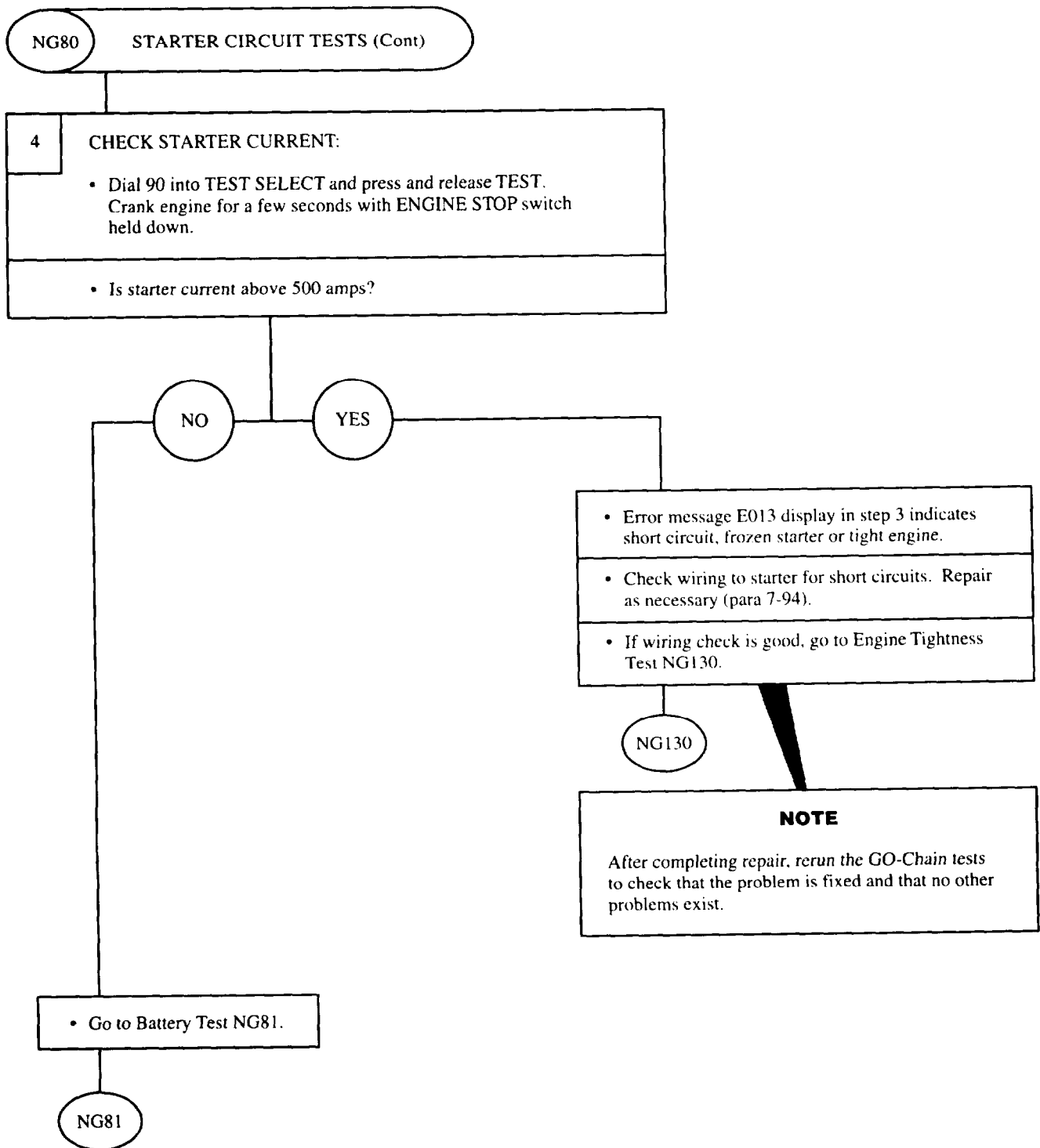
• Is offset value within limits of -225 to +225.



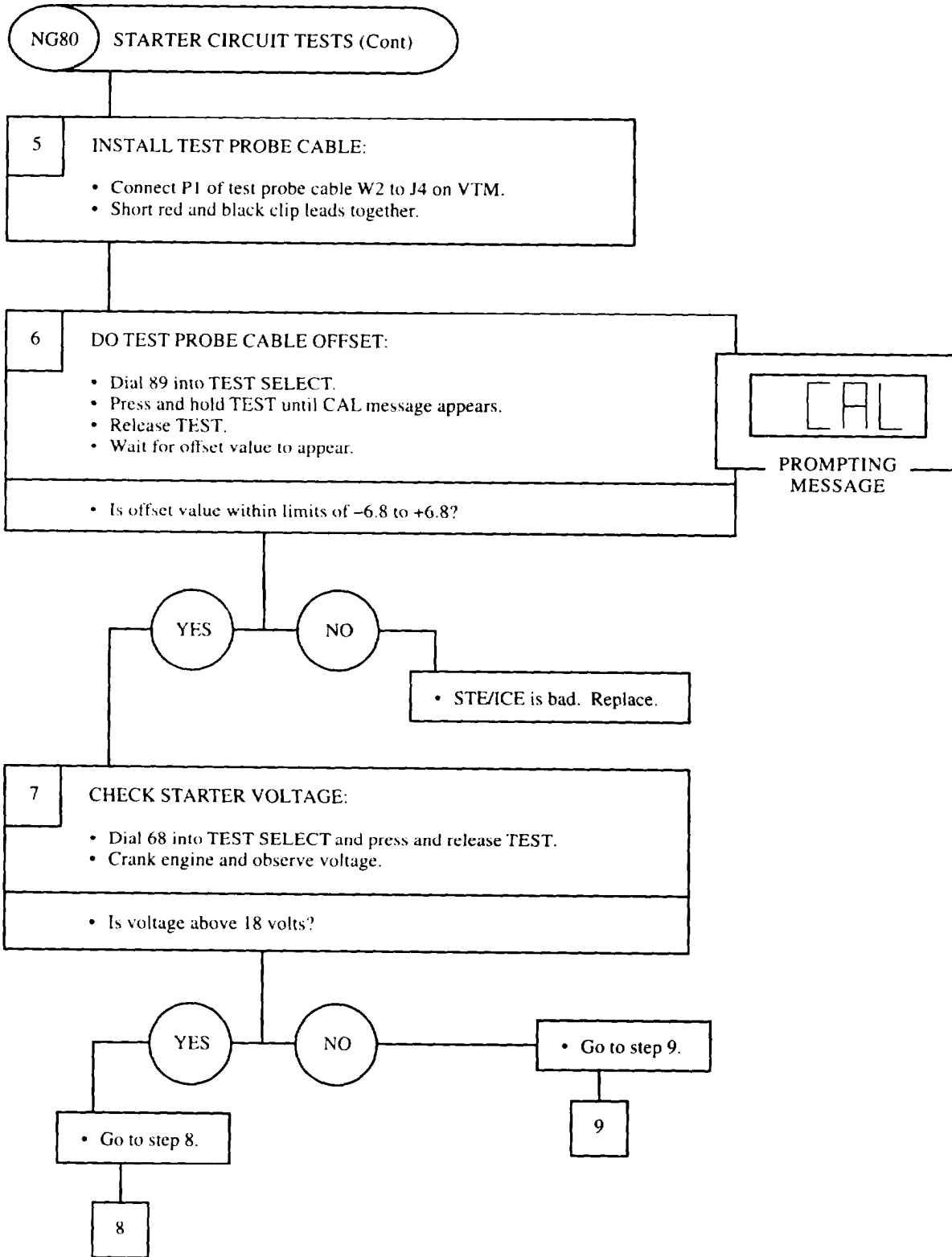
STE/ICE Go/No-Go Chain (Cont)



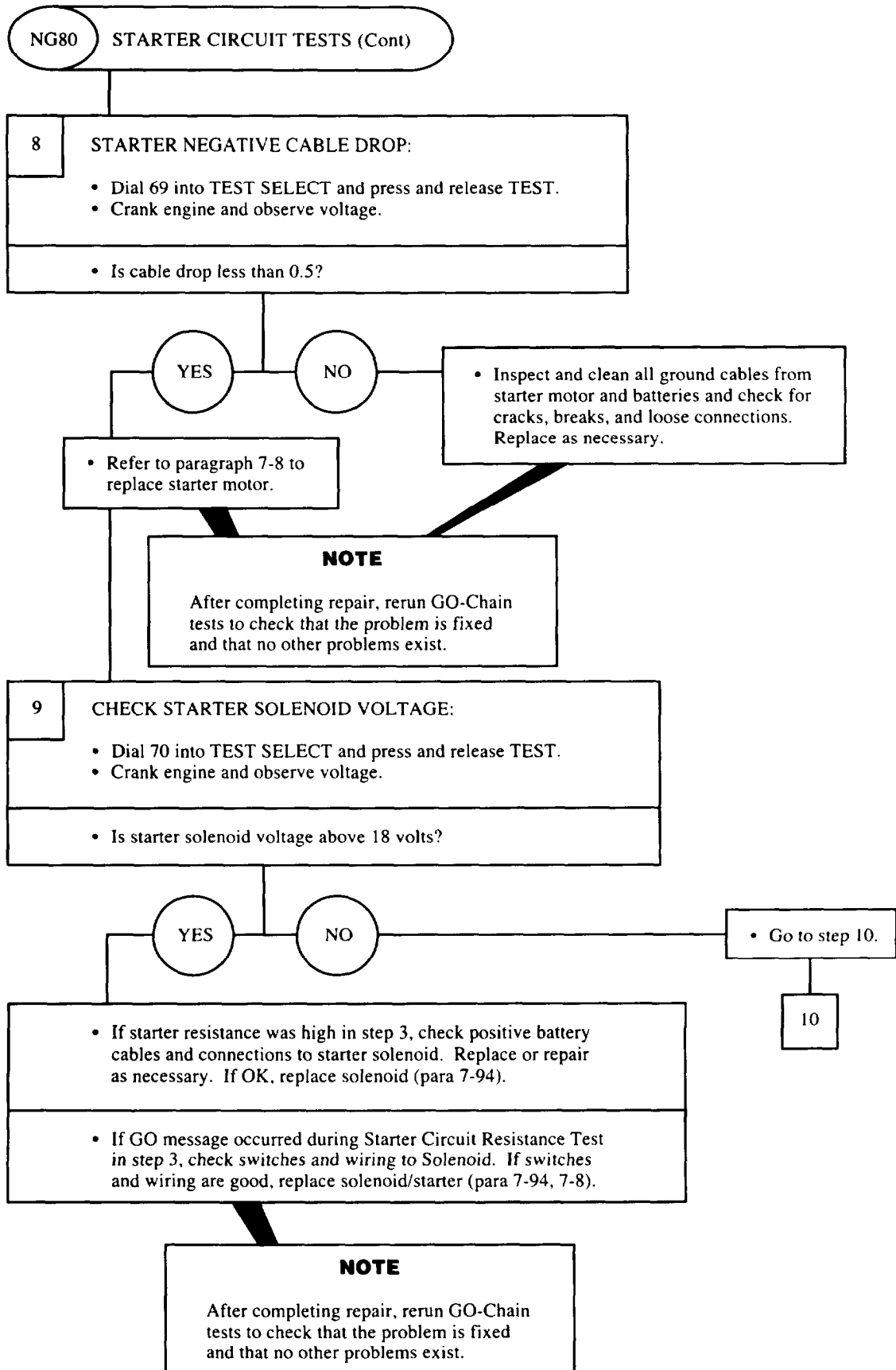
STE/ICE Go/No-Go Chain (Cont)



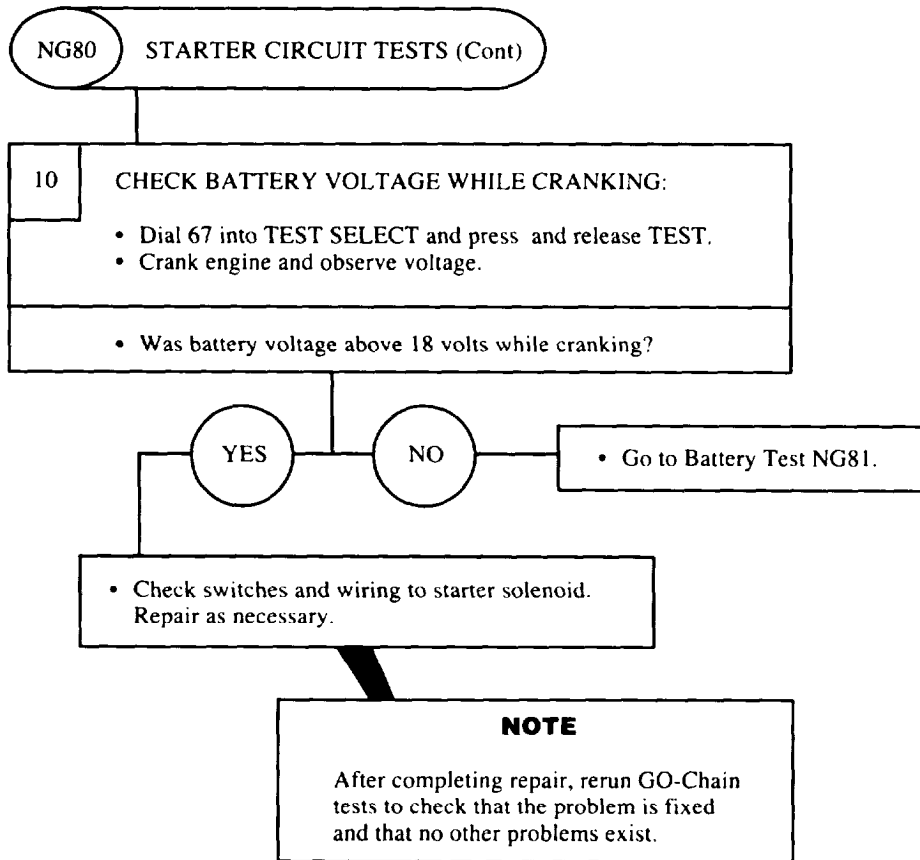
STE/ICE Go/No-Go Chain (Cont)



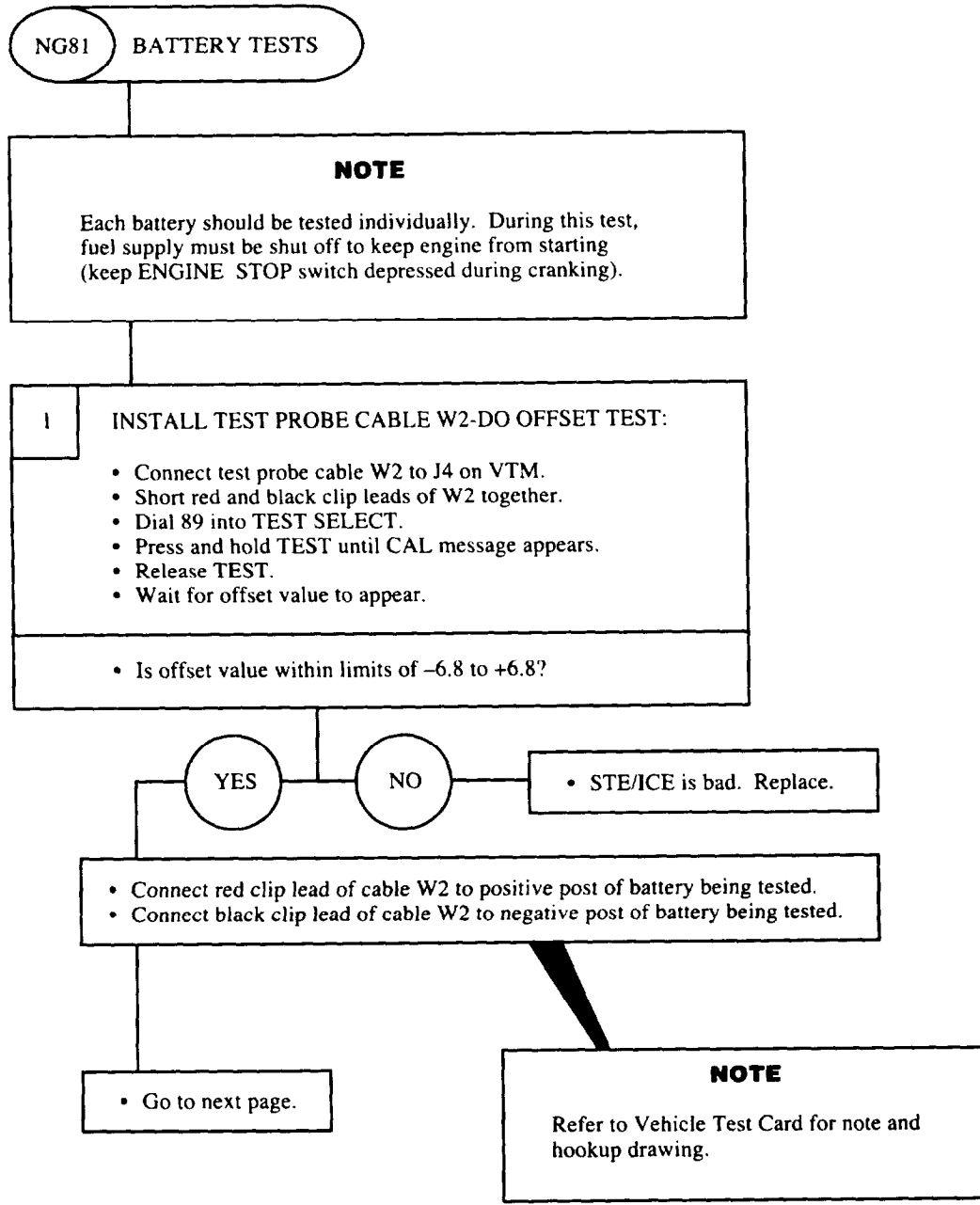
STE/ICE Go/No-Go Chain (Cont)



STE/ICE Go/No-Go Chain (Cont)



STE/ICE Go/No-Go Chain (Cont)



STE/ICE Go/No-Go Chain (Cont)

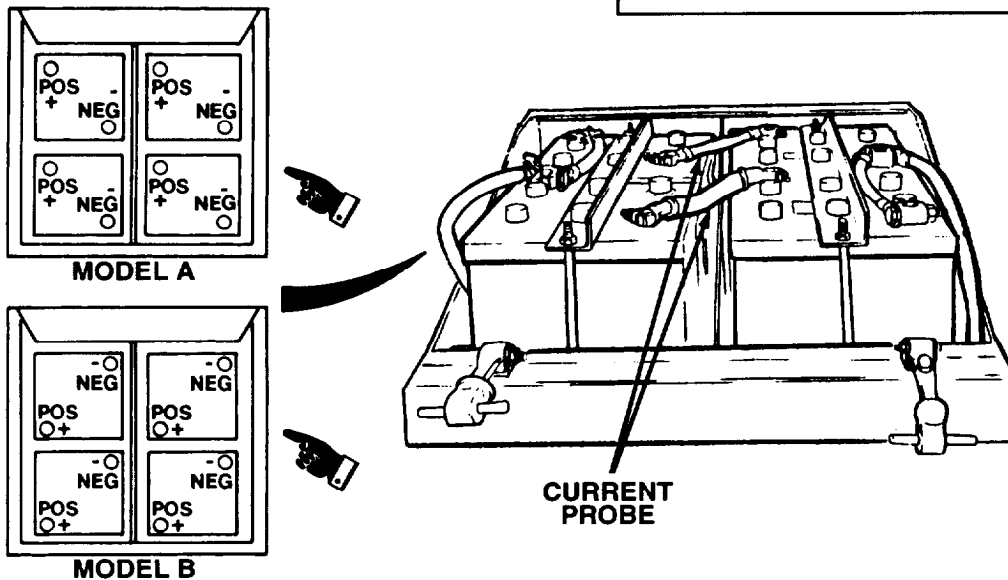
NG81 BATTERY TESTS (Cont)

2 CONDITION CURRENT PROBE – DO OFFSET:

- Connect P1 of transducer cable W4 to J3 of VTM.
- Connect P2 of transducer cable W4 to current probe.
- Clamp current probe around battery cable which connects the series pair of batteries containing battery to be tested. Point arrow on current probe toward negative post connected to battery cable as shown.
- Attempt to crank engine for several cycles.

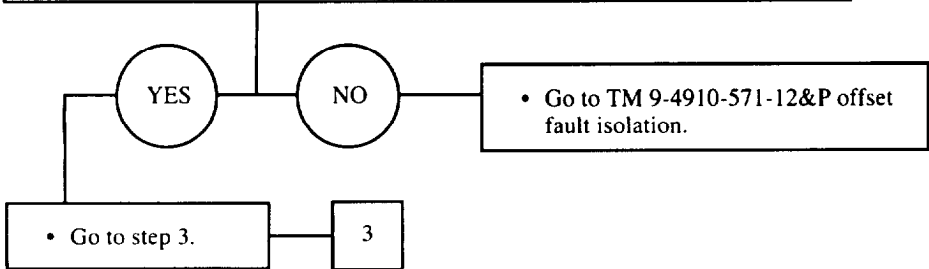
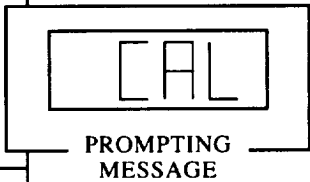
NOTE

- Refer to Vehicle Test Card for note and hookup drawing.
- There are two types of batteries. Model A is identified by a 6TN printed on the side of the battery, while Model B has a 6TL printed on the side of the battery.
- If Model A and B are combined on the same vehicle, all batteries will be positioned as shown for Model B.

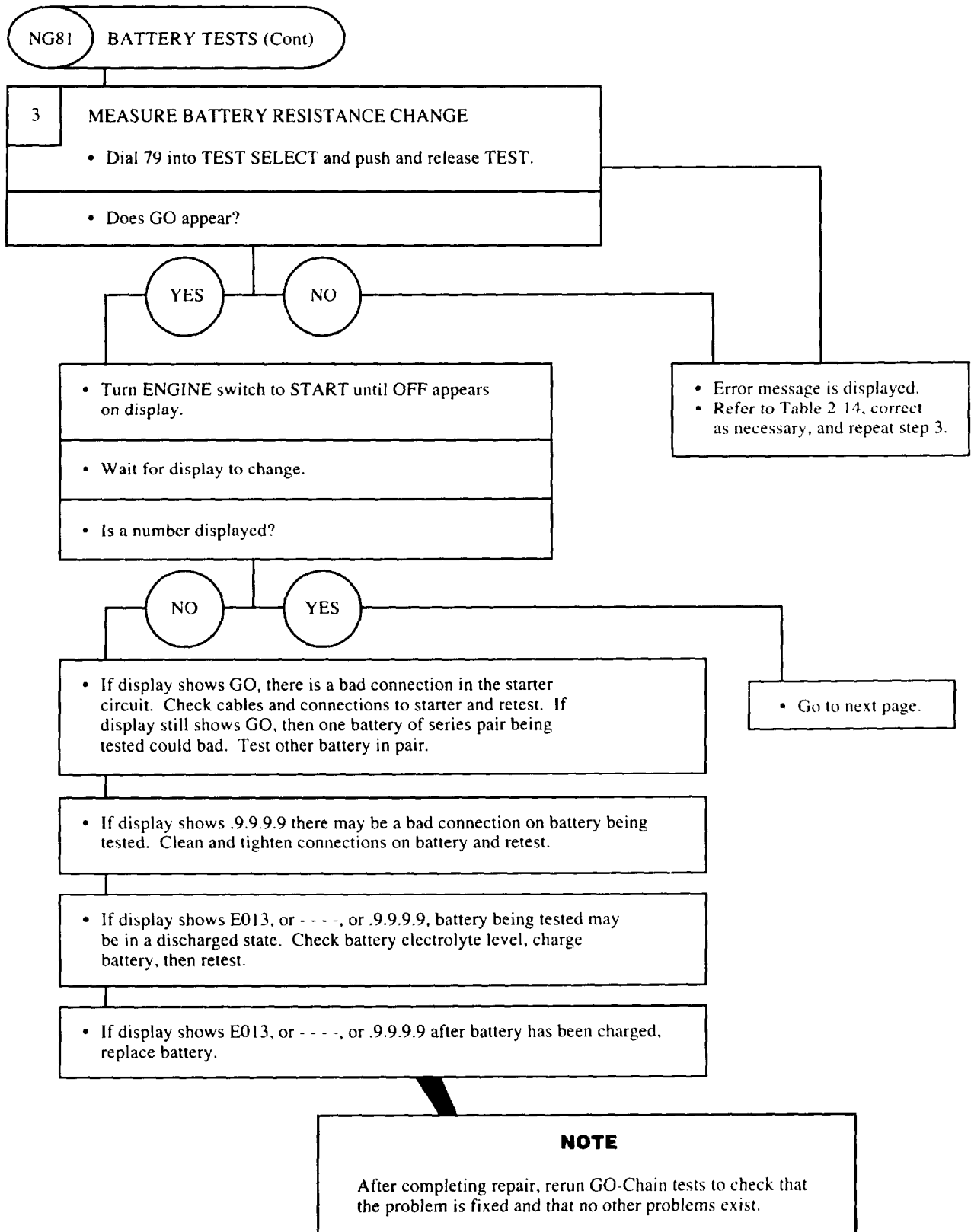


- Turn off all vehicle electrical power.
- Dial 90 into TEST SELECT.
- Press and hold TEST until CAL message appears.
- Release TEST.
- Wait for offset value to appear.

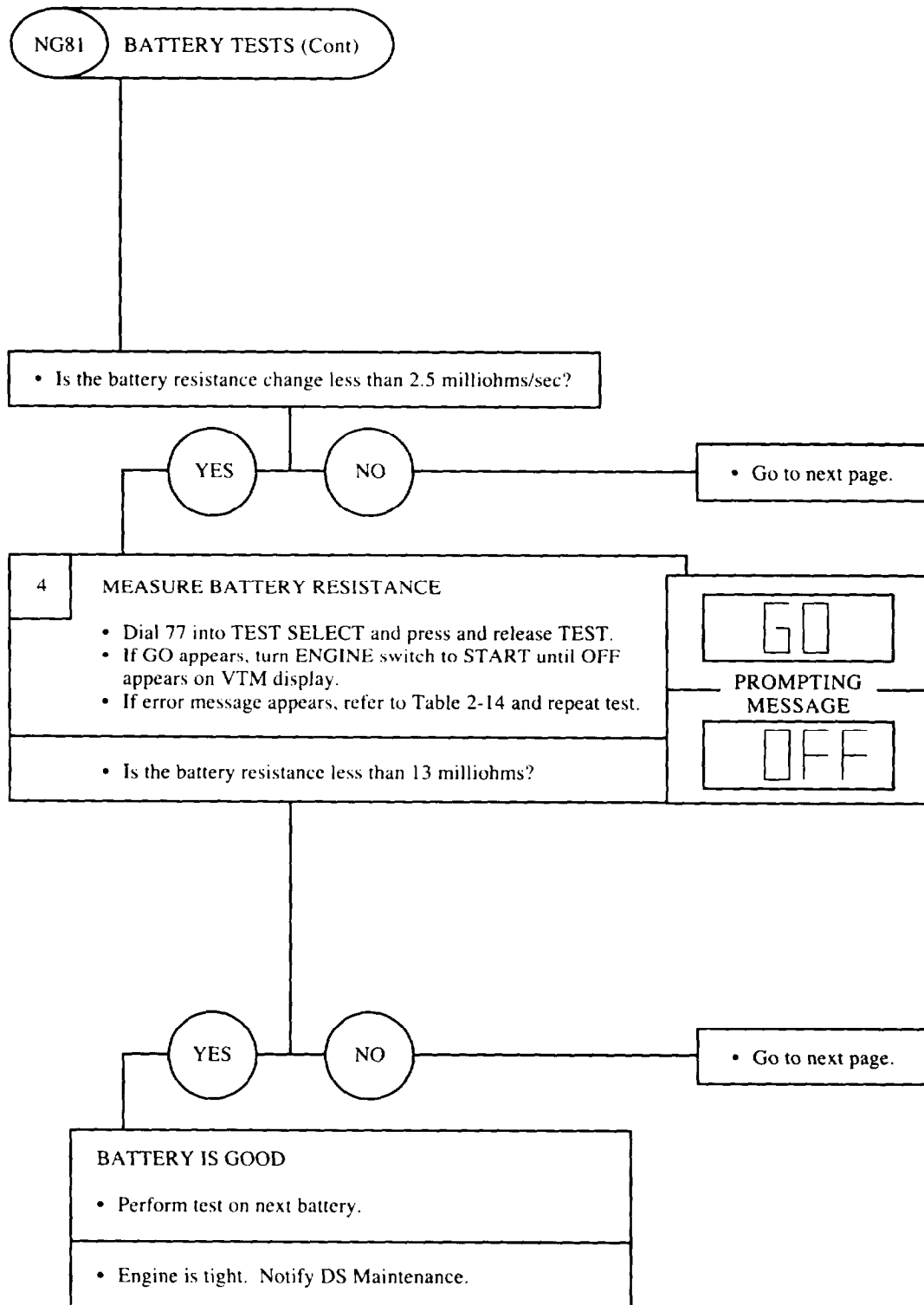
Is offset value within limits of -225 to +225?



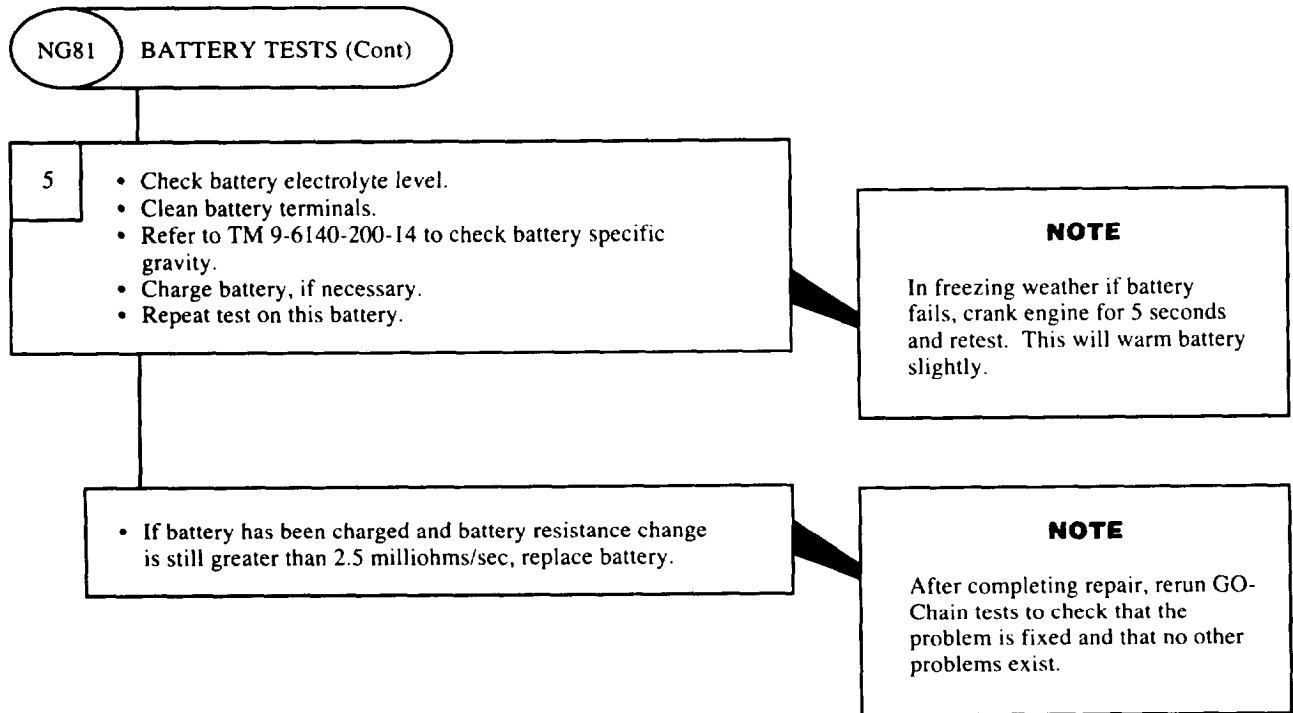
STE/ICE Go/No-Go Chain (Cont)



STE/ICE Go/No-Go Chain (Cont)



STE/ICE Go/No-Go Chain (Cont)



NG81 BATTERY TESTS (Cont)

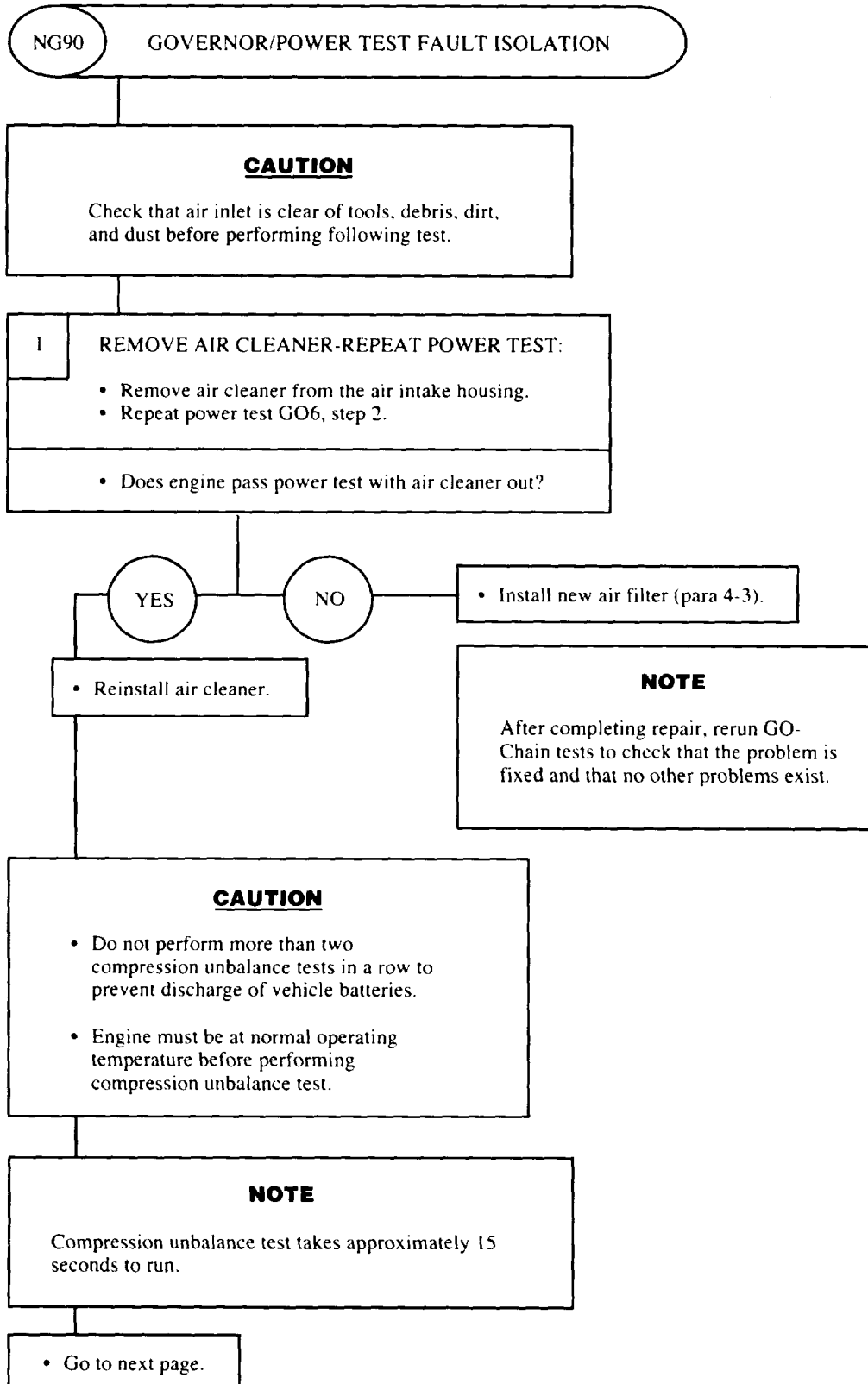
- 5
- Check battery electrolyte level.
 - Clean battery terminals.
 - Refer to TM 9-6140-200-14 to check battery specific gravity.
 - Charge battery, if necessary.
 - Repeat test on this battery.

NOTE
 In freezing weather if battery fails, crank engine for 5 seconds and retest. This will warm battery slightly.

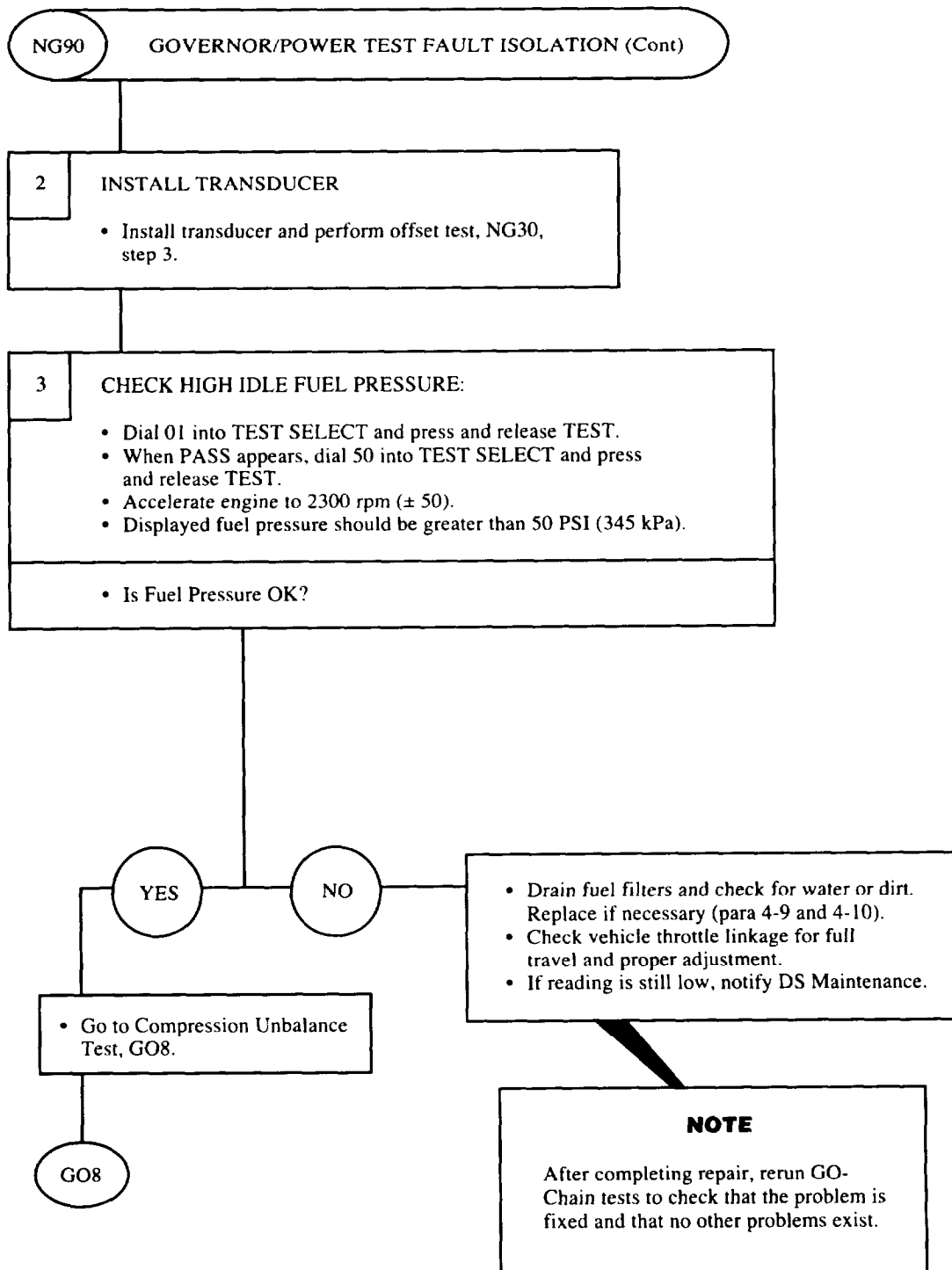
- If battery has been charged and battery resistance change is still greater than 2.5 milliohms/sec, replace battery.

NOTE
 After completing repair, rerun GO-Chain tests to check that the problem is fixed and that no other problems exist.

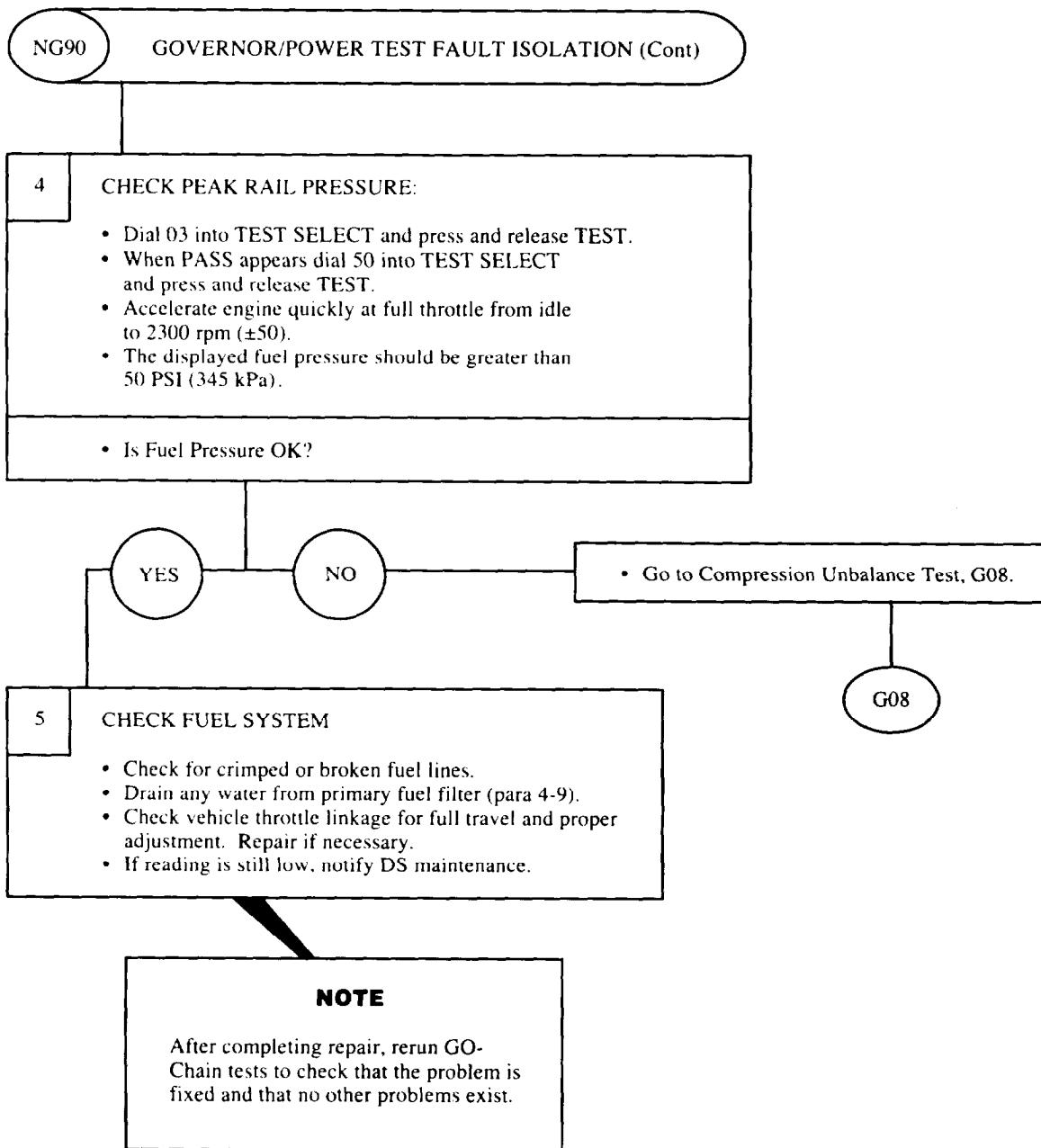
STE/ICE Go/No-Go Chain (Cont)



STE/ICE Go/No-Go Chain (Cont)



STE/ICE Go/No-Go Chain (Cont)



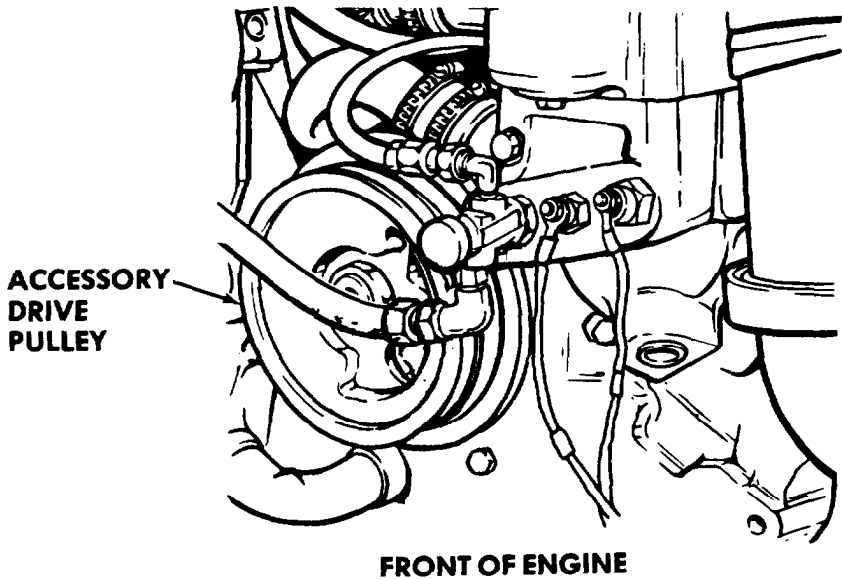
STE/ICE GO/NO-GO CHAIN (CONT)

NG130 ENGINE TIGHTNESS TEST

WARNING
 Shut off fuel supply so that engine will not start (ENGINE STOP switch depressed while cranking).

CHECK ENGINE TIGHTNESS:

- Rotate engine at accessory drive pulley and check for tightness.
- Does engine rotate freely?



YES NO

• Notify DS Maintenance.

• Refer to paragraph 7-8 to replace starter motor.

NOTE
 After completing repair, rerun GO-Chain tests to check that the problem is fixed and that no other problems exist.

Section VI. MAINTENANCE PROCEDURES.

2-17. MAINTENANCE INTRODUCTION.

Instructions in this section provide general procedures to be followed for removal, repair, replacement, or installation of components, and testing authorized at the organizational maintenance level as specified in the Maintenance Allocation Chart (MAC). When a special procedure is used in removal, repair, or installation of a component, the detailed procedure will be in the section covering that component. If no special procedure is required, the following will apply.

2-18. SERVICING.

a. *Lubrication.*

- (1) Lubricate in accordance with LO 9-2320-279-12. Use only lubricants specified.
- (2) Before lubricating equipment, wipe all dirt and grease from lubrication points. Clean all lubrication points after lubrication to prevent accumulation of foreign matter.

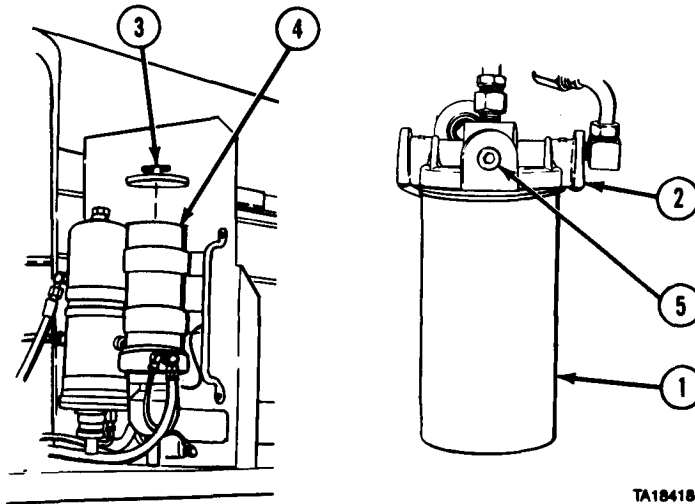
b. *Engine Out of Fuel.*

- (1) In some cases, fuel supply maybe partially removed from the secondary fuel filter before the fuel supply becomes too low to hold engine firing. When the engine has run out of fuel, the following procedures shall be used for restarting the engine:

WARNING

Fuel is flammable and can explode easily. To avoid serious injury or death, keep fuel away from open fire and keep fire extinguisher within easy reach. Do not work on fuel system when engine is hot. Fuel can be ignited by hot engine. Smoking is prohibited while working with fuel.

- (a) Fill fuel tank with diesel fuel (winter or regular grade, Item 26 or 27, Appendix C). If only partial filling of tank is possible, add minimum of 25 gal (95 L) of fuel.



TA184184

- (b) Remove fuel filter (1) from cover (2) and fill the filter with clean diesel fuel.
- (c) Install fuel filter (1) on cover (2).
- (d) Remove lid (3) from fuel filter/water separator (4). Fill filter cylinder with clean diesel fuel until full.
- (e) Replace lid (3) and hand-tighten T-handle.

Maintenance Procedures (Cent)

NOTE

It may be necessary to remove valve rocker cover and loosen fuel pipe nut to bleed trapped air from fuel system. Be sure fuel pipe nut is retightened securely before replacing rocker cover.

- (f) To restart engine, fuel lines must be rid of air to provide adequate fuel for injectors. Remove pipe plug (5) at fuel filter (1). Connect priming pump at pipe plug outlet and prime fuel system. After priming, remove pump and install pipe plug.
- (g) Start engine. Check filters (1 and 4) for leaks.

12-19. GROUND HANDLING.

- a. Towing. Two towing eyes are located at front and two located at rear of vehicle. Each towing eye is designed to withstand a 60,000 lb (27 240 kg) pull at directions up to 450.
- b. **Parking.** Parking brakes are designed to hold vehicle GVW on a minimum of 20% grade, pointing either uphill or downhill per Federal Motor Carrier Safety Regulation 393.41.
- c. **Moving** Instructions. For forward, aft, lateral, and upward movements, vehicle has four tiedown rings and uses the pintle assembly. Refer to TM 9-2320-279-10 for mooring condition and tiedown locations.
- d. Hoisting. Slings assemblies and towing eyes used for hoisting vehicle have lift capacity of 108,000 lb (49 032 kg).

2-20. INSPECTION OF COMPONENTS.

- a. Examine bearings for rusted or pitted balls, races, or separator. Examine balls and races for abrasion, and serious discoloration. The following are conditions for bearing rejection.

NOTE

Nicks or gouges outside race load areas are not cause for rejection unless deep enough to cause bearing binding or misalignment.

- (1) Cuts or grooves parallel to ball or roller rotation.
- (2) Fatigue pits (as opposed to minor machine marks or scratches).
- b. Clean all parts before inspection. Check for defects such as physical distortion, wear, cracks, and pitting.
- c. When removing drain plugs from axle differential and planetary hubs, check amount of sediment on plugs. Accumulations of grit or fine metal particles may indicate actual or potential component failure. A few fine particles are normal. This inspection helps to determine if there are defective parts prior to internal inspection of the component, and to predict degradation of the equipment.
- d. Check all hose surfaces for broken or frayed fabric, breaks caused by sharp kinks, or chafing against other parts of the unit. Inspect metal tubing lines for kinks. Inspect fitting threads for damage. Replace any defective part. Check for leaks after assembly and during initial operation period.
- e. Visually inspect all castings and weldments for cracks.
- f. Inspect all harnesses for chafed or burned insulation. Inspect all terminal connectors for loose connections and broken parts.

Maintenance Procedures (Cont)

2-21. CLEANING PROCEDURES.WARNING

Adhesives, solvents, and sealing compounds can burn easily, can give off harmful vapors, and are harmful to skin and clothing. To avoid injury or death, keep away from open fire and use in well-ventilated area. If adhesive, solvent, or sealing compound gets on skin or clothing, wash immediately with soap and water.

- a. When cleaning ball or roller bearings, place in a basket and suspend in container of dry cleaning solvent, (Item 47, Appendix C). If necessary, use brush to remove caked grease or chips. Avoid rotating bearings before solid particles are removed to prevent damaging races and balls. When bearings have been cleaned, spin immediately in light lubricating oil (Item 30, Appendix C) to remove solvent.
- b. Do not clean preformed packings or other rubber parts in dry cleaning solvent. Wipe clean with clean, dry, lint-free cloth.
- c. Before disassembly of vehicle, clean exterior parts of vehicle thoroughly with dry cleaning solvent (Item 47, Appendix C) to remove accumulated mud, tar, and grease.
- d. For exterior cleaning of frame and structural components, use cleaning compound (Item 12, Appendix C), in a solution as recommended on the container. Leave application on item surface for approximately 10 minutes before rinsing. Rinse with hot or cold water under pressure. If available, use hot water under 80 to 120 lb (36 to 54 kg) pressure. An ordinary garden hose with nozzle may be used if other equipment is not available. Rinse thoroughly. If pressurized water supply is not available, wash painted surfaces of vehicle with solution of 1/4 cup of soap chips (Item 45, Appendix C), to one gallon of water.
- e. Electrical parts such as coils, connectors, switches, and insulated wiring should not be soaked or sprayed with cleaning solutions. Clean these parts with clean, lint-free cloth moistened with dry cleaning solvent (Item 47, Appendix C).

CAUTION

Do not use gasoline, diesel fuel, or other petroleum base products to clean or preserve hydraulic system components. Use of petroleum base products can change the lubricating quality of hydraulic oil and cause failure or damage to equipment.

- f. When cleaning hydraulic system components, use petroleum-free solvents. Clean and dry parts thoroughly to make sure no residue remains. If preservative coating is required before reassembly, apply light film of preservative oil, Military Specification MIL-H-6083D (Item 35, Appendix C). If petroleum-free solvents are not available for cleaning, use hydraulic fluid compatible with that used in the vehicle system.

2-22. PAINTING. Instructions for preparation of material for painting, how to paint, and material to be used are in TM 43-0139. Instructions for camouflage painting are contained in FM 5-20. Stenciling and marking military vehicles are called out in TB 43-0209. Data plates location and description are referenced in para 1-10.

2-23. REMOVAL AND DISASSEMBLY OF COMPONENTS.

- a. Before removal of any electrical component, disconnect battery ground cables (para 7-91).
- b. Ensure that adequate clearance is available for removal of the component. Disassemble the vehicle to the extent necessary to provide adequate working clearance.
- c. Use chain hoist, jack, or other aid when lifting heavier components. Lifting device should be positioned and attached to components to remove all strain from mounting hardware before last hardware is removed.

Maintenance Procedures (Cont)

b. Discard preformed packings, gaskets, seals, and similar material when removed. Be sure that all traces of oil, gaskets, and sealants are removed. When possible, use wood or plastic probes and scrapers to prevent damage to machined surfaces.

e. Cotter pins, lockwashers, lockwire, self-locking nuts, and any similar locking devices should be discarded when removed. Self-locking fasteners that loosen up must be replaced, not tightened.

f. To prevent moisture and foreign matter from entering open housings, lines and other openings, use protective covers as soon as possible after disassembly. Wrap all parts in clean paper or dip parts in preservative oil. Military Specification MIL-C-8188C (Item 36, Appendix C), or equivalent.

g. Remove parts only if repair or replacement is required. Do not disassemble a component any further than necessary to accomplish needed repairs.

2-24. LUBRICATION. Refer to LO 9-2320-279-12 for lubrication procedures and requirements for vehicles covered in this manual. The instructions include types and grades of lubricants used, lube points, locations, and frequency of required lubrication.

2-25. ASSEMBLY.

a. Remove protective grease coatings from new parts before installation.

b. To replace preformed packings, first clean groove, then stretch packing into position. Rotate component on flat surface applying downward pressure to uniformly press packing into position. A light coating of fluid which the packing will operate in will make assembly easier.

c. Coat oil seals evenly with oil or grease before installing. Install oil seals with seal lip facing in, applying an even force to the outer edge of seal. If oil seals are to be installed over keyed or splined shafts, use a guide to prevent sharp edges of the keyway of splines from cutting the seal. Guides can be very thin gage sheet metal shaped to the required diameter. Make certain guide edges are not sharp and are bent slightly inward so they do not cut the seal.

d. Lubricate bearings before reassembly with the type of lubricant normally used in the related housing or container. This will provide lubrication during the first run-in until lubricant from the system can reach the bearings.

e. To ensure good ground connections, clean or grind metal surfaces at connections to remove paint, oxides, corrosion, oils, and/or grease. After connections are completed, apply corrosion preventive compound to connections.

2-26. INSTALLATION. Put hoses, tubes, lines, and electrical wiring in place by matching identification tags, markings on equipment, and using foldouts presented at end of this manual. Use sealing compounds as required in each maintenance task. When installing screws, and nuts, be sure to tighten to values given in Appendix E, Torque Limits or values given in maintenance tasks.

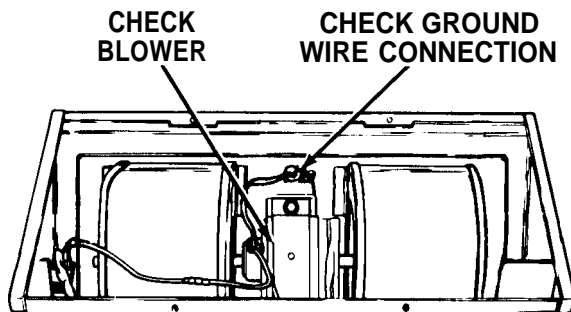
2-27. ADJUSTMENT. Make changes to equipment pressures, settings, and positions only as required in each maintenance task. Adjustments will bring equipment into proper operating condition.

2-28. RADIO INTERFERENCE SUPPRESSION.

a. Radio interference suppression is the elimination or minimizing of electrical disturbances (sparking noises) in the radio caused by the engine and vehicle accessories. Electrical disturbances in vehicles equipped with radios must be suppressed properly to prevent interference with radio transmission and reception. Radio interference in the M977 series vehicles can be caused by improper grounding of the starter, cab heater blower motor, and improper shielding of crane electrical components.

Maintenance Procedures (Cent)

2-28. RADIO INTERFERENCE SUPPRESSION (CONT).



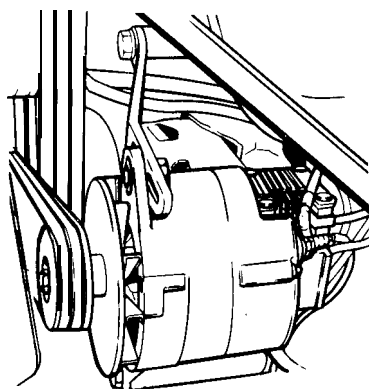
CHECK BLOWER

CHECK GROUND WIRE CONNECTION

TA356999

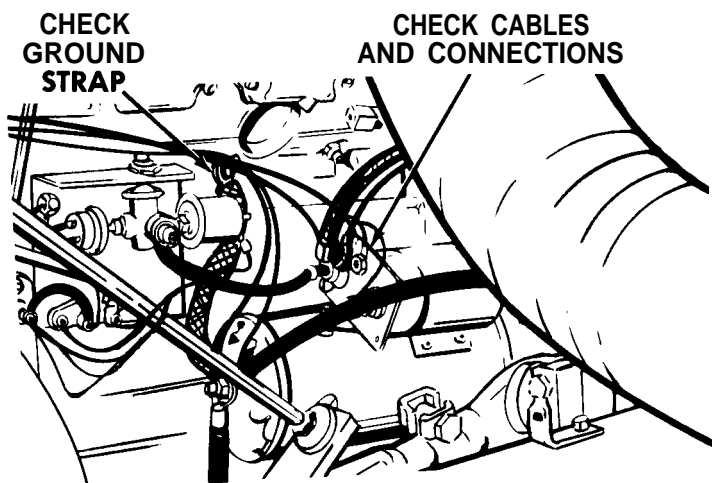
b. Suppression in the M977 series vehicles is accomplished by grounding straps, tooth-type washers, shielded cables, and shielded crane electrical components. Use these suppression devices when necessary to join critical parts, forming a complete electrical circuit, for conducting radio interference currents directly to vehicle ground and away from antennas.

c. Blower motor used in the cab for heating/cooling/air circulation has built-in ground straps for attachment. Tooth-type washers are used whenever an interference suppression ground connection is made.



ALTERNATOR/REGULATOR

TA184830



CHECK GROUND STRAP

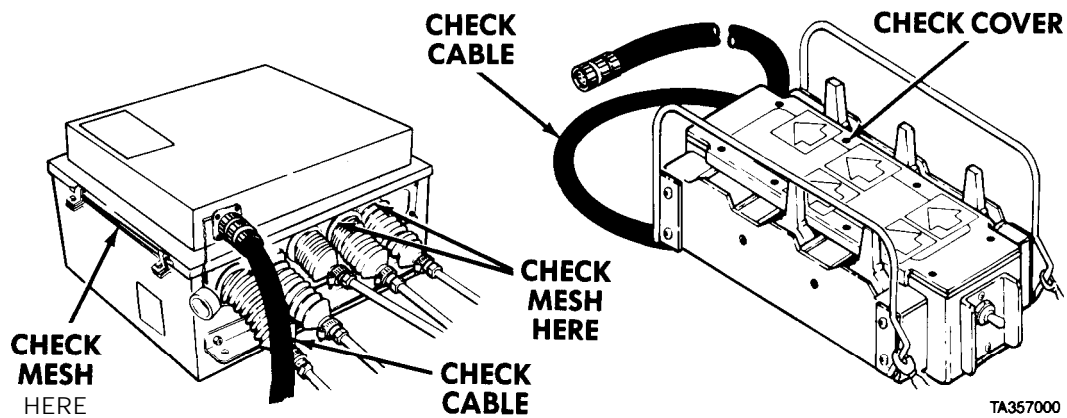
CHECK CABLES AND CONNECTIONS

STARTING MOTOR

TA184831

d. Starting/charging system. The alternator/regulator has built-in interference suppressors to eliminate brush noise. Starting motor ground strap and cables must be in good condition, not frayed or broken, and all nuts securely tightened to ensure positive grounding. Scrape mating metal surfaces clean before installing ground straps and cables.

Maintenance Procedures (Cent)



e. The Electro-Mechanical Proportional Controller (EMPROC), used on M983 model 8001 crane, uses wire mesh shielding around the controller cover and control levers. Be sure the cover is tightly installed, and that mesh is not missing from around control levers. The remote controller unit and cable are shielded. Check that the remote controller cover is secure, that connectors are not broken, and that cable is not frayed or the covering broken. Check all cables around the control unit to be sure none are frayed or covering is broken.

f. The radio interference suppression system maybe tested as follows:

- (1) Bring a radio-equipped vehicle within 25 ft (8 m) of vehicle to be tested. Shut off engine. Turn on radio equipment for maximum sensitivity.
- (2) Turn on radio equipment in test vehicle, if so equipped.
- (3) Start engine of test vehicle and turn on all auxiliary equipment. No increase in background noise in either the vehicle equipment or the nearby vehicle should be heard.
- (4) If noise is heard in radio equipment, turn off auxiliary equipment components one at a time until noise stops. Or, reverse the order and turn on components until noise starts.
- (5) When a component is found which causes radio interference, check carefully for loose electrical connections, loose mountings, missing tooth-type washers, damaged or broken metal housing.
- (6) If interference cannot be eliminated with thorough cleaning and minor repairs, replace the component.
- (7) If radio interference still is present, repeat operation above. More than one component may be causing interference.
- (8) If interference still persists after repeating step (5) above, notify direct support maintenance unit.

2-29. PLACING IN SERVICE.

a. When a new or reconditioned vehicle is first received by the using organization, it is necessary to determine that the vehicle is in satisfactory condition and will operate properly when first placed into service. The service procedures are as follows:

- (1) Visually inspect vehicle upon receipt for obvious damage, such as broken, cracked, dented, or missing parts. Report any damage, in accordance with DA PAM 738-750.
- (2) Refer to Tables 2-1 through 2-6 for the necessary preventive maintenance checks and services, and lubricate per LO 9-2320-279-12.

Section VII. PREPARATION FOR STORAGE OR SHIPMENT

2-30. PREPARATION FOR STORAGE OR SHIPMENT INTRODUCTION

- a. Instructions in this section apply to the vehicle to make it available for use upon receipt after shipment. The storage instructions apply to vehicles being taken out of service for a period up to one year with exercise. If vehicles are inactive for more than one year they will use extended storage procedures.
- b. Instructions pertaining to administrative storage are covered in AR 750-1.
- c. Instructions pertaining to security procedures are covered in TB 9-2300-422-20.
- d. Instructions pertaining to storage and maintenance of prepositioned materiel configured to unit sets are covered in TM 38-450.

2-31. PREPARATION FOR STORAGE OR SHIPMENT.

- a. Perform all Unit Preventive Maintenance Checks and Services (PMCS).
- b. Correct all deficiencies noted during inspection if facilities are available. If repairs required are beyond the scope of Unit Maintenance, refer the deficiencies to Direct or General Support Maintenance.
- c. Instructions pertaining to Basic Issue Items (BII) and Components of End Items (COEI) storage locations are covered in Appendix B of TM 9-2320-279-10.
- d. Remove rust and corrosion, and scrape any flaked and peeling paint. Dry all surfaces to be painted and coated with preservatives. Refer to TM 9-247: Materials Used for Cleaning, Preserving, Abrading, and Cementing Ordnance Material and Related Materials Including Chemicals.
- e. Repaint surface, as required, to prevent against deterioration. Refer to TM 43-0209: Painting Instructions for Field Use, Color, Marking, and Camouflage Painting of Military Vehicles.

2-32.DELETED.

2-33.STORAGE.

- a. Before placing a vehicle in storage, perform the following tasks:
 - (1) Clean the exterior, interior of cab, engine, and undercarriage. Wash any oil, grease, or mud from tires.

WARNING

Do not check tire pressure before referring to TM 9-2320-279-10 for proper tire pressure checking procedure. Personal injury or death could result.

- (2) Conduct a visual inspection of the vehicle. Check lubricant levels and tire pressures. Correct any discrepancies.
- (3) Completely lubricate the chassis and all ancillary equipment in accordance with LO 9-2320-279-12.
- (4) Check the coolant level. Test the coolant to ensure that the cooling system is protected against corrosion and temperatures down to -30°F (-34°C). Add antifreeze or corrosion inhibitors compatible with ethylene glycol base antifreeze if cooling system is not adequately protected (TM 750-651).

Preparation for Storage or Shipment (Cont)

- (5) Ensure the fuel tank contains at least 20 gallons (75.7L) of treated fuel. The fuel should be treated with Biobor JF (MIL-S-53021) or equivalent as a fungus inhibitor. The addition of 3 teaspoons of Biobor JF to 20 gallons of fuel will provide adequate protection against fungus growth. When storing a vehicle in freezing conditions, the addition of 3 ounces (88.7 ml) of isopropyl alcohol (MIL-A-10-428) to 20 gallons of diesel fuel will help prevent fuel line freeze up.
- (6) All fuel that is added to the vehicle during storage must be treated. While in storage, there must always be at least 20 gallons (75.7L) of treated fuel in the vehicle's fuel tank.
- (7) Check condition of engine air cleaner. Service if necessary (para 4-3).
- (8) Coat all exposed unpainted surfaces such as crane valve spools, hydraulic cylinders, axle ball sockets, drive shafts, and shift cables with grease.

CAUTION

Do not allow baking soda to enter the batteries or damage to the batteries will result.

- (9) Clean batteries and battery cables with a baking soda solution and rinse with fresh water. Add water to battery electrolyte if necessary. Check the specific gravity of the batteries regularly. Keep the batteries fully charged and clean (TM 9-6150-200-14).
- (10) Protect spare tire from direct sunlight.
- (11) If possible, store vehicles close together, out of direct sunlight, and away from electrical or generating equipment.
- (12) Park vehicle to allow access for inspection, maintenance, and exercising.

CAUTION

Ensure tires are not resting on surface containing grease or oil. Failure to comply may result in damage to tires.

- (13) Park vehicle so tires are not resting on surfaces containing grease or oil.

CAUTION

The alternator drains the batteries at all times. Batteries will discharge during storage if not disconnected.

- (14) Disconnect batteries (para 7-90).

b. While vehicle is in storage, perform the following tasks monthly:

- (1) Connect batteries (para 7-90).
- (2) If engine is run every 30 days or less, use lubricating oil OE/HDO (MIL-L-2104). If engine is not run every 30 days or less, use preservative lubricating oil (MIL-L-21260C, Grade 2) and change oil filter or warranty will not be maintained (LO 9-2320-279-12).
- (3) Conduct visual inspection of the vehicle. Check for oil leaks, lubricant levels, battery electrolyte, coolant level, and tire pressures. Correct any discrepancies.
- (4) Inspect oil can points. Lubricate if necessary (LO 9-2320-279-12).
- (5) Shift transfer case to neutral, start engine, and idle for 10 minutes. After 10 minutes of engine idle, operate engine for 5 minutes at 1500 rpm or until the engine water temperature reaches 180°F (82°C). Shift the transmission slowly through all gear selector positions. Return the transmission to neutral and the transfer case to high range.
- (6) Move vehicle 30 feet (9 m) forward and reverse.
- (7) Idle engine 10 minutes before shutdown.
- (8) Check grease coating on all chromium plated and unpainted surfaces. If grease was wiped from chromium plated or unpainted surfaces when vehicle was moved, recoat these surfaces.

Preparation for Storage or Shipment (Cont)

2-33. STORAGE (CONT).

- (9) Disconnect batteries (para 7-90). If batteries are not going to be charged for over 30 days, remove batteries from vehicle (TM 9-2320-279-20-1) and keep fully charged (TM 9-6150-200-14).
- c. While vehicle is in storage, perform the following tasks quarterly:
 - (1) Perform all monthly tasks.
 - (2) Exercise all ancillary equipment (TM 9-2320-279-10). While operating winches or crane, lubricate wire rope (LO 9-2320-279-12).
 - (3) Drive vehicle at least 1/4 mile (0.4 km). While driving, shift transmission through all gear ranges.
- d. While vehicle is in storage, perform the following tasks yearly:
 - (1) Perform all quarterly tasks.
 - (2) Clean the exterior, interior of cab, engine, and undercarriage. Wash any oil and grease from tires.

CAUTION

Do not allow the baking soda solution to enter the batteries or damage to the batteries will result.

- (3) Clean batteries and battery cables with a baking soda solution and rinse with fresh water. Add water to battery electrolyte if necessary. Check the specific gravity of the batteries regularly. Keep the batteries fully charged and clean (TM 9-6150-200-14).
 - (4) Completely lubricate the chassis and all ancillary equipment in accordance with LO 9-2320-279-12.
 - (5) Check the coolant level. Test the coolant to ensure that the cooling system is protected against corrosion and temperatures down to -30°F (-34°C). Add antifreeze or corrosion inhibitors compatible with ethylene glycol base antifreeze if cooling system is not adequately protected (TB 750-651).
 - (6) Change engine oil and oil filter. Change fuel filters (LO 9-2320-279-12).
- e. Extended storage (vehicle inactive).

CAUTION

When vehicle is to remain inactive for more than 12 months, extended storage procedures must be performed to prevent damage due to rust, corrosion, or organic growth in the fluids.

NOTE

When vehicle is to remain inactive for more than 12 months, extended storage procedures must be performed to maintain the vehicle warranty.

- (1) Completely lubricate the chassis and all ancillary equipment in accordance with LO 9-2320-279-12.
- (2) Main hydraulic and steering hydraulic systems extended storage for M984A1.

CAUTION

To avoid overfilling, drain an amount of oil equal to amount being added before installing additive or damage to equipment may result.

- (a) Drain amount of oil from main hydraulic reservoir that is equal to the quantity of additive being added.
- (b) Add 9 qt (8.5L) VCI-326 vapor corrosion inhibitor (MIL-P-46002) or equivalent to main hydraulic reservoir.

Preparation for Storage or Shipment (Cont)

- (c) Operate all hydraulic equipment and steering system.
 Model M984A1 HD winch - winch out approximately ten feet of cable, then winch in. Repeat procedure twice.
 Crane - completely cycle each crane function two times.
 Retrieval system - completely extend and retract each cylinder two times.
 Self-recovery winch - winch out approximately six feet of cable, then winch in. Repeat cycle two times.
 Steering system - turn steering wheel to full right turn and then full left turn. Repeat this cycle three times.
- (d) If additional storage time is required, repeat steps (a) and (b) at yearly intervals.
- (3) Main hydraulic and steering hydraulic systems extended storage.
 All models except M984A1.

CAUTION

To avoid overfilling, drain an amount of oil equal to amount being added before installing additive or damage to equipment may result.

- (a) Drain amount of oil from main hydraulic reservoir that is equal to the quantity of additive being added.
- (b) Add 6 qt (5.7L) VCI-326 vapor corrosion inhibitor (MIL-P-46002) or equivalent to main hydraulic reservoir.
- (c) Operate all hydraulic equipment and steering system.
 All models except M984A1
 Crane (if equipped) - completely cycle each crane function two times.
 Self-recovery winch - winch out approximately six feet of cable, then winch in. Repeat cycle two times.

WARNING

Do not operate pump without fuel in tank. Explosion with personal injury or death or damage to equipment may result.

- Tanker - if fuel is in tank, use pump to drain or recirculate fuel for a minimum of one minute. If no fuel is in tank, do not operate pump.
 Steering system - turn steering wheel to full right turn and then full left turn. Repeat this cycle three times.
- (d) If additional storage time is required, repeat steps (a) and (b) at yearly intervals.
- (4) Crane extended storage.
- (a) Coat all unpainted surfaces with corrosion preventative compound (MIL-C-11796) or equivalent.
- (b) Clean and touch up all paint defects to prevent rusting.
- (c) Apply liberal amounts of grease to the solenoid valve button.
- (d) Unwind hoist cable from drum, clean and lube with recommended lubricant (MIL-L-2104), rewind on drum.

CAUTION

To avoid overfilling, drain an amount of oil equal to amount being added before installing additive or damage to equipment may result.

- (e) Add vendor recommended percentage of VCI-326 (MIL-P-46002) or equivalent as a vapor corrosion inhibitor to crane swing drive [2 fl oz, (60 ml)] and hoist gearboxes [0.8 fl oz, (24 ml)]. Operate crane to allow additive to coat all moving parts.

Preparation for Storage or Shipment (Cont)

2-33. STORAGE (CONT).

- (f) If additional storage time is required, repeat step (e) at yearly intervals.
- (5) Self-recovery winch extended storage.
None required.
- (6) Axle extended storage.

CAUTION

To avoid overfilling, drain an amount of oil equal to amount being added before installing additive or damage to equipment may result.

- (a) Drain amount of oil from axle that is equal to quantity of additive being added.
- (b) Add VCI-326 vapor corrosion inhibitor (MIL-P-46002) or equivalent to:
- No. 1 Axle - 1.8 pt (0.8 L) All Models
 - No. 2 Axle - 2.2 pt (1 L) All Models
 - No. 3 Axle - 2.1 pt (1 L) M977, M978, M985, M985E1
 - No. 3 Axle - 2.4 pt (1.2 L) M983
 - No. 3 Axle - 2.2 pt (1 L) M984, M984A1
 - No. 4 Axle - 1.7 pt (0.8 L) M977, M978, M985, M985E1
 - No. 4 Axle - 1.6 pt (0.73 L) M983
 - No. 4 Axle - 1.8 pt (0.85 L) M984
 - No. 4 Axle - 2.2 pt (1.1 L) M984A1
- (c) Drive vehicle approximately 1 mile (1.6 km) to mix additive.
- (d) If additional storage time is required, repeat steps (a) and (b) at yearly intervals.
- (7) Transfer case extended storage.

CAUTION

To avoid overfilling, drain an amount of oil equal to amount being added before installing additive or damage to equipment may result.

- (a) Drain amount of oil from transfer case that is equal to quantity of additive being added.
- (b) Add 0.5 pt (0.25L) VCI-326 vapor corrosion inhibitor (MIL-P-46002) or equivalent to transfer case.
- (c) If vehicle can be driven, drive vehicle approximately 1 mile (1.61 km) to mix additives. If vehicle cannot be driven, shift transfer case to neutral; start engine with parking brakes applied and shift transmission manually through all gear selections.

WARNING

Ensure transfer case is cool before proceeding. Failure to comply may result in injury to personnel.

- (d) When transfer case is cool enough to touch by hand, seal breather with moisture proof tape.
- (e) Coat all exposed unpainted surfaces with preservative grease, such as petrolatum (MIL-C-11796, Grade 2) or equivalent.
- (f) If additional storage time is required, repeat step (b) at yearly intervals.
- (8) Transmission extended storage.
- (a) Drain oil (LO 9-2320-279-12).
- (b) Add 2 quarts (1.9L) of VCI-329 vapor corrosion inhibitor (MIL-P-46002) or equivalent and then fill transmission to operating level with transmission fluid. Add one teaspoon of Biobor JF (MIL-S-53021) or equivalent as a fungus inhibitor to transmission oil.

Preparation for Storage or Shipment (Cont)

- (c) Run the engine for approximately five minutes at 1500 rpm with the transmission in neutral (N).
- (d) Drive the vehicle. Make sure the transmission shifts thru all ranges.
- (e) Continue running the engine at 1500 rpm with the transmission in neutral until normal operating temperature is reached.

CAUTION

Do not allow transmission oil temperature to exceed 225°F (107°C) or damage to transmission may result.

- (f) If normal operating temperature is less than 225°F (107°C) shift the transmission to forward range and stall the converter. Do not exceed 225°F (107°C). Idle engine for approximately five minutes with transmission in neutral (N).

WARNING

Ensure transmission is cool before proceeding. Failure to comply may result in injury to personnel.

- (g) As soon as transmission is cool enough to touch, seal all openings and the breather with moisture-proof tape.
 - (h) Coat all exposed, unpainted surfaces with preservative grease such as petrolatum (MIL-C-11796, Class 2).
 - (i) If additional storage time is required, repeat steps (b) thru (h) at yearly intervals; except, it is not necessary to drain the transmission each year. Just add VCI-329 (MIL-P-46002) or equivalent vapor corrosion inhibitor and Biobor JF (MIL-S-53021) or equivalent as a fungus inhibitor.
- (9) Fuel system extended storage.
- (a) Drain fuel tank.
 - (b) Change all fuel filters.
 - (c) Ensure the fuel tank contains at least 20 gallons (75.7L) of treated fuel. The fuel should be treated with Biobor JF (MIL-S-53021) or equivalent. The addition of 3 teaspoons of Biobor to 20 gallons of fuel will provide adequate protection against fungus growth. When storing a vehicle in freezing conditions, the addition of 3 ounces (88.7 ml) of isopropyl alcohol (MIL-A-10-428) to 20 gallons of diesel fuel will help prevent fuel line freeze up.
 - (d) Run engine 5 minutes to circulate clean treated fuel throughout the fuel system.
 - (e) All fuel that is added to the vehicle during storage must be treated. While in storage, there must always be at least 20 gallons (75.7L) of treated fuel in the vehicle's fuel tank.
 - (f) Cap off fuel system.
- (10) Engine extended storage.
- (a) Change oil and filter (LO 9-2320-279-12). Add preservative lubricating oil (MIL-L-21260C, Grade 2).
 - (b) Seal off turbocharger inlet and outlet connections with moisture resistant tape.
- (11) Battery extended storage (more than 30 days with no charging). Remove batteries from vehicle (para 7-90) and keep fully charged (TM 9-6150-200-14).
- (12) Check the coolant level. Test the coolant to ensure that the cooling system is protected against corrosion and temperatures down to -30°F (-34°C). Add antifreeze or corrosion inhibitors compatible with ethylene glycol base antifreeze if cooling system is not adequately protected (TB 750-651).

Preparation for Storage or Shipment (Cont)

2-33. STORAGE (CONT).

f. When removing vehicle from storage, perform the following tasks:

- (1) Install batteries (para 7-90).

WARNING

Do not check tire pressure before referring to TM 9-2320-279-10 for proper tire pressure checking procedure. Personal injury or death could result.

- (2) Conduct a visual inspection of the vehicle and remove moisture proof tape from engine, transmission, transfer case and fuel system. Check lubricant levels and tire pressures. Correct any discrepancies.
- (3) Lubricate the chassis, ancillary equipment, and oil can points (LO 9-2320-279-12).

CHAPTER 3
ENGINE MAINTENANCE

| | | |
|--|------|------|
| Contents | Para | Page |
| General | 3-1 | 3-1 |
| Engine Block Cooling System Draincock Removal/Installation | 3-2 | 3-1 |
| Rocker Cover and Gasket Removal/Installation | 3-3 | 3-4 |
| Engine Oil Filter Removal/Repair/Installation | 3-4 | 3-8 |
| Engine Oil Filter Adapter Removal/Repair/Installation | 3-5 | 3-10 |
| Oil Cooler Inlet Elbow and Flange Elbow Removal/Installation | 3-6 | 3-12 |
| Oil Cooler Housing Removal/Installation | 3-7 | 3-17 |
| Engine Oil Sampling Valve and Fittings Removal/Installation | 3-8 | 3-22 |

Section I. INTRODUCTION

3-1. GENERAL. This chapter contains maintenance instructions for removing, installing, replacing, and servicing the engine components authorized by the Maintenance Allocation Chart (MAC) at the organizational maintenance level.

Section II. ENGINE ASSEMBLY

Engine Maintenance Instructions

3-2. ENGINE BLOCK COOLING SYSTEM DRAINCOCK REMOVAL/INSTALLATION.

This task covers:

| | |
|--|--|
| <ul style="list-style-type: none"> a. Removal — Right Side Cooling System Draincock b. Installation — Right Side Cooling System Draincock c. Removal — Front Cooling System Draincock d. Installation — Front Cooling System Draincock | <ul style="list-style-type: none"> e. Removal — Left Side Cooling System Draincock f. Installation — Left Side Cooling System Draincock g. Removal - Radiator Draincock h. Installation - Radiator Draincock i. Follow-on Maintenance |
|--|--|

INITIAL SETUP

| | | | | | | | |
|---|--|-------------------|------------------------------|------------------|------------------|----------|-------------------------|
| <p><i>Models</i> All</p> <p><i>Test Equipment</i> None</p> <p><i>Special Tools</i> None</p> <p><i>Supplies</i> Compound, sealing, pipe thread, Item 18, Appendix C</p> <p><i>Personnel Required</i> MOS 63S, Heavy wheel vehicle mechanic</p> | <p><i>References</i> None</p> <p><i>Equipment Condition</i></p> <table border="0" style="width: 100%;"> <tr> <td style="width: 30%;"><i>TM or Para</i></td> <td style="width: 70%;"><i>Condition Description</i></td> </tr> <tr> <td>TM 9-2320-279-10</td> <td>Shut off engine.</td> </tr> <tr> <td>Para 6-2</td> <td>Cooling system drained.</td> </tr> </table> <p><i>Special Environmental Conditions</i> None</p> <p><i>General Safety Instructions</i> None</p> | <i>TM or Para</i> | <i>Condition Description</i> | TM 9-2320-279-10 | Shut off engine. | Para 6-2 | Cooling system drained. |
| <i>TM or Para</i> | <i>Condition Description</i> | | | | | | |
| TM 9-2320-279-10 | Shut off engine. | | | | | | |
| Para 6-2 | Cooling system drained. | | | | | | |

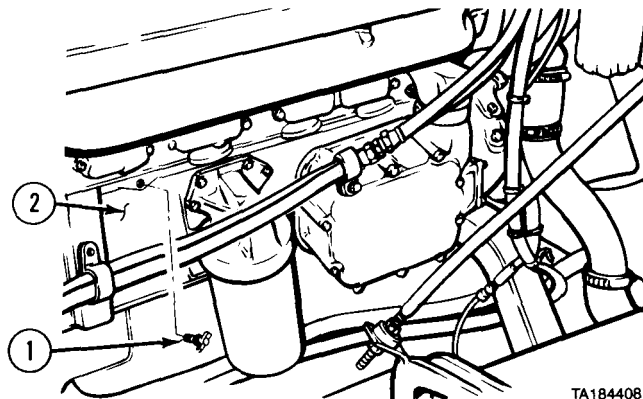
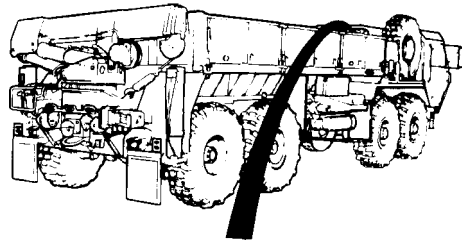
3-2. ENGINE BLOCK COOLING SYSTEM DRAINCOCK REMOVAL/INSTALLATION (CONT).

a. Removal — **Right** Side Cooling System **Draincock**. Remove draincock (1) from engine block (2).

WARNING

Adhesives, solvents, and sealing compounds can burn easily, can give off harmful vapors, and are harmful to skin and clothing. To avoid injury or death, keep away from open fire and use in well-ventilated area. If adhesive, solvent, or sealing compound gets on skin or clothing, wash immediately with soap and water.

b. Installation — **Right** Side Cooling System **Draincock**. Coat threads with pipe thread sealing compound, and install draincock (1) in engine block (2).



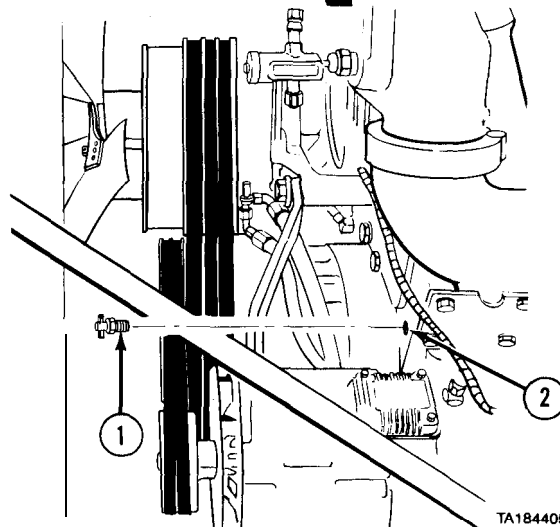
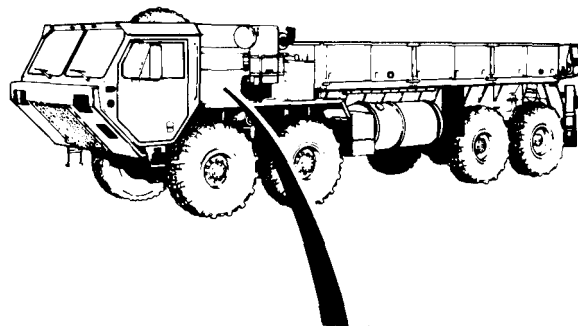
TA184408

c. Removal — Front **Cooling** System **Draincock**. Remove draincock (1) from engine block (2).

WARNING

Adhesives, solvents, and sealing compounds can burn easily, can give off harmful vapors, and are harmful to skin and clothing. To avoid injury or death, keep away from open fire and use in well-ventilated area. If adhesive, solvent, or sealing compound gets on skin or clothing, wash immediately with soap and water.

d. Installation - Front Cooling System **Draincock**. Coat threads with pipe thread sealing compound and install draincock (1) in engine block (2).



TA184405

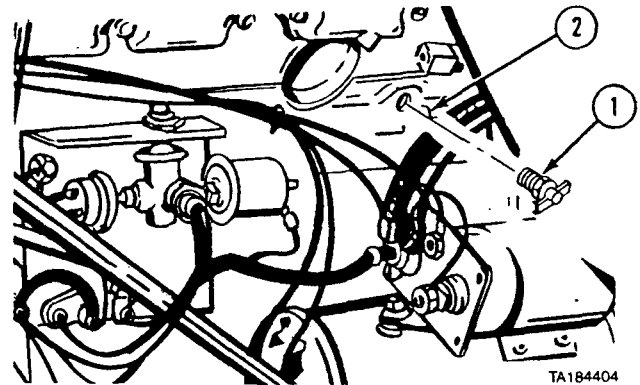
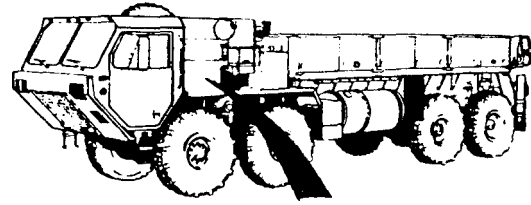
Engine Maintenance Instructions (Cent)

e. Removal — Left Side Cooling **System Drain cock**. Remove draincock (1) from engine block (2).

WARNING

Adhesives, solvents, and sealing compounds can burn easily, can give off harmful vapors, and are harmful to skin and clothing. To avoid injury or death, keep away from open fire and use in well-ventilated area. If adhesive, solvent, or sealing compound gets on skin or clothing, wash immediately with soap and water.

f. Installation - Left Side Cooling **System Drain cock**. Coat threads with pipe thread sealing compound and install draincock (1 in engine block (2).



TA184404

g. Removal — Radiator **Draincock**. Remove draincock (1) from radiator (2).

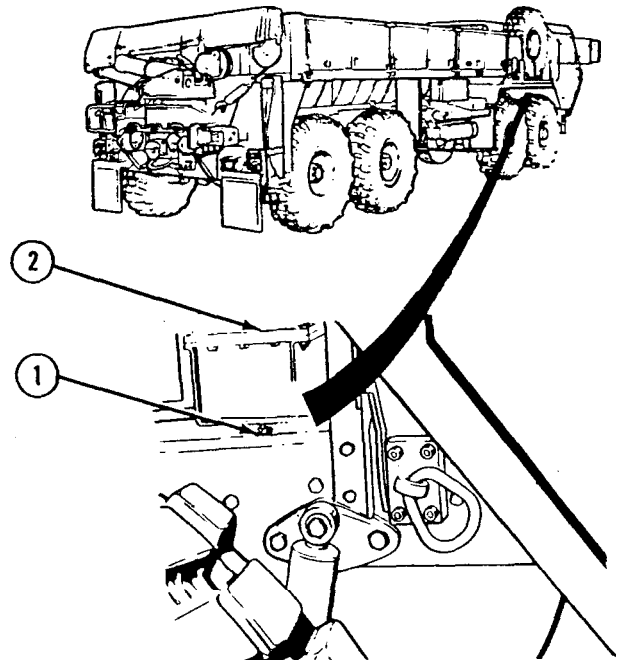
WARNING

Adhesives, solvents, and sealing compounds can burn easily, can give off harmful vapors, and are harmful to skin and clothing. To avoid injury or death, keep away from open fire and use in well-ventilated area. If adhesive, solvent, or sealing compound gets on skin or clothing, wash immediately with soap and water.

h. Installation — Radiator **Draincock**. Coat threads with pipe thread sealing compound and install draincock (1) in radiator (2).

i. **Follow-on** Maintenance. Fill cooling system (para 6-2).

END OF TASK



1A 185456

Engine Maintenance Instructions (Cent)

3-3. ROCKER COVER AND GASKET **REMOVAL/INSTALLATION.**

This task covers:

- a. Removal
- b. Installation

c. Follow-on Maintenance

INITIAL SETUP

Models

All

Test Equipment

None

Special Tools

None

Supplies

Oil lubricating, Item 33. Appendix C

Personnel Required

MOS 63S, Heavy wheel vehicle mechanic

References

one

Equipment Condition

TM or Para

TM 9-2320-279-10

Condition Description

Shut off engine.

Engine cool.

Para 16-9

Engine cover removed.

Para 4-4

Air intake ducting removed.
(Left side only).

Para 5-2

Exhaust pipe removed.
(Right side only).

Special Environmental Conditions

None

General Safety Instructions

None

a. Removal.

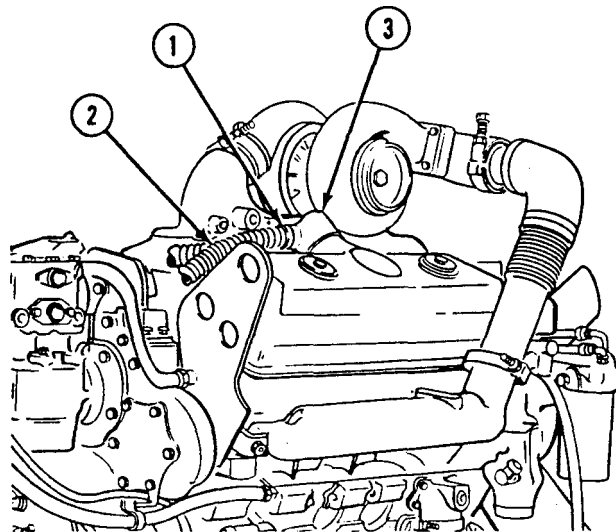
CAUTION

Clean around rocker cover before removing each cover from engine. This will keep dust or dirt from entering cylinder heads.

NOTE

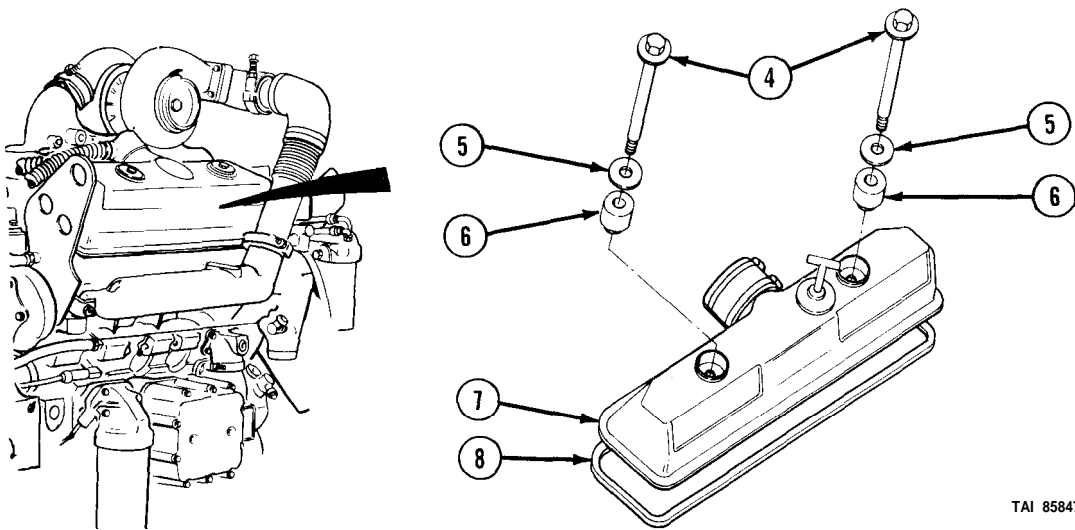
There are two kinds of breather hoses. Model A is a metal hose that uses a U-bolt type clamp. Model B is a rubber hose and uses a worm gear type clamp. If a Model A hose must be replaced by a Model B hose, clamp must be changed also.

- (1) Remove clamps (1) and hoses (2) from breather housing (3).



TA1 82132

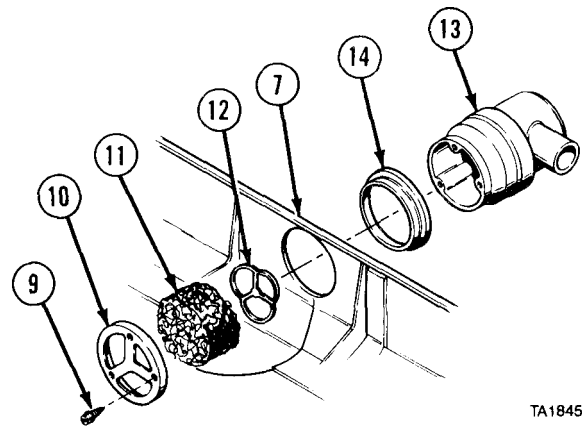
Engine Maintenance Instructions [Cent]



TAI 85847

- (2) Remove screws (4), washers (5), and isolators (6) from rocker cover (7).
- (3) Remove rocker cover (7).
- (4) Remove gasket (8) from rocker cover (7).

- (5) Remove three screws (9) and remove retaining plate (10) from rocker cover (7).
- (6) Remove element (11) and retainer (12) from shell (13).
- (7) Remove shell (13) and seal (14) from rocker cover (7).

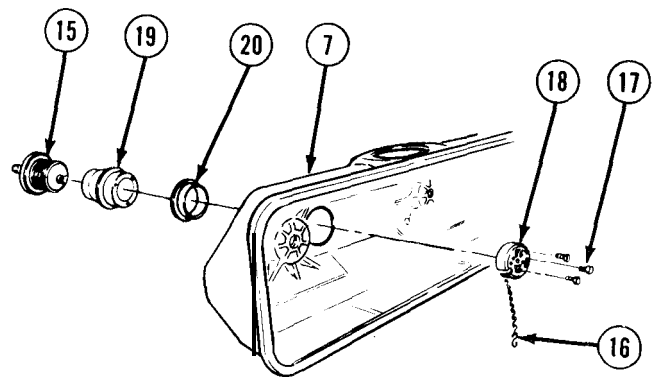


TA184556

NOTE

Fill plug located on left side only,

- (8) Remove filler cap plug (15) and remove chain hook (16) from filler cap plug.
- (9) Remove three screws (17) from strainer (18).
- (10) Remove strainer (18), filler cap tube (19), and seal (20) from rocker cover (7).



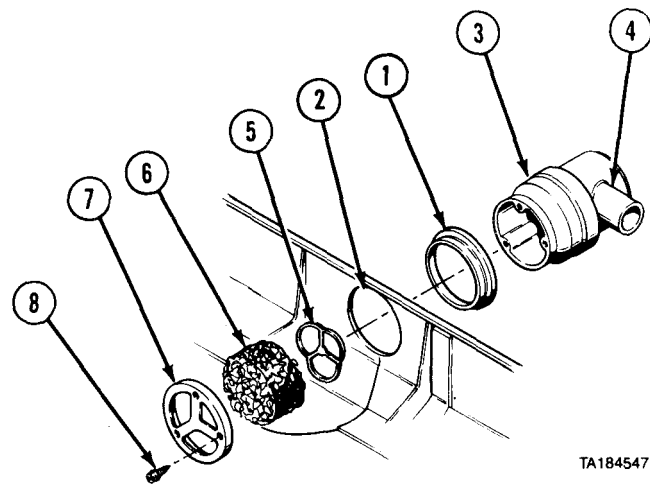
TAI 84557

Engine Maintenance Instructions (Cont)

3-3. ROCKER COVER AND GASKET REMOVAL/INSTALLATION (CONT).

b. Installation.

- (1) Install seal (1) in rocker cover (2).
- (2) Install shell (3) in seal (1) with breather tube stub (4) toward rear of engine.
- (3) Install retainer (5) and element (6) in shell (3).
- (4) Place retainer plate (7) over element (6) and install three screws (8).

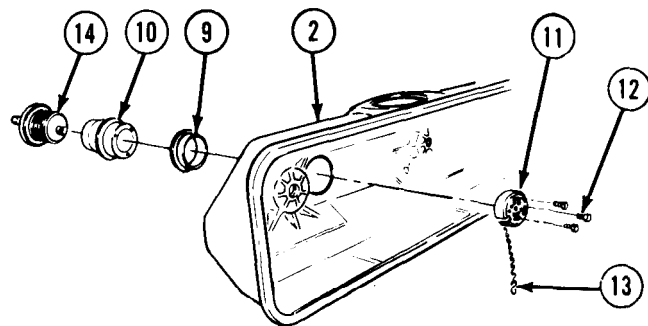


TA184547

NOTE

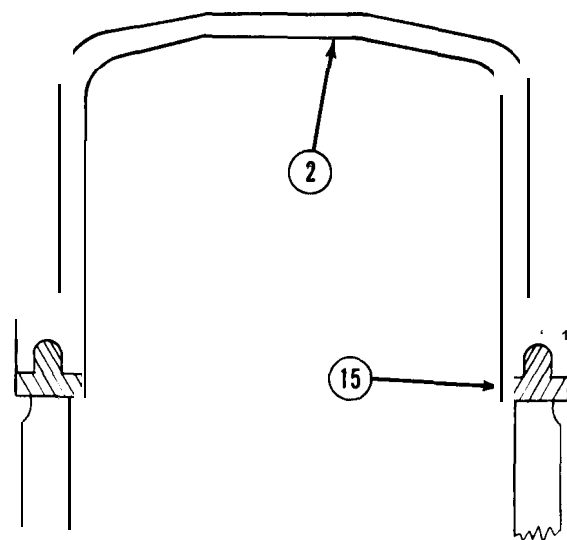
Fill plug located on left side only.

- (5) Install seal (9), filler cap tube (10), and strainer (11) in rocker cover (2). Secure with three screws (12).
- (6) Install chain hook (13) to filler cap plug (14).
- (7) Install filler cap plug (14).



TA1 84546

- (8) Install gasket (15) into groove of rocker cover (2).
- (9) Install rocker cover (2) on engine.



TA1 84558

Engine Maintenance Instructions (Cent)

NOTE

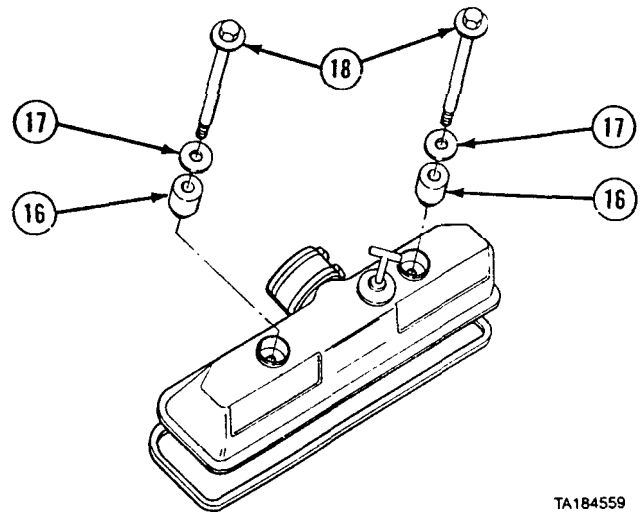
Front screw for right side rocker cover is shorter than other three.

- (10) Install isolator (16), washer (17), and screws (18). Tighten screws to 15 to 20 lb-ft (20.3 to 27 N·m).

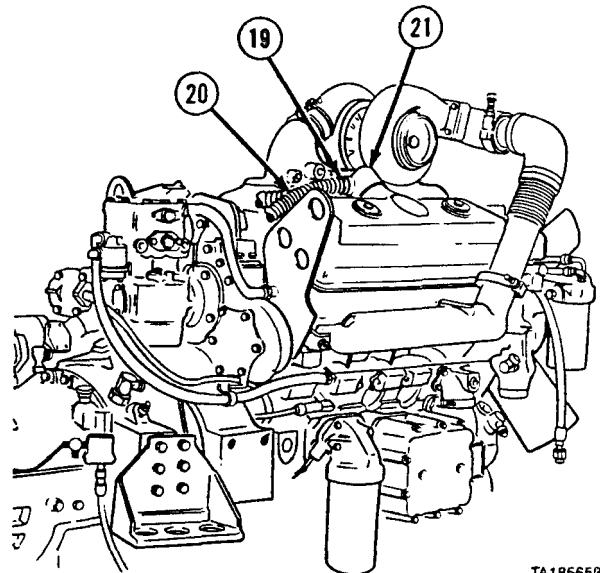
NOTE

There are two kinds of breather hoses. Model A is a metal hose that uses a U-bolt type clamp. Model B is a rubber hose and uses a worm gear type clamp. If a Model A hose must be replaced by a Model B hose, clamp must be changed also.

- (11) Install clamps (19) on hoses (20). Connect hose to each breather housing (21). Tighten clamps.



TA184559



TA185658

c. Follow-on Maintenance.

- (1) Install exhaust pipe (para 5-2). (Right side only.)
- (2) Install intake air ducting (para 4-4). (Left side-only.)
- (3) Start engine and check for leaks around rocker cover gasket (TM 9-2320-279-1 O).
- (4) Shut off engine (TM 9-2320-279-10).
- (5) Install engine cover (pm-a 16-9).

END OF TASK

Engine Maintenance Instructions (Cont)

Section III. ENGINE LUBRICATION SYSTEMS

3-4. ENGINE OIL FILTER REMOVAL/REPAIR/INSTALLATION.

This task covers:

- a. Removal
- b. Disassembly
- c. Assembly
- d. Installation
- e. Follow-on Maintenance

INITIAL SETUP

Models

All

Test Equipment

None

Special Tools

None

Supplies

Oil, lubricating, Item 33, Appendix C

Personnel Required

MOS 63S, Heavy wheel vehicle mechanic

References

None

Equipment Condition

TM or Para

Condition Description

- | | |
|------------------|-----------------------------------|
| TM 9-2320-279-10 | Shut off engine. |
| TM 9-2320-279-10 | Engine cover open. |
| TM 9-2320-279-10 | Engine side panel removed. |
| Para 16-13 | Right front splash guard removed. |
| LO 9-2320-279-12 | Engine oil drained. |

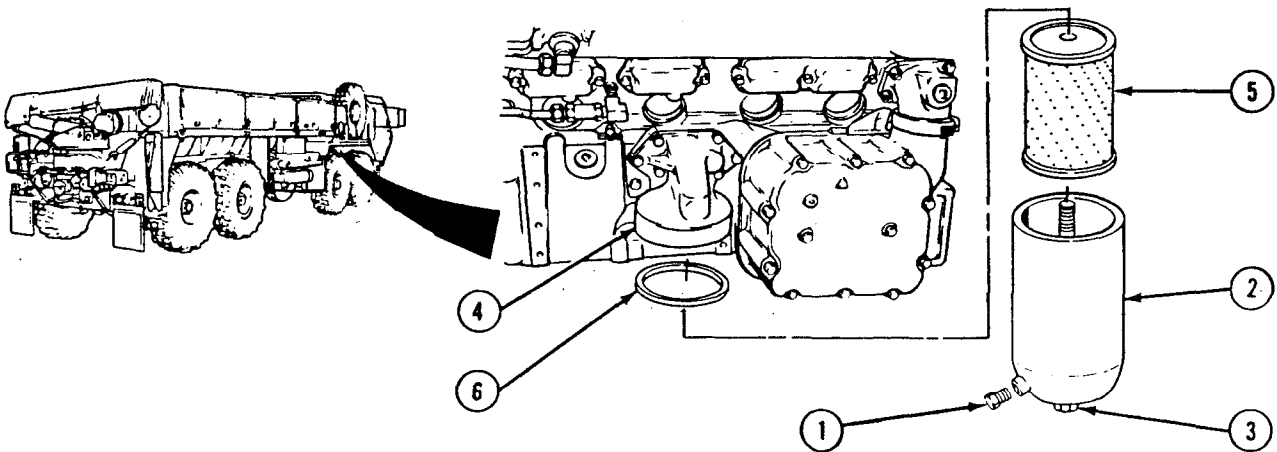
Special Environmental Conditions

None

General Safety Instructions

None

a. Removal.



NOTE

Put suitable container under oil filter shell.

- (1) Remove plug (1) and drain oil from shell (2).
- (2) Loosen center stud (3) and pull shell (2) from adapter (4).
- (3) Remove element (5) from shell (2).
- (4) Remove gasket (6) from adapter (4).

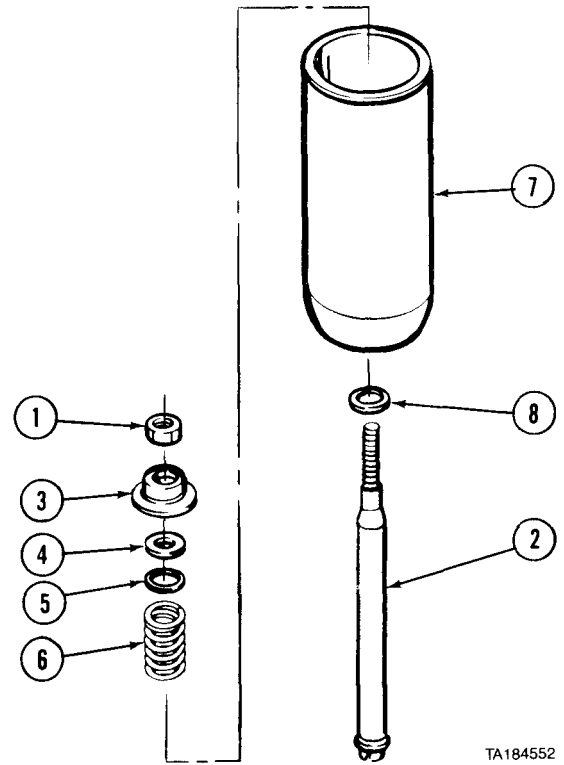
Engine Maintenance Instructions (Cont)

b. Disassembly.

- (1) Remove nut (1) from stud (2).
- (2) Remove retainer (3), seal (4), washer (5), and spring (6) from stud (2).
- (3) Remove stud (2) from shell (7).
Remove gasket (8) from stud (2).

c. Assembly.

- (1) Install gasket (8) on stud (2).
- (2) Install stud (2) in shell (7).
- (3) Install spring (6), washer (5), seal (4), retainer (3), and nut (1) on stud (2).

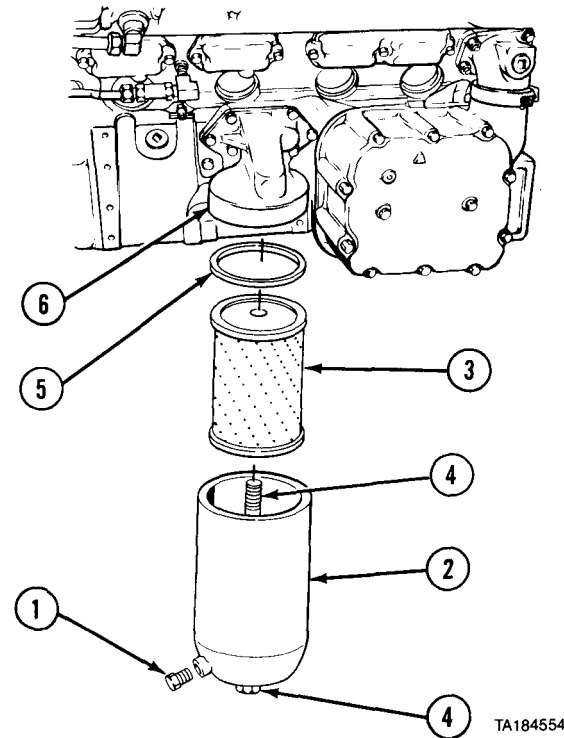


d. Installation.

- (1) Install plug (1) in shell (2).
- (2) Place new element (3) over stud (4) in shell (2).
- (3) Coat gasket (5) lightly with lubricating oil.
- (4) Install gasket (5) in adapter (6).
- (5) Install shell (2) in adapter (6).
- (6) Tighten stud (4) to 50 to 60 lb-ft (68 to 81 N·m).

e. Follow-on Maintenance.

- (1) Fill engine crankcase with oil (LO 9-2320-279-12).
- (2) Install engine side panel (TM 9-2320-279-10).
- (3) Close engine cover (TM 9-2320-279-10).
- (4) Install right front splash guard (para 16-13).
- (5) Start engine and check for oil leaks (TM 9-2320-279-10).



END OF TASK

Engine Maintenance Instructions (Cont)

3-5. ENGINE OIL FILTER ADAPTER REMOVAL/REPAIR/INSTALLATION.

This task covers:

- a. Removal
- b. Disassembly
- c. Assembly
- d. Installation
- e. Follow-on Maintenance

INITIAL SETUP

Models

All

Test Equipment

None

Special Tools

None

Supplies

None

Personnel Required

MOS 63S, Heavy wheel vehicle mechanic

References

None

Equipment Condition

TM or Para

Condition Description

TM 9-2320-279-10

Shut off engine.

TM 9-2320-279-10

Engine cover open.

TM 9-2320-279-10

Engine side panel removed.

Para 3-4

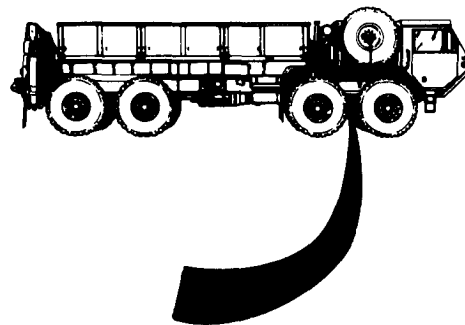
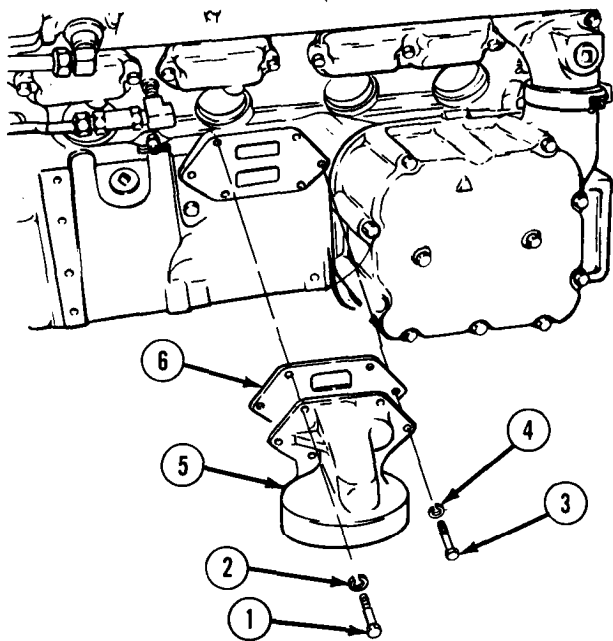
Engine oil filter removed.

Special Environmental Conditions

None

General Safety Instructions

None



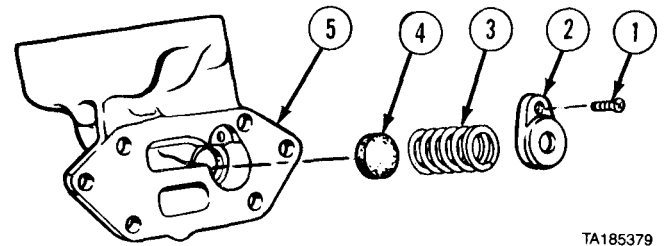
TA185378

a. *Removal.* Remove four screws (1), lockwashers (2), two screws (3), lockwashers (4), oil filter adapter (5), and gasket (6).

Engine Maintenance Instruction (Cont)

b. *Disassembly.* Remove screw (1), retainer (2), spring (3), and piston (4) from oil filter adapter (5).

c. *Assembly.* Install piston (4), spring (3), retainer (2), and screw (1) in oil filter adapter (5).



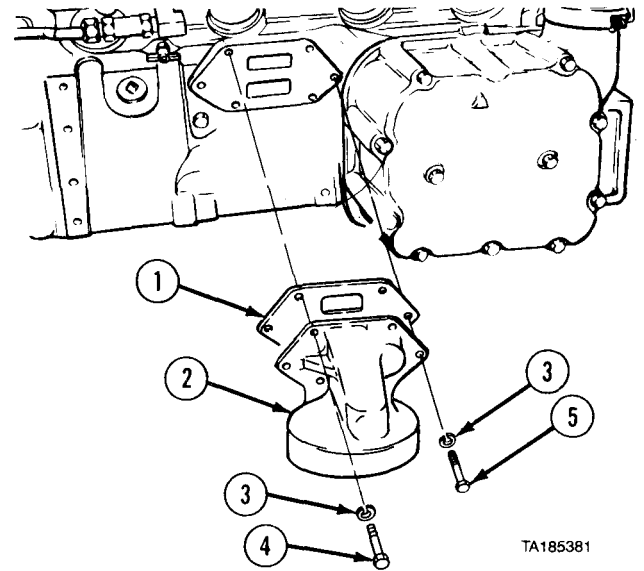
TA185379

d. *Installation.* Install gasket (1), oil filter adapter (2), six lockwashers (3), four screws (4), and two screws (5).

e. *Follow-on Maintenance.*

- (1) Install engine oil filter (para 3-4).
- (2) Install engine side panel (TM 9-2320-279-10).
- (3) Close engine cover (TM 9-2320-279-10).
- (4) Start engine and check for oil leaks (TM 9-2320-279-10).
- (5) Shut off engine (TM 9-2320-279-10).

END OF TASK



TA185381

Engine Maintenance Instructions (Cont)

3-6. OIL COOLER INLET ELBOW AND FLANGE ELBOW REMOVAL/INSTALLATION.

This task covers:

- a. Removal
- b. Installation
- c. Follow-on Maintenance

INITIAL SETUP

Models

All

Test Equipment

None

Special Tools

None

Supplies

Compound, sealing, pipe thread, Item 18, Appendix C

Personnel Required

MOS 63S, Heavy wheel vehicle mechanic

References

None

Equipment Condition

| <i>TM or Para</i> | <i>Condition Description</i> |
|-------------------|------------------------------|
| TM 9-2320-279-10 | Shut off engine. |
| TM 9-2320-279-10 | Engine cover open. |
| TM 9-2320-279-10 | Engine side panel removed. |
| Para 6-2 | Cooling system drained. |

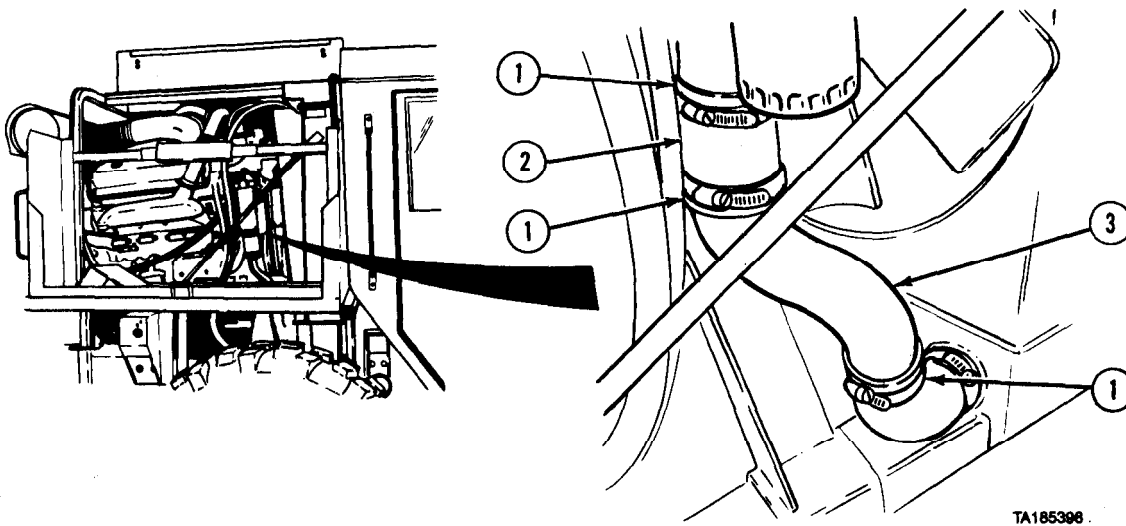
Special Environmental Conditions

None

General Safety Instructions

None

a. Removal.

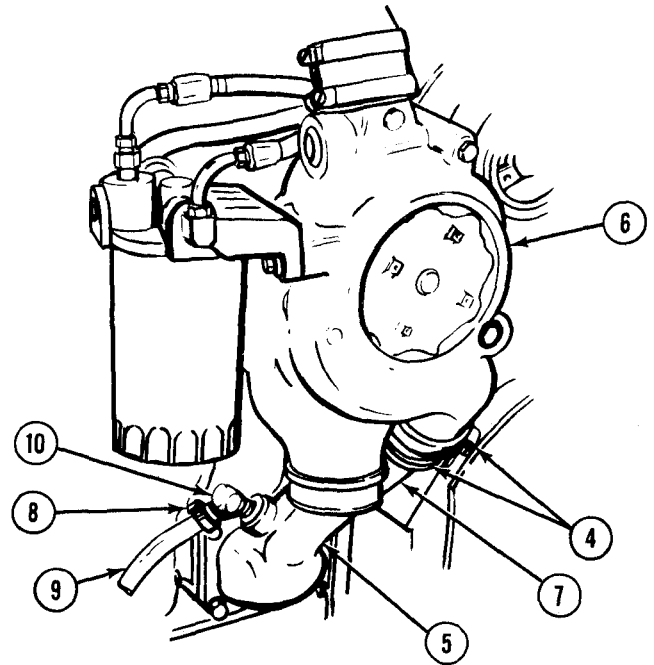


- (1) Loosen three clamps (1).
- (2) Move hose (2) and tube (3) out of way.

TA185398

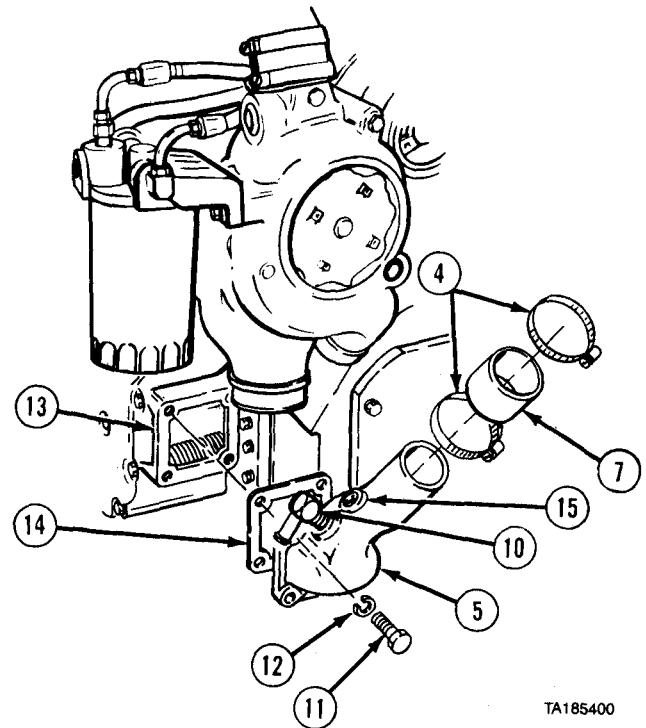
Engine Maintenance Instructions (Cont)

- (3) Loosen two hose clamps (4) on oil cooler inlet elbow (5), and water pump (6).
- (4) Slide clamps (4) and hose (7) down onto oil cooler inlet elbow (5).
- (5) Loosen hose clamp (8), and disconnect hose (9) from fitting (10).



TA185399

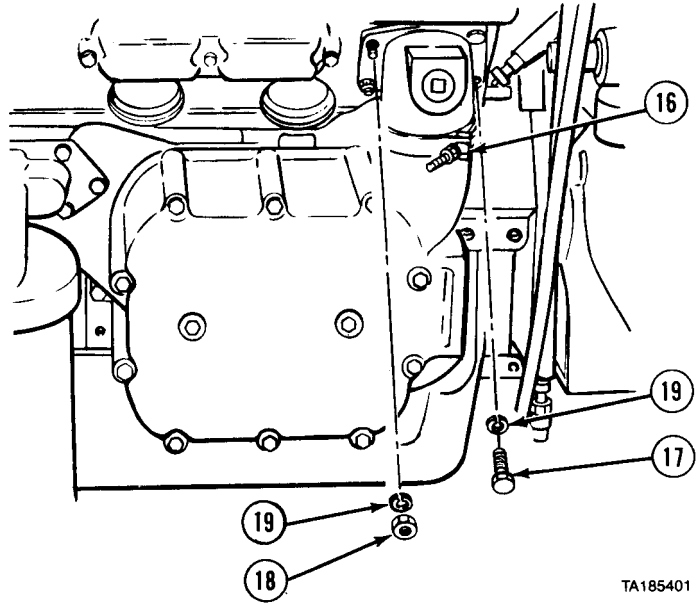
- (6) Remove four screws (11) and lockwashers (12) to detach oil cooler inlet elbow (5) from oil cooler (13).
- (7) Remove oil cooler inlet elbow (5) and gasket (14) from oil cooler (13).
- (8) Remove hose (7) and two clamps (4).
- (9) Remove fitting (10) and plug (15).



TA185400

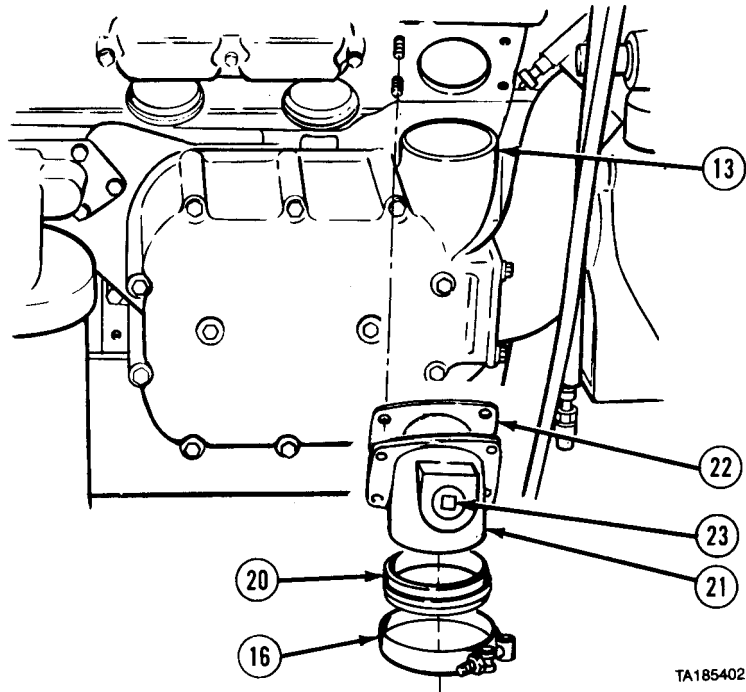
Engine Maintenance Instructions (Cont)

- (10) Loosen clamp (16).
- (11) Remove two screws (17), two nuts (18), and four lockwashers (19).



TA185401

- (12) Slide clamp (16) and seal (20) down on oil cooler (13).
- (13) Remove flange elbow (21), clamp (16), seal (20), and gasket (22).
- (14) Remove plug (23).

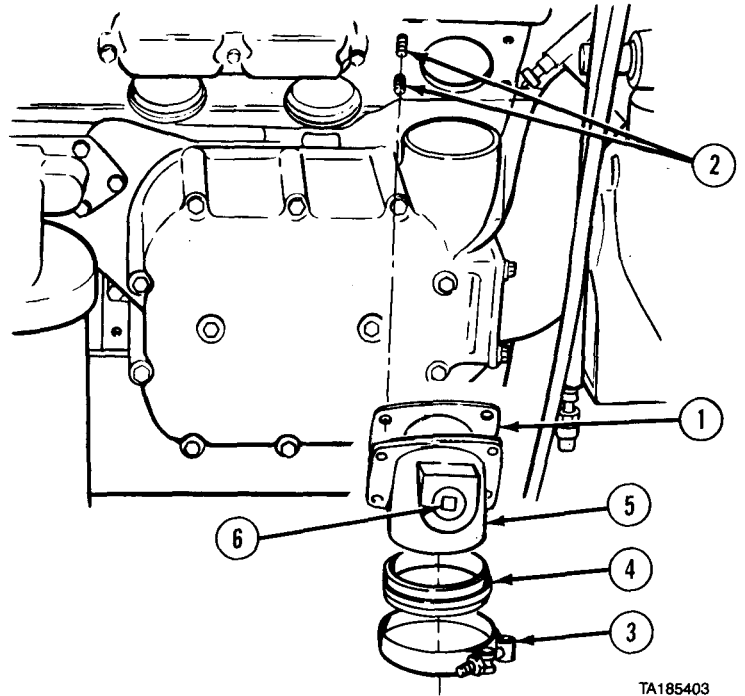


TA185402

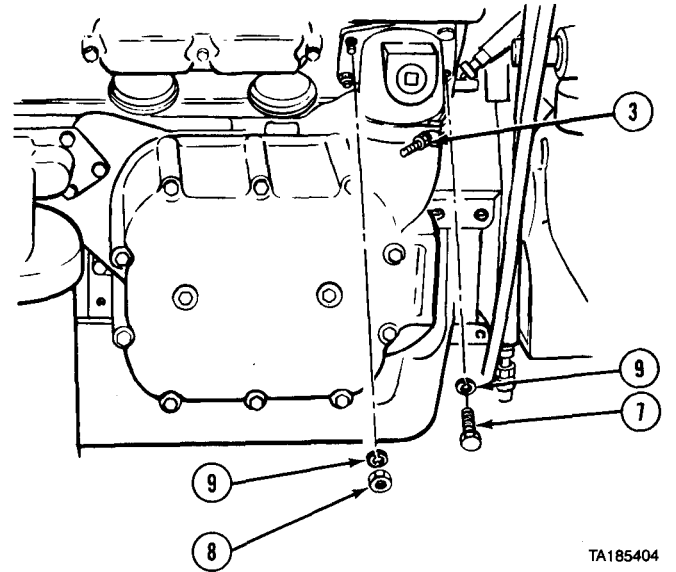
Engine Maintenance Instructions (Cont)

b. Installation.

- (1) Place gasket (1) over studs (2).
- (2) Install clamp (3), seal (4), and flange elbow (5).
- (3) Install plug (6).



- (4) Install two screws (7), two nuts (8), and four lockwashers (9).
- (5) Tighten clamp (3).



Engine Maintenance Instructions (Cont)

**3-6. OIL COOLER INLET ELBOW AND FLANGE ELBOW
REMOVAL/INSTALLATION (CONT).**

CAUTION

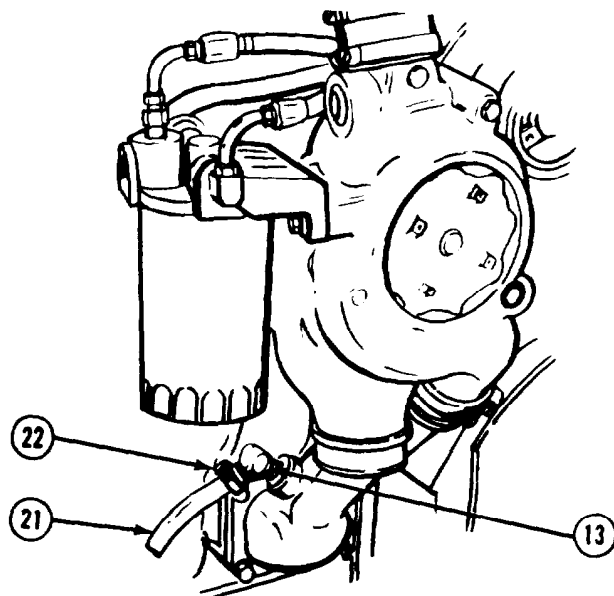
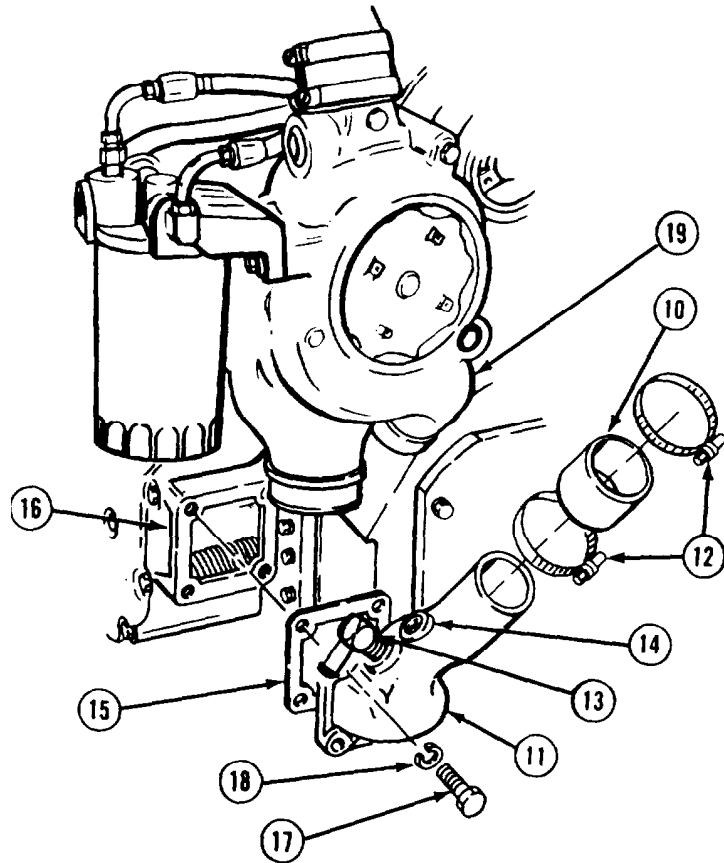
When replacing hose or hose clamps with new parts, hose and clamps must be replaced.

- (6) Install hose (10) on oil cooler inlet elbow (11).
- (7) Slip hose clamps (12) over hose (10). Tighten constant torque clamps to 100 in-lb (11.3 N•m).

WARNING

Adhesives, solvents, and sealing compounds can burn easily, can give off harmful vapors, and are harmful to skin and clothing. To avoid injury or death, keep away from open fire and use in well-ventilated area. If adhesive, solvent, or sealing compound gets on skin or clothing, wash immediately with soap and water.

- (8) Coat threads of fittings (13) and plug (14) with pipe thread sealing compound and install on oil cooler inlet elbow (11).
- (9) Install gasket (15), and oil cooler inlet elbow (11) on oil cooler (16) with four screws (17), and lockwashers (18).
- (10) Install hose (10) to water pump (19).
- (11) Tighten clamps (12).
- (12) Install hose (21) on fitting (13) and tighten clamp (22).

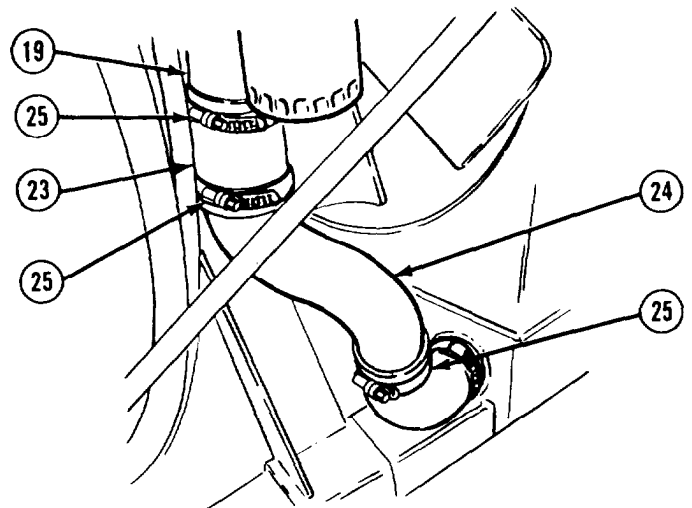


Engine Maintenance Instructions (Cont)

CAUTION

When replacing hose or hose clamps with new parts, hose and clamps must be replaced.

- (13) Position hose (23) and tube (24) on water pump (19) and tighten three clamps (25). Tighten constant torque clamps to 100 in-lb (11.3 N•m).



c. Follow-on Maintenance.

- (1) Refill cooling system (para 6-2).
- (2) Start engine and check for leaks (TM 9-2320-279-10).
- (3) Shut off engine (TM 9-2320-279-10).
- (4) Install engine side panel (TM 9-2320-279-10).
- (5) Close engine cover (TM 9-2320-279-10).

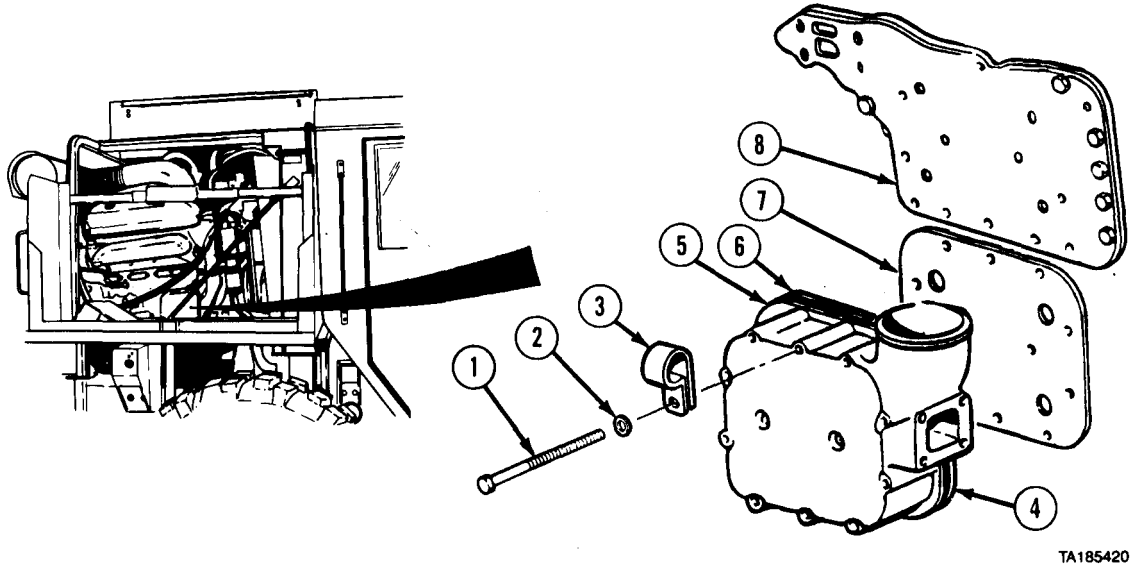
END OF TASK

| 3-7. OIL COOLER HOUSING REMOVAL/INSTALLATION | |
|---|--|
| This task covers: | |
| a. Removal | c. Follow-on Maintenance |
| b. Installation | |
| INITIAL SETUP | |
| <i>Models</i> | <i>Equipment Condition</i> |
| All | TM or Para <i>Condition Description</i> |
| | TM 9-2320-279-10 Shut off engine. |
| <i>Test Equipment</i> | TM 9-2320-279-10 Engine cover open. |
| None | TM 9-2320-279-10 Engine side panel removed. |
| <i>Special Tools</i> | Para 6-2 Cooling system drained. |
| None | Para 3-5 Oil filter adapter removed. |
| | Para 3-6 Oil cooler inlet elbow and flange elbow removed. |
| <i>Supplies</i> | <i>Special Environmental Conditions</i> |
| Grease, automotive and artillery, Item 23, Appendix C | None |
| <i>Personnel Required</i> | <i>General Safely Instructions</i> |
| MOS 63S, Heavy wheel vehicle mechanic | None |
| <i>References</i> | |
| None | |

Engine Maintenance Instructions (Cont)

3-7. OIL COOLER HOUSING REMOVAL/INSTALLATION (CONT).

a. Removal.

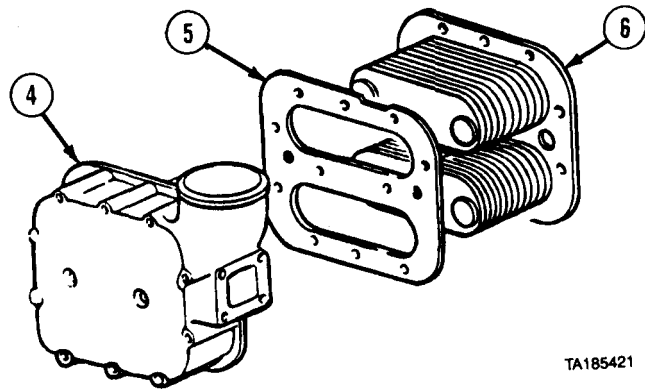


TA185420

NOTE

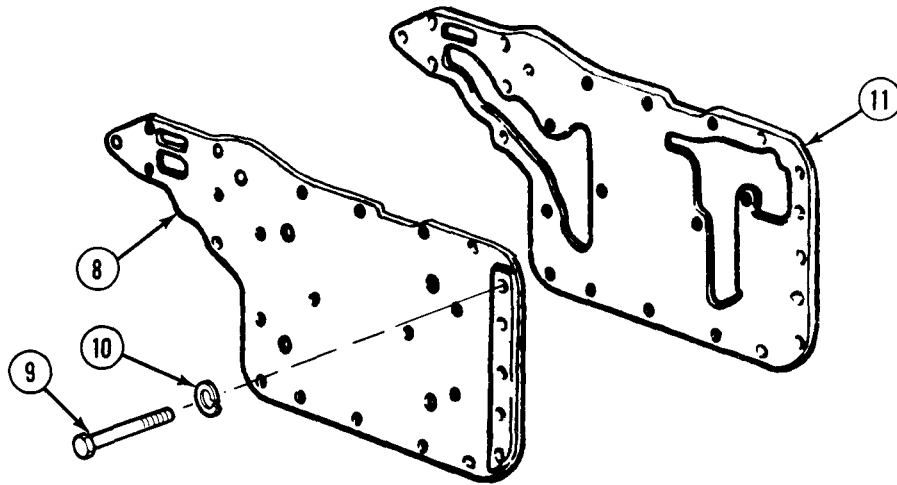
Place a suitable container under oil cooler housing.

- (1) Remove 12 mounting screws (1), lockwashers (2), hose clamp (3), oil cooler housing (4), gasket (5), and core (6).
- (2) Remove gasket (7) from cover plate (8).
- (3) Separate core (6) and gasket (5) from oil cooler housing (4).



TA185421

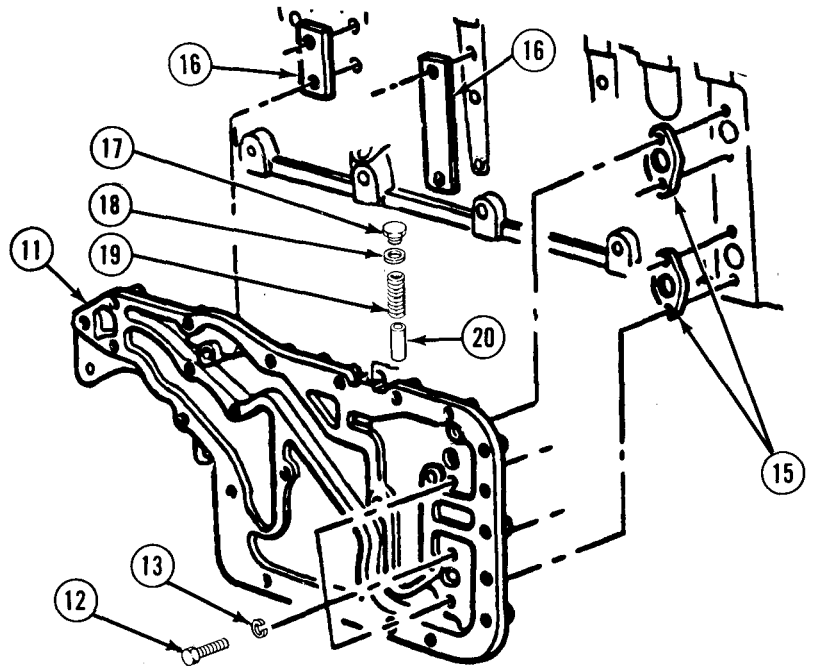
Engine Maintenance Instructions (Cont)



TA185422

- (4) Remove eight screws (9) and lockwashers (10) from cover plate (8).
- (5) Remove cover plate (8) and gasket (11).

- (6) Remove six screws (12) and lockwashers (13).
- (7) Remove adapter (11), two gaskets (15), and two spacers (16).
- (8) Remove plug (17), gasket (18), spring (19), and valve (20).



TA185423

Engine Maintenance Instructions (Cont)

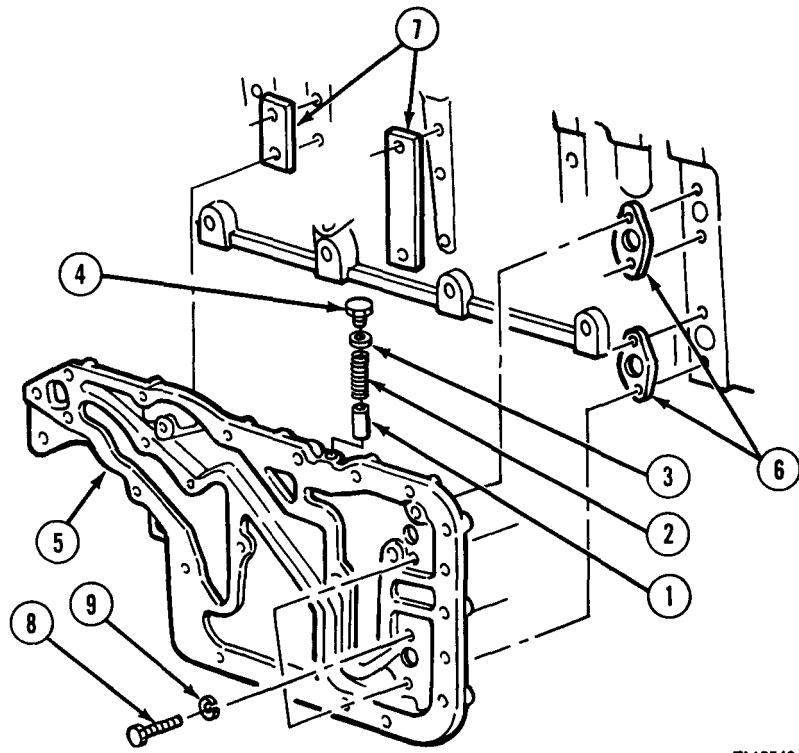
3-7. OIL COOLER HOUSING REMOVAL/INSTALLATION (CONT).

b. Installation.

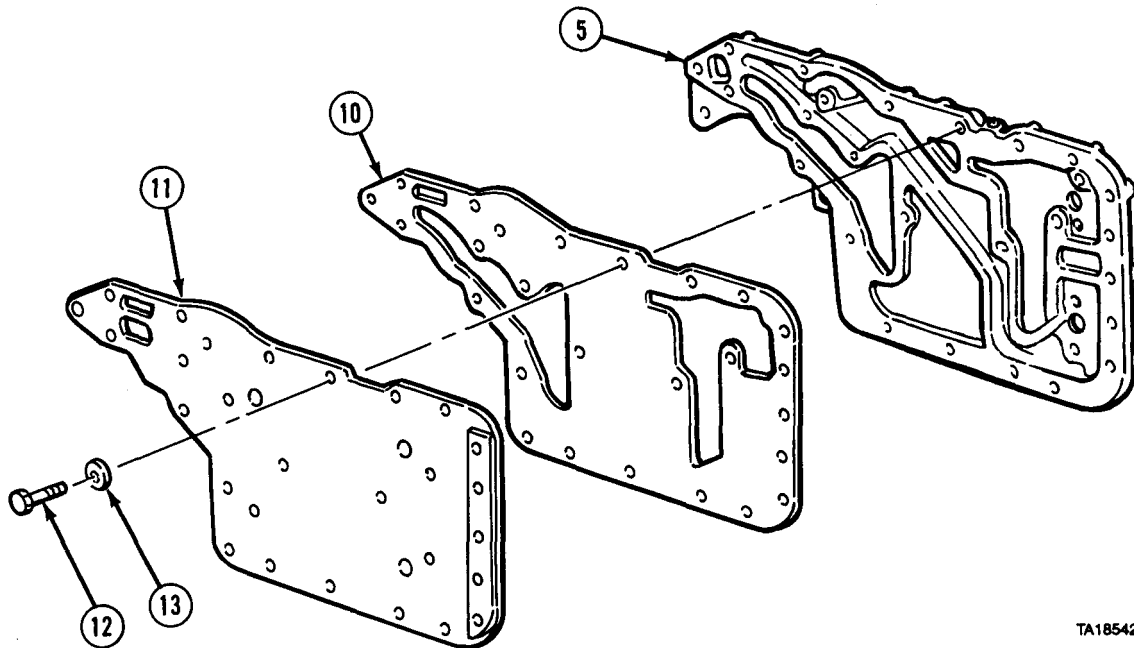
NOTE

Apply grease to all gaskets before installation.

- (1) Install valve (1), open end up, spring (2), gasket (3), and plug (4) in adapter (5). Tighten plug to 30 lb-ft (41 N·m).
- (2) Install two gaskets (6), two spacers (7), and adapter (5).
- (3) Install six screws (8) and lockwashers (9). Tighten screws to 30 to 35 lb-ft (41 to 47 N·m).



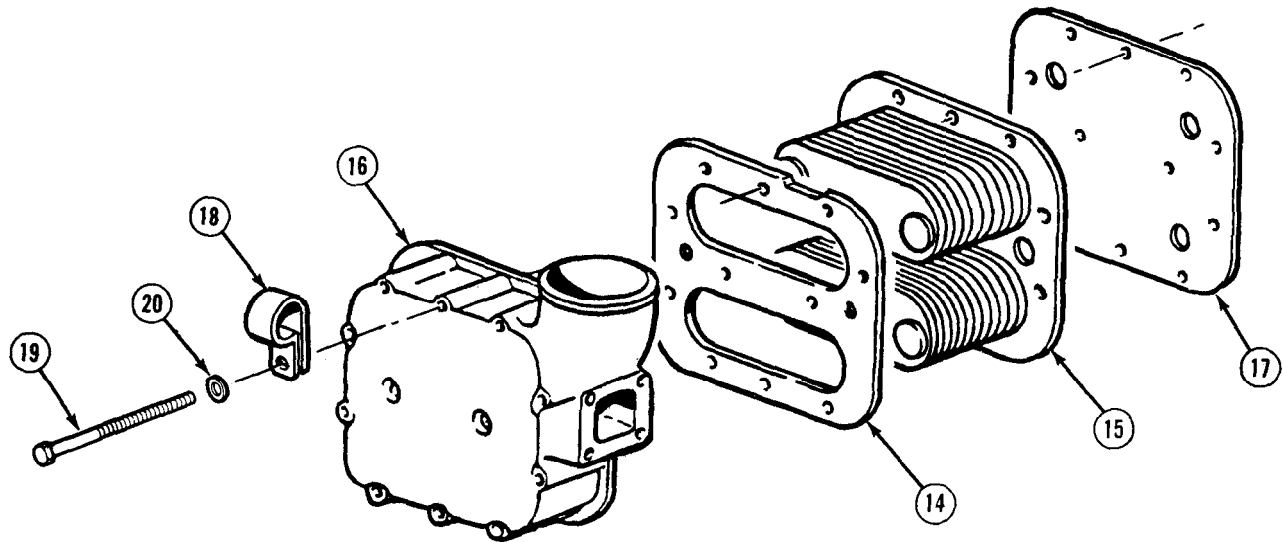
TA185424



TA185425

- (4) Install gasket (10) and cover plate (11) to adapter (5).
- (5) Install eight screws (12) and lockwashers (13). Tighten screws to 25 lb-ft (33 N·m).

Engine Maintenance Instructions (Cont)



TA185426

- (6) Install gasket (14) on core (15). Install core in oil cooler housing (16).
- (7) Install gasket (17).
- (8) Install oil cooler housing (16), hose clamp (18), 12 screws (19), and lockwashers (20). Tighten screws to 10 to 15 lb-ft (13 to 20 N·m).

c. *Follow-on Maintenance.*

- (1) Install oil filter adapter (para 3-5).
- (2) Install oil cooler inlet elbow and flange elbow (para 3-6).
- (3) Fill cooling system with coolant (para 6-2).
- (4) Start engine and check for leaks (TM 9-2320-279-10).
- (5) Shut off engine (TM 9-2320-279-10).
- (6) Install engine side panel (TM 9-2320-279-10).
- (7) Close engine cover (TM 9-2320-279-10).
- (8) Check engine oil (TM 9-2320-279-10).

END OF TASK

Engine Maintenance Instructions (Cont)

3-8. ENGINE OIL SAMPLING VALVE AND FITTINGS REMOVAL/INSTALLATION.

This task covers:

- a. Engine Oil Sampling Valve and Fittings Removal
- b. Engine Oil Sampling Valve and Fittings Installation
- c. Follow-on Maintenance

INITIAL SETUP

Models

All

Test Equipment

None

Special Tools

None

Supplies

Compound, sealing, pipe thread, Item **18**, Appendix C

Personnel Required

MOS 63S, Heavy wheel vehicle mechanic

References

None

Equipment Condition

| TM or Para | Condition Description |
|------------------|---------------------------------|
| TM 9-2320-279-10 | Left side engine panel removed. |

Special Environmental Conditions

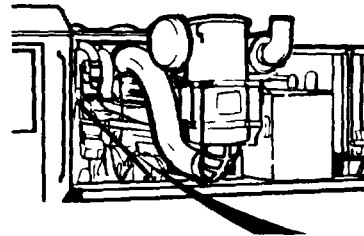
None

General Safety Instructions

None

NOTE

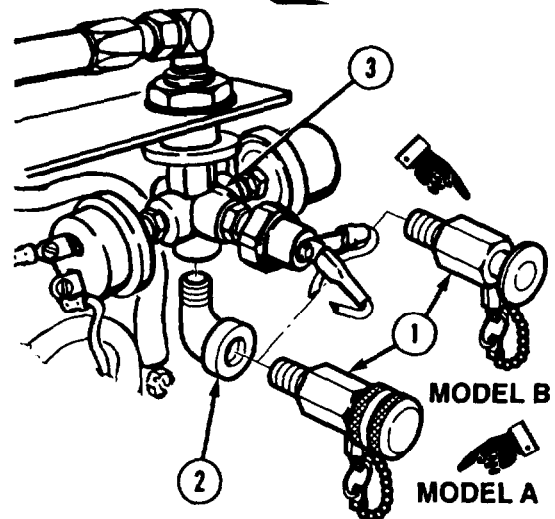
There are two kinds of sampling valves. Both are removed and installed the same way.



- a. **Engine Oil Sampling Valves and Fittings Removal.** Remove valve (1) and elbow (2) from oil sending unit (3).

WARNING

Adhesives, solvents, and sealing compounds can burn easily, can give off harmful vapors, and are harmful to skin and clothing. To avoid injury or death, keep away from open fire and use in well-ventilated area. If adhesive, solvent, or sealing compound gets on skin or clothing, wash immediately with soap and water.



- b. **Engine Oil Sampling Valve and Fittings Installation.** Apply pipe thread sealing compound and install elbow (2) and valve (1) in oil sending unit (3).

- c. **Follow-on Maintenance.** Install left side engine panel (TM 9-2320-279-10).

END OF TASK

CHAPTER 4
FUEL SYSTEM MAINTENANCE

| | Para | Page |
|---|------|------|
| Contents | | |
| General | 4-1 | 4-1 |
| Air Restriction Indicator Removal/Installation | 4-2 | 4-2 |
| Air Filter Element Removal/Service/Installation | 4-3 | 4-3 |
| Air Intake Ducting Removal/Installation | 4-4 | 4-8 |
| Air Cleaner Assembly Removal/Installation | 4-5 | 4-11 |
| Fuel Line and Air Vent Line Removal/Installation | 4-6 | 4-16 |
| Fuel Tank and Brackets Removal/Installation | 4-7 | 4-24 |
| Engine Stop Solenoid Adjustment | 4-8 | 4-31 |
| Fuel-Water Separator Service | 4-9 | 4-32 |
| Fuel-Water Separator Removal/Repair/Installation | 4-10 | 4-33 |
| Secondary Fuel Filter Removal/Installation | 4-11 | 4-41 |
| Ether Starting Aid Removal/Installation | 4-12 | 4-43 |
| Throttle Treadle Valve Testing | 4-13 | 4-47 |
| Throttle Treadle Valve Removal/Installation | 4-14 | 4-48 |
| ENGINE HIGH IDLE Pressure Regulator and Solenoid Removal/Repair/Installation/Adjustment (M984) | 4-15 | 4-51 |
| Throttle Air Solenoid Check Valve Removal/Installation(M984) | 4-16 | 4-55 |

Section I. INTRODUCTION

4-1. GENERAL. This chapter contains maintenance instructions for removing, replacing, installing, repairing, and testing the fuel system components authorized by the Maintenance Allocation Chart (MAC) at the organizational maintenance level.

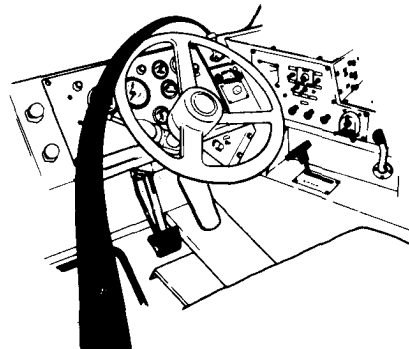


Section II. AIR CLEANER

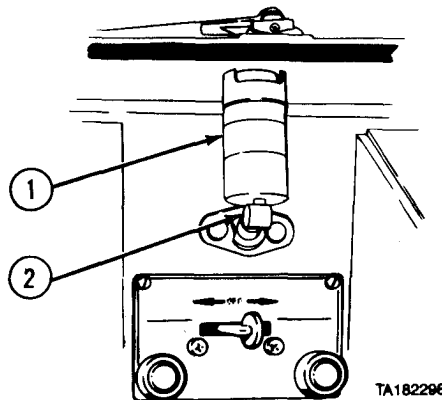
Fuel System Maintenance Instructions

| 4-2. AIR RESTRICTION INDICATOR REMOVAL/INSTALLATION. | |
|--|--|
| This task covers: | |
| a. Removal b. Installation | c. Follow-on Maintenance |
| INITIAL SETUP | |
| <i>Models</i> All | <i>References</i> None |
| <i>Test Equipment</i> None | <i>Equipment Condition</i> <i>TM or Para</i> <i>Condition Description</i> TM 9-2320-279-10 Shut off engine. |
| <i>Special Tools</i> None | <i>Special Environmental Conditions</i> None |
| <i>Supplies</i> None | <i>General Safety Instructions</i> None |
| <i>Personnel Required</i> MOS 63S, Heavy wheel vehicle mechanic | |

- a. *Removal.* Turn restriction indicator (1) counterclockwise and remove from flange mounting (2).
- b. *Installation.* Install restriction indicator (1) on flange mounting (2).
- c. *Follow-on Maintenance.*
 - (1) Start engine (TM 9-2320-279-10).
 - (2) Check operation of restriction indicator (TM 9-2320-279-10).
 - (3) Shut off engine (TM 9-2320-279-10).



END OF TASK



TA182298

Fuel System Maintenance Instructions (Cont)

4-3. AIR FILTER ELEMENT REMOVAL/SERVICE/INSTALLATION.

This task covers:

- | | |
|------------|--------------------------|
| a. Removal | c. Installation |
| b. Service | d. Follow-on Maintenance |

INITIAL SETUP

Models

All

Test Equipment

None

Special Tools

None

Supplies

Adhesive No. 4500, Item 1, Appendix C
 Detergent, painted surface, Item 20,
 Appendix C

Personnel Required

MOS 63S, Heavy wheel vehicle mechanic

References

None

Equipment Condition

| | |
|-------------------|------------------------------|
| <i>TM or Para</i> | <i>Condition Description</i> |
| TM 9-2320-279-10 | Shut off engine. |

Special Environmental Conditions

None

General Safety Instructions

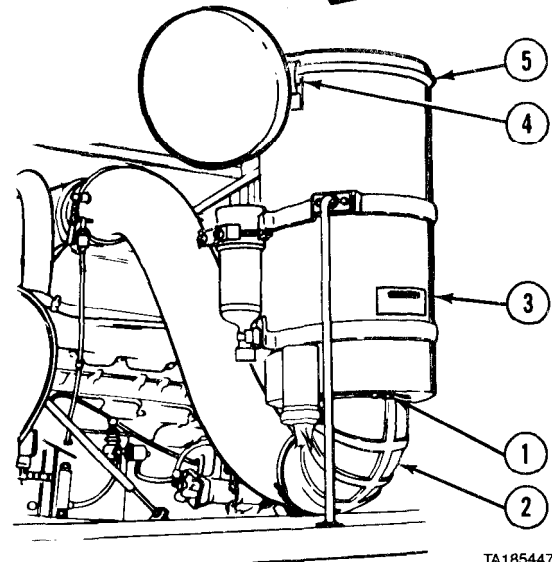
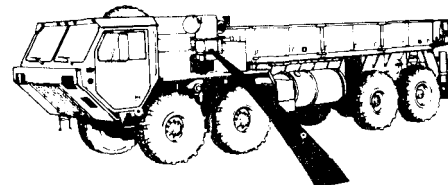
None

a. Removal.

CAUTION

Do not start engine after air intake elbow is removed from air cleaner or equipment damage could result.

- (1) Remove clamp (1).
- (2) Disconnect elbow (2) and tilt away from air cleaner (3).
- (3) Release three latches (4) and remove top cover (5).

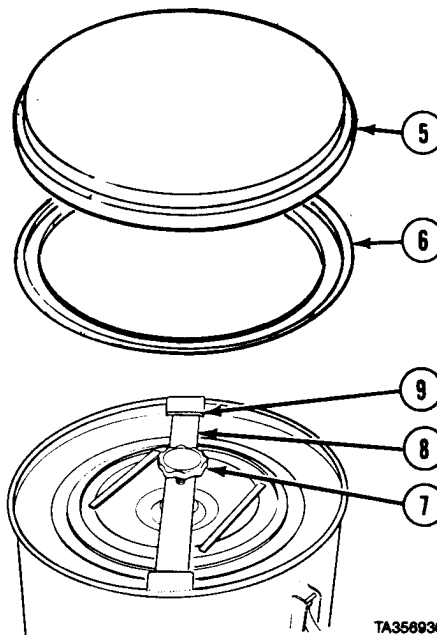


TA185447

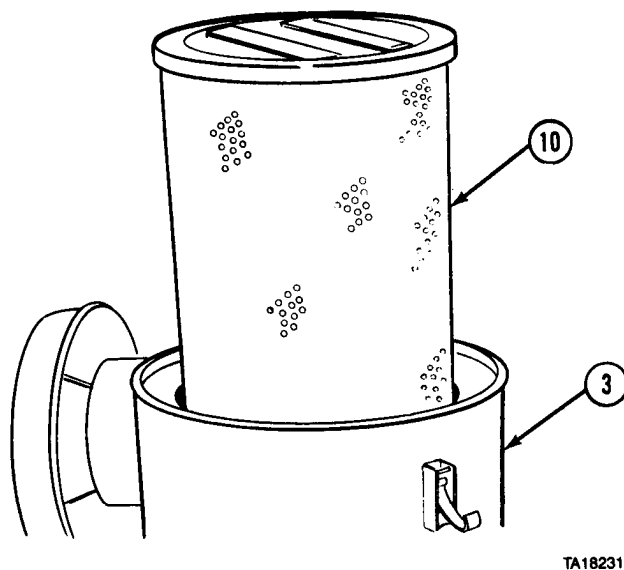
Fuel System Maintenance Instructions (Cont)

4-3. AIR FILTER ELEMENT REMOVAL/SERVICE/INSTALLATION (CONT).

- (4) Remove gasket (6) from top cover (5), if necessary.
- (5) Turn knob (7) counterclockwise. Slide retainer bar (8) clear of clips (9) and remove retainer bar.

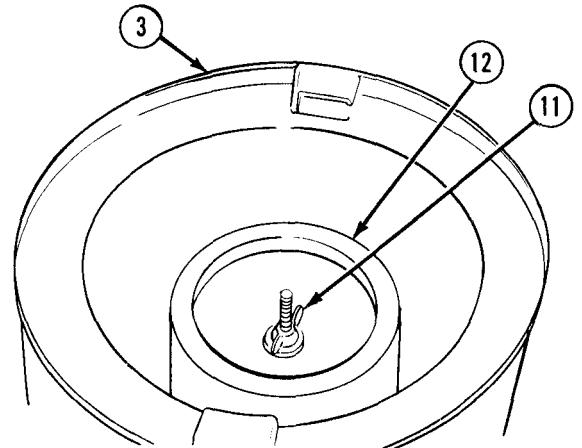


- (6) Remove primary filter element (10) from air cleaner (3).



Fuel System Maintenance Instructions (Cont)

- (7) Remove wingnut (11).
- (8) Remove secondary element (12) from air cleaner (3).



TA182300

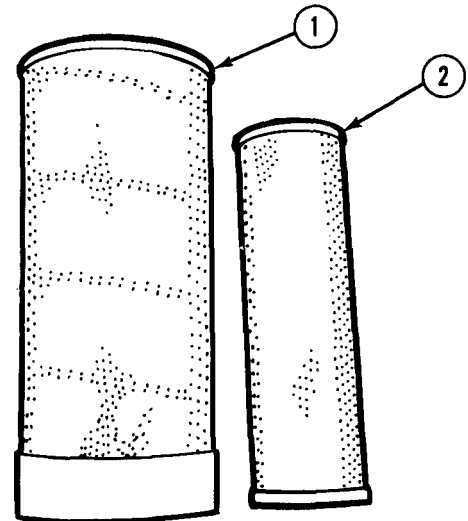
b. Service.

- (1) Check elements (1 and 2) for bends or tears. Replace if damaged.
- (2) Tap side or end of elements (1 and 2) against hand to loosen dirt.

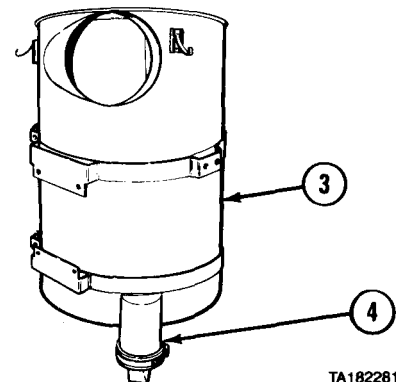
WARNING

Compressed air used for cleaning purposes will not exceed 30 psi (207 kPa). Use only with effective personal protective equipment, goggles, shield, and gloves.

- (3) Insert air nozzle inside elements (1 and 2) and blow out dust with compressed air.
- (4) Blow dust from outside of elements (1 and 2) by holding air nozzle at least six inches from elements.
- (5) Remove soot or oily vapor with warm soapy water.
- (6) Reverse flush with clean water to rinse.
- (7) Allow elements (1 and 2) to air dry.
- (8) Brush dust from side and bottom of air cleaner (3).
- (9) Clean dust from dust unloader (4).



TA185445



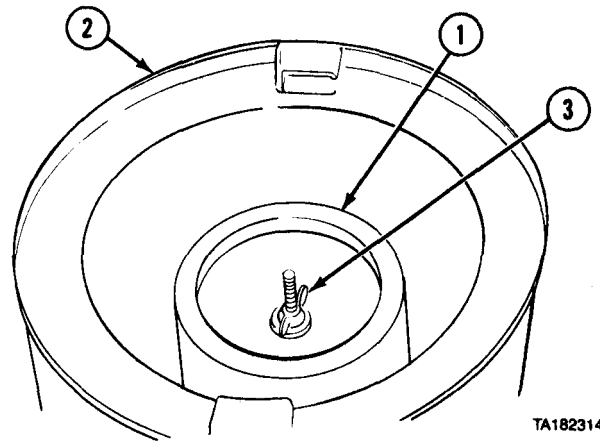
TA182281

Fuel System Maintenance Instructions (Cont)

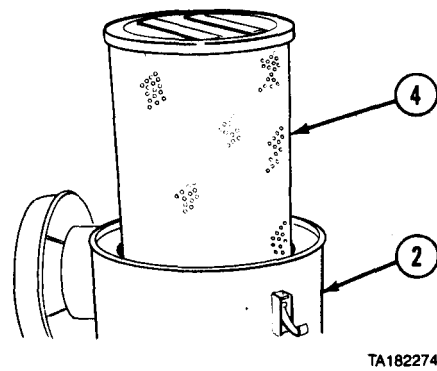
4-3. AIR FILTER ELEMENT REMOVAL/SERVICE/INSTALLATION (CONT).

c. *Installation.*

- (1) Install secondary element (1) in air cleaner (2).
- (2) Install wingnut (3) and tighten.



- (3) Install primary filter element (4) in air cleaner (2).



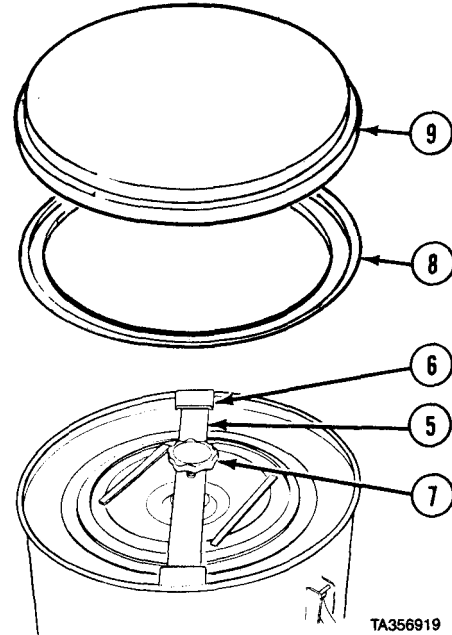
Fuel System Maintenance Instructions (Cont)

- (4) Install retaining bar (5) under clips (6) and tighten knob (7).

WARNING

Adhesives, solvents, and sealing compounds can burn easily, can give off harmful vapors, and are harmful to skin and clothing. To avoid injury or death, keep away from open fire and use in well-ventilated area. If adhesive, solvent, or sealing compound gets on skin or clothing, wash immediately with soap and water.

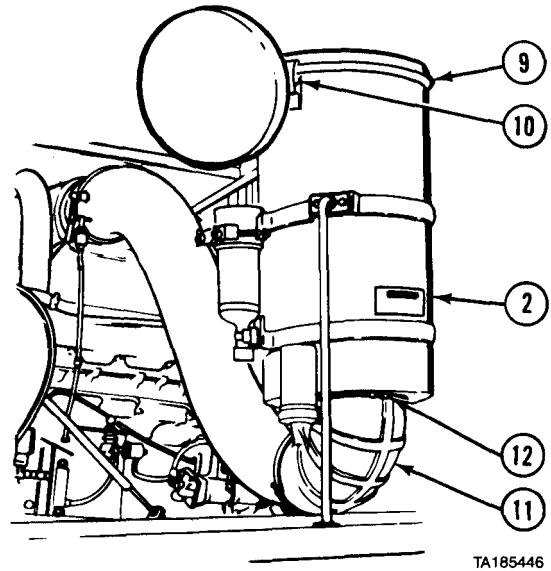
- (5) Install gasket (8) in top cover (9) with adhesive.
 (6) Install top cover (9).



- (7) Hook three latches (10) up around top cover (9).
 (8) Connect elbow (11) to air cleaner (2).
 (9) Install clamp (12).

d. Follow-on Maintenance. None.

END OF TASK



Fuel System Maintenance Instructions (Cont)

4-4. AIR INTAKE DUCTING REMOVAL/INSTALLATION.

This task covers:

- a. Removal
- b. Installation
- c. Follow-on Maintenance

INITIAL SETUP

Models
All

Test Equipment
None

Special Tools
None

Supplies
Compound, sealing, pipe thread, Item 18, Appendix C

Personnel Required
MOS 63S, Heavy wheel vehicle mechanic

References
None

Equipment Condition

| <i>TM or Para</i> | <i>Condition Description</i> |
|-------------------|------------------------------|
| TM 9-2320-279-10 | Engine side panel removed. |
| TM 9-2320-279-10 | Engine cover opened. |

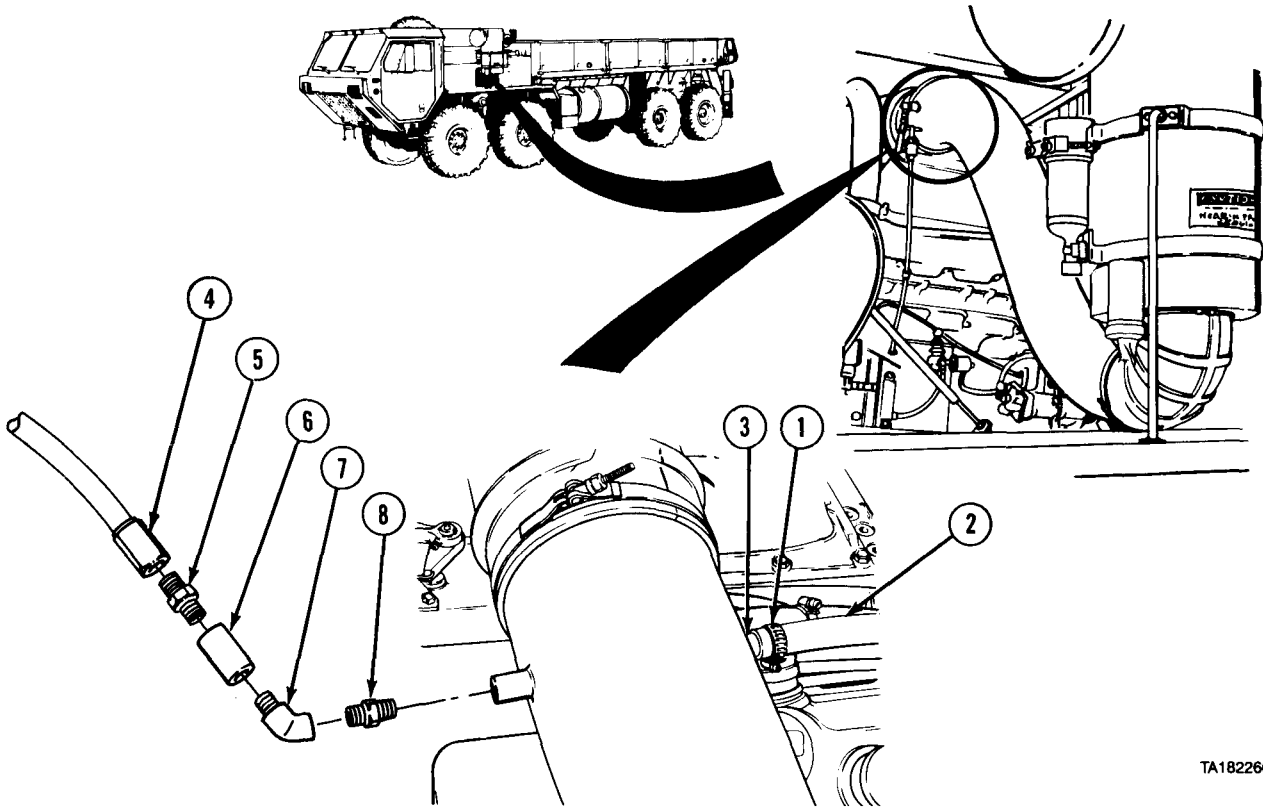
Special Environmental Conditions

None

General Safety Instructions

None

a. Removal.



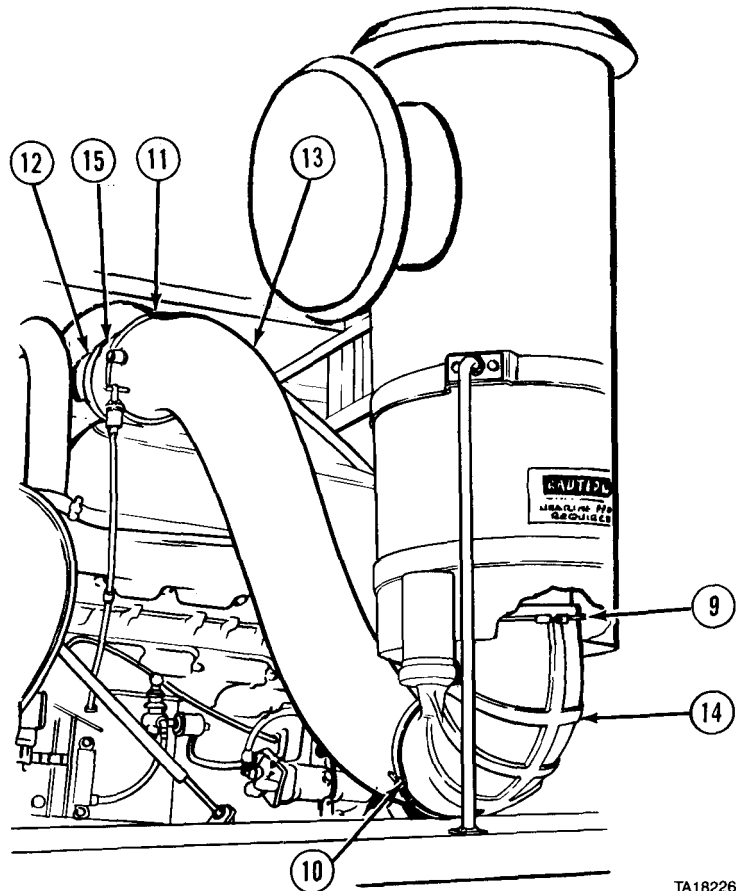
TA182266

Fuel System Maintenance Instructions (Cont)

CAUTION

Do not start engine after air intake elbow is removed from air cleaner or equipment damage could result.

- (1) Remove clamp (1) on air compressor supply hose (2) and remove hose from fitting (3).
- (2) Remove air restriction indicator hose (4) from fitting (5).
- (3) Remove fittings (5 and 6) from elbow (7).
- (4) Remove elbow (7) from fitting (8).
- (5) Remove fitting (8).
- (6) Loosen clamps (9, 10, 11, and 12).
- (7) Remove pipe (13).
- (8) Remove clamps (9 and 10).
- (9) Remove elbow (14).
- (10) Remove reducer (15).
- (11) Remove clamps (11 and 12).



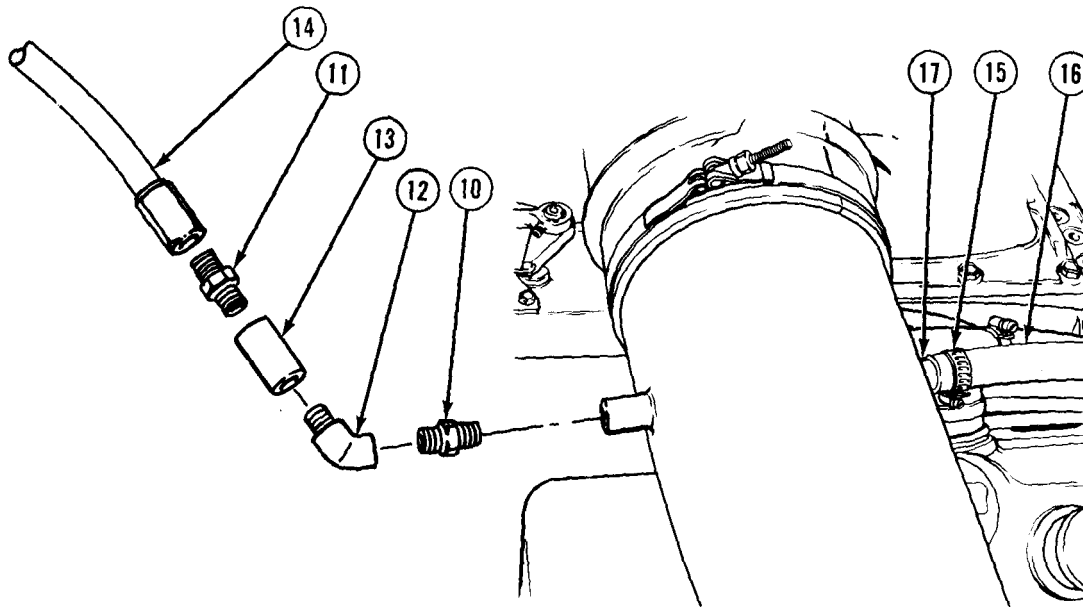
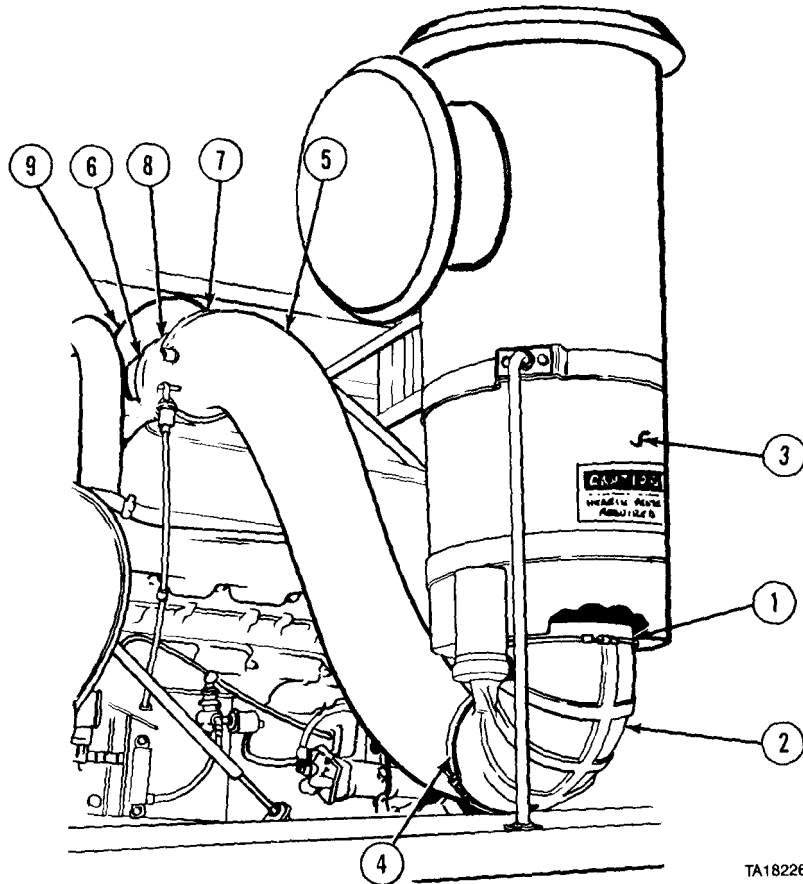
TA182265

Fuel System Maintenance Instructions (Cont)

4-4. AIR INTAKE DUCTING REMOVAL/INSTALLATION (CONT).

b. Installation.

- (1) Install clamp (1) on elbow (2) loosely.
- (2) Connect elbow (2) to air cleaner (3).
- (3) Install clamp (4) on elbow (2) loosely.
- (4) Connect pipe (5) to elbow (2).
- (5) Install clamps (6 and 7) on reducer (8) loosely.
- (6) Attach reducer (8) to turbocharger (9). Tighten clamp (6).
- (7) Attach pipe (5) to reducer (8). Tighten clamp (7).
- (8) Tighten clamps (1 and 4).



Fuel System Maintenance Instructions (Cont)

WARNING

Adhesives, solvents, and sealing compounds can burn easily, can give off harmful vapors, and are harmful to skin and clothing. To avoid injury or death, keep away from open fire and use in well-ventilated area. If adhesive, solvent, or sealing compound gets on skin or clothing, wash immediately with soap and water.

- (9) Coat threads of fittings (10 and 11) and elbow (12) with pipe thread sealing compound.
- (10) Install fitting (10).
- (11) Install elbow (12) and fittings (13 and 11).
- (12) Connect air restriction indicator hose (14) and tighten.
- (13) Install clamp (15) on air compressor supply hose (16) and connect to fitting (17).
- (14) Tighten clamp (15).

c. Follow-on Maintenance.

- (1) Install engine side panel (TM 9-2320-279-10).
- (2) Close engine cover (TM 9-2320-279-10).

END OF TASK

| 4-5. AIR CLEANER ASSEMBLY REMOVAL/INSTALLATION. | |
|--|--|
| This task covers: | |
| a. Removal | c. Follow-on Maintenance |
| b. Installation | |
| INITIAL SETUP | |
| <i>Models</i> | <i>References</i> |
| All | None |
| <i>Test Equipment</i> | <i>Equipment Condition</i> |
| None | <i>TM or Para</i> <i>Condition Description</i> |
| <i>Special Tools</i> | TM 9-2320-279-10 Shut off engine. |
| None | Para 4-3 Air filter element removed. |
| <i>Supplies</i> | Para 4-12 Ether starting aid removed. |
| None | <i>Special Environmental Conditions</i> |
| <i>Personnel Required</i> | None |
| MOS 63S, Heavy wheel vehicle mechanic (2) | <i>General Safety Instructions</i> |
| | None |

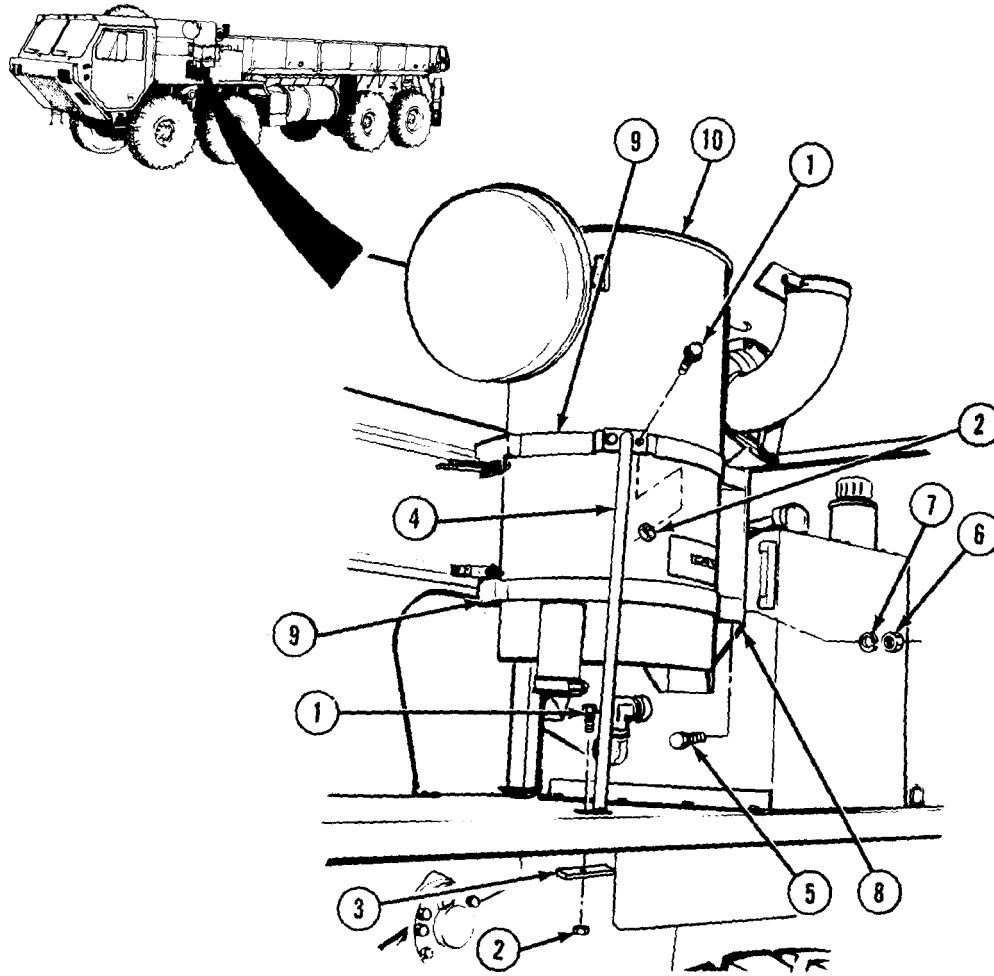
WARNING

If NBC exposure is suspected, all air filter media should be handled by personnel wearing protective equipment. Consult your unit NBC officer or NBC NCO for appropriate handling or disposal instructions.

Fuel System Maintenance Instructions (Cont)

4-5. AIR CLEANER ASSEMBLY REMOVAL/INSTALLATION (CONT).

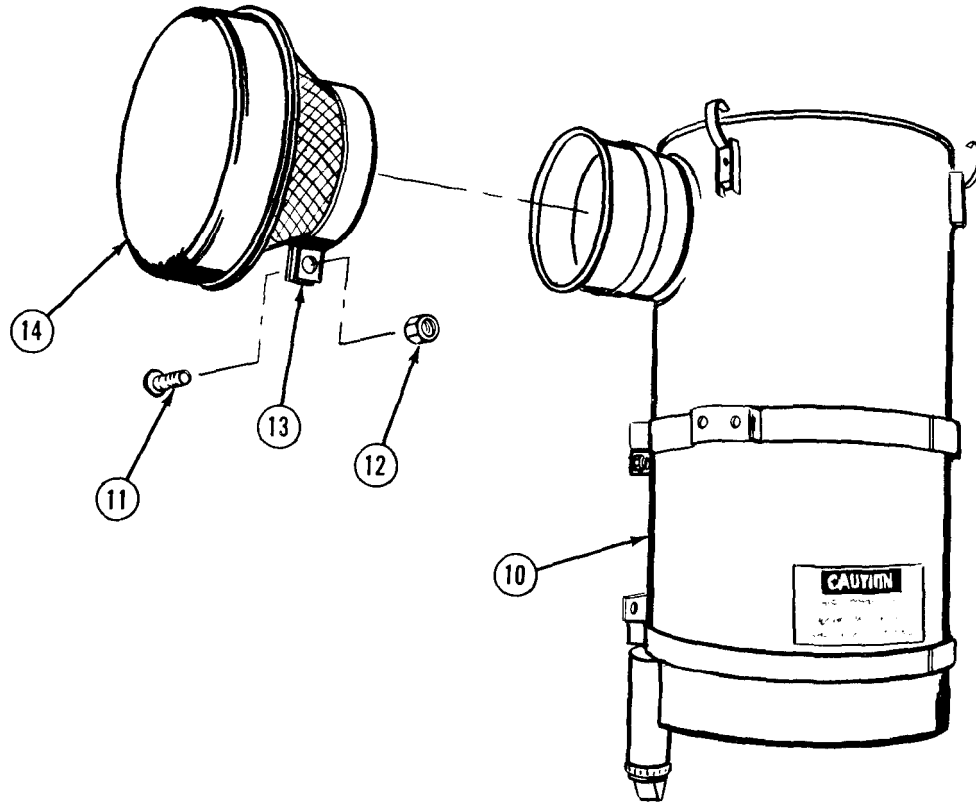
a. Removal.



TA182267

- (1) Remove three screws (1), nuts (2), and plate (3). Remove grab handle (4).
- (2) Soldier A removes four screws (5), nuts (6), and lockwashers (7) from bracket (8) and straps (9) while Soldier B supports air cleaner assembly (10).
- (3) Soldier A and Soldier B remove air cleaner assembly (10) from vehicle.

Fuel System Maintenance Instructions (Cont)



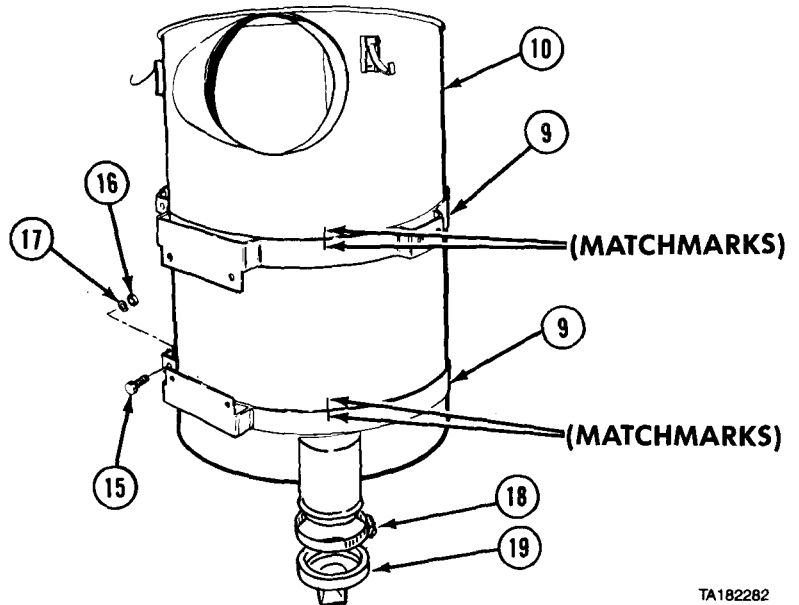
TA182311

(4) Remove screw (11) and nut (12) from clamp (13). Remove weather cap (14) from air cleaner assembly (10).

(5) Matchmark air cleaner assembly (10) and straps (9). Remove two screws (15), nuts (16), and lockwashers (17). Remove straps.

(6) Remove clamp (18).

(7) Remove dust unloader (19).



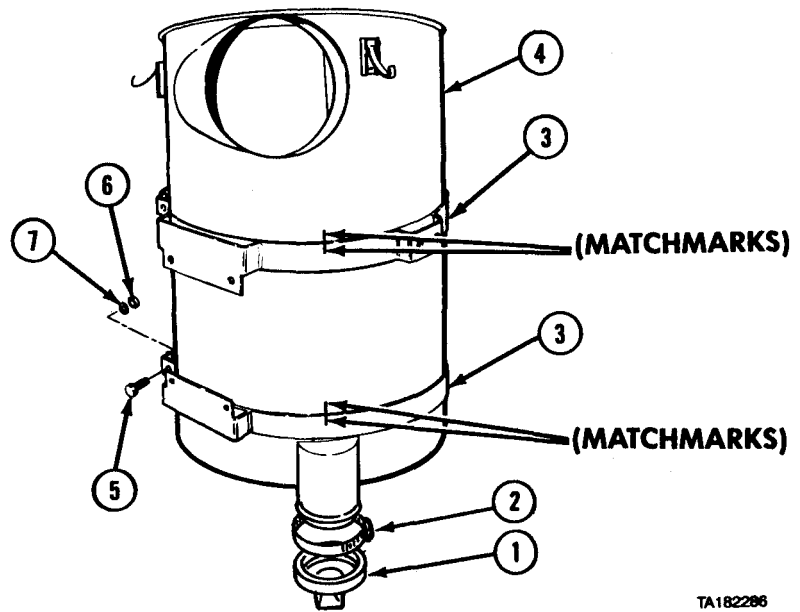
TA182282

Fuel System Maintenance Instructions (Cont)

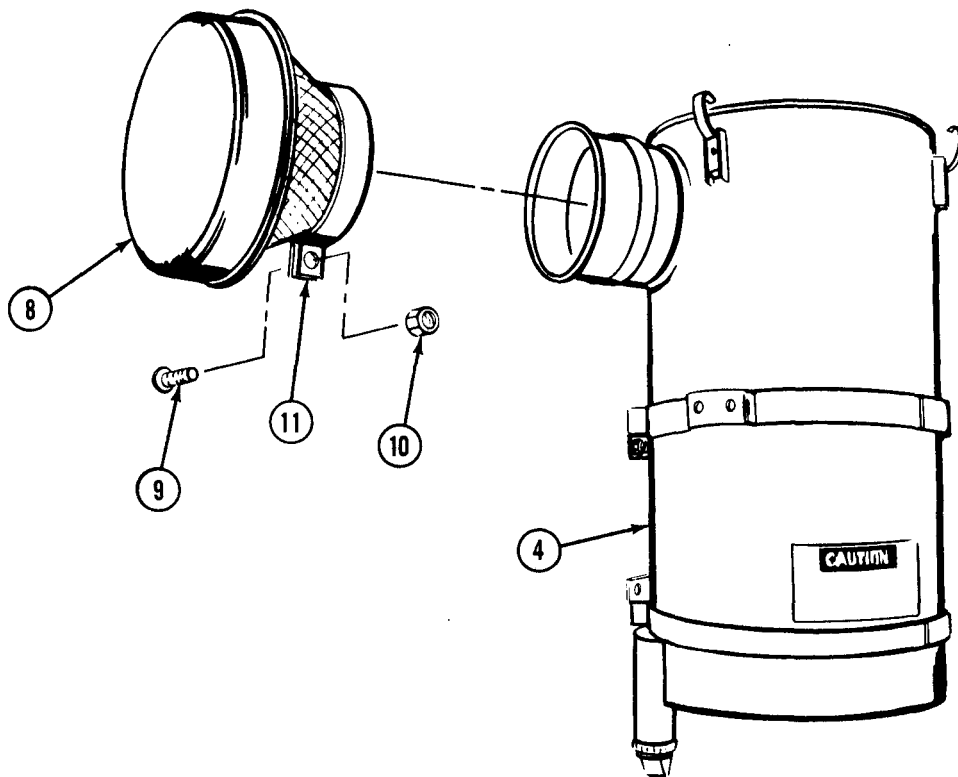
4-5. AIR CLEANER ASSEMBLY REMOVAL/INSTALLATION (CONT).

b. Installation.

- (1) Install dust unloader (1).
- (2) Install clamp (2).
- (3) Align matchmarks and install two straps (3) on air cleaner assembly (4) with two screws (5), nuts (6), and lockwashers (7).



TA182286



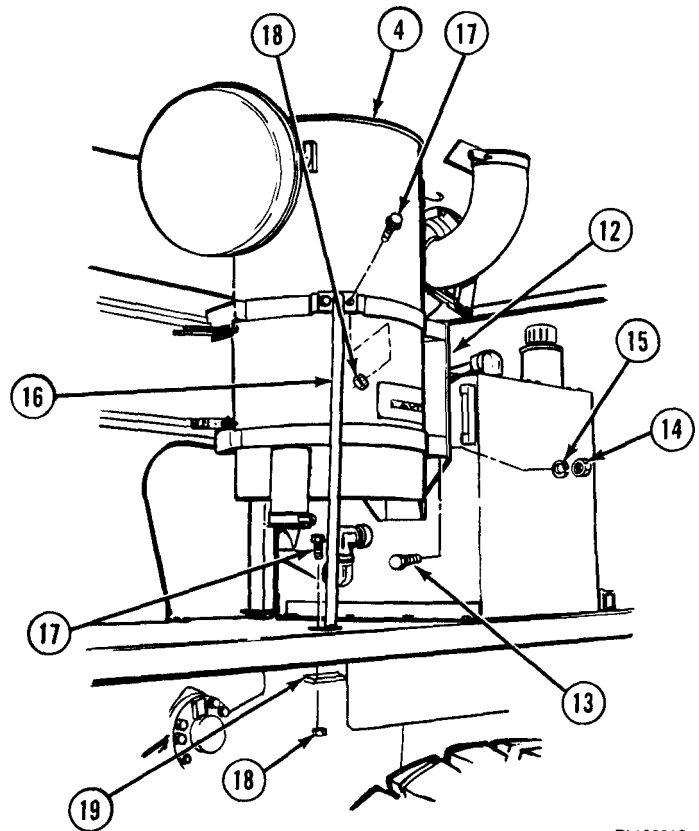
TA182312

- (4) Install weather cap (8) on air cleaner assembly (4) with screw (9) and nut (10) through clamp (11).

Fuel System Maintenance Instructions (Cont)

- (5) Soldier A and Soldier B lift air cleaner assembly (4) and install on bracket (12).
 - (6) Soldier A supports air cleaner assembly (4) while Soldier B installs four screws (13), nuts (14), and lockwashers (15). Soldier A keeps nuts or screws from turning while Soldier B tightens.
 - (7) Install grab handle (16) with three screws (17), locknuts (18), and plate (19).
- c. *Follow-on Maintenance.*
- (1) Install ether starting aid (para 4-12).
 - (2) Install air filter elements (para 4-3).

END OF TASK

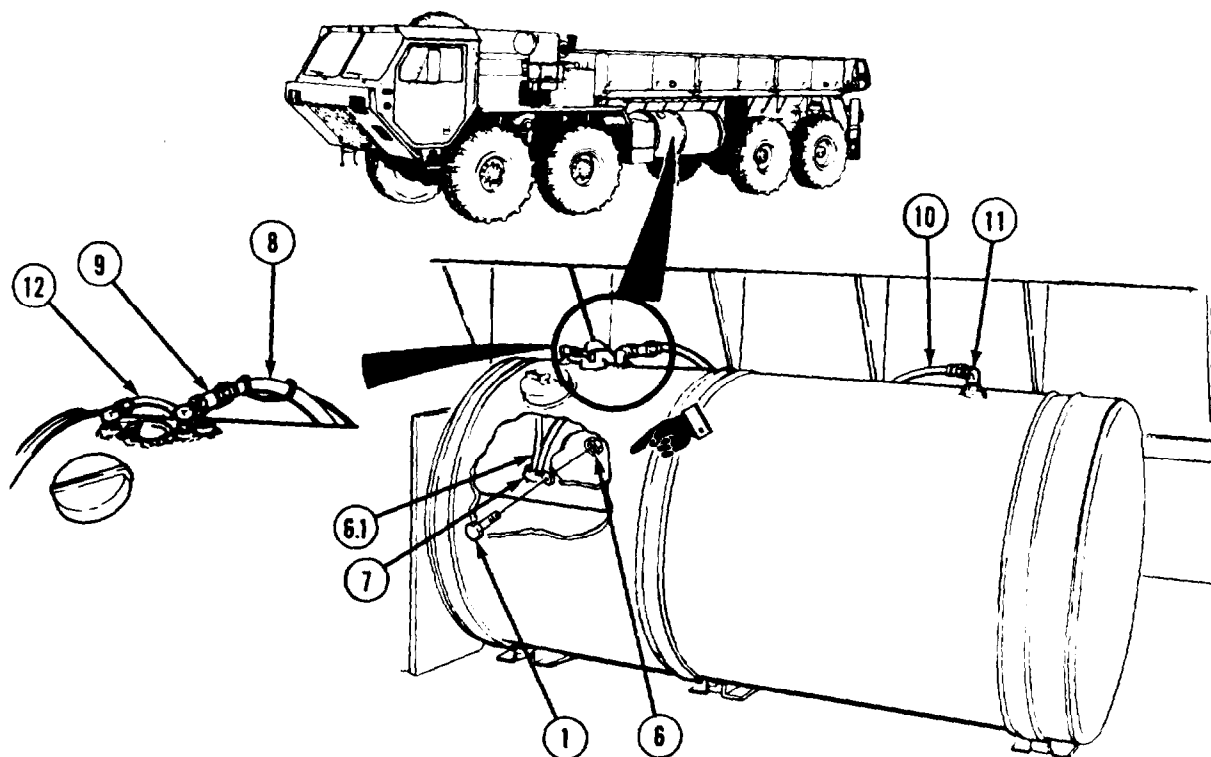


TA182268

Fuel System Maintenance Instructions (Cont)
Section III. FUEL TANK AND LINES

| | | | | | | | | | |
|--|---|------------------------------|------------------------------|------------------|------------------|------------------|---------------------|------------------|----------------------------|
| 4-6. FUEL LINE AND AIR VENT REMOVAL/INSTALLATION. | | | | | | | | | |
| This task covers: | | | | | | | | | |
| a. Removal b. Installation | c. Follow-on Maintenance | | | | | | | | |
| INITIAL SETUP | | | | | | | | | |
| <i>Models</i> All | <i>References</i> None | | | | | | | | |
| <i>Test Equipment</i> None | <i>Equipment Condition</i> <table style="width: 100%; border: none;"> <tr> <td style="width: 30%;"><i>TM or Para</i></td> <td><i>Condition Description</i></td> </tr> <tr> <td>TM 9-2320-279-10</td> <td>Shut off engine.</td> </tr> <tr> <td>TM 9-2320-279-10</td> <td>Spare tire removed.</td> </tr> <tr> <td>TM 9-2320-279-10</td> <td>Engine side panel removed.</td> </tr> </table> | <i>TM or Para</i> | <i>Condition Description</i> | TM 9-2320-279-10 | Shut off engine. | TM 9-2320-279-10 | Spare tire removed. | TM 9-2320-279-10 | Engine side panel removed. |
| <i>TM or Para</i> | | <i>Condition Description</i> | | | | | | | |
| TM 9-2320-279-10 | Shut off engine. | | | | | | | | |
| TM 9-2320-279-10 | Spare tire removed. | | | | | | | | |
| TM 9-2320-279-10 | Engine side panel removed. | | | | | | | | |
| <i>Special Tools</i> None | | | | | | | | | |
| <i>Supplies</i> Ties, cable, plastic, Item 52, Appendix C Compound, sealing, pipe thread, Item 18, Appendix C Compound, corrosion preventive, Item 12.2, Appendix C | <i>Special Environmental Conditions</i> None | | | | | | | | |
| <i>Personnel Required</i> MOS 63S, Heavy wheel vehicle mechanic | <i>General Safety Instructions</i> Use safety goggles. No smoking or flames. Fire extinguisher within reach. | | | | | | | | |

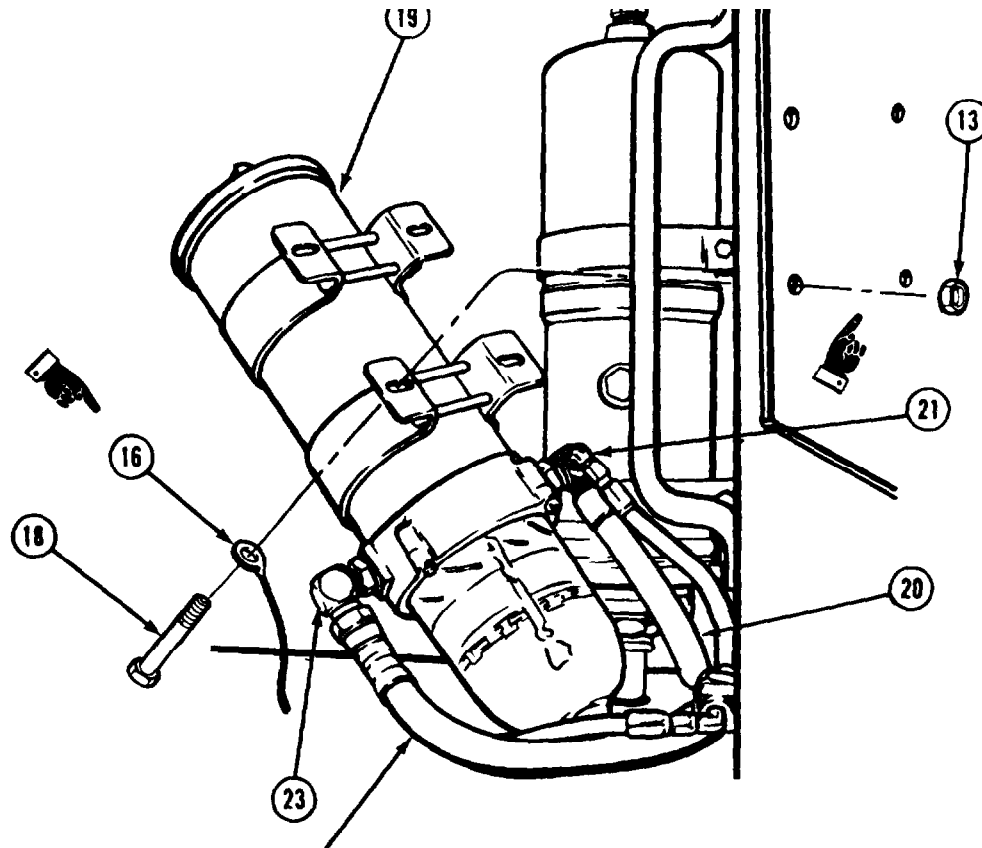
a. Removal.



Fuel System Maintenance Instructions (Cont)

NOTE

- Cut plastic cable ties as required.
 - Some vehicles have a screw, lockwasher, washer, lockwasher, lockwasher and nut. Others have a flanged screw and flanged nut.
- (1) Remove screw (1), locknut (6), and ground wire (6.1) from cushion clip (7). Remove cushion clip.
 - (2) Disconnect fuel supply line (8) from check valve (9). Disconnect fuel return line (10) from elbow (11).
 - (3) Drain fuel from lines (8 and 10) into a suitable container.
 - (4) Remove air vent line (12).



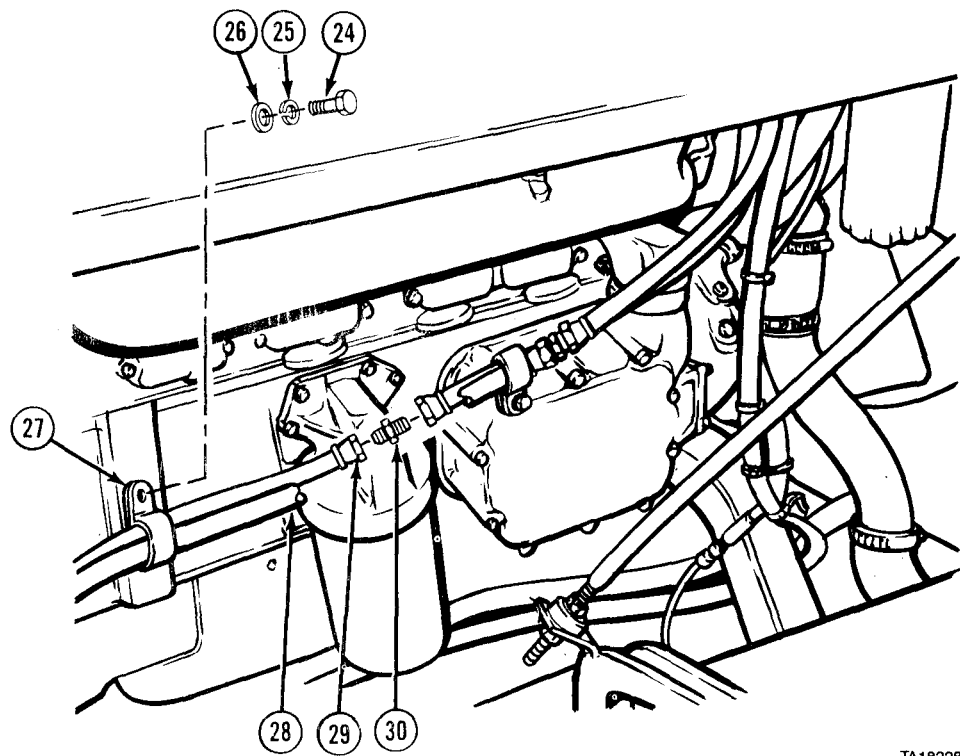
NOTE

Some vehicles have nuts, lockwashers, washers, lockwashers, and screws. Others have flanged nuts and flanged screws.

- (5) Remove four locknuts (13), one ground wire (16), and four screws (18).
- (6) Lower fuel water separator (19) from mounted position.
- (7) Disconnect fuel supply line (20) from fitting (21). Remove fuel supply line from vehicle.
- (8) Disconnect fuel supply line (22) from fitting (23).

Fuel System Maintenance Instructions (Cont)

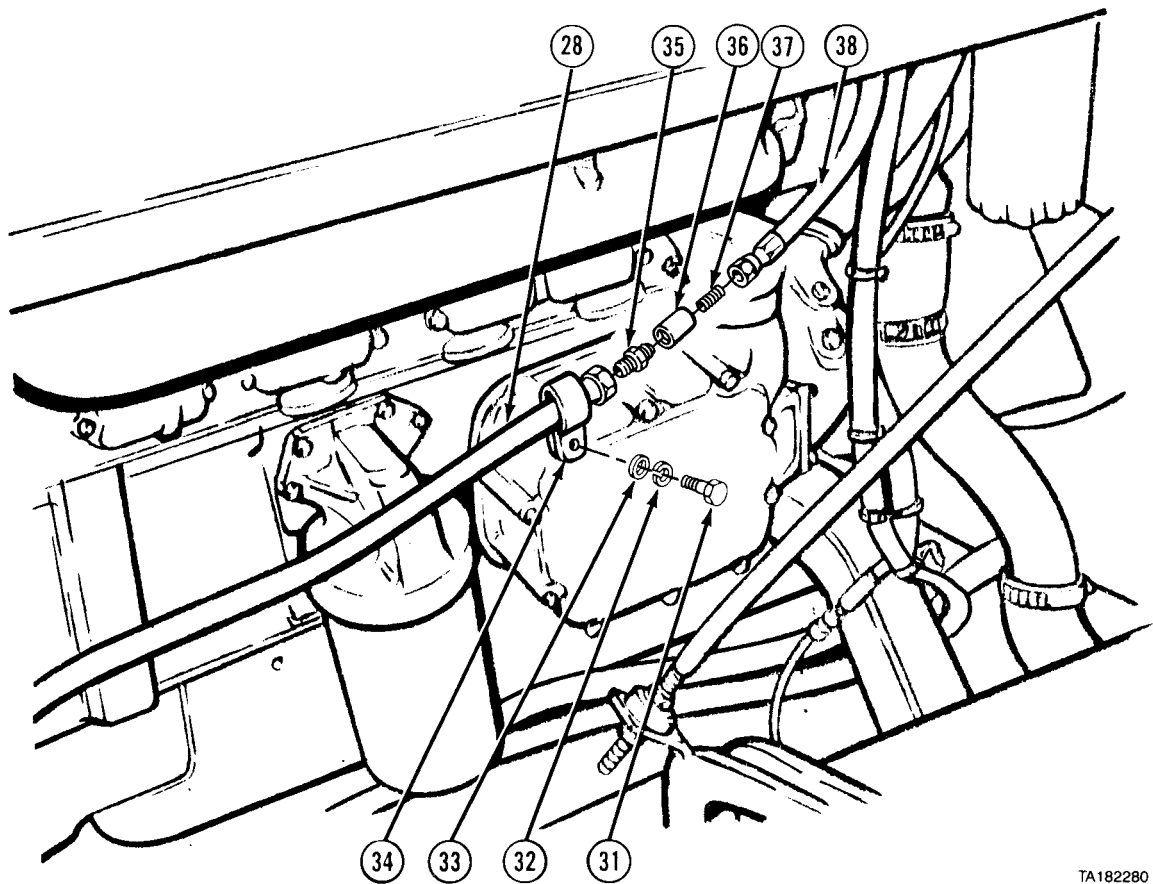
4-6. FUEL LINE AND AIR VENT LINE REMOVAL/INSTALLATION (CONT).



TA182288

- (9) Remove screw (24), lockwasher (25), and washer (26) from clip (27).
- (10) Remove clip (27) from lines (28 and 29).
- (11) Disconnect fuel supply line (29).
- (12) Remove connector (30) from fuel supply line (29).
- (13) Remove fuel supply line (29) from vehicle.

Fuel System Maintenance Instructions (Cont)

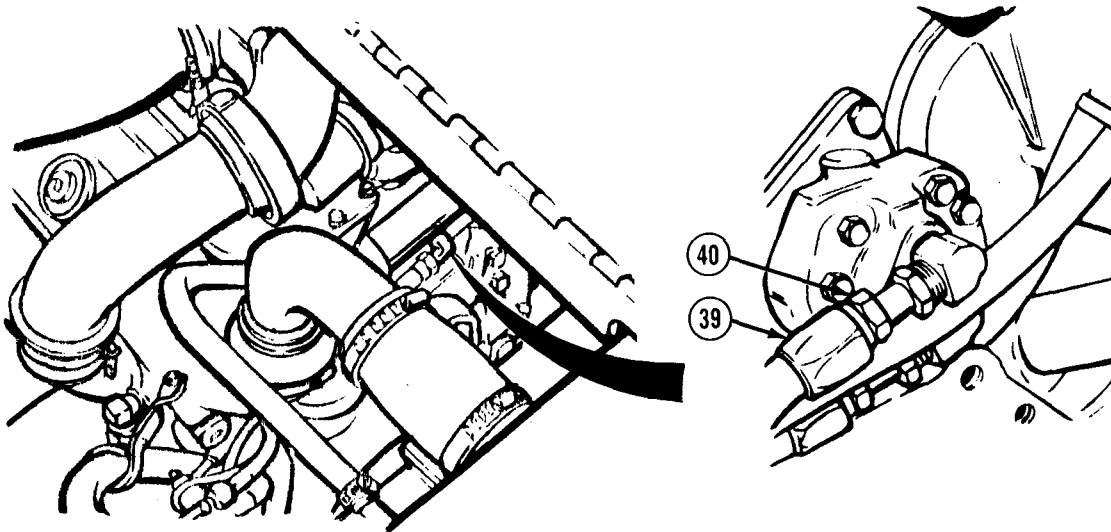


TA182280

- (14) Remove screw (31), lockwasher (32), and washer (33) from clip (34).
- (15) Remove clip (34) from fuel return line (28).
- (16) Remove adapter (35), coupling (36), and nipple (37) from fuel return lines (28 and 38).
- (17) Remove fuel return line (28) from vehicle.

Fuel System Maintenance Instructions (Cont)

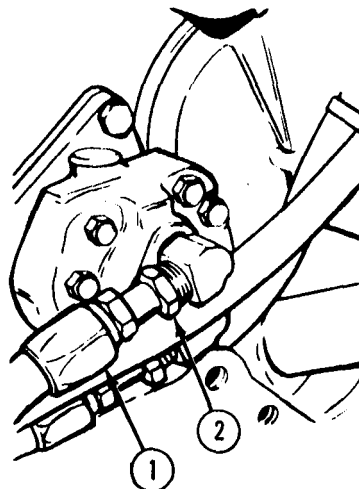
4-6. FUEL LINE AND AIR VENT LINE REMOVAL/INSTALLATION (CONT).



TA182316

- (18) Disconnect fuel supply line (39) from bottom fitting (40).
- (19) Remove fuel supply line (39) from vehicle.

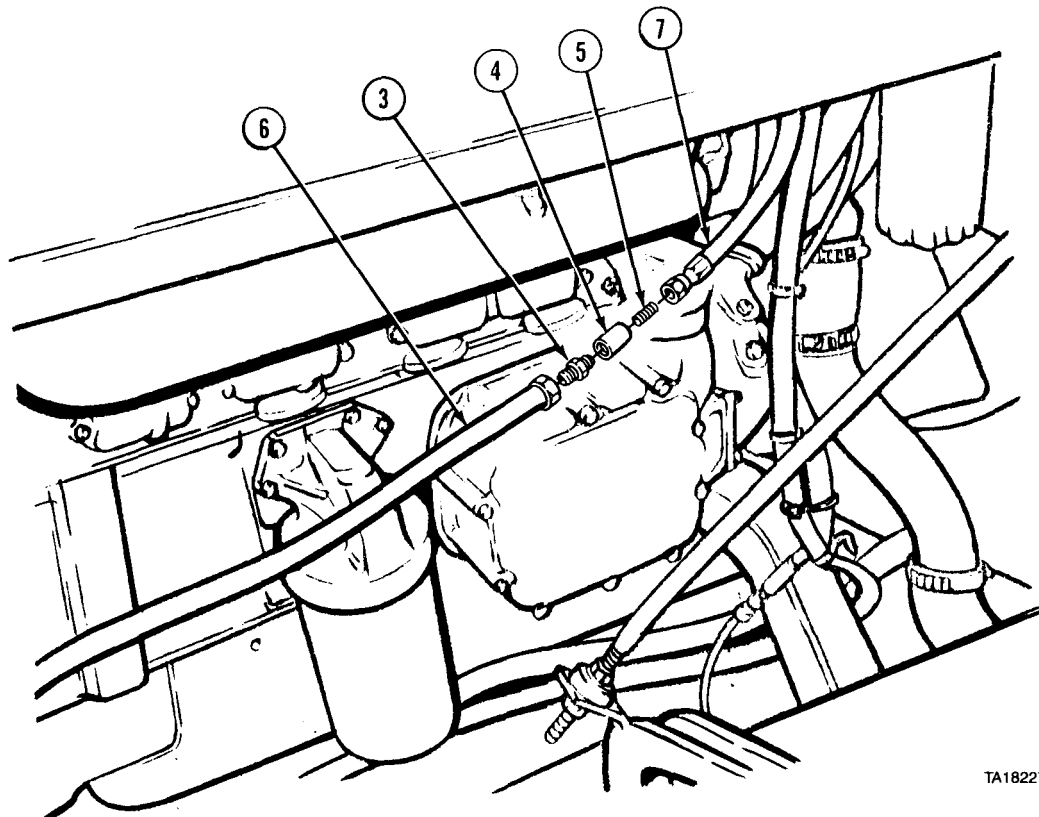
b. Installation.



TA182315

- (1) Connect fuel supply line (1) to bottom fitting (2).

Fuel System Maintenance Instructions (Cont)



TA182279

WARNING

Adhesives, solvents, and sealing compounds can burn easily, can give off harmful vapors, and are harmful to skin and clothing. To avoid injury or death, keep away from open fire and use in well-ventilated area. If adhesive, solvent, or sealing compound gets on skin or clothing, wash immediately with soap and water.

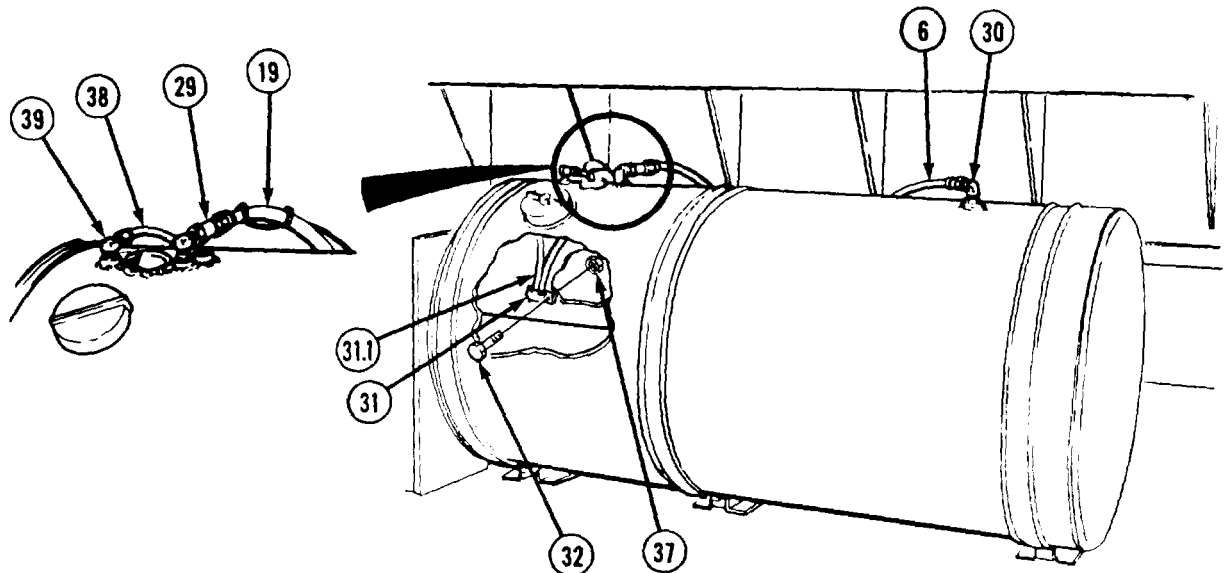
- (2) Apply pipe thread sealing compound to threads of adapter (3), coupling (4), and nipple (5).
- (3) Connect fuel return line (6) to fuel return line (7) with adapter (3), coupling (4), and nipple (5).

Fuel System Maintenance Instructions (Cont)

- (7) Connect fuel supply line (8) to fitting (18).
- (8) Connect fuel supply line (19) to fitting (20).
- (9) Aline fuel-water separator (21) with holes in bracket (22).

NOTE

- To ensure a good ground, clean front and rear of bracket to expose bare metal before attaching ground wire (25).
 - Some vehicles have nuts, lockwashers, washers, lockwashers, and screws. Others have flanged nuts and flanged screws
- (10) Install four screws (23), one ground wire (25), and four locknuts (28).
 - (10.1) Apply corrosion preventive compound to ground wire (25) and locknut (28).



- (10.2) Coat threads of check valve (29) and elbow (30) with pipe thread sealing compound.
- (11) Connect fuel supply line (19) to check valve (29).
- (12) Connect fuel return line (6) to elbow (30).

NOTE

- To ensure a good ground, clean area around cushion clip to expose bare metal before attaching ground wire.
 - Some vehicles have a screw, lockwasher, washer, lockwasher, lockwasher, and nut. Others have a flanged screw and flanged nut.
- (13) Install cushion clip (31) and ground wire (31.1) with screw (32) and locknut (37).
 - (13.1) Apply corrosion preventive compound to ground wire (31.1) and locknut (37).
 - (14) Coat threads of vent (39) with pipe thread sealing compound and install air vent line (38) onto vent (39).

c. Follow-on Maintenance.

- (1) Start engine and bleed fuel system of air (para 2-18b).
- (2) Check fuel lines and fittings for leaks.
- (3) Shut off engine (TM 9-2320-279-10).
- (4) Install engine side panel (TM 9-2320-279-10).
- (5) Stow spare tire (TM 9-2320-279-10).

END OF TASK

Fuel System Maintenance Instructions (Cont)

4-7. FUEL TANK AND BRACKETS REMOVAL/INSTALLATION.

This task covers:

- a. Removal
- b. Cleaning/Inspection
- c. Installation
- d. Follow-on Maintenance

INITIAL SETUP

Models

All

Test Equipment

None

Special Tools

None

Supplies

- Cement, general purpose, synthetic base, Item 7, Appendix C
- Compound, corrosion preventive, Item 12.2, Appendix C
- Compound, sealing, pipe thread, Item 18, Appendix C
- Ties, cable, plastic, Item 52, Appendix C
- Soap chips, Item 45, Appendix C

Personnel Required

MOS 63S, Heavy wheel vehicle mechanic (2)

References

FM 10-20

TB 43-0212

Equipment Condition

TM or Para

TM 9-2320-279-10

Para 7-80

Para 11-30

Condition Description

Shut off engine.

Fuel sending unit removed.

Air reservoir No. 2 removed (if strap and bracket are to be removed.)

Special Environmental Conditions

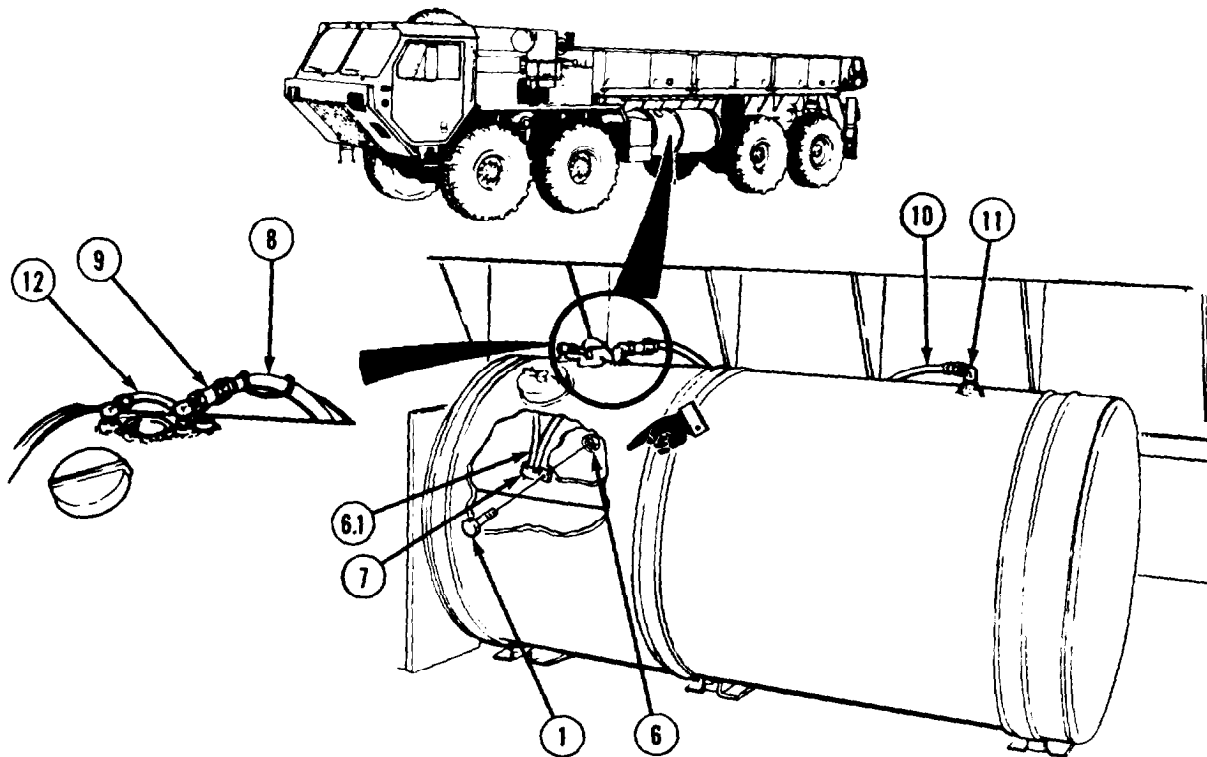
None

General Safety Instructions

No smoking or flames.

Fire extinguisher within reach.

a. Removal



Fuel System Maintenance Instructions (Cont)

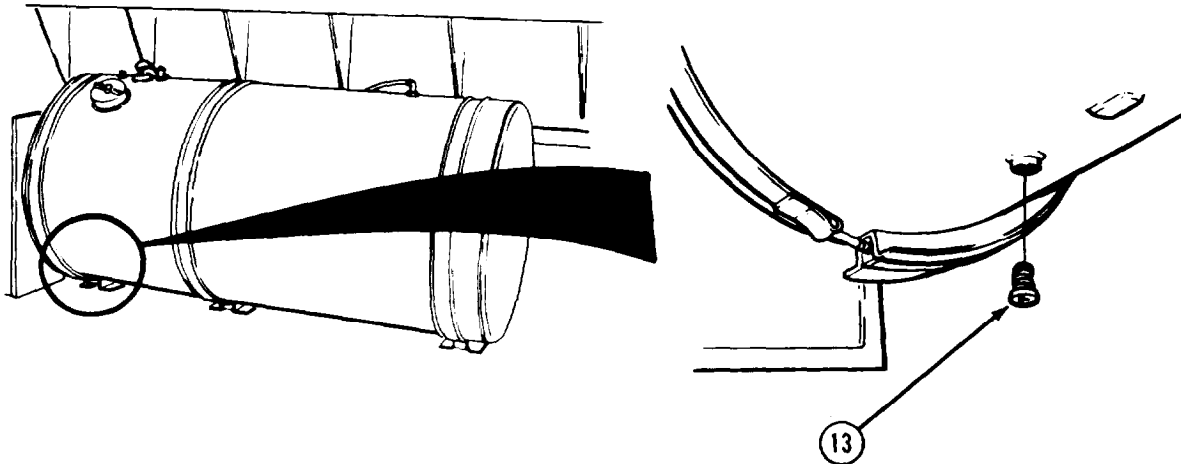
NOTE

- Cut plastic cable ties as required.
 - Some vehicles have a screw, lockwasher, washer, lockwasher, lockwasher and nut. Others have a flanged screw and flanged nut.
- (1) Remove screw (1), locknut (6), and ground wire (6.1) from cushion clip (7). Remove cushion clip.
 - (2) Disconnect fuel supply line (8) from check valve (9). Disconnect fuel return line (10) from elbow (11).
 - (3) Drain fuel from lines (8 and 10) into suitable container.

NOTE

There are two types of air vent lines. Model A is 12 in. (304.8 mm) long while Model B is 24 in. (609.6 mm) long. Both are removed the same way.

- (4) Remove air vent line (12).



WARNING

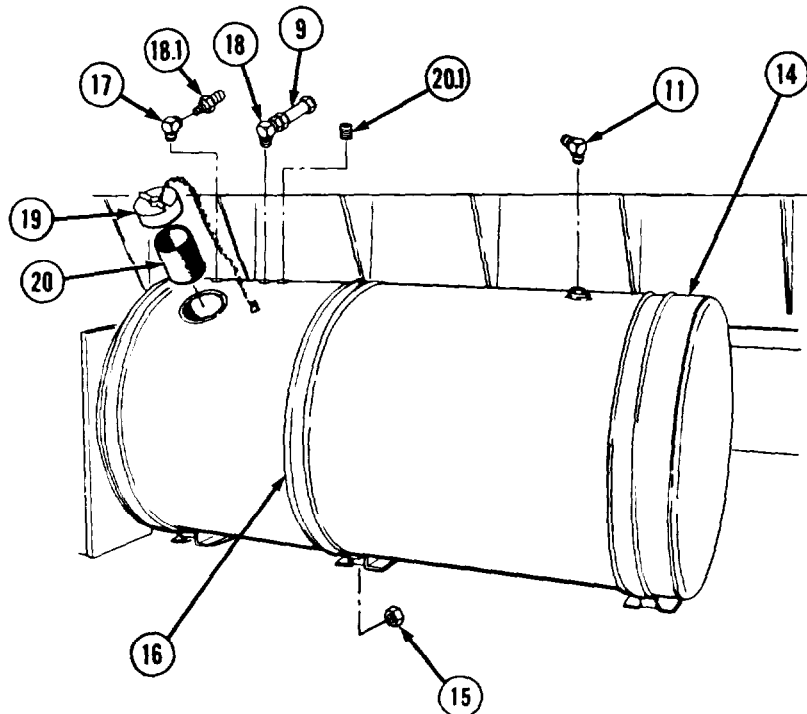
Fuel is very flammable and can explode easily. To avoid serious injury or death, keep fuel away from open fire and keep fire extinguisher within easy reach. When working with fuel, post signs that read NO SMOKING WITHIN 50 FEET OF VEHICLE.

- (5) Remove drainplug (13), and drain fuel into suitable container.

Fuel System Maintenance Instructions (Cont)

4-7. FUEL TANK AND BRACKETS REMOVAL/INSTALLATION (CONT).

- (6) Support fuel tank (14).
- (7) Remove three nuts (15) from three fuel tank straps (16).
- (8) Pull fuel tank straps (16) outward and remove fuel tank (14).



NOTE

There are two types of air vents. Model A has a removable hose fitting and a 12 in. (304.8 mm) long air vent line. Model B uses a 24 in. (609.6 mm) long air vent line and does not have a removable hose fitting. Both models are removed the same way.

- (9) Remove air vent (17) and two elbows (11 and 18).

NOTE

Do step (9.1) for Model A only.

- (9.1) Remove fitting (18.1) from air vent (17).
- (10) Remove tank cap (19) and fuel strainer (20).
- (11) Remove check valve (9) from elbow (18).

NOTE

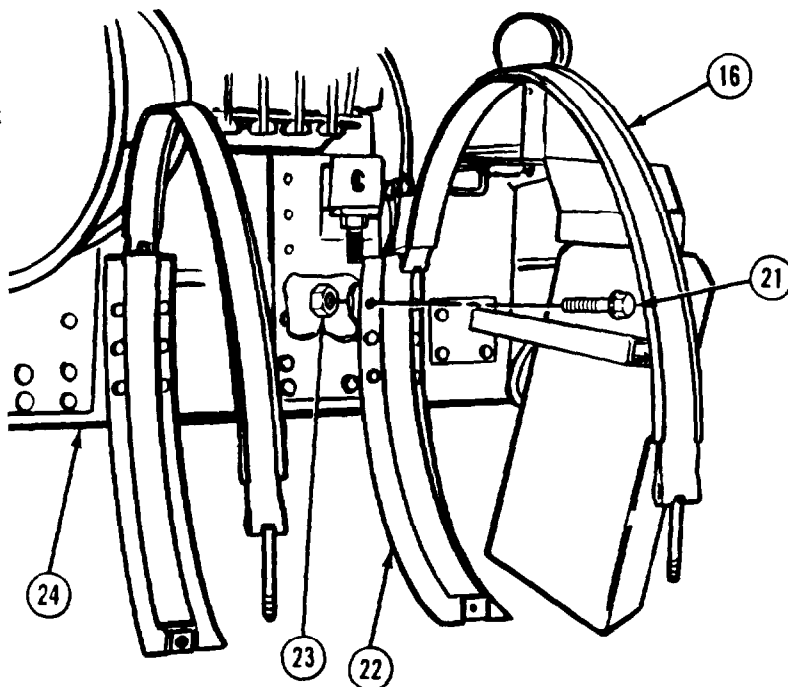
Some models of fuel tanks contain a socket head pipe plug. Perform step (11.1) for these models.

- (11.1) Remove socket head pipe plug (20.1).
- (12) Soldier A removes six screws (21) from each fuel tank bracket (22) while Soldier B removes nuts (23).

NOTE

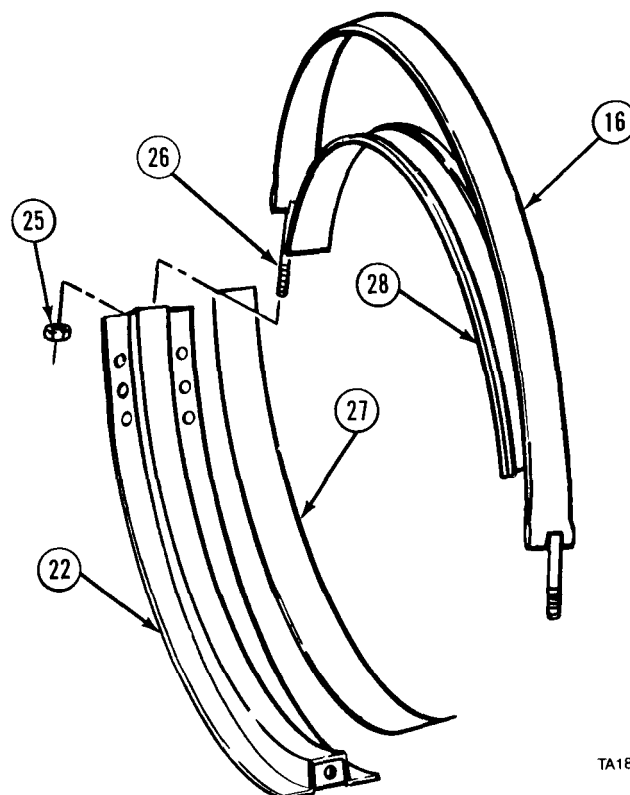
On M983 and M984 vehicles, mud flap chain must be removed from fuel tank strap.

- (13) Remove three fuel tank brackets (22) with fuel tank straps (16) from frame (24).



Fuel System Maintenance instructions (Cont)

- (14) Remove three nuts (25) from three tee bolts (26) and remove three fuel tank straps (16) from three fuel tank brackets (22).
- (15) Remove three bracket liners (27) from three fuel tank brackets (22) and three strap liners (28) from three fuel tank straps (16).



TA182322

b. *Cleaning/Inspection.***WARNING**

Adhesives, solvents, and sealing compounds can burn easily, can give off harmful vapors, and are harmful to skin and clothing. To avoid injury or death, keep away from open fire and use in well-ventilated area. If adhesive, solvent, or sealing compound gets on skin or clothing, wash immediately with soap and water.

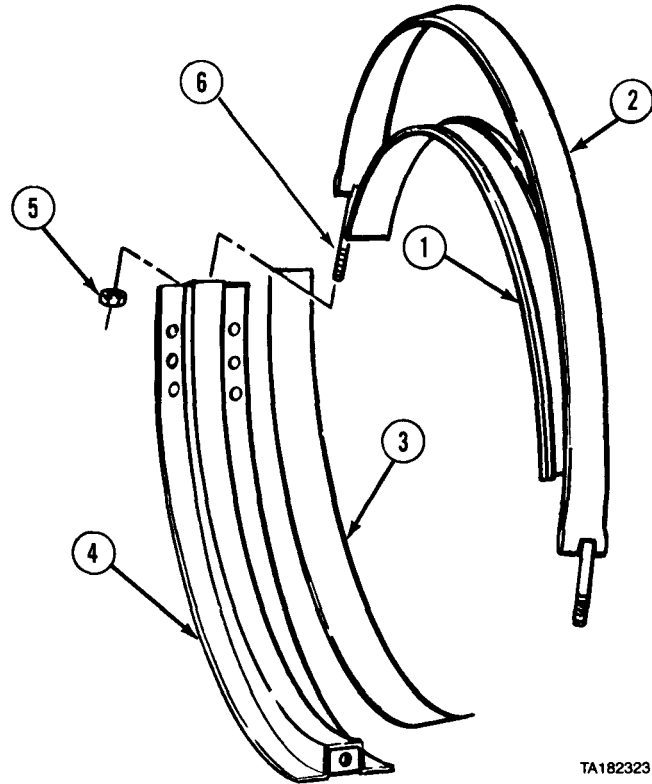
- (1) Clean fuel tank straps and fuel tank brackets with dry cleaning solvent, wire brush, and cloth. Clean liners with soapy water. Rinse liners clean with clear water.
- (2) Inspect fuel tank brackets and fuel tank straps for cracks, breaks, and badly rusted areas. Inspect bracket liners for brittleness, cracks, and breaks.
- (3) Purge and clean fuel tank (TB 43-0212), as required.
- (4) Inspect fuel tank for cracks, broken welds, and stripped threads.

Fuel System Maintenance Instructions (Cont)

4-7. FUEL TANK AND BRACKETS REMOVAL/INSTALLATION (CONT).

c. Installation.

- (1) Position three strap liners (1) on three fuel tank straps (2).
- (2) Coat three bracket liners (3) with general purpose cement and install on three fuel tank brackets (4).
- (3) Install three fuel tank straps (2) on fuel tank brackets (4) with nuts (5) on tee bolts (6).

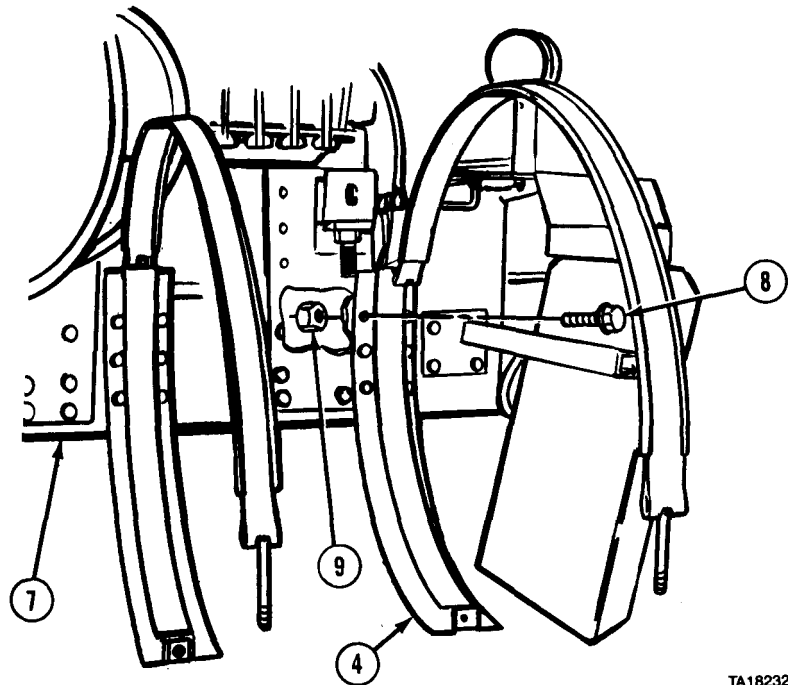


TA182323

NOTE

On M983 and M984 vehicles, mud flap chain and hardware must be attached to fuel tank strap.

- (4) Soldier A installs three fuel tank brackets (4) on frame (7) with six screws (8) for each fuel tank bracket while Soldier B installs nuts (9) for screws behind frame.



TA182324

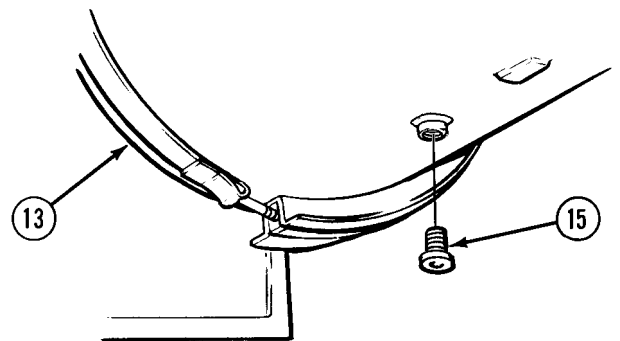
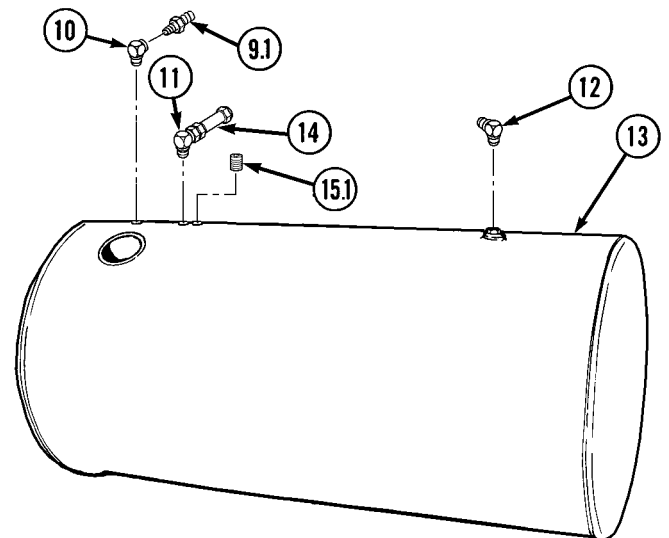
Fuel System Maintenance Instructions (Cont)

WARNING

Adhesives, solvents, and sealing compounds can burn easily, can give off harmful vapors, and are harmful to skin and clothing. To avoid injury or death, keep away from open fire and use in well-ventilated area. If adhesive, solvent, or sealing compound gets on skin or clothing, wash immediately with soap and water.

NOTE

- There are two types of air vents. Model A has a removable hose fitting and a 12 in. (304.8 mm) long air vent line. Model B uses a 24 in. (609.9 mm) long air vent line and does not have a removable hose fitting. Both models are installed the same way.
 - Do step (4.1) for Model A only.
- (4.1) Install fitting (9.1) into air vent (10).
 (5) Coat air vent (10) and two elbows (11, and 12) with pipe thread sealing compound and install elbows in fuel tank (13).
 (6) Coat check valve (14) with pipe thread sealing compound and install on elbow (11).
 (7) Coat drainplug (15) with pipe thread sealing compound and install plug in fuel tank (13).

**WARNING**

Some models of fuel tanks have a socket head pipe plug. Some models of fuel tanks have a fusible socket head pipe plug. Fusible socket head pipe plug must be used with non-vented tank cap or damage to equipment and injury or death to personnel may occur. Refer to TM 9-2320-279-24P for proper identification of parts.

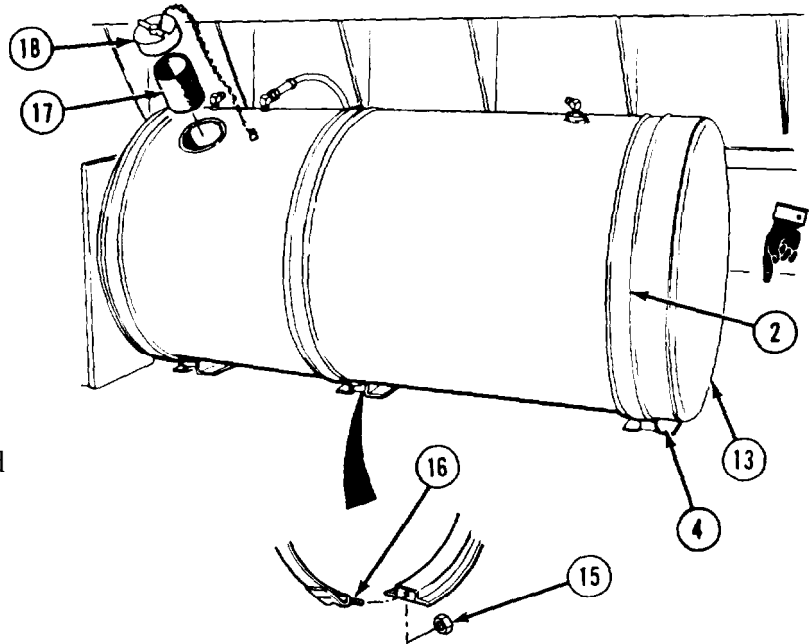
NOTE

Some models of fuel tanks contain a socket head pipe plug. Perform step (7.1) for these models.

- (7.1) Coat socket head pipe plug (15.1) with pipe thread sealing compound and install plug in fuel tank (13).

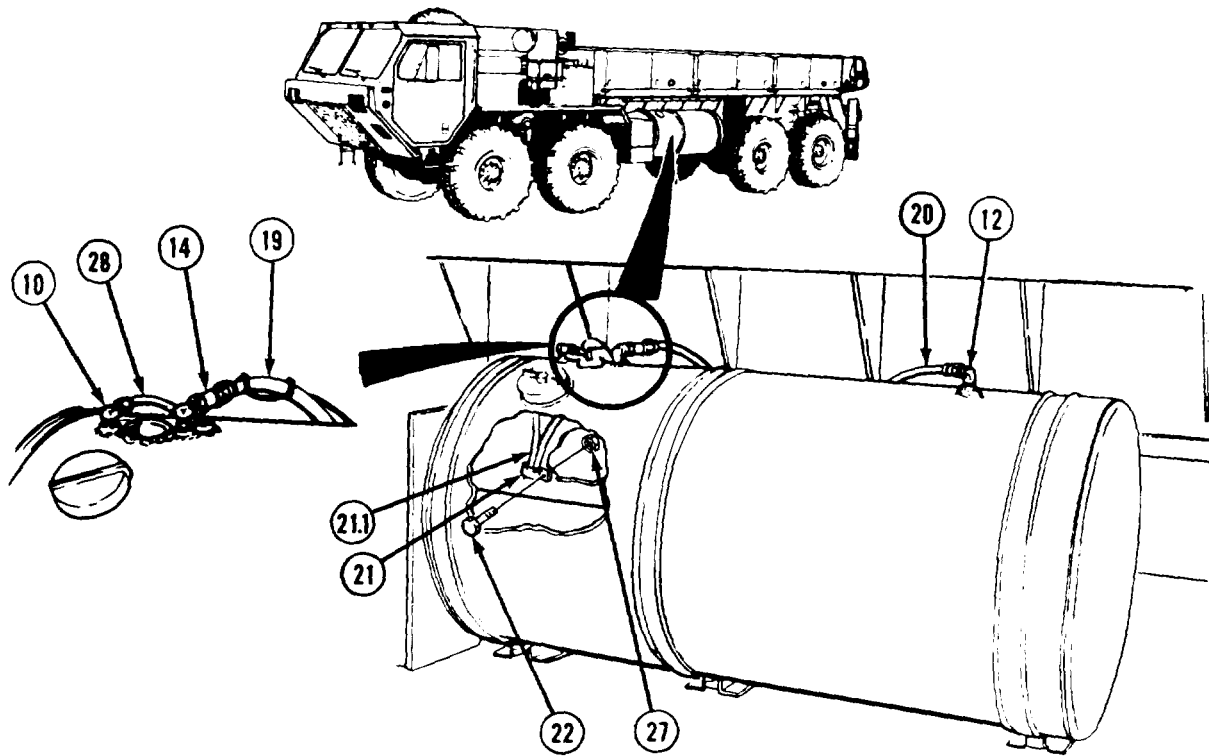
Fuel System Maintenance Instructions (Cont)

- (7.2) Coat liners on straps (2) and brackets (4) with a soap solution.
- (8) Raise fuel tank (13) with suitable lifting device and position fuel tank on fuel tank brackets (4). Install three nuts (15) loosely on three tee bolts (16).
- (9) Adjust fuel tank (13) with fuel tank brackets (4) so fuel lines will reach elbows.
- (10) Tighten nuts (15) to 50 lb-ft. (67.8 N•m).
- (10.1) Tap strap (2) with a mallet and check torque on nuts (15).
- (10.2) Repeat step (10.1) until nuts (15) remain at 50 lb-ft. (67.8 N•m).
- (11) Install fuel strainer (17) and tank cap (18).



Fuel System Maintenance Instructions (Cont)

4-7. FUEL TANK AND BRACKETS REMOVAL/INSTALLATION (CONT).



- (11.1) Coat threads of check valve (14) and elbow (12) with pipe thread sealing compound.
- (12) Connect fuel supply line (19) to check valve (14).
- (13) Connect fuel return line (20) to elbow (12).

NOTE

- To ensure a good ground, clean area around cushion clip to expose bare metal before attaching ground wire.
- Some vehicles have a screw, lockwasher, washer, lockwasher, lockwasher and nut. Others have a flanged screw and flanged nut.

- (14) Install cushion clip (21) and ground wire (21.1) with screw (22) and locknut (27).
- (14.1) Apply corrosion preventive compound to ground wire (21.1) and locknut (27).

NOTE

Use plastic cable ties as required to support hoses and wires behind fuel tank and under chassis.

- (15) Install air vent line (28) to vent valve (10).

d. Follow-on Maintenance.

- (1) Install air reservoir No. 2 (if strap and bracket were removed) (para 11-30).
- (2) Install fuel sending unit (para 7-80).
- (3) Fill fuel tank (TM 9-2320-279-10).
- (4) Check fuel tank and connections for leaks.

END OF TASK

Fuel System Maintenance Instructions (Cont)

Section IV. ENGINE STOP SOLENOID

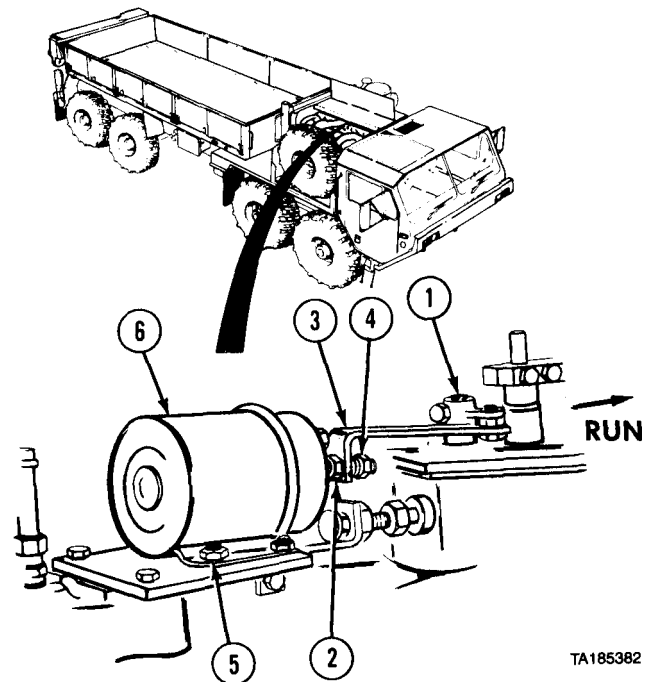
| | |
|---|--|
| 4-8. ENGINE STOP SOLENOID ADJUSTMENT. | |
| This task covers: | |
| <ul style="list-style-type: none"> a. Adjustment b. Follow-on Maintenance | |
| INITIAL SETUP | |
| <i>Models</i> | <i>References</i> |
| All | None |
| <i>Test Equipment</i> | <i>Equipment Condition</i> |
| None | <i>TM or Para</i> <i>Condition Description</i> |
| <i>Special Tools</i> | TM 9-2320-279-10 Shut off engine. |
| None | Para 7-91 Batteries disconnected. |
| <i>Supplies</i> | TM 9-2320-279-10 Engine side panel removed. |
| None | Para 16-9 Engine cover removed. |
| <i>Personnel Required</i> | <i>Special Environmental Conditions</i> |
| MOS 63S, Heavy wheel vehicle mechanic | None |
| | <i>General Safety Instructions</i> |
| | None |

a. Adjustment.

- (1) Hold stop lever (1) in run position.
- (2) Adjust nut (2) to touch lever (3).
- (3) Tighten nut (2 and 4) against lever (3).
- (4) Move lever (1) to stop position; if lever binds, loosen mounting bolts (5) and align solenoid (6).

b. Follow-on Maintenance.

- (1) Connect batteries (para 7-91).
- (2) Start engine and check operation of engine stop switch (TM 9-2320-279-10).
- (3) Shut off engine (TM 9-2320-279-10).
- (4) Install engine cover (para 16-9).
- (5) Install engine side panel (TM 9-2320-279-10).



TA185382

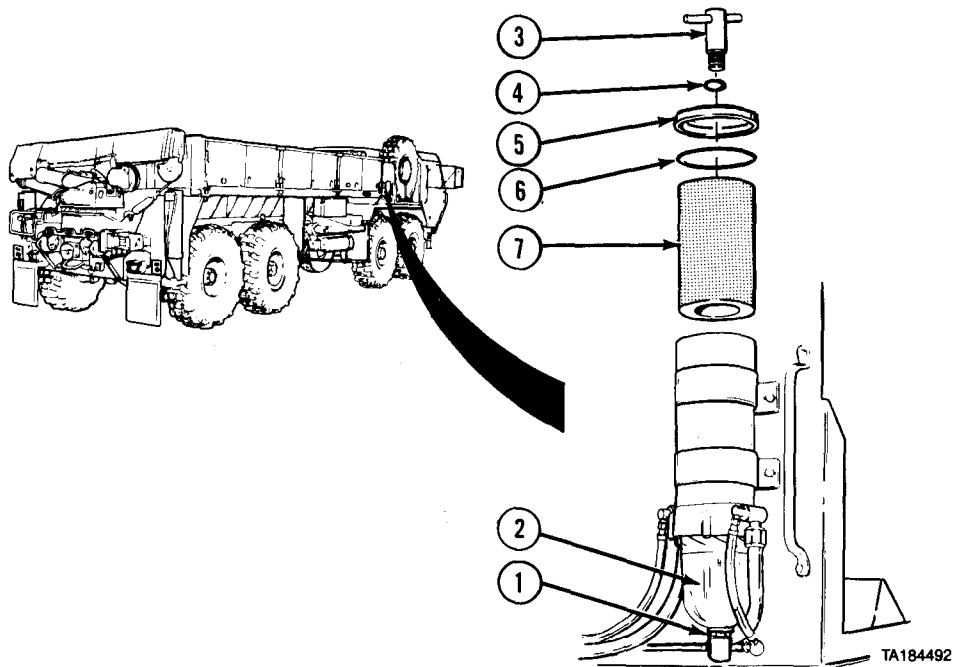
END OF TASK

Fuel System Maintenance Instructions (Cont)

Section V. FUEL FILTERS

| | |
|--|--|
| 4-9. FUEL-WATER SEPARATOR SERVICE. | |
| This task covers: | |
| <ul style="list-style-type: none"> a. Service b. Follow-on Maintenance | |
| INITIAL SETUP | |
| <i>Models</i> | <i>References</i> |
| All | None |
| <i>Test Equipment</i> | <i>Equipment Condition</i> |
| None | <i>TM or Para</i> <i>Condition Description</i> |
| <i>Special Tools</i> | TM 9-2320-279-10 Shut off engine. |
| None | <i>Special Environmental Conditions</i> |
| <i>Supplies</i> | None |
| Oil, fuel, diesel, Item 27, Appendix C | <i>General Safety Instructions</i> |
| <i>Personnel Required</i> | No smoking or flames. |
| MOS 63S, Heavy wheel vehicle mechanic | Fire extinguisher within reach. |

a. Service.



Fuel System Maintenance Instructions (Cont)

- (1) Open drain valve (1) and drain fuel-water separator (2).
 - (2) Remove T-handle (3), preformed packing (4), lid (5), and preformed packing (6).
 - (3) Remove filter element (7).
 - (4) Install filter element (7).
 - (5) Close drain valve (1).
 - (6) Pour clean diesel fuel into body of fuel-water separator (2) until full.
 - (7) Wet lid (5) and preformed packing (6) with fuel.
 - (8) Install preformed packing (6), lid (5), preformed packing (4), and T-handle (3).
- b. *Follow-on Maintenance.*
- (1) Start engine (TM 9-2320-279-10).
 - (2) Check engine operation (TM 9-2320-279-10).
 - (3) Shut off engine (TM 9-2320-279-10).

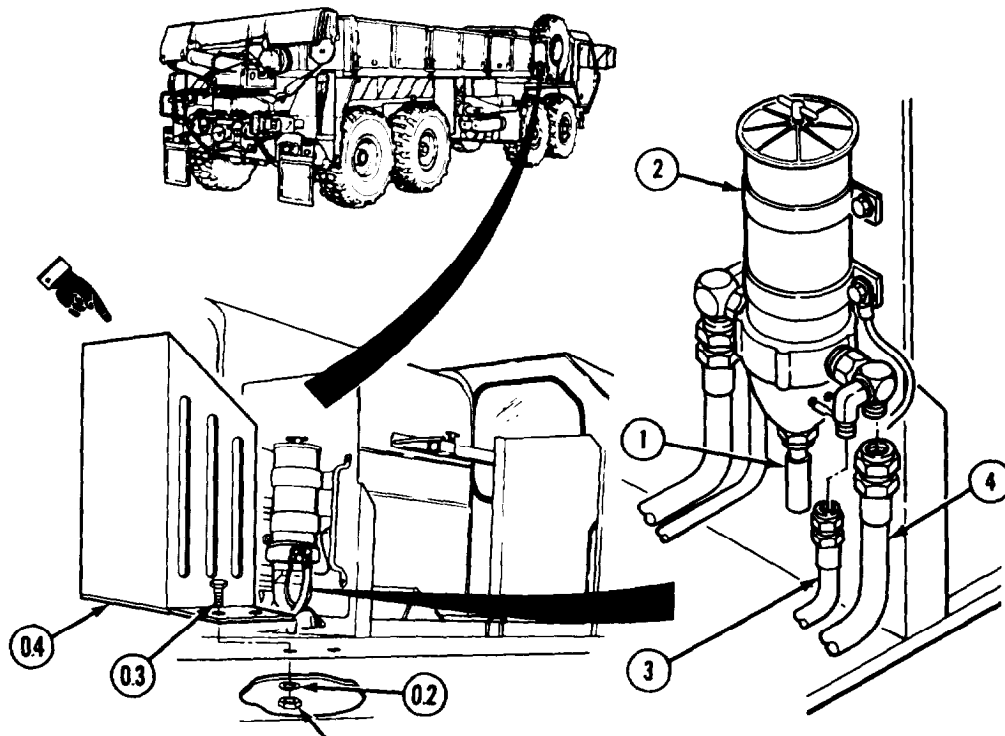
END OF TASK

| | |
|---|--|
| 4-10. FUEL-WATER SEPARATOR REMOVAL/REPAIR/INSTALLATION. | |
| This task covers: | |
| a. Removal | d. Assembly |
| b. Disassembly | e. Installation |
| c. Cleaning/Inspection | f. Follow-on Maintenance |
| INITIAL SETUP | |
| <i>Models</i> | <i>References</i> |
| All | None |
| <i>Test Equipment</i> | <i>Equipment Condition</i> |
| None | <i>TM or Para</i> <i>Condition Description</i> |
| <i>Special Tools</i> | TM 9-2320-279-10 Shut off engine. |
| None | <i>Special Environmental Conditions</i> |
| <i>Supplies</i> | None |
| Solvent, dry cleaning, Item 47, Appendix C | <i>General Safety Instructions</i> |
| Compound, sealing, pipe thread, Item 18, Appendix C | No smoking or flames. |
| Tags, identification, Item 48, Appendix C | Fire extinguisher within reach. |
| Oil, fuel, diesel, Item 27, Appendix C | |
| <i>Personnel Required</i> | |
| MOS 63S, Heavy wheel vehicle mechanic | |

Fuel System Maintenance Instructions (Cont)

4-10. FUEL-WATER SEPARATOR REMOVAL/REPAIR/INSTALLATION (CONT).

a. Removal.



NOTE

Model B has a guard that protects the fuel-water separator. Do step (0.1) for Model B.

(0.1) Remove three nuts (0.1), lockwashers (0.2), screws (0.3), and guard (0.4).

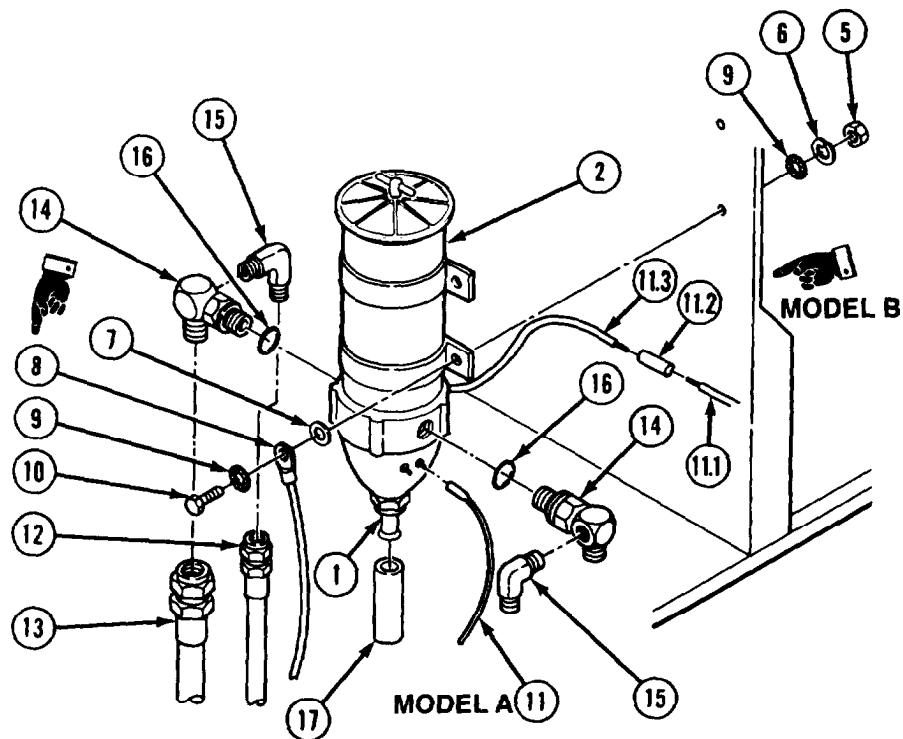
NOTE

Tag and mark fuel lines and wires before removal.

(1) Open drain valve (1) and drain fuel-water separator (2).

(2) Disconnect fuel lines (3 and 4).

Fuel System Maintenance Instructions (Cont)



NOTE

Some vehicles have nuts, lockwashers, and screws. Others have flanged nuts and screws.

- (3) Remove four nuts (5), three lockwashers (6), four washers (7), one ground wire (8), two lockwashers (9), and four screws (10).

NOTE

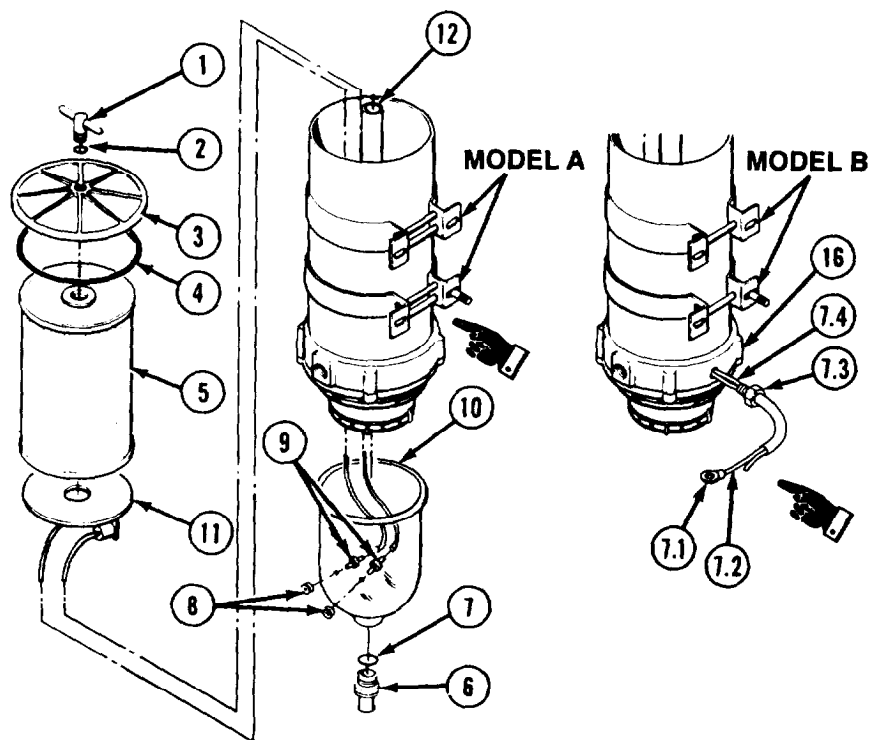
There are two models of fuel-water separators. Model A has two wires connected at the bowl. Model B has two wires at the back of the cylinder ring. Do step (4) for Model A. Do steps (4.1) and (4.2) for Model B.

- (4) Disconnect ground wire (8) and electrical wire (11) from fuel water separator (2).
- (4.1) Cut harness wire (11.1) at connector (11.2).
- (4.2) Cut connector (11.2) from fuel-water separator wire (11.3).
- (5) Disconnect fuel line (12 and 13).
- (6) Remove two elbows (14) and two elbows (15).
- (7) Remove two preformed packings (16) from elbows (14).
- (8) Remove hose (17) from drain valve (1).

Fuel System Maintenance Instructions (Cont)

4-10. FUEL-WATER SEPARATOR REMOVAL/REPAIR/INSTALIATION (CONT).

b. Disassembly.



NOTE

There are two models of fuel-water separators. Model A uses two screws in each bracket. Model B has one screw in each bracket.

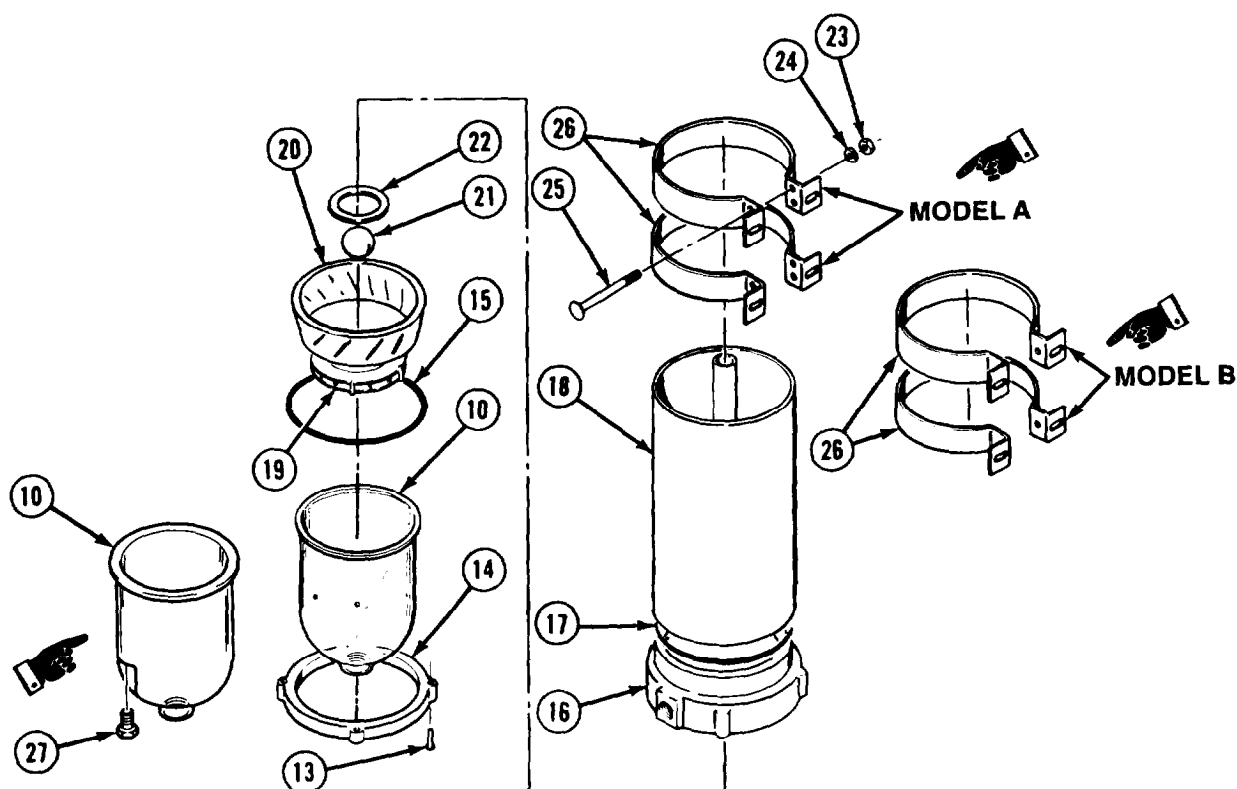
- (1) Remove T-handle (1), preformed packing (2), lid (3), and preformed packing (4).
- (2) Remove filter element (5).
- (3) Remove drain valve (6) and gasket (7).

NOTE

There are two models of fuel-water separators. Model A uses a bowl with feedthrough terminal connectors. Model B uses a feedthrough pigtail. Do step (4) for Model A and steps (4.1) and (4.2) for Model B.

- (4) Remove two retainers (8) from heater terminals (9) and push heater terminals inside bowl (10).
- (4.1) Cut ring terminal (7.1) from ground wire (7.2).
- (4.2) Loosen heater pigtail retainer (7.3) and push pigtail (7.4) inside cylinder ring (16).
- (5) Remove heater assembly (11).
- (6) Remove return tube (12).

Fuel System Maintenance Instructions (Cont)



- (7) Remove four screws (13), bowl ring (14), and bowl (10).

NOTE

Some models have a different bowl configuration that contains a plug. Do step (7.1) for these models.

- (7.1) Remove plug (27) from bowl (10).
 (8) Remove gasket (15).
 (9) Remove cylinder ring (16) and gasket (17) from cylinder (18).
 (10) Remove centrifuge (19), baffle (20), ball (21), and gasket (22) from cylinder (18).

NOTE

There are two models of fuel-water separators. Model A has two screws in each bracket. Model B has one screw in each bracket. Do step (11) for Model A and step (11.1) for Model B.

- (11) Remove four nuts (23), washers (24), screws (25), and two brackets (26) from cylinder (18).
 (11.1) Remove two nuts (23), washers (24), screws (25), and two brackets (26) from cylinder (18).

c. Cleaning/Inspection.**WARNING**

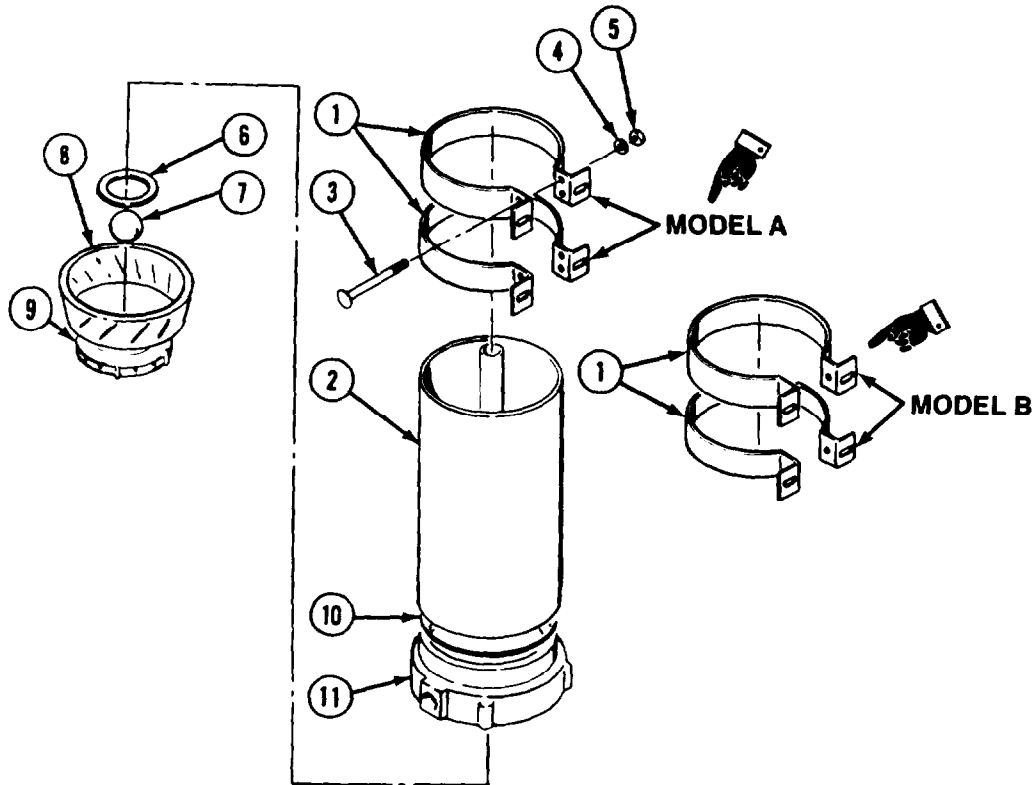
Adhesives solvents, and sealing compounds can burn easily, can give off harmful vapors, and are harmful to skin and clothing. To avoid injury or death, keep away from open fire and use in well-ventilated area. If adhesive, solvent, or sealing compound gets on skin or clothing, wash immediately with soap and water.

- (1) Clean all metal parts in drycleaning solvent.
 (2) Check threaded parts for crossed or stripped threads. Replace all damaged parts.
 (3) Check all plastic parts for damage. Replace all damaged parts.
 (4) Check cylinder for damage. Replace cylinder if damaged.

Fuel System Maintenance Instructions (Cont)

4.10. FUEL-WATER SEPARATOR REMOVAL/REPAIR/INSTALLATION (CONT).

d. Assembly.



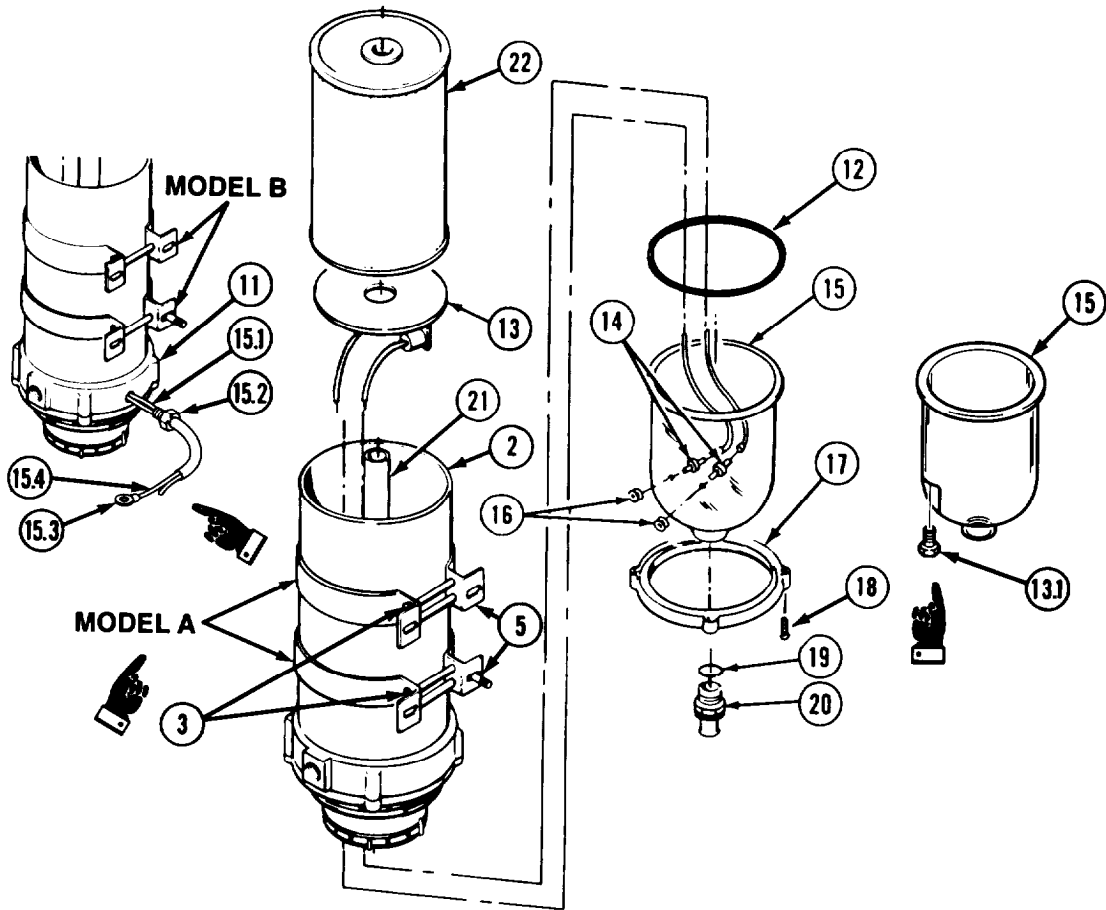
NOTE

There are two models of fuel-water separators. Model A has two screws in each bracket. Model B has one screw in each bracket. Do step (1) for Model A and Step (1.1) for Model B.

- (1) Install two brackets (1) on cylinder (2) with four screws (3), washers (4), and nuts (5). Do not tighten at this time.
- (1.1) Install two brackets (1) on cylinder (2) with two screws (3), washers (4), and nuts (5). Do not tighten at this time.
- (2) Install gasket (6), ball (7), battle (8), and centrifuge (9) in lower end of cylinder (2).
- (3) Install gasket (10) and cylinder ring (11) to cylinder (2).

Fuel System Maintenance Instructions (Cont)

4.10. FUEL-WATER SEPARATOR REMOVAL/REPAIR/INSTALLATION (CONT).



Fuel System Maintenance Instructions (Cont)

- (4) Install gasket (12) in base of cylinder (2).
- (5) Install heater assembly (13) in cylinder (2).

NOTE

Some models have a different bowl configuration that contains a plug. Do step (5.1) for these models.

- (5.1) Install plug (13.1) in bowl (15).

NOTE

There are two models of fuel-water separators. Model A uses a bowl with feedthrough terminal connectors. Model B uses a feedthrough pigtail. Do step (6) for Model A and step (6.1) for Model B.

- (6) Install heater terminals (14) through holes in bowl (15) and install retainers (16) to hold.
- (6.1) Install heater pigtail (15.1) through hole in cylinder ring (11) and heater pigtail retainer (15.2). Tighten retainer (15.2). Install ring terminal (15.3) on ground wire (15.4).
- (7) Slide bowl ring (17) over bowl (15) and install four screws (18).
- (8) Install gasket (19) on drain valve (20). Install drain valve in bowl (15).

WARNING

Adhesives, solvents, and sealing compounds can burn easily, can give off harmful vapors, and are harmful to skin and clothing. To avoid injury or death, keep away from open fire and use in well-ventilated area. If adhesive, solvent, or sealing compound gets on skin or clothing, wash immediately with soap and water.

- (9) Coat threads of return tube (21) with pipe thread sealing compound and install in cylinder (2).
- (10) Install filter element (22) in cylinder (2).

NOTE

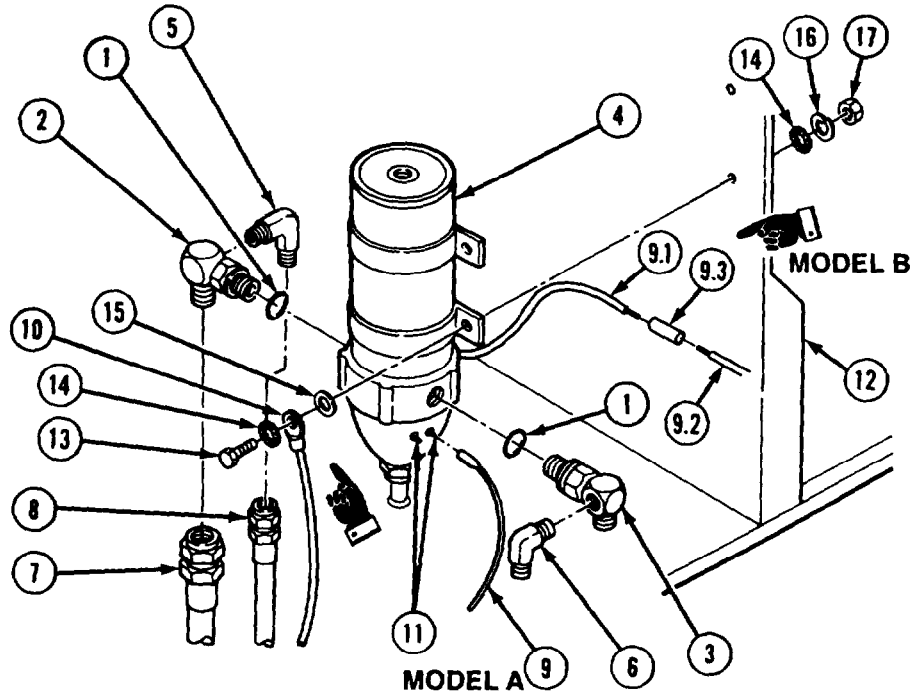
There are two models of fuel-water separators. Model A uses two screws in each bracket. Model B has one screw in each bracket. Do step (10.1) for Model A and step (10.2) for Model B.

- (10.1) Tighten four nuts (5) on bracket screws (3).
- (10.2) Tighten two nuts (5) on bracket screws (3).
- (11) Make sure drain valve (20) is closed.

Fuel System Maintenance Instructions (Cont)

4.10. FUEL-WATER SEPARATOR REMOVAL/REPAIR/INSTALLATION (CONT).

e. Installation



- (1) Install two preformed packings (1) on elbows (2 and 3).
- (2) Install two elbows (2 and 3) on fuel-water separator (4).

WARNING

Adhesives, solvents, and sealing compounds can burn easily, can give off harmful vapors, and are harmful to skin and clothing. To avoid injury or death, keep away from open fire and use in well-ventilated area. If adhesive, solvent, or sealing compound gets on skin or clothing, wash immediately with soap and water.

- (3) Coat threads of elbows (2, 3, 5, and 6) with pipe thread sealing compound.
- (4) Install elbows (2 and 3) to elbows (5 and 6).
- (5) Connect fuel lines (7 and 8) to elbows (2 and 5).

NOTE

There are two models of fuel-water separators. Model A has two wires connected at the bowl. Model B has two wires at the back of the cylinder ring. Do step (6) for Model A. Do step (6.1) for Model B.

- (6) Connect electrical wires (9) to terminals (11) in fuel-water separator (4).
- (6.1) Connect fuel-water separator wire (9.1) to harness wire (9.2) with connector (9.3).

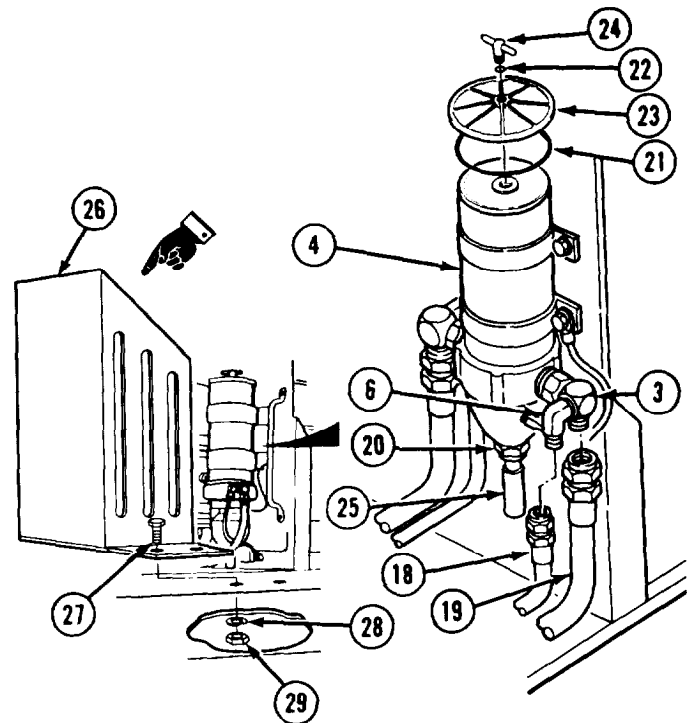
NOTE

- Ground wires and lockwasher should be installed on bottom right screw.
- Some vehicles have nuts, lockwashers, and screws. Others have flanged nuts and screws.

- (7) Attach fuel-water separator (4) to tire carrier (12) using four screws (13), two lockwashers (14), ground wire (10), four washers (15), three lockwashers (16), and four nuts (17).

Fuel System Maintenance Instructions (Cont)

- (8) Connect fuel lines (18 and 19) to elbows (3 and 6).
- (9) Close drain valve (20).
- (10) Pour clean fuel in fuel-water separator (4) until full.
- (11) Wet preformed packing (21) with fuel.
- (12) Install preformed packings (21 and 22), lid (23), and T-handle (24).
- (13) Install drain hose (25) on drain valve (20).



NOTE

Model B has a guard that protects the fuel-water separator. Do step (14) for Model B.

- (14) Install guard (26) with three screws (27), lockwashers (28), and nuts (29).

f. Follow-on Maintenance.

- (1) Start engine (TM 9-2320-279-10).
- (2) Check fuel-water separator connections for leaks.
- (3) Shut off engine (TM 9-2320-279-10).

END OF TASK

4-11. SECONDARY FUEL FILTER REMOVAL/INSTALLATION

This task covers:

- a. Removal
- b. Installation

c. Follow-on Maintenance

INITIAL SETUP

Models
All

Test Equipment
None

Special Tools
None

Supplies
Oil, fuel, diesel, Item 27, Appendix C

Personnel Required
MOS 63S, Heavy wheel vehicle mechanic

References
None

Equipment Condition

| TM or Para | Condition Description |
|------------------|-------------------------------|
| TM 9-2320-279-10 | Shut off engine. Engine cool. |
| TM 9-2320-279-10 | Spare tire removed. |
| TM 9-2320-279-10 | Engine side panel removed. |

Special Environmental Conditions
None

General Safety Instructions
No smoking or flames.
Fire extinguisher within reach.

Fuel System Maintenance Instructions (Cont)

4-11. SECONDARY FUEL FILTER REMOVAL/INSTALLATION (CONT).

a. Removal.

NOTE

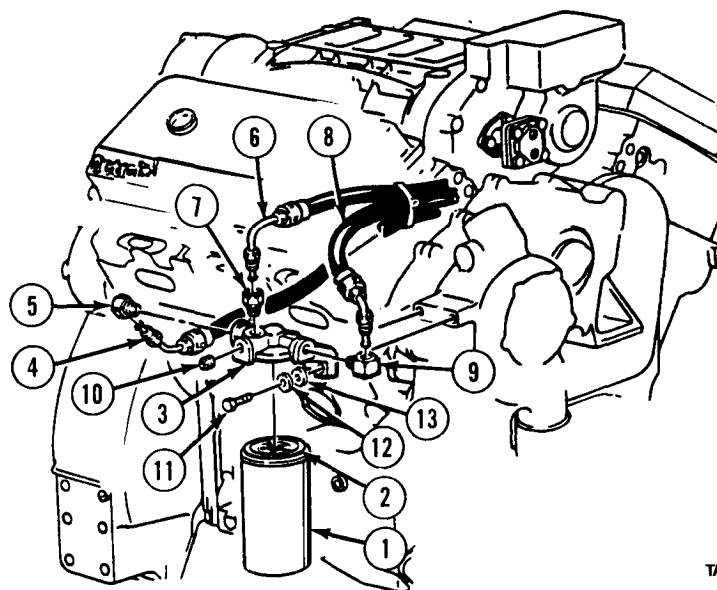
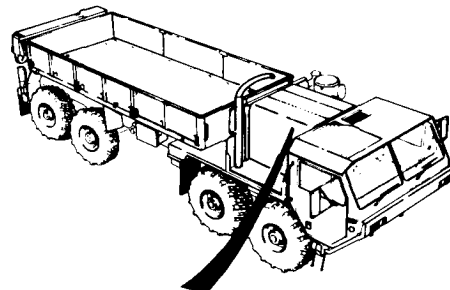
Secondary fuel filter is a spin-on type.

- (1) Remove filter element (1) and gasket (2) from housing (3).

NOTE

Remove housing only if replacement is necessary.

- (2) Remove fuel line (4) and elbow (5) from housing (3).
- (3) Remove fuel line (6) and bushing (7) from housing (3).
- (4) Remove fuel line (8) and elbow (9) from housing (3).
- (5) Remove plug (10), two screws (11), lockwashers (12), washers (13), and housing (3).



TA185482

b. Installation.

NOTE

Follow steps (1) through (5) only if new housing is to be installed.

- (1) Install housing (3) with two screws (11), lockwashers (12), and washers (13).
- (2) Install plug (10).
- (3) Install elbow (5) and connect fuel line (4).
- (4) Install bushing (7) and connect fuel line (6).
- (5) Install elbow (9) and connect fuel line (8).
- (6) Fill filter element (1) with fuel.
- (7) Moisten gasket (2) with fuel.
- (8) Install filter element (1) and gasket (2) on housing (3). Hand tighten filter element.

c. Follow-on Maintenance.

- (1) Start engine and check operation (TM 9-2320-279-10).
- (2) Check fuel filters for leaks.
- (3) Shut off engine (TM 9-2320-279-10).
- (4) Install engine side panel (TM 9-2320-279-10).
- (5) Install spare tire (TM 9-2320-279-10).

END OF TASK

Fuel System Maintenance Instructions (Cont)

Section VI. ENGINE STARTING AID

4-12. ETHER STARTING AID REMOVAL/INSTALLATION.

This task covers:

- a. Removal
- b. Installation

c. Follow-on Maintenance

INITIAL SETUP

Models

All

Test Equipment

None

Special Tools

None

Supplies

None

Personnel Required

MOS 63S, Heavy wheel vehicle mechanic

References

None

Equipment Condition

| <i>TM or Para</i> | <i>Condition Description</i> |
|-------------------|------------------------------|
| TM 9-2320-279-10 | Shut off engine. |

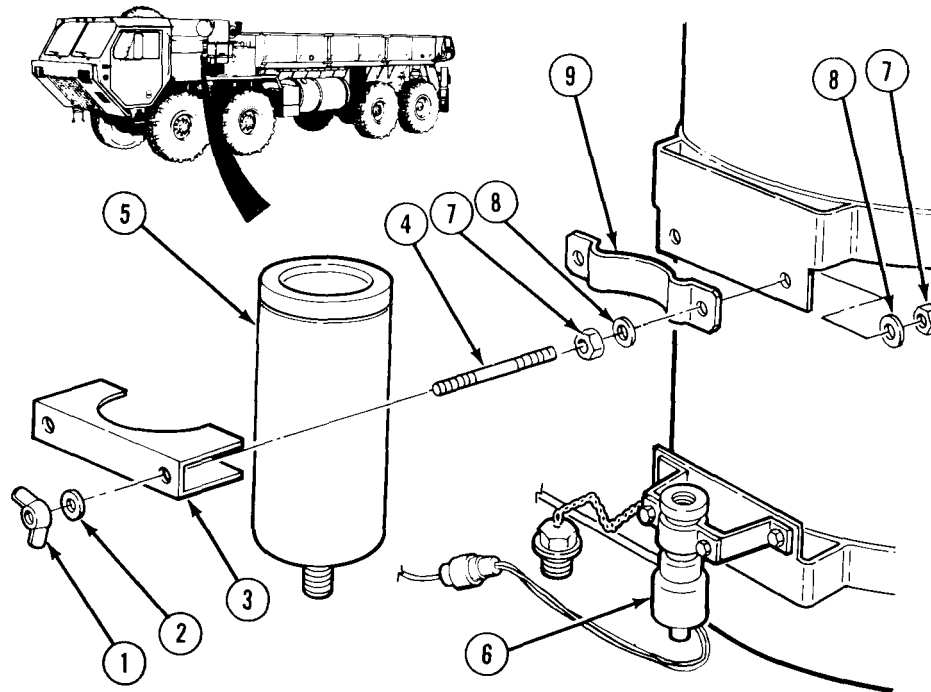
Special Environmental Conditions

None

General Safety Instructions

No smoking or flames.

a. Removal.

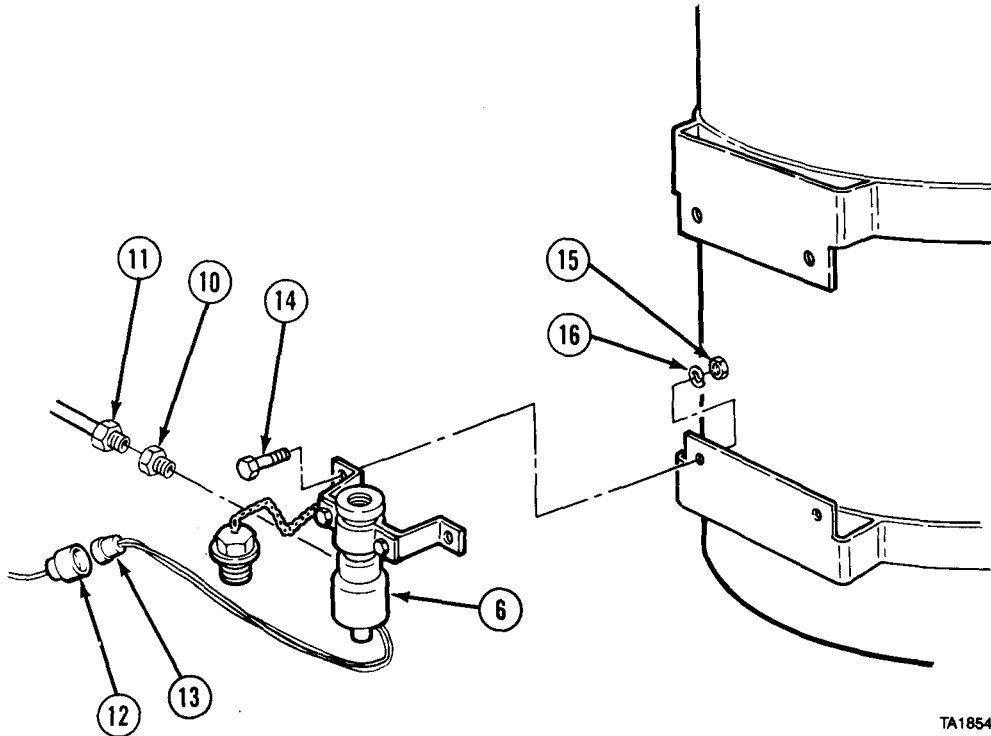


TA185478

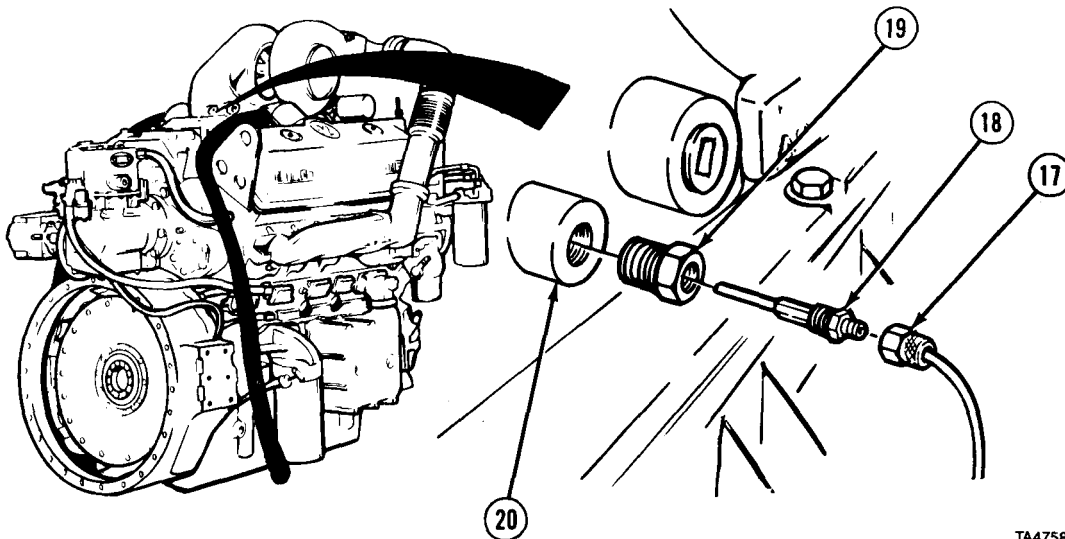
- (1) Remove two wingnuts (1), washers (2), and bracket (3) from studs (4).
- (2) Remove cylinder (5) from valve (6).
- (3) Remove two studs (4), four nuts (7), lockwashers (8), and clamp (9).

Fuel System Maintenance Instructions (Cont)

4-12. ETHER STARTING AID REMOVAL/INSTALLATION (CONT).



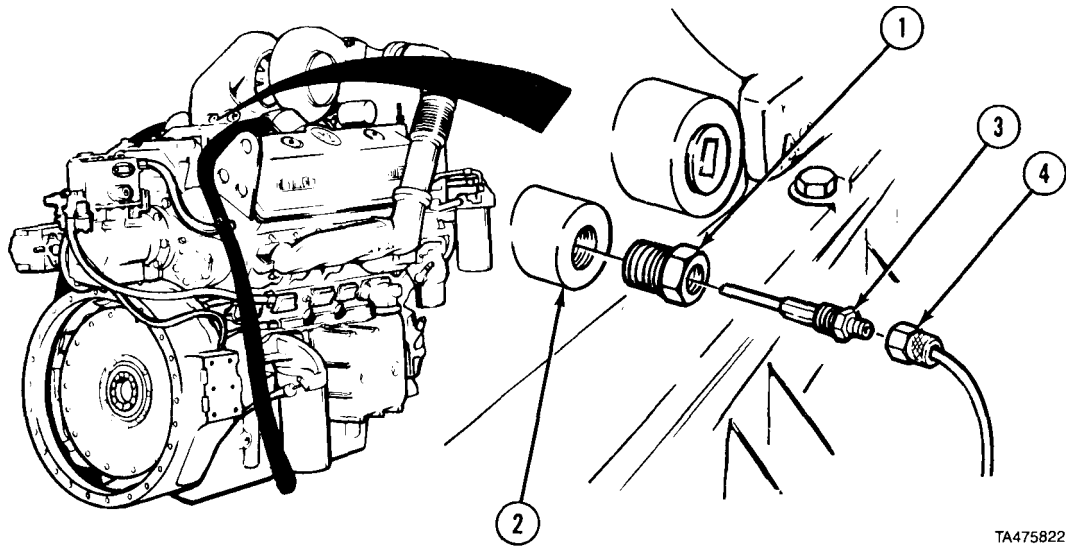
- (4) Disconnect fitting (10) and ether line (11) from valve (6).
- (5) Disconnect receptacle (12) from electrical connector (13).
- (6) Remove two screws (14), nuts (15), lockwashers (16), and valve (6).



- (7) Disconnect fitting (17) from atomizer (18).
- (8) Remove atomizer (18) from reducer (19).
- (9) Remove reducer (19) from blower (20).

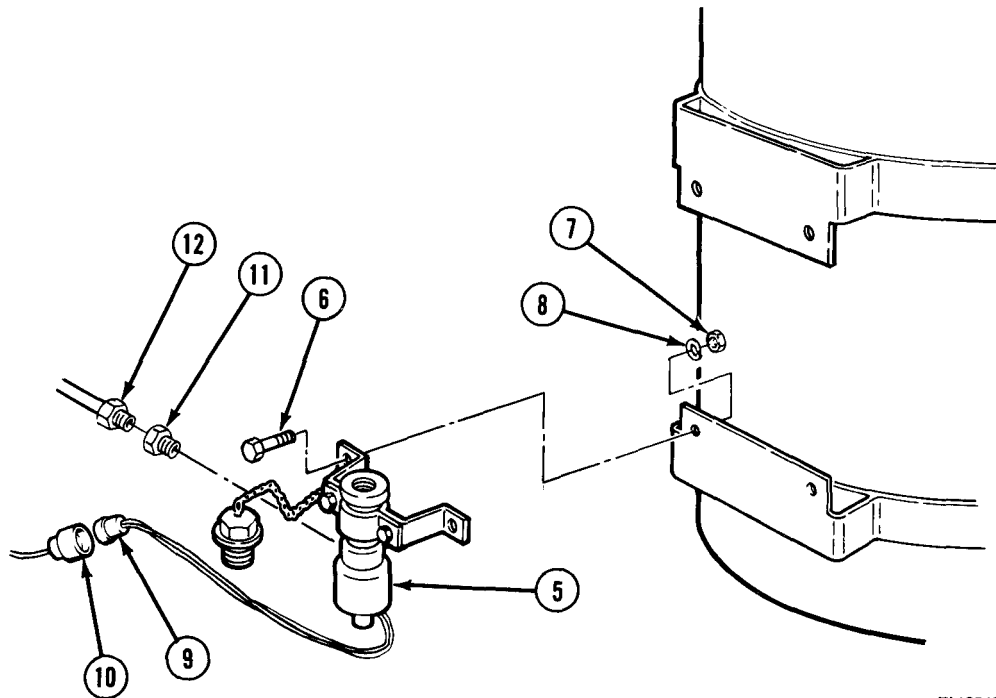
Fuel System Maintenance Instructions (Cont)

b. Installation.



TA475822

- (1) Install reducer (1) in blower (2).
- (2) Install atomizer (3) in reducer (1).
- (3) Connect fitting (4) to atomizer (3).

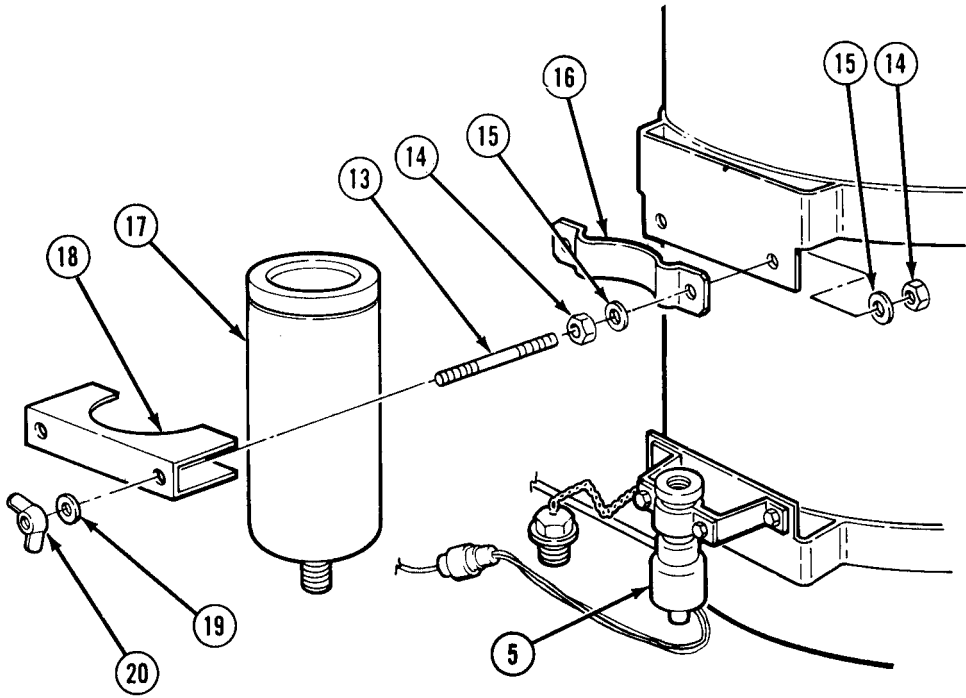


TA185481

- (4) Install valve (5) with two screws (6), nuts (7), and lockwashers (8).
- (5) Connect electrical connector (9) in receptacle (10).
- (6) Connect fitting (11) and ether line (12) to valve body (5).

Fuel System Maintenance Instructions (Cont)

4-12. ETHER STARTING AID REMOVAL/INSTALLATION (CONT).



TA185480

- (7) Install two studs (13) with four nuts (14), lockwashers (15), and clamp (16).
- (8) Install cylinder (17) on valve (5).
- (9) Install bracket (18), two washers (19), and wingnuts (20) on studs (13).

c. *Follow-on Maintenance.* Check operation of ether starting aid (TM 9-2320-279-10).

END OF TASK

Fuel System Maintenance Instructions (Cont)

Section VII. THROTTLE CONTROLS

4-13. THROTTLE TREADLE VALVE TESTING.

This task covers:

- a. Testing
- b. Follow-on Maintenance

INITIAL SETUP

Models

All

References

None

Test Equipment

None

Equipment Condition

| <i>TM or Para</i> | <i>Condition Description</i> |
|-------------------|---|
| TM 9-2320-279-10 | Air system pressurized to 90 psi (621 kPa) minimum. |
| TM 9-2320-279-10 | Shut off engine. |

Special Tools

None

Special Environmental Conditions

None

Supplies

None

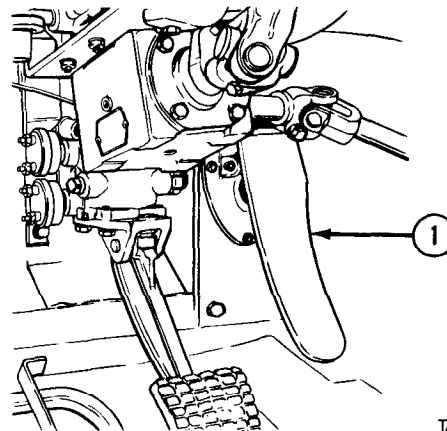
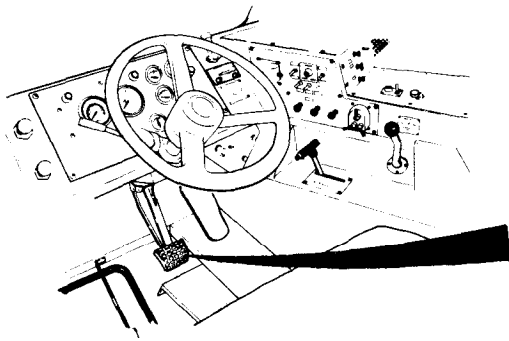
Personnel Required

MOS 63S, Heavy wheel vehicle mechanic

General Safety Instructions

None

a. Testing.



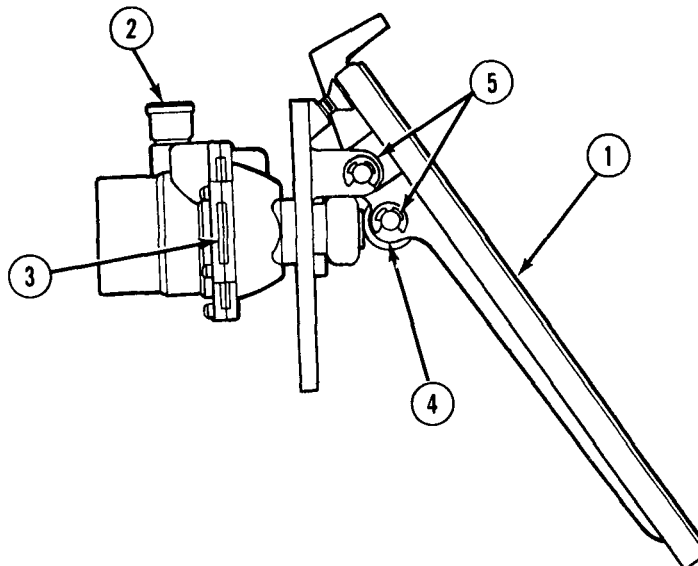
TA182291

- (1) Press throttle treadle valve (1) by hand. Throttle treadle valve action should be smooth without binding.
- (2) Release throttle treadle valve (1). Throttle treadle valve should return at once without sticking.

Fuel System Maintenance Instructions (Cont)

4-13. THROTTLE TREADLE VALVE TESTING (CONT).

- (3) If air comes out of exhaust port (2) when throttle treadle valve (1) is pressed, or if there are air leaks at seam (3) of valve body, replace throttle treadle valve (para 4-14).
- (4) Inspect roller (4) for freedom of movement.
- (5) Inspect all fasteners and retaining rings (5) to make sure fasteners and retaining rings are correctly installed.
- (6) If throttle treadle valve operation is sticky or other mechanical defects are found, replace throttle treadle valve (para 4-14).



TA182313

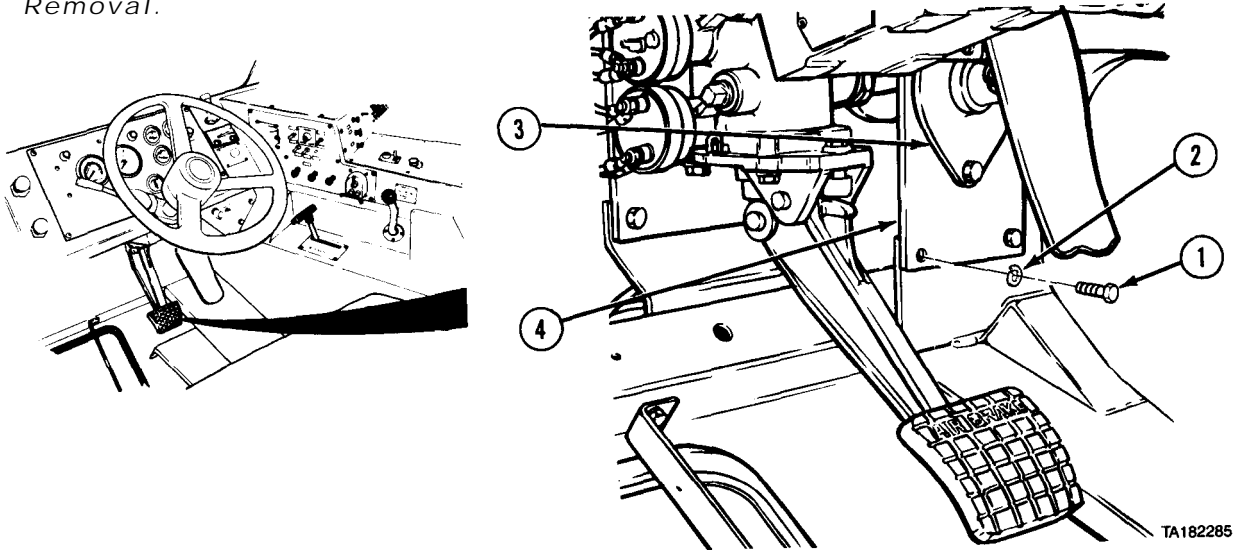
b. Follow-on Maintenance.

END OF TASK

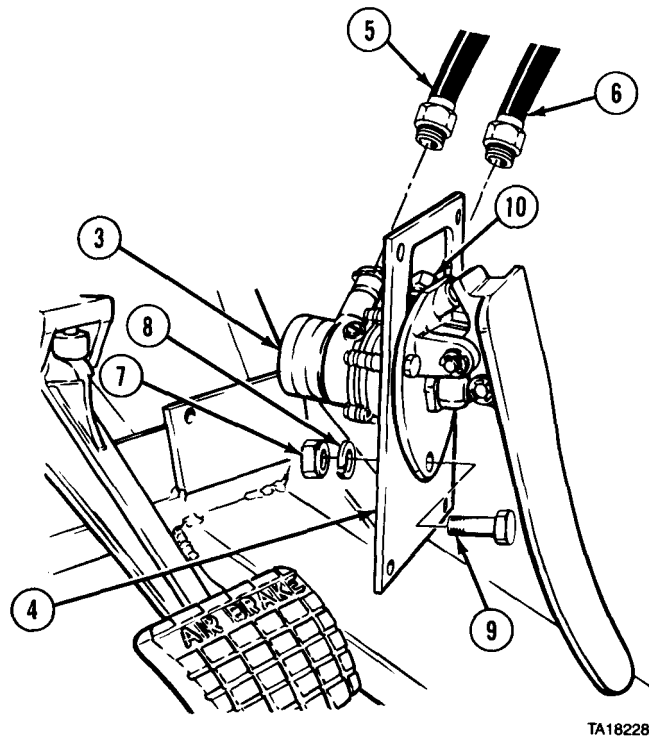
| | |
|---|--|
| 4-14. THROTTLE TREADLE VALVE REMOVAL/INSTALLATION. | |
| This task covers: | |
| a. Removal | c. Follow-on Maintenance |
| b. Installation | |
| INITIAL SETUP | |
| <i>Models</i> | <i>References</i> |
| All | None |
| <i>Test Equipment</i> | <i>Equipment Condition</i> |
| None | <i>TM or Para</i> <i>Condition Description</i> |
| <i>Special Tools</i> | TM 9-2320-279-10 Shut off engine. |
| None | TM 9-2320-279-10 Air system drained. |
| <i>Supplies</i> | <i>Special Environmental Conditions</i> |
| Compound, sealing, pipe thread, Item 18, Appendix C | None |
| Tags, identification, Item 48, Appendix C | <i>General Safety Instructions</i> |
| <i>Personnel Required</i> | None |
| MOS 63S, Heavy wheel vehicle mechanic | |

Fuel System Maintenance Instructions (Cont)

a. Removal.



(1) Remove four screws (1) and lockwashers (2) from throttle treadle valve (3) and bracket (4).



(2) Pull throttle treadle valve (3) and bracket (4) away from cab.

NOTE

Tag and mark air lines before removing.

(3) Disconnect two air lines (5 and 6).

(4) Remove three nuts (7), lockwashers (8), screws (9), and throttle treadle valve (3).

(5) Remove two fittings (10).

Fuel System Maintenance Instructions (Cont)

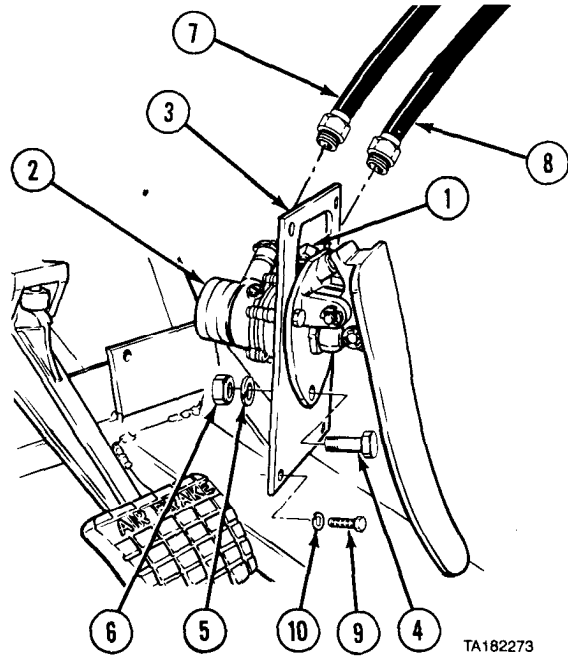
4-14. THROTTLE TREADLE VALVE REMOVAL/INSTALLATION (CONT).

b. Installation.

WARNING

Adhesives, solvents, and sealing compounds can burn easily, can give off harmful vapors, and are harmful to skin and clothing. To avoid injury or death, keep away from open fire and use in well-ventilated area. If adhesive, solvent, or sealing compound gets on skin or clothing, wash immediately with soap and water.

- (1) Apply pipe thread sealing compound and install two fittings (1).
- (2) Install throttle treadle valve (2) to bracket (3) with three screws (4), lockwashers (5), and nuts (6).
- (3) Position throttle treadle valve (2) and bracket (3) in cab. Connect air lines (7 and 8) to throttle treadle valve.
- (4) Install throttle treadle valve (2) and bracket (3) to cab with four screws (9) and lockwashers (10).



c. Follow-on Maintenance. Test throttle treadle valve (para 4-13).

END OF TASK

Fuel System Maintenance Instructions (Cent)

4-15. ENGINE HIGH IDLE PRESSURE REGULATOR AND SOLENOID
REMOVAL/REPAIR/INSTALLATION/ADJUSTMENT (M984).

This task covers:

- | | |
|----------------|--------------------------|
| a. Removal | d. Installation |
| b. Disassembly | e. Adjustment |
| c. Assembly | f. Follow-on Maintenance |

INITIAL SETUP

Models
M984

Test Equipment
None

Special Tools
None

supplies
Connectors, electrical, butt, Item 19,
Appendix C
Compound, sealing, pipe thread, Item 18,
Appendix C
Tags, identification, Item 48, Appendix C

Personnel Required
MOS 63S, Heavy wheel vehicle mechanic

References
None

Equipment Condition

| <i>TM or Para</i> | <i>Condition</i> | <i>Description</i> |
|-------------------|---------------------------------|--------------------|
| TM 9-2320-279-10 | Air system drained. | |
| Para 7-91 | Batteries disconnected. | |
| TM 9-2320-279-10 | Engine left side panel removed. | |
| Para 6-11 | Fan removed. | |

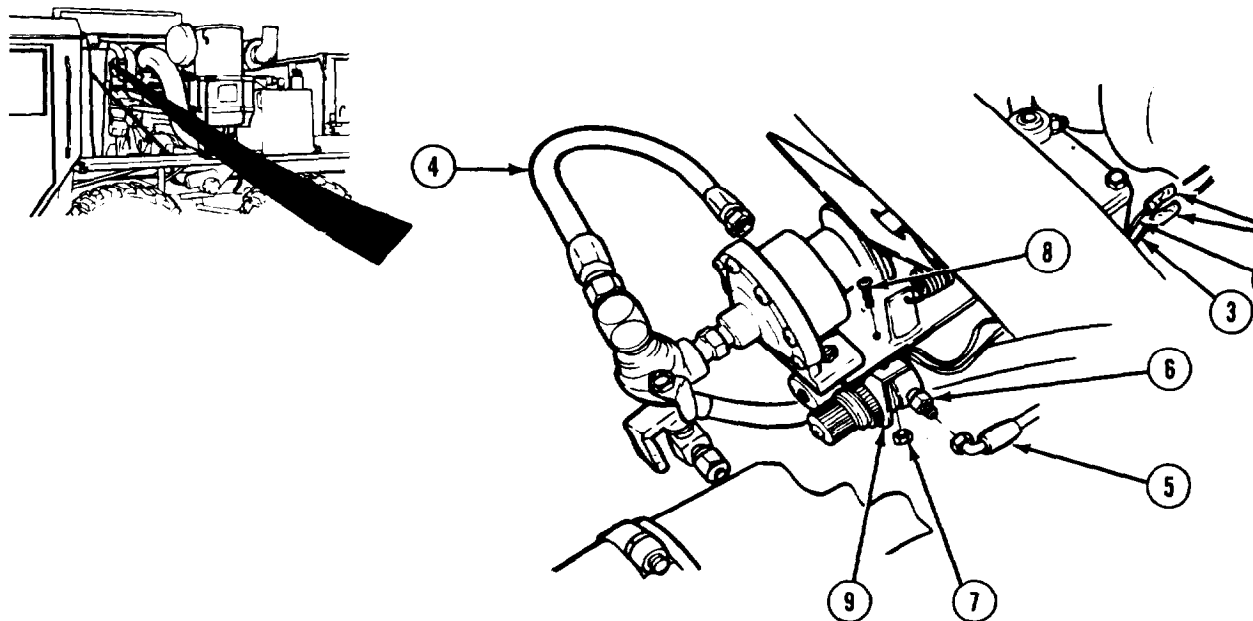
Special Environmental Conditions
None

General Safety Instructions
None

Fuel System Maintenance Instructions (Cont)

4-15. ENGINE HIGH IDLE PRESSURE REGULATOR AND SOLENOID REMOVAL/REPAIR/INSTALLATION/ADJUSTMENT (M984) (CONT).

a. Removal.



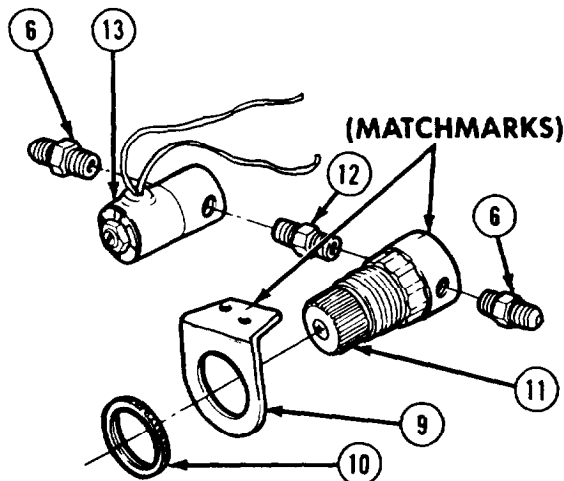
NOTE

- Tag and mark all wires before removing.
- There are two models of pressure regulators. Model A uses a screw to lock knob in place. Model B has a push-to-lock knob. Removal procedure is the same for both models. Model A is illustrated.

- (1) Cut two butt connectors (1) on wires (2 and 3).
- (2) Disconnect two air lines (4 and 5) from two fittings (6).
- (3) Remove two locknuts (7), screws (8), and bracket (9).

NOTE

- Matchmark position of pressure regulator.
 - There are two types of pressure regulators. One type has two ports. Other type has four ports, two of which are plugged.
- (4) Remove nut (10) and bracket (9) from pressure regulator (11).
 - (5) Remove two fittings (6) and fitting (12) from pressure regulator (11) and solenoid (13).



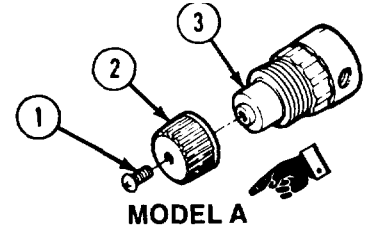
Fuel System Maintenance Instructions (Cont)

NOTE

Model A pressure regulator uses a screw to lock knob in place. Model B has a push-to-lock knob. Disassembly and assembly procedures only apply to Model A.

b. Disassembly. Remove screw (1) and knob (2) from pressure regulator (3).

c. Assembly. Install knob (2) on pressure regulator (3) with screw (1).



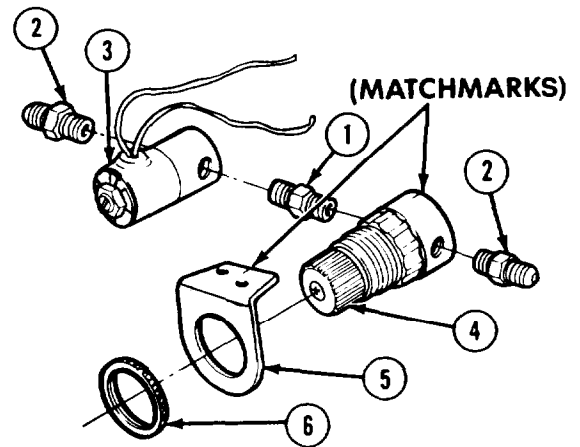
d. Installation.

WARNING

Adhesives, solvents, and sealing compounds can burn easily, can give off harmful vapors, and are harmful to skin and clothing. To avoid injury or death, keep away from open fire and use in well-ventilated area. If adhesive, solvent, or sealing compound gets on skin or clothing, wash immediately with soap and water.

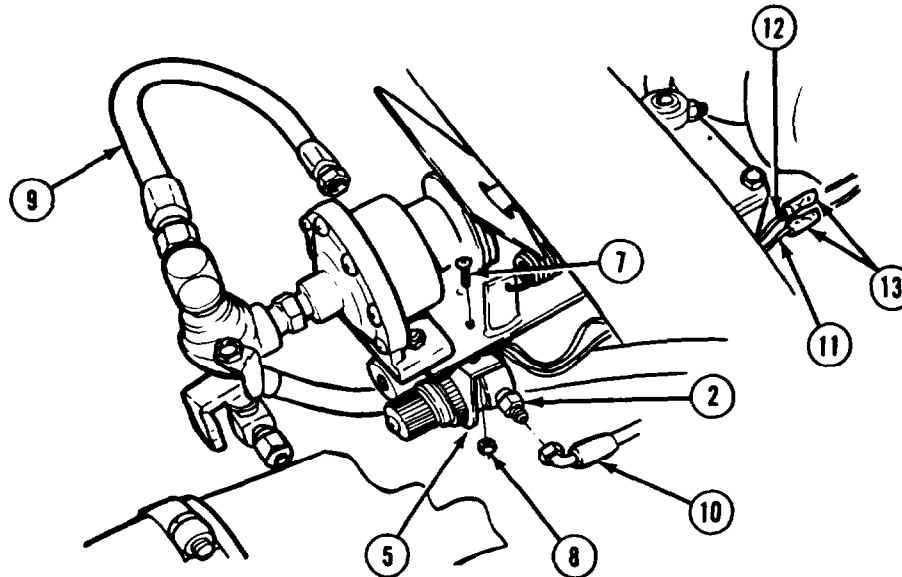
NOTE

- There are two models of pressure regulators. Model A uses a screw to lock knob in place. Model B has a push-to-lock knob. Installation procedure is the same for both models. Model A is illustrated.
 - One model has two ports. The other model has four ports, two of which are plugged.
- (1) Coat threads of fitting (1) and two fittings (2) with pipe thread sealing compound.
 - (2) Install fitting (1) and two fittings (2) on solenoid (3) and pressure regulator (4).
 - (3) Aline matchmarks and install bracket (5) on pressure regulator (4) with nut (6).



Fuel System Maintenance Instructions (Cont)

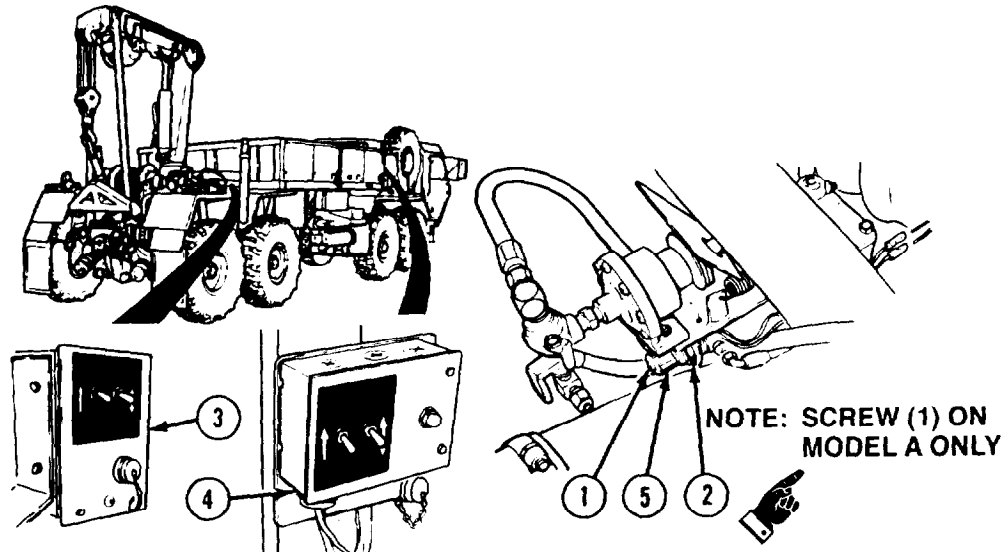
**4-15. ENGINE HIGH IDLE PRESSURE REGULATOR AND SOLENOID
REMOVAL/REPAIR/INSTALLATION/ADJUSTMENT (M984) (CONT).**



- (4) Install bracket (5) with two screws (7) and locknuts (8).
- (5) Install two air lines (9 and 10) on fittings (2).
- (6) Connect two wires (11 and 12) with electrical butt connectors (13).

Fuel System Maintenance Instructions (Cont)

e. Adjustment.

**NOTE**

There are two models of pressure regulators. Model A uses a screw to lock knob in place. Model B has a push-to-lock knob. Do step (1) for Model A. Do step (1.1) for Model B.

- (1) Loosen screw (1) on pressure regulator (2).
- (1.1) Pull outward on knob (5) of pressure regulator (2).

WARNING

Stay clear of engine fan belts. Do not wear loose clothing, long sleeves or jewelry. Stay clear of hot exhaust manifold. Failure to do so could cause severe injury or death.

- (2) Connect batteries (para 7-91).
- (3) Start engine (TM 9-2320-279-10).
- (4) Engage PTO switch (TM 9-2320-279-10).
- (5) Activate high idle at ENGINE HIGH IDLE box (3 or 44) (TM 9-2320-354-10).

NOTE

After each turn of knob, wait a few seconds for engine to catch up to adjustment. Adjustment should be as close to 900 rpm as possible.

- (6) Turn knob (5) slowly until rpms read between 800 and 900.

NOTE

Do step (7) for Model A. Do step (7.1) for Model B.

- (7) Tighten screw (1) on pressure regulator (2).
- (7.1) Push knob (5) in to lock setting of pressure regulator (2).
- (8) Check rpm setting. If over 900 rpm, repeat steps (1) through (7.1).
- (9) Shut off engine (TM 9-2320-279-10).

f . **Follow-on Maintenance.**

- (1) Install fan (para 6-11).
- (2) Start engine and build up air pressure (TM 9-2320-279-10).
- (3) Check for air leaks.
- (4) Shut off engine (TM 9-2320-279-10).
- (5) Install engine left side panel (TM 9-2320-279-10).
- (6) Close engine side panel (TM 9-2320-279-10).

END OF TASK

Fuel System Maintenance Instructions (Cent)

4-16. THROTTLE AIR SOLENOID CHECK VALVE **REMOVAL/INSTALLATION (M984).**

This task covers:

- a. Removal
- b. Installation

c. Follow-on Maintenance

INITIAL SETUP

Models

M984

Test Equipment

None

Special Tools

None

Supplies

Compound, sealing, pipe thread, Item 18, Appendix C
Tags, identification, Item 48, Appendix C

Personnel Required

MOS 63S, Heavy wheel vehicle mechanic

References

None

Equipment Condition

| TM or Para | Condition Description |
|------------------|---------------------------------|
| TM 9-2320-279-10 | Shut off engine. |
| TM 9-2320-279-10 | Engine left side panel removed. |
| TM 9-2320-279-10 | Air system drained. |

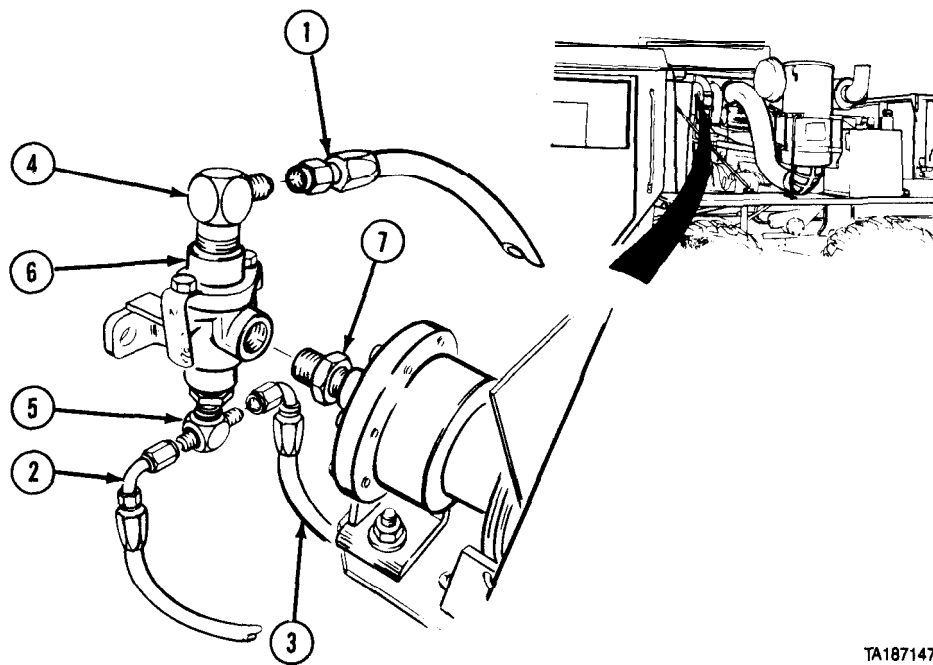
Special Environmental Conditions

None

General Safety Instructions

None

a. Removal.



TA187147

NOTE

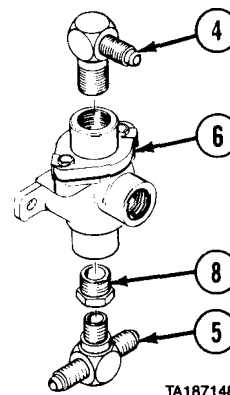
Tag and mark all wires before disconnecting.

- (1) Disconnect three air lines (1, 2, and 3) from elbow (4) and tee (5).
- (2) Remove check valve (6) from fitting (7).

Fuel System Maintenance Instructions (Cont)

14-16. THROTTLE AIR SOLENOID CHECK VALVE REMOVAL/INSTALLATION (M984) (CONT).

(3) Remove elbow (4), tee (5), and fitting (8) from check valve (6)

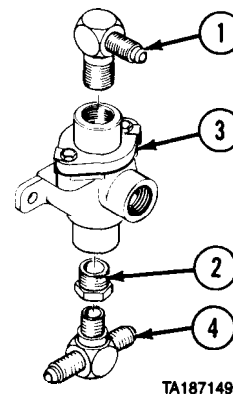


b. Installation.

WARNING

Adhesives, solvents, and sealing compounds can burn easily, can give off harmful vapors, and are harmful to skin and clothing. To avoid injury or death, keep away from open fire and use in well-ventilated area. If adhesive, solvent, or sealing compound gets on skin or clothing, wash immediately with soap and water.

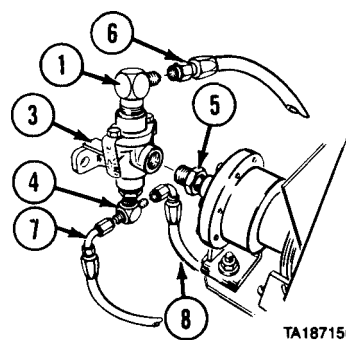
- (1) Coat threads of elbow (1) and fitting (2) with pipe thread sealing compound and install in check valve (3).
- (2) Coat threads of tee (4) with pipe thread sealing compound and install in fitting (2).
- (3) Coat threads of fitting (5) with pipe thread sealing compound and install check valve (3) on fitting.
- (4) Connect three air lines (6, 7, and 8) to tee (4) and elbow (1).



c. Follow-on Maintenance.

- (1) Start engine and build air pressure (TM 9-2320-279-10).
- (2) Check for air leaks.
- (3) Shut off engine (TM 9-2320-279-10).
- (4) Install engine left side panel (TM 9-2320-279-10).

END OF TASK



CHAPTER 5 EXHAUST SYSTEM MAINTENANCE

| Contents | Para | Page |
|--|------|------|
| General..... | 5-1 | 5-1 |
| Muffler Assembly Removal/Installation..... | 5-2 | 5-1 |

Section I. INTRODUCTION

5-1. GENERAL. This chapter contains maintenance instructions for removing and installing exhaust system components authorized by the maintenance allocation chart (MAC) at the organizational maintenance level.

Section- II. MUFFLER

Exhaust System Maintenance Instructions

5-2. MUFFLER ASSEMBLY REMOVAL/INSTALLATION.

This task covers:

- | | |
|---|--|
| <ul style="list-style-type: none"> a. Removal b. Installation | <ul style="list-style-type: none"> c. Follow-on Maintenance |
|---|--|

INITIAL SETUP

Models
All

Test Equipment
None

Special Tools
None

Supplies
None

Personnel Required
MOS 63S, Heavy wheel vehicle mechanic

References
None

Equipment Condition

| <i>TM or Para</i> | <i>Condition Description</i> |
|-------------------|------------------------------|
| TM 9-2320-279-10 | Shut off engine. |
| TM 9-2320-279-10 | Engine cover open. |

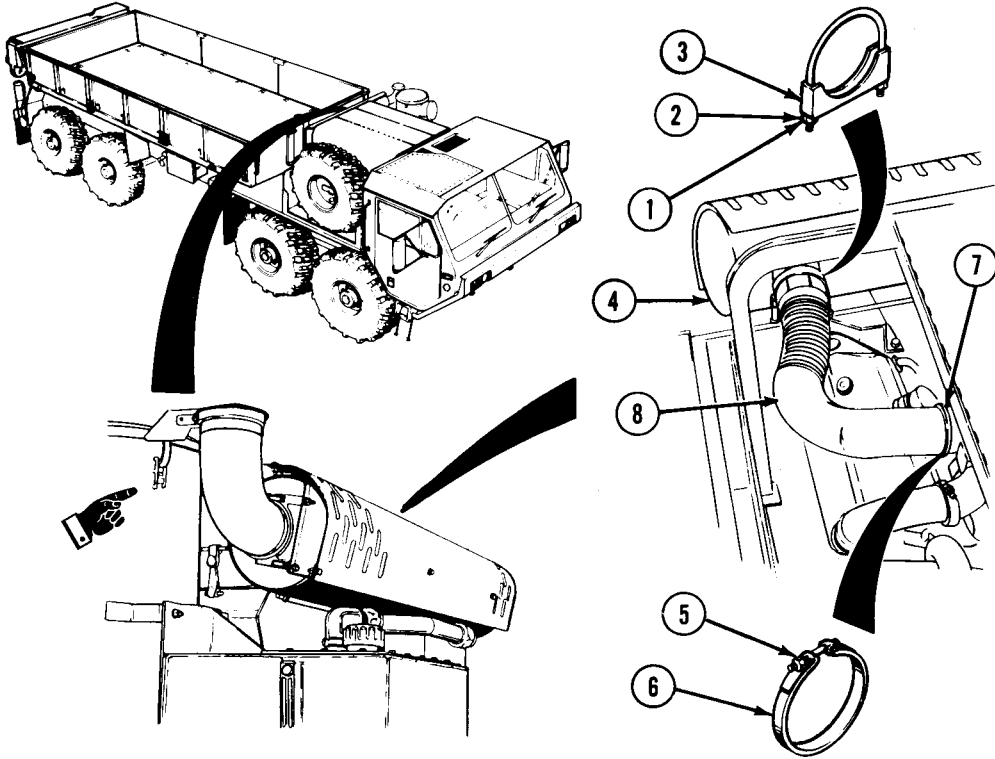
Special Environmental Conditions
None

General Safety Instructions
Allow muffler and exhaust pipes to cool before removing.

Exhaust System Maintenance Instructions (Cont)

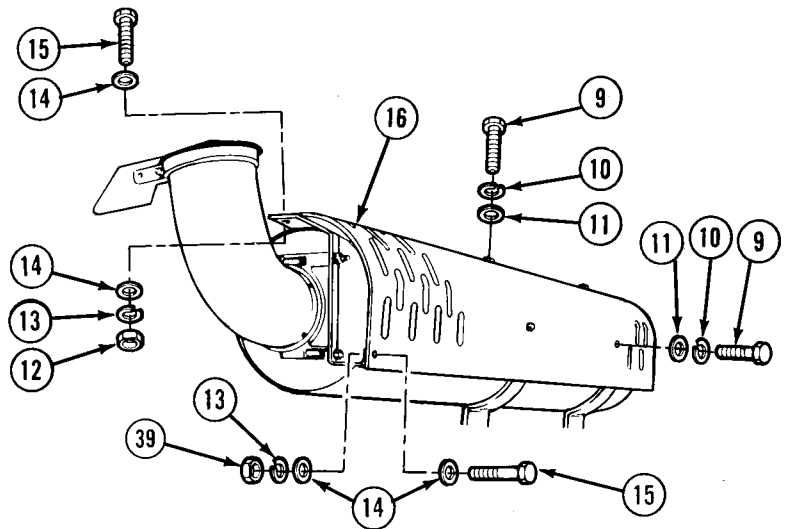
5-2. MUFFLER ASSEMBLY REMOVAL/INSTALLATION (CONT).

a. Removal.



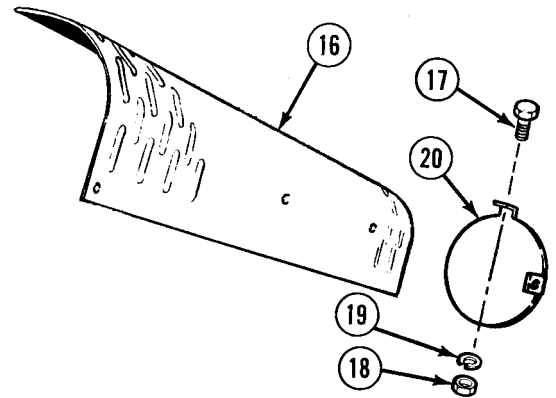
- (1) Remove two nuts (1) and washers (2). Remove clamp (3) from muffler (4).
- (2) Remove nut (5) and clamp (6) from turbocharger (7).
- (3) Pull exhaust pipe (8) from turbocharger (7).
- (4) Remove exhaust pipe (8) from muffler (4).

- (5) Remove four screws (9), lockwashers (10), and washers (11).
- (6) Remove two nuts (12), two lockwashers (13), four washers (14), and two screws (15). Remove muffler guard (16).

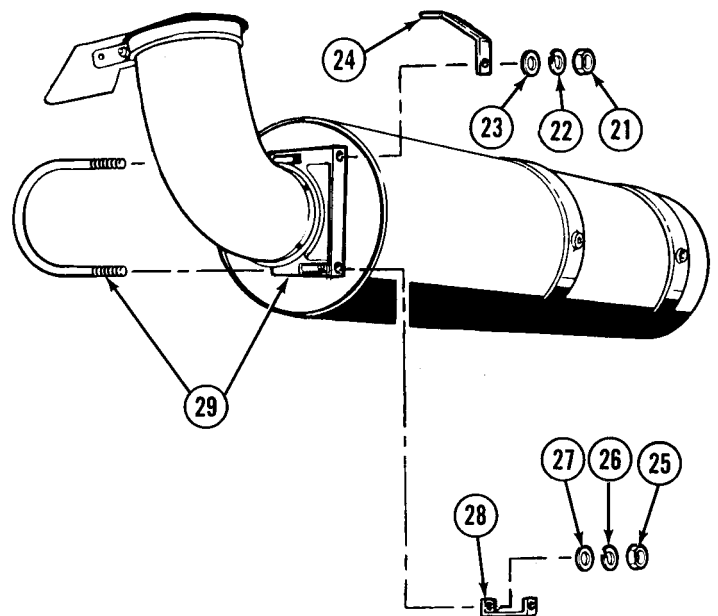


Exhaust System Maintenance Instructions (Cont)

- (7) Remove two screws (17), nuts (18), and lockwashers (19). Remove end muffler guard (20) from muffler guard (16).



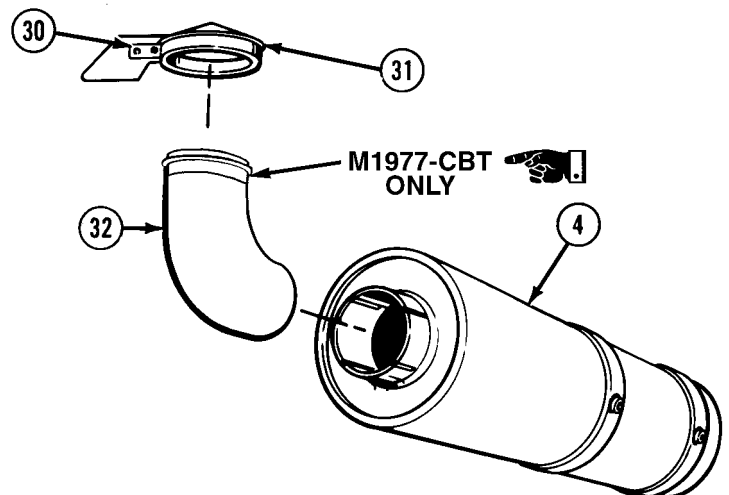
- (8) Remove two nuts (21), lockwashers (22), washers (23), and guard support bracket (24).
- (9) Remove nut (25), lockwasher (26), washer (27), and guard support bracket (28).
- (10) Remove clamp (29).



NOTE

Flanged exhaust tail pipe is used on M1977-CBT only. All others do not use a flange.

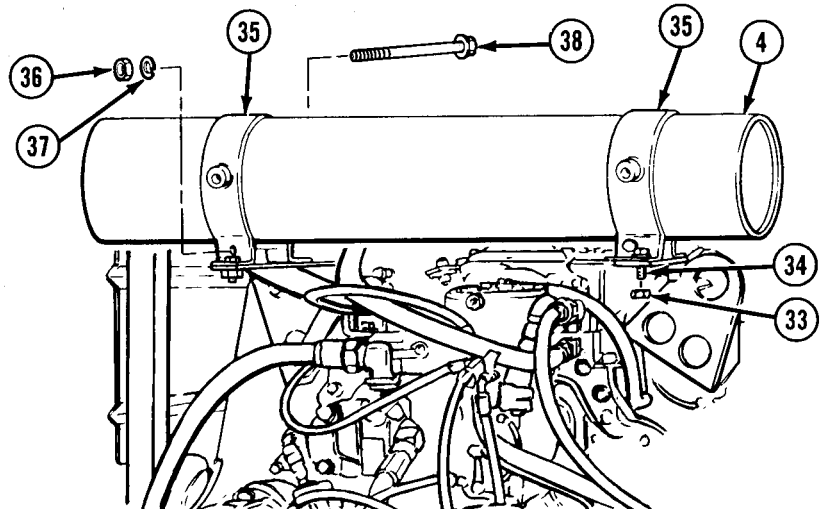
- (11) Loosen nut (30) and remove rain cap (31) from exhaust tail pipe (32).
- (12) Remove exhaust tail pipe (32) from muffler (4).



Exhaust System Maintenance Instructions (Cont)

5-2. MUFFLER ASSEMBLY REMOVAL/INSTALLATION (CONT).

- (13) Remove four nuts (33) and four screws (34) at base of muffler strap clamps (35). Remove muffler (4) and muffler strap clamps (35).
- (14) Remove two nuts (36), lockwashers (37), and screws (38) from muffler strap clamps (35).
- (15) Remove muffler strap clamps (35).



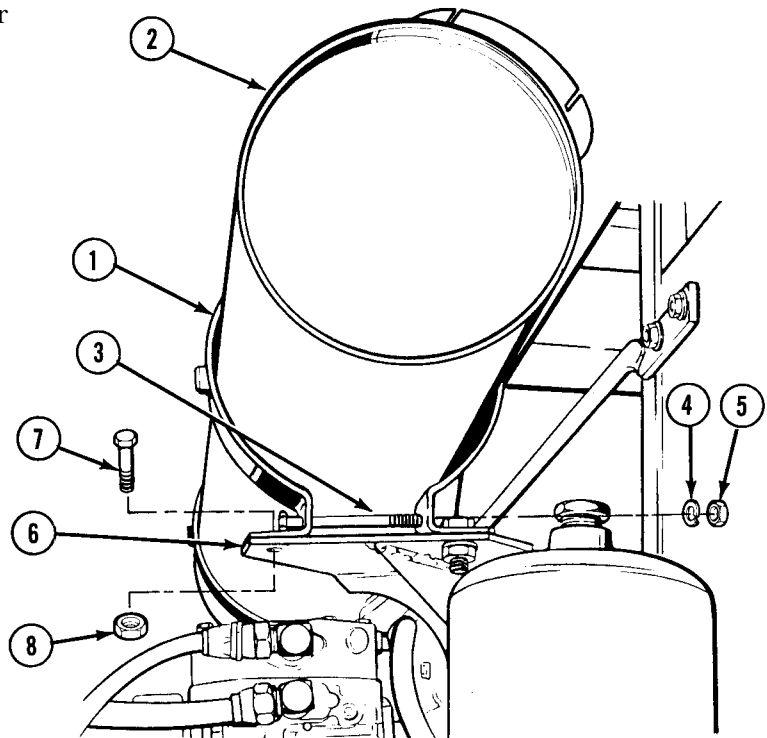
b. Installation.

- (1) Slide muffler strap clamps (1) over muffler (2).
- (2) Install, but do not tighten, two screws (3), lockwashers (4), and nuts (5).

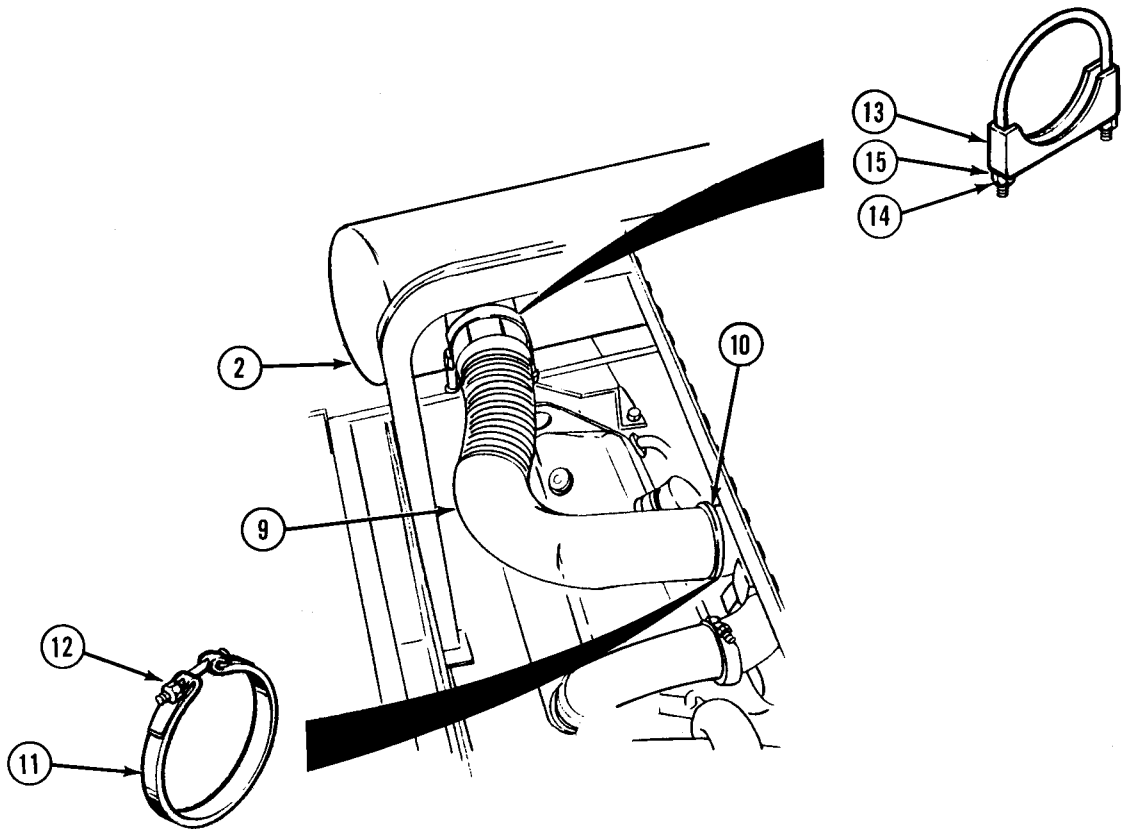
NOTE

Muffler strap clamps must be positioned so nuts will face rear of vehicle when muffler is installed.

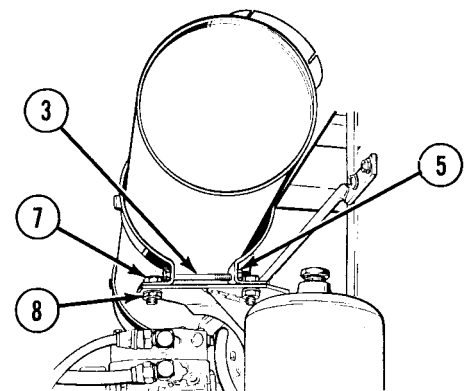
- (3) Set muffler (2) with muffler strap clamps (1) on brackets (6). Install four screws (7) and nuts (8), but do not tighten.



Exhaust System Maintenance Instructions (Cont)



- (4) Aline and attach exhaust pipe (9) to muffler (2) and turbocharger (10).
- (5) Install clamp (11) with nut (12).
- (6) Install clamp (13) with two nuts (14) and washers (15).
- (7) Tighten nuts (5) on screws (3) and nuts (8) on screws (7).



Exhaust System Maintenance Instructions (Cont)

5-2. MUFFLER ASSEMBLY REMOVAL/INSTALLATION (CONT).

NOTE

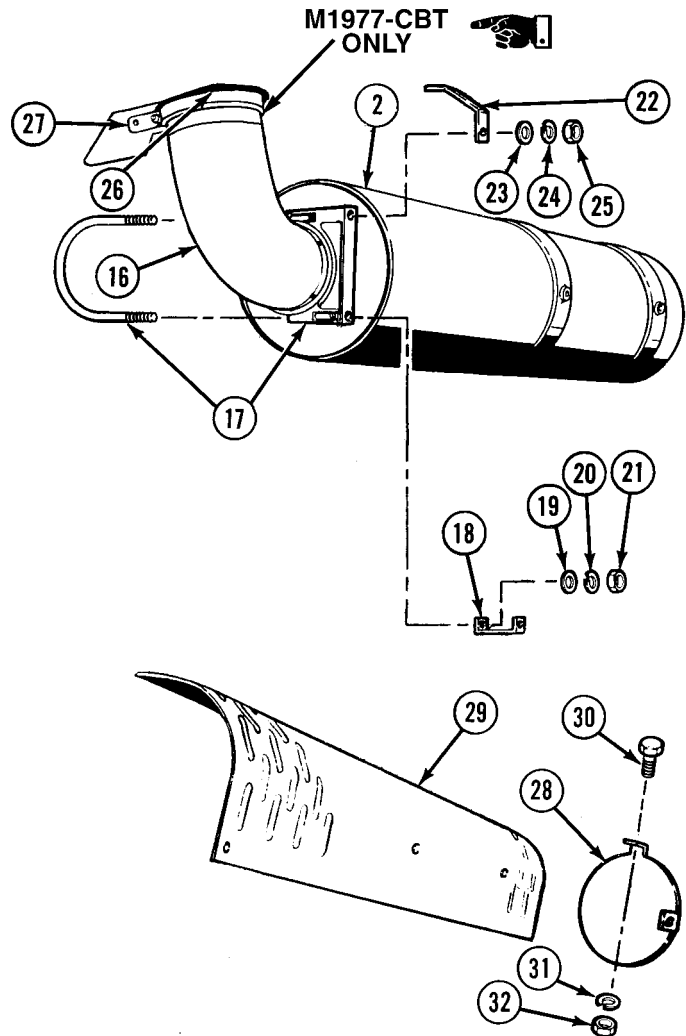
Flanged exhaust tail pipe is used on M1977-CBT only. All others do not use a flange.

- (8) Install exhaust pipe (16) in muffler (2).
- (9) Install clamp (17).
- (10) Install guard support bracket (18), washer (19), lockwasher (20), and nut (21) on clamp (17). Do not tighten.
- (11) Install guard support bracket (22), washer (23), lockwasher (24), and two nuts (25) on clamp (17). Do not tighten.

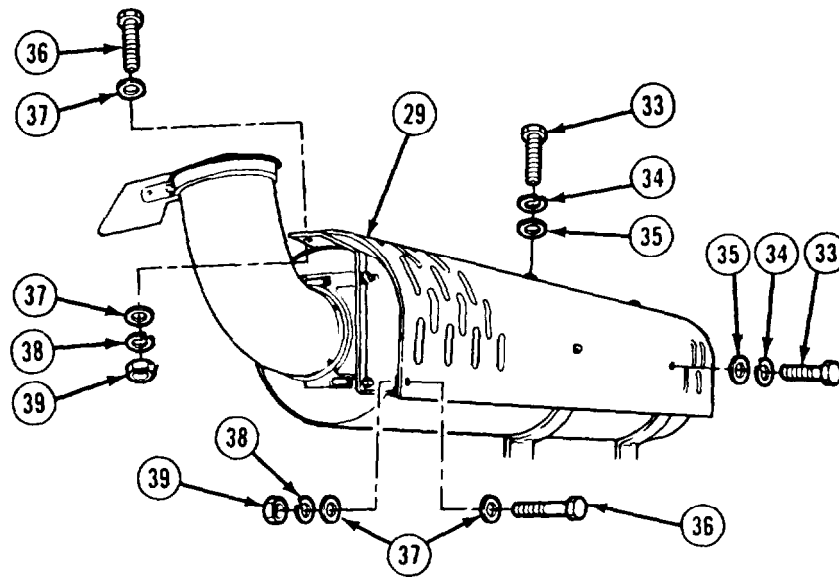
NOTE

Rain cap must open toward rear of vehicle.

- (12) Install rain cap (26), tightening nut (27).
- (13) Install muffler guard end (28) on muffler guard (29) with two screws (30), lockwashers (31), and nuts (32).



Exhaust System Maintenance Instructions (Cont)



- (14) Install muffler guard (29) and attach to muffler strap clamps (1) with four screws (33), lockwashers (34), and washers (35).
- (15) Install two screws (36), four washers (37), two lockwashers (38), and nuts (39).
- (16) Tighten nuts (21 and 25).

c. **Follow-on Maintenance.** Close engine cover (TM 9-2320-279-10).

END OF TASK

CHAPTER 6 COOLING SYSTEM MAINTENANCE

| Contents | Para | Page |
|---|-------------|-------------|
| General | 6-1 | 6-1 |
| Cooling System Servicing | 6-2 | 6-2 |
| Radiator Removal/Installation | 6-3 | 6-5 |
| Radiator Baffle Removal/Installation | 6-4 | 6-9 |
| Side and Bottom Radiator Baffle Removal/Installation | 6-5 | 6-12 |
| Fan Shroud Removal/Installation | 6-6 | 6-16 |
| Cooling System Hoses and Tubes | 6-7 | 6-17 |
| Left Thermostat, Cover, and Housing Removal/Installation | 6-8 | 6-23 |
| Right Thermostat, Cover, and Housing Removal/Installation | 6-9 | 6-28 |
| Fan Control Valve Removal/Installation | 6-10 | 6-36 |
| Fan Removal/Installation | 6-11 | 6-38 |
| Fan Clutch Removal/Installation | 6-12 | 6-42 |
| Fan Clutch to Engine Block Hose Removal/Installation | 6-13 | 6-44 |
| Alternator Belt Adjustment | 6-14 | 6-46.1 |
| Alternator Belt Removal/Installation | 6-15 | 6-48 |
| Fan Belt Adjustment | 6-16 | 6-49 |
| Fan Belt Removal/Installation | 6-17 | 6-50 |

Section I. INTRODUCTION

6-1. GENERAL. This chapter contains maintenance instructions for removing, adjusting, servicing, replacing, and installing the cooling system components authorized by the Maintenance Allocation Chart (MAC) at the organizational maintenance level.

Section II. RADIATOR

Cooling System Maintenance Instructions

6-2. COOLING SYSTEM SERVICING.

This task covers:

- a. Drain Cooling System
- b. Fill Cooling System
- c. Follow-on Maintenance

INITIAL SETUP

Models

All

Test Equipment

None

Special Tools

None

Supplies

Antifreeze, permanent, Item 5, Appendix C
 Antifreeze, arctic type, Item 6, Appendix C
 Inhibitor, corrosion, Item 23.5, Appendix C

Personnel Required

MOS 63S, Heavy wheel vehicle mechanic

References

TB 750-651

Equipment Condition

| <i>TM or Para</i> | <i>Condition Description</i> |
|-------------------|------------------------------|
| TM 9-2320-279-10 | Shut off engine. |
| TM 9-2320-279-10 | Engine cover open. |
| TM 9-2320-279-10 | Engine side panels removed. |

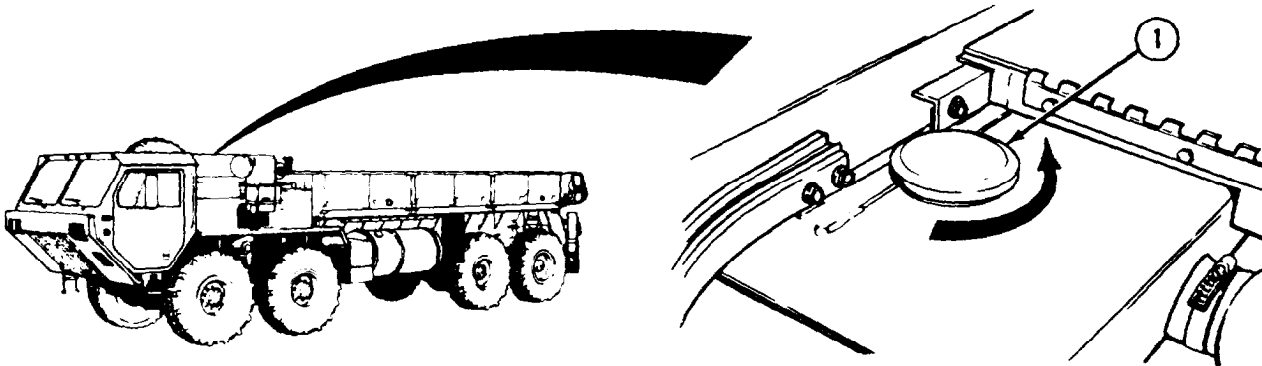
Special Environmental Conditions

None

General Safety Instructions

None

a. Drain Cooling System.

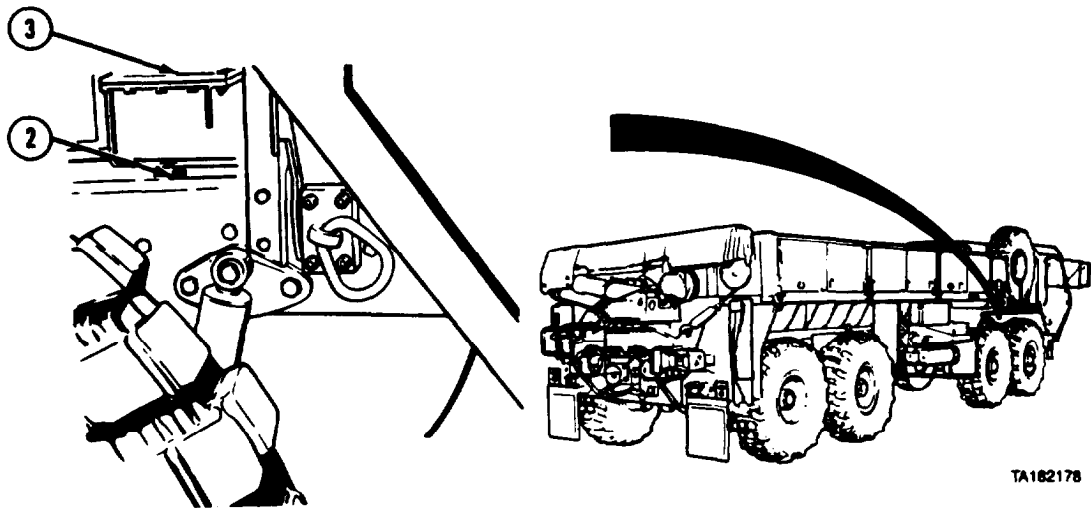


WARNING

Radiator cap may be very hot after engine is shut off. Do not touch hot cap or personal injury may result.

- (1) Turn radiator cap (1) counterclockwise, slowly, to allow pressure to escape.
- (2) Remove radiator cap (1) after pressure escapes.

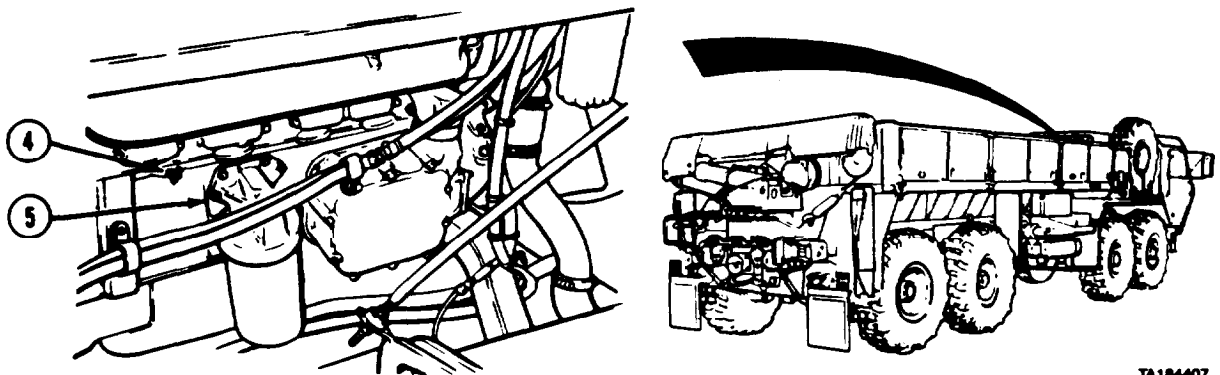
Cooling System Maintenance Instructions (Cont)



NOTE

- When draining radiator, place suitable container directly under draincock to prevent antifreeze from draining on vehicle and ground.
- Drain radiator only until antifreeze is below upper radiator hose.

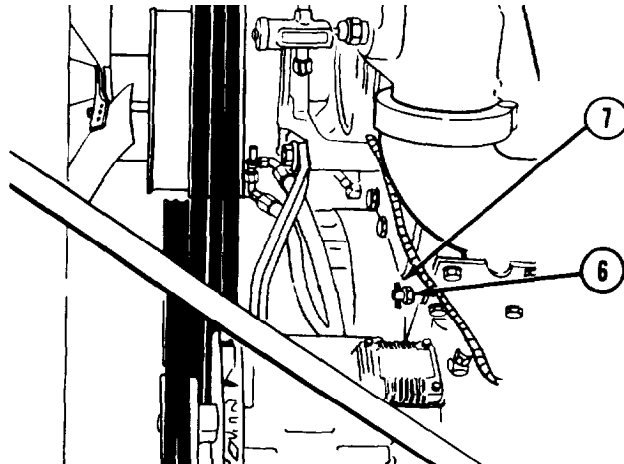
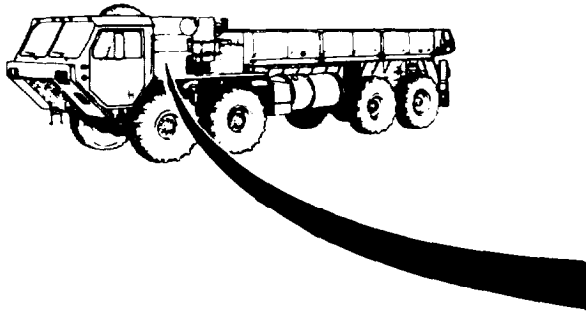
- (3) Turn draincock (2) to open and drain antifreeze from radiator (3).
- (4) Turn draincock (2) to close when radiator (3) is empty, or when antifreeze is at appropriate level.



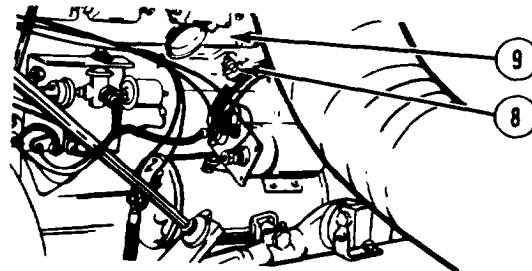
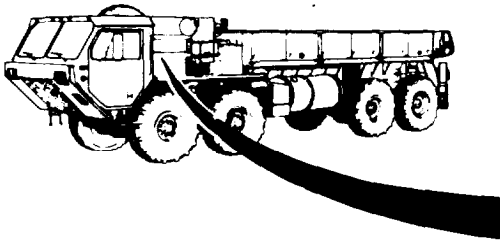
- (5) Turn draincock (4) to open and drain antifreeze.
- (6) Turn draincock (4) to close when right side cooling system (5) is drained.

Cooling System Maintenance Instructions (Cont)

6-2. COOLING SYSTEM SERVICING (CONT).



- (7) Turn draincock (6) to open and drain antifreeze.
- (8) Turn draincock (6) to close when front cooling system (7) is drained.



- (9) Turn draincock (8) to open and drain antifreeze.
- (10) Turn draincock (8) to close when left side cooling system (9) is drained.

b. Fill Cooling System.

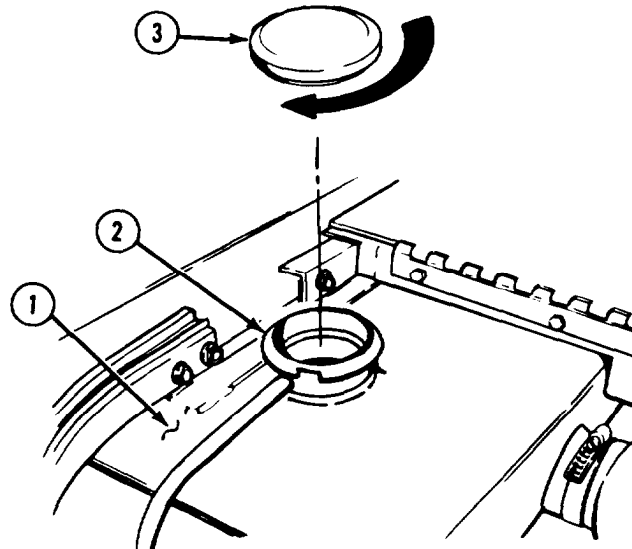
NOTE

Make sure radiator draincock and cooling system draincocks are closed before filling radiator with antifreeze.

- (1) Fill radiator (1) with 2.4 qt (228 L) corrosion inhibitor and up to within 1 in. below filler neck (2) with permanent antifreeze.
- (2) Install radiator cap (3) by turning radiator cap clockwise.

c. Follow-on Maintenance.

- (1) Start engine and warm up to normal operating temperature (TM 9-2320-279-10).
- (2) Check cooling system for leaks.
- (3) Shut off engine (TM 9-2320-279-10).
- (4) Install engine side panels (TM 9-2320-279-10).
- (5) Close engine cover (TM 9-2320-279-10).



END OF TASK

Cooling System Maintenance Instructions (Cont)

| | |
|---|--|
| 6-3. RADIATOR REMOVAL/INSTALLATION. | |
| This task covers: | |
| a. Removal b. Installation | c. Follow-on Maintenance |
| INITIAL SETUP | |
| <i>Models</i> All | <i>Equipment Condition</i> |
| <i>Test Equipment</i> None | <i>TM or Para</i> <i>Condition Description</i> |
| <i>Special Tools</i> None | TM 9-2320-279-10 Shut off engine. |
| <i>Supplies</i> Compound, sealing, pipe thread, Item 18, Appendix C Tags, identification, Item 48, Appendix C | Para 6-2 Cooling system drained. |
| | Para 6-6 Fan shroud removed. |
| | Para 6-7 Cooling system hoses and tubes removed. |
| | Para 6-5 Radiator baffle removed. |
| | Para 6-11 Fan removed. |
| <i>Personnel Required</i> MOS 63S, Heavy wheel vehicle mechanic (4) | <i>Special Environmental Conditions</i> None |
| <i>References</i> None | <i>General Safety Instructions</i> None |

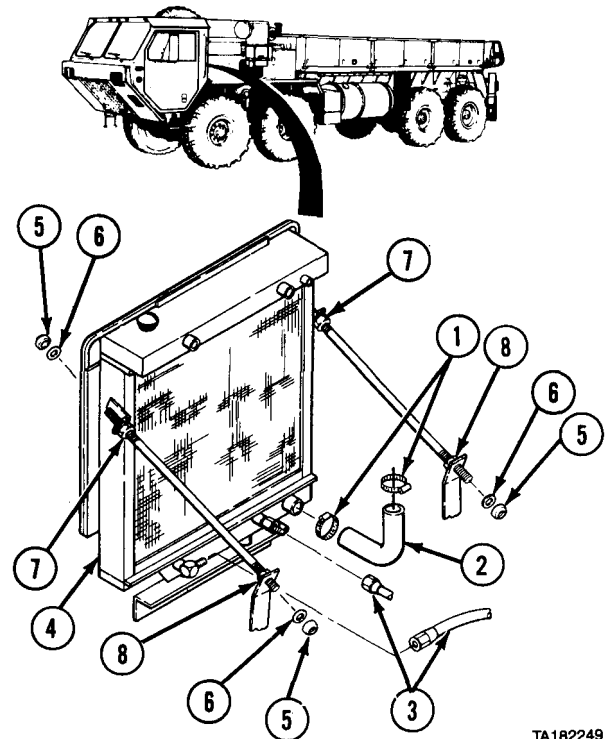
a. Removal.

- (1) Loosen two hose clamps (1).
- (2) Remove lower radiator hose (2).

NOTE

Tag and mark hoses before removing.

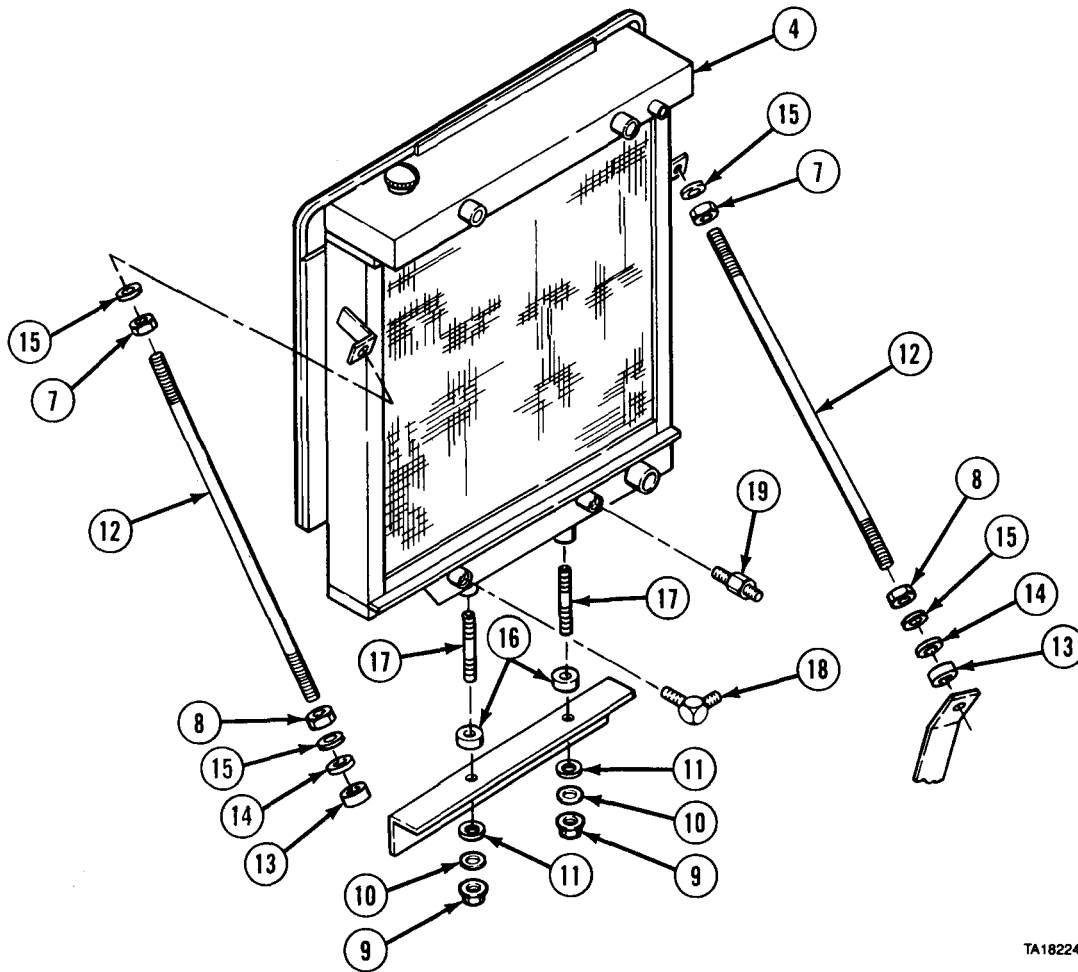
- (3) Remove left and right automatic transmission hoses (3).
- (4) Support radiator (4) with suitable lifting device.
- (5) Remove four nuts (5) and washers (6).
- (6) Thread two upper nuts (7) all the way down and two lower nuts (8) all the way up.



TA182249

Cooling System Maintenance Instructions (Cont)

6-3. RADIATOR REMOVAL/INSTALLATION (CONT).



TA182247

- (7) Remove two nuts (9), washers (10), and spacers (11).
- (8) Soldier A, Soldier B, and Soldier C guide radiator (4) and rods (12).
- (9) Soldier D lift radiator (4) with suitable lifting device.
- (10) Soldier A and Soldier B remove two rods (12), mounts (13), spacers (14), four washers (15), and nuts (7 and 8).

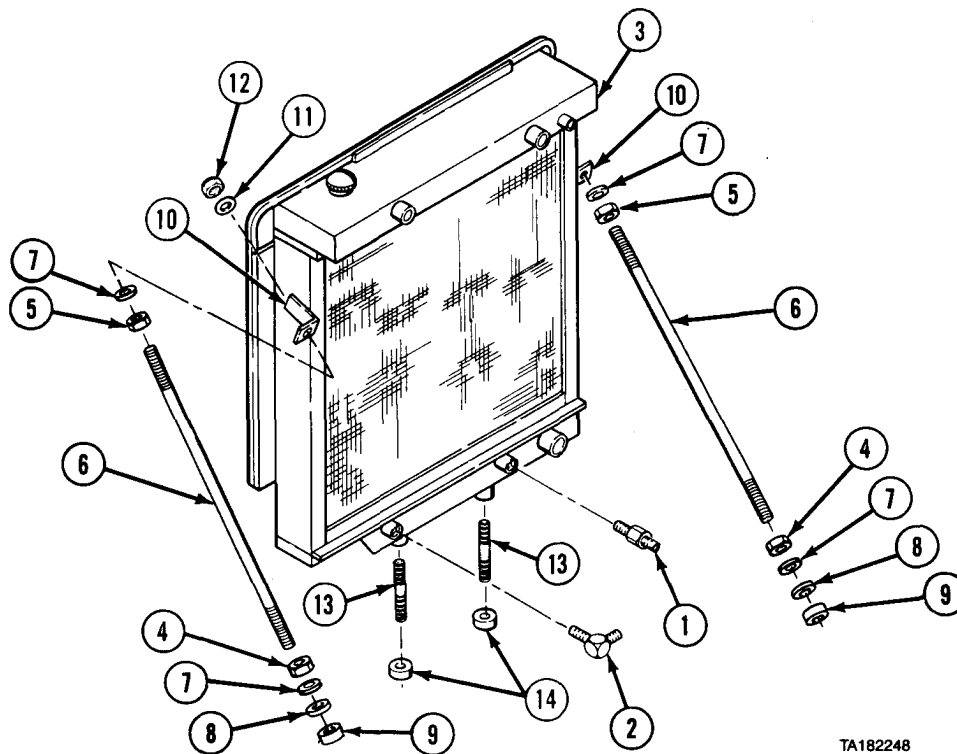
CAUTION

Do not grip on studs closer than 1-1/2 in. (38 mm) from each end of studs. Studs will be damaged.

- (11) Remove mounts (16) and studs (17).
- (12) Remove elbow fitting (18) and straight fitting (19).

Cooling System Maintenance Instructions (Cont)

b. Installation.



TA182248

WARNING

Adhesives, solvents, and sealing compounds can burn easily, can give off harmful vapors, and are harmful to skin and clothing. To avoid injury or death, keep away from open fire and use in well-ventilated area. If adhesive, solvent, or sealing compound gets on skin or clothing, wash immediately with soap and water.

- (1) Coat pipe threads of fittings (1 and 2) with pipe thread sealing compound and install in radiator (3).
- (2) Install four nuts (4 and 5) all the way on rods (6) with four washers (7), two spacers (8), and mounts (9). Install rods in radiator brackets (10) with two washers (11) and nuts (12). Do not tighten nuts.

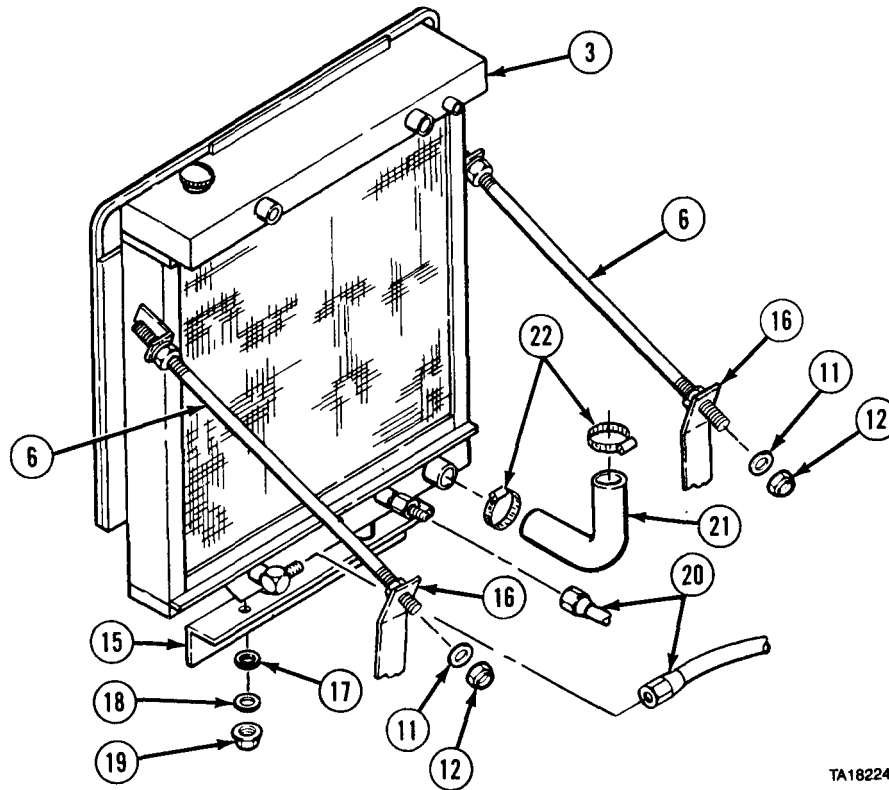
CAUTION

Do not grip studs closer than 1-1/2 in. (38 mm) from each end of stud. Studs will be damaged.

- (3) Install two studs (13) in radiator (3).
- (4) Install two mounts (14) on studs (13).

Cooling System Maintenance Instructions (Cont)

6-3. RADIATOR REMOVAL/INSTALLATION (CONT).



TA182244

- (5) Soldier A, Soldier B, and Soldier C guide radiator (3) into place over crossmember (15) and guide rods (6) into two brackets (16).
- (6) Soldier D lowers radiator (3) into place with suitable lifting device.
- (7) Soldier A installs two spacers (17), washers (18), and nuts (19).
- (8) Soldier B and Soldier C install two washers (11) and nuts (12).
- (9) Install two transmission oil hoses (20).
- (10) Install lower radiator hose (21) and tighten two clamps (22).

c. Follow-on Maintenance.

- (1) Install fan shroud (para 6-6).
- (2) Install fan (para 6-11).
- (3) Install cooling system hoses and tubes (para 6-7).
- (4) Install radiator baffle (para 6-5).
- (5) Fill cooling system (para 6-2).
- (6) Check transmission oil level (TM 9-2320-279-10).

END OF TASK

Cooling System Maintenance Instructions (Cont)

6-4. RADIATOR BAFFLE REMOVAL/INSTALLATION.

This task covers:

- a. Removal
- b. Installation
- c. Follow-on Maintenance

INITIAL SETUP

Models

All

Test Equipment

None

Special Tools

None

Supplies

None

Personnel Required

MOS 63S, Heavy wheel vehicle mechanic

References

None

Equipment Condition

TM or Para

Condition Description

- TM 9-2320-279-10 Shut off engine.
- TM 9-2320-279-10 Engine cover open.
- TM 9-2320-279-10 Engine side panels removed.

Special Environmental Conditions

None

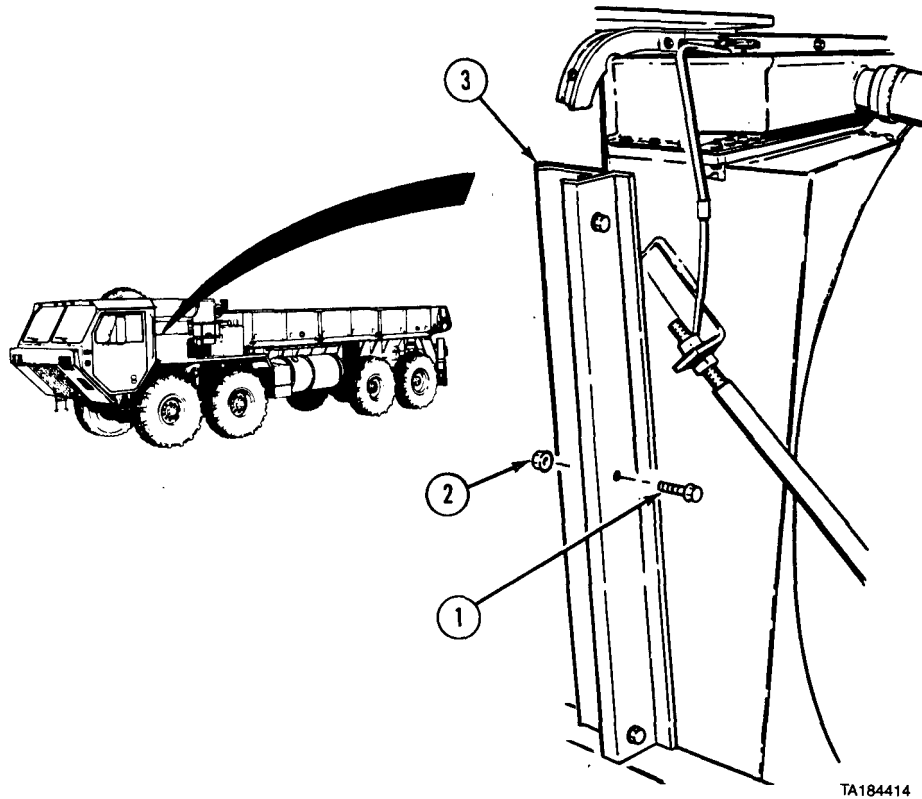
General Safety Instructions

None

Cooling System Maintenance Instructions (Cont)

6-4. RADIATOR BAFFLE REMOVAL/INSTALLATION (CONT).

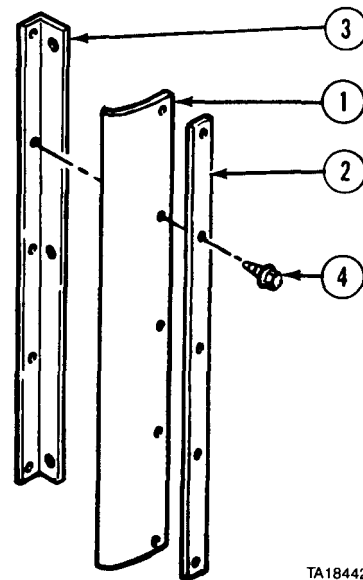
a. Removal.



NOTE

Left and right radiator baffles are removed the same way.

- (1) Remove three screws (1) and locknuts (2).
- (2) Remove radiator baffle (3).
- (3) Remove five screws (4), retaining plate (5), and rubber strip (6) from baffle bracket (7).



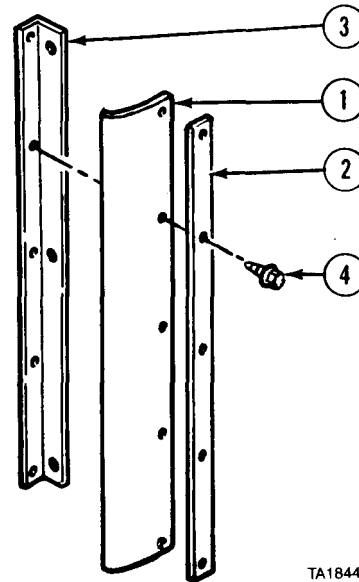
Cooling System Maintenance Instructions (Cont)

b. Installation.

NOTE

Left and right radiator baffles are installed the same way.

- (1) Install rubber strip (1) and retaining plate (2) to baffle bracket (3) with five screws (4).



TA184420

NOTE

Baffles must turn outward.

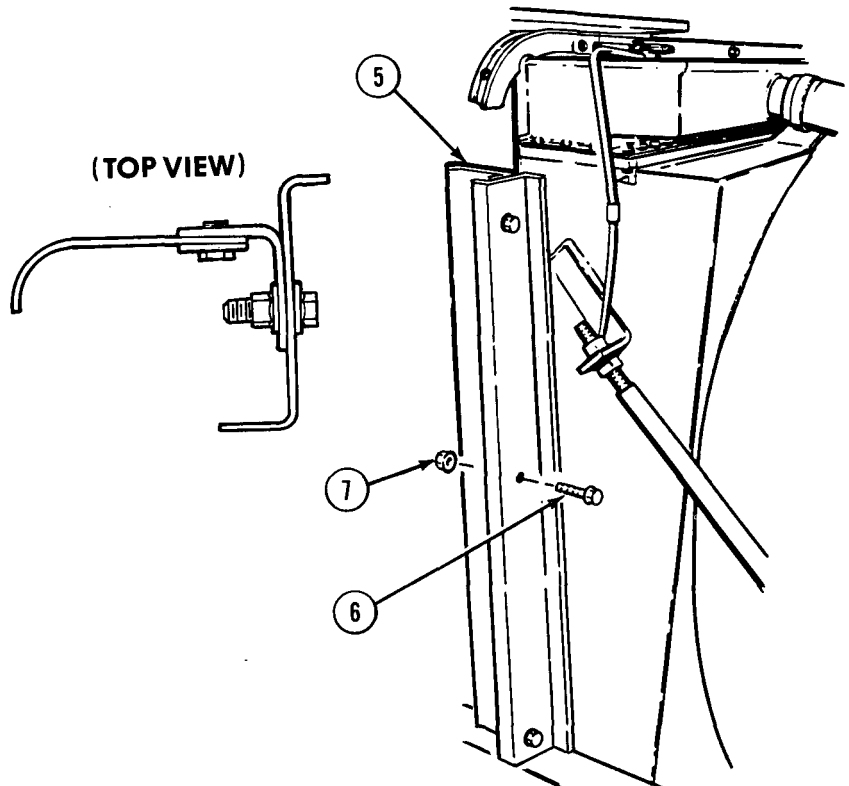
- (2) Install radiator baffle (5) with three screws (6) and locknuts (7).

c. Follow-on Maintenance.

- (1) Install engine side panels (TM 9-2320-279-10).
- (2) Close engine cover (TM 9-2320-279-10).

END OF TASK

(TOP VIEW)



TA184415

Cooling System Maintenance Instructions (Cont)

6-5. SIDE AND BOTTOM RADIATOR BAFFLE REMOVAL/INSTALLATION.

This task covers:

- a. Removal
- b. Installation
- c. Follow-on Maintenance

INITIAL SETUP

Models

All

Test Equipment

None

Special Tools

None

Supplies

Ties, cable, plastic, Item 52, Appendix C

Personnel Required

MOS 63S, Heavy wheel vehicle mechanic

References

None

Equipment Condition

TM or Para *Condition Description*
 TM 9-2320-279-10 Shut off engine.

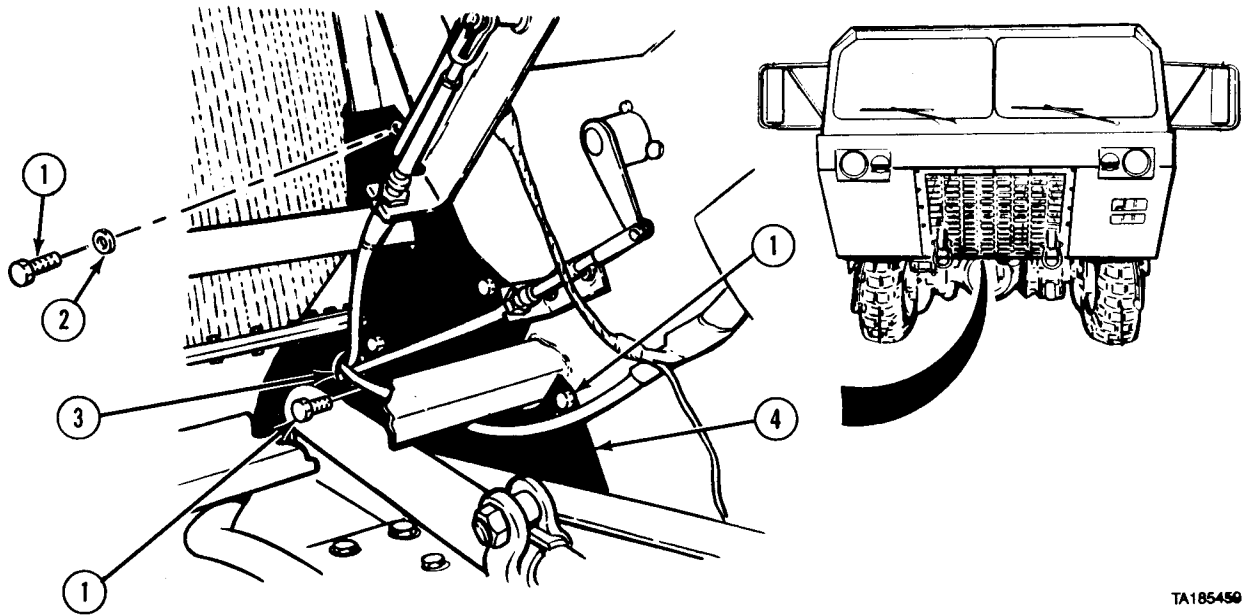
Special Environmental Conditions

None

General Safety Instructions

None

a. Removal.



TA185450

NOTE

Right and left side baffles are removed the same way except right side baffle does not have cushion clip.

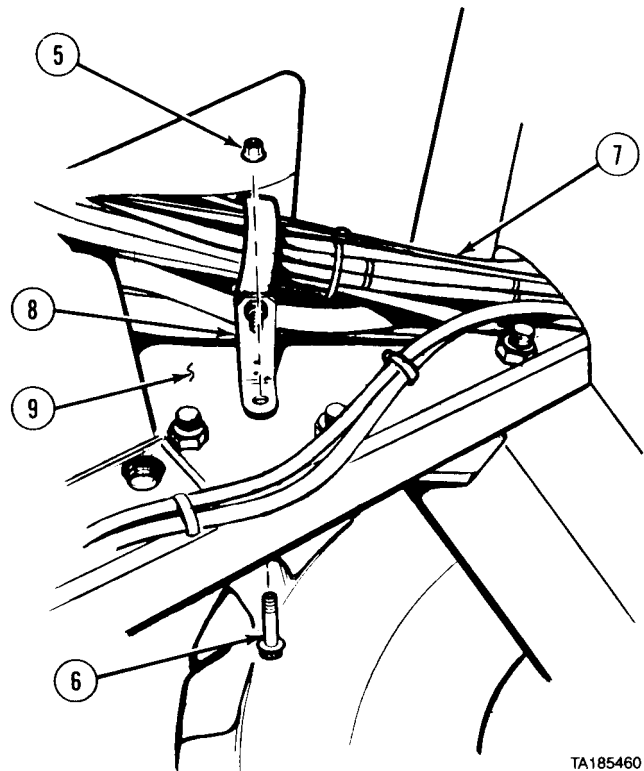
- (1) Remove six screws (1), four washers (2), and cushion clip (3).
- (2) Remove baffle (4).

Cooling System Maintenance Instructions (Cont)

NOTE

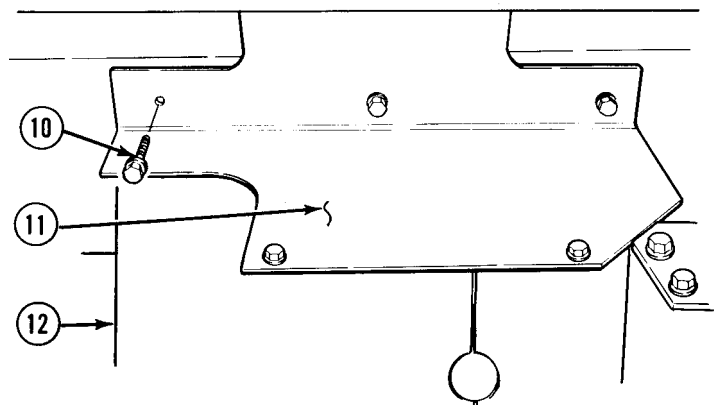
Cut and remove plastic cable ties as needed.

- (3) Remove nut (5) and screw (6). Move harness (7) and bracket (8) up toward frame (9).



TA185460

- (4) Remove five screws (10), bottom radiator baffle (11), and baffle (12).



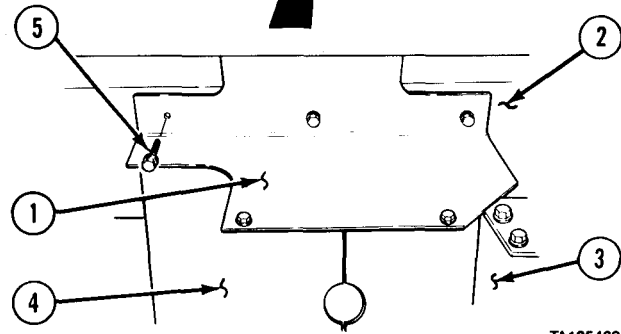
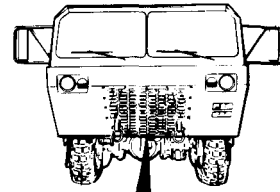
TA185461

Cooling System Maintenance Instructions (Cont)

6-5. SIDE AND BOTTOM RADIATOR BAFFLE REMOVAL/INSTALLATION (CONT).

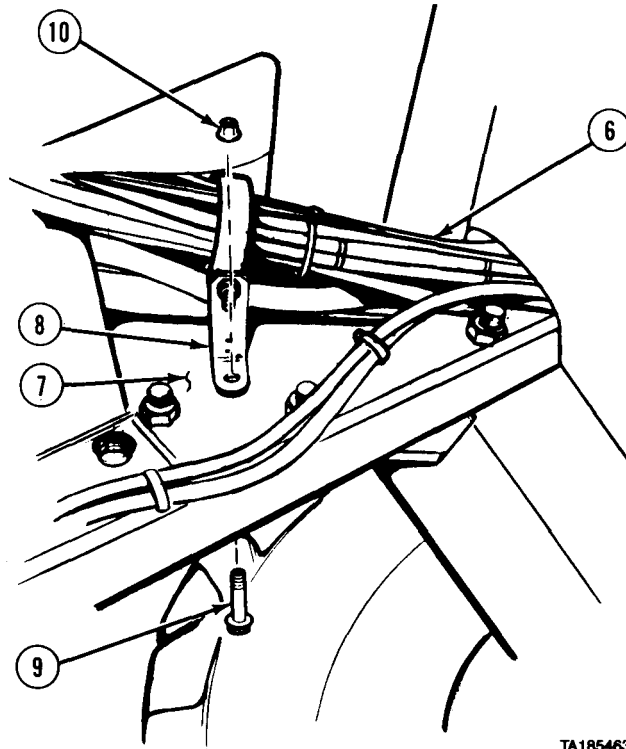
b. Installation.

- (1) Position bottom radiator baffle (1) on radiator mount (2) and frame crossmember (3).
- (2) Position baffle (4) between radiator mount (2) and bottom radiator baffle (1).
- (3) Install baffle (4) and bottom radiator baffle (1) with five screws (5).



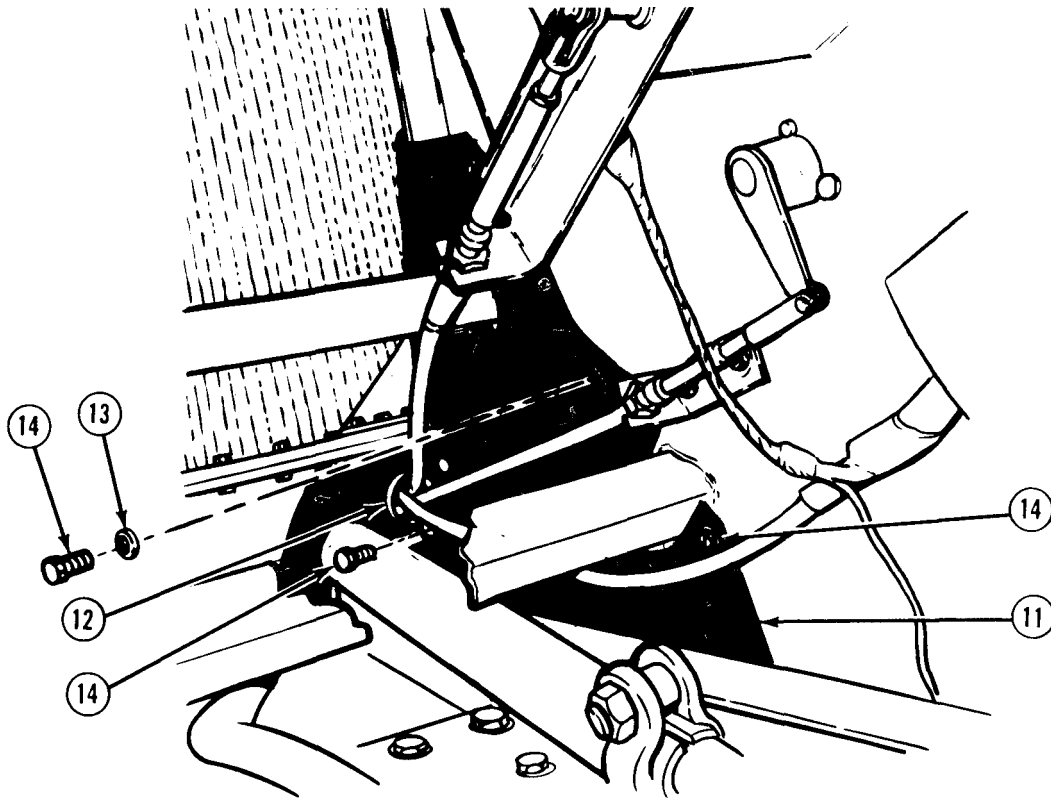
TA185482

- (4) Move harness (6) away from frame (7) and install bracket (8) with screw (9) and nut (10).



TA185463

Cooling System Maintenance Instructions (Cont)



TA185464

NOTE

Right and left side baffles are installed the same way except right side baffle does not have cushion clip.

(5) Install baffle (11) and cushion clip (12) with four washers (13) and six screws (14).

c. *Follow-on Maintenance.* None.

END OF TASK



Cooling System Maintenance Instructions (Cont)

6-6. FAN SHROUD REMOVAL/INSTALLATION.

This task covers:

- a. Removal
- b. Installation
- c. Follow-on Maintenance

INITIAL SETUP

Models

All

Test Equipment

None

Special Tools

None

Supplies

None

Personnel Required

MOS 63S, Heavy wheel vehicle mechanic (2)

References

None

Equipment Condition

| <i>TM or Para</i> | <i>Condition Description</i> |
|-------------------|------------------------------|
| TM 9-2320-279-10 | Shut off engine. |
| Para 6-11 | Fan removed. |

Special Environmental Conditions

None

General Safety Instructions

None

a. Removal.

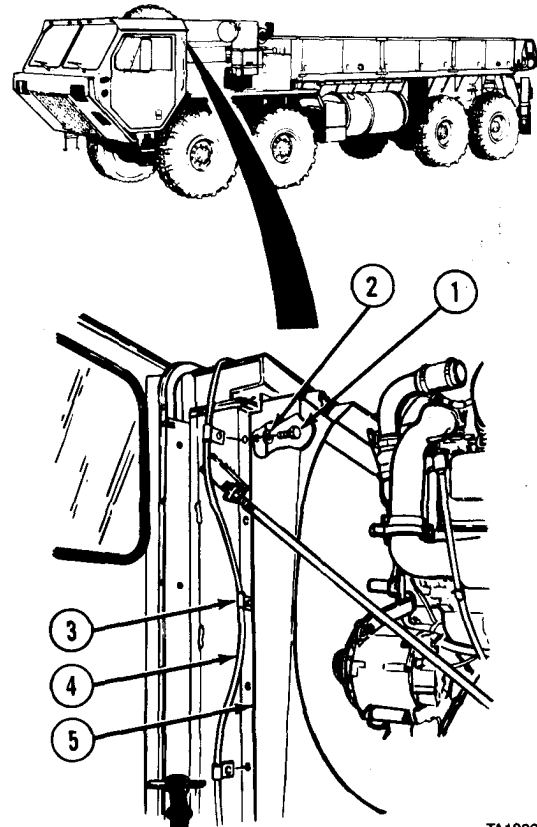
- (1) Remove 10 screws (1) and lockwashers (2).
- (2) Remove three tube clamps (3) from tube (4).
- (3) Soldier A and Soldier B remove fan shroud (5).

b. Installation.

- (1) Soldier A and Soldier B lift shroud (5) into place.
- (2) Install 10 screws (1), lockwashers (2), and three tube clamps (3).
- (3) Install tube (4) in tube clamps (3).

c. Follow-on Maintenance. Install fan (para 6-11).

END OF TASK



TA182213

Cooling System Maintenance Instructions (Cont)

6-7. COOLING SYSTEM HOSES AND TUBES REMOVAL/INSTALLATION.

This task covers:

- a. Removal
- b. Installation

c. Follow-on Maintenance

INITIAL SETUP

Models
All

Test Equipment
None

Special Tools
None

Supplies
Compound, sealing, pipe thread, Item 18, Appendix C

Personnel Required
MOS 63S, Heavy wheel vehicle mechanic

References
None

Equipment Condition

| <i>TM or Para</i> | <i>Condition Description</i> |
|-------------------|-----------------------------------|
| Para 6-2 | Cooling system drained. |
| Para 16-13 | Right front splash guard removed. |
| TM 9-2320-279-10 | Engine side panels removed. |
| TM 9-2320-279-10 | Spare tire removed. |

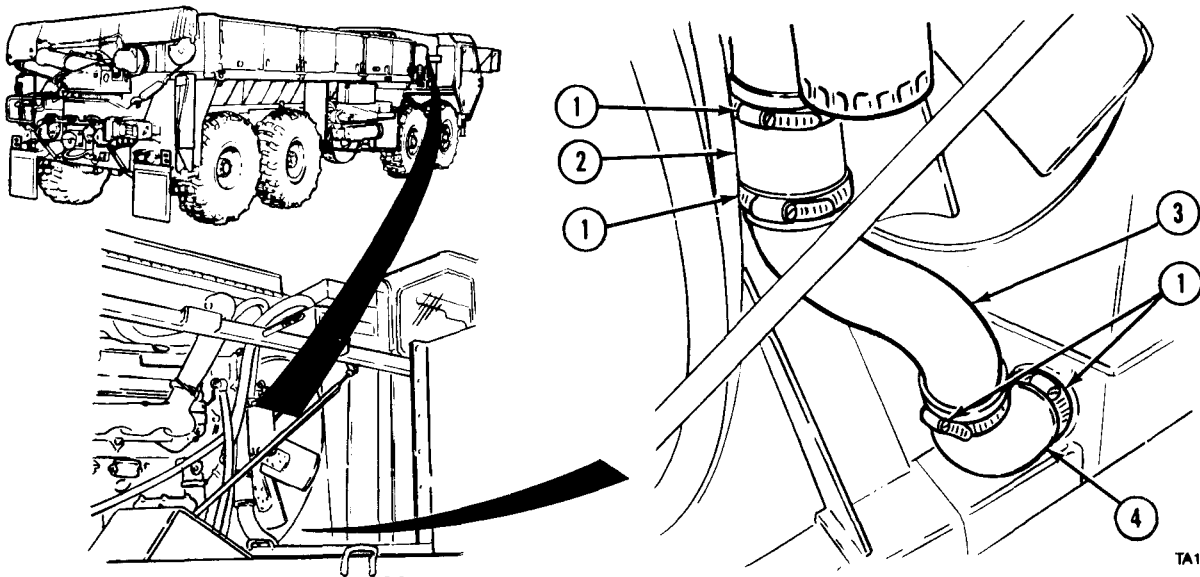
Special Environmental Conditions

None

General Safety Instructions

None

a. Removal.



TA182220

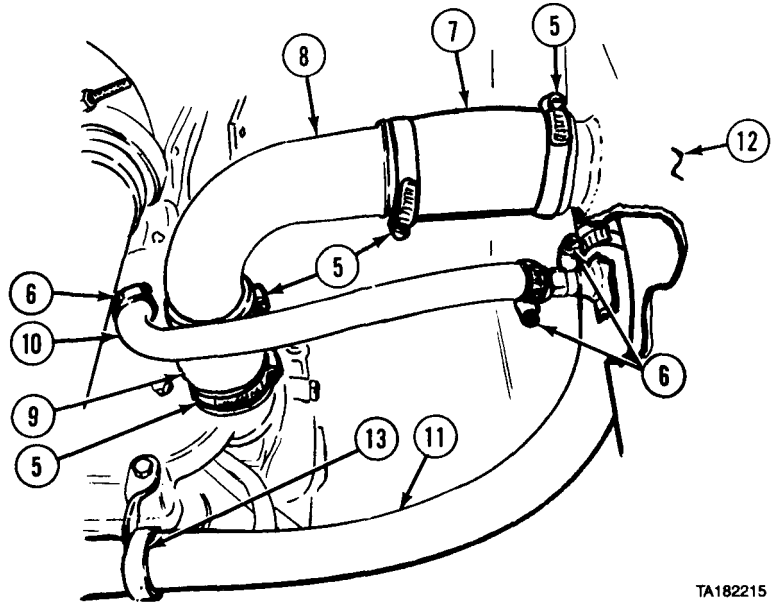
(1) Loosen four clamps (1).

(2) Disconnect and remove hose (2), tube (3), and rubber elbow (4).

Cooling System Maintenance Instructions (Cont)

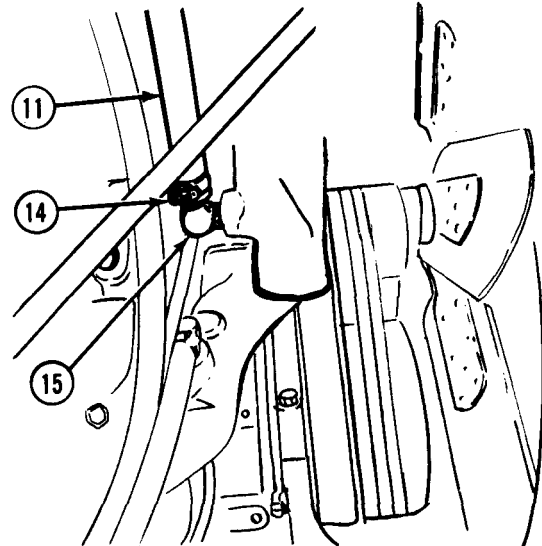
6-7. COOLING SYSTEM HOSES AND TUBES REMOVAL/INSTALLATION (CONT).

- (3) Loosen four clamps (5).
- (4) Loosen three clamps (6).
- (5) Remove hose (7), tube (8), hose (9), and hose (10).
- (6) Disconnect hose (11) from radiator (12).
- (7) Pull loose end of hose (11) through tubing clamp (13).



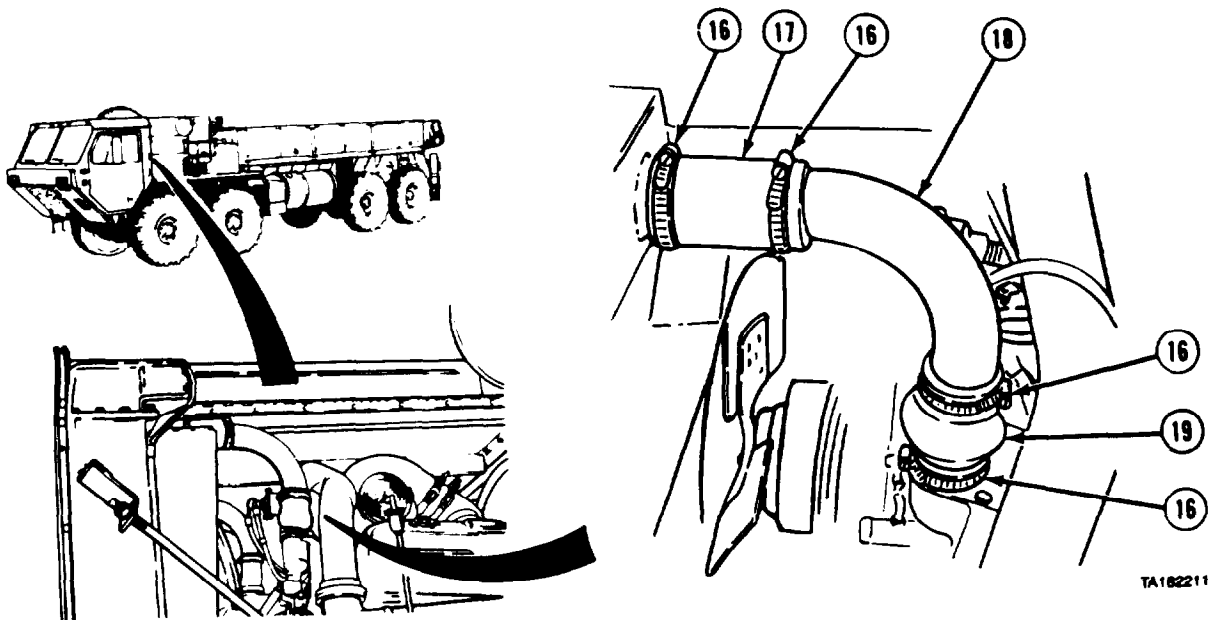
TA182215

- (8) Loosen clamp (14) and remove hose (11).
- (9) Remove fitting (15).



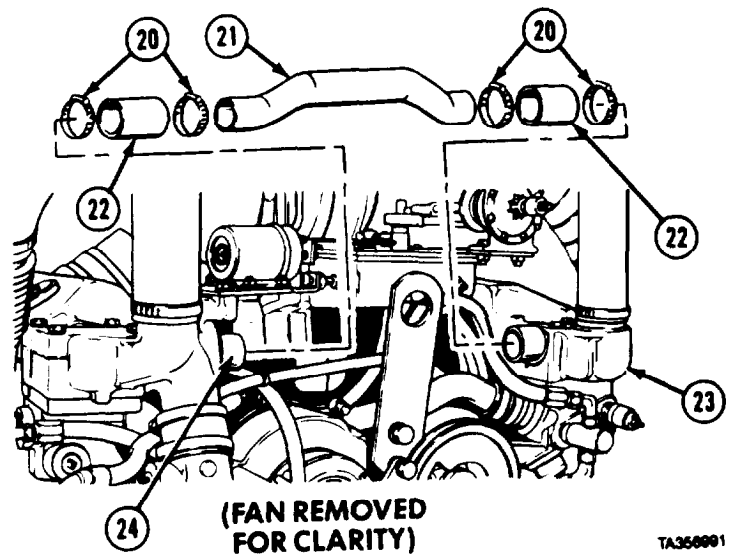
TA182217

Cooling System Maintenance Instructions (Cont)



- (10) Loosen four clamps (16).
- (11) Remove hose (17), tube (18), and hose (19).

- (12) Loosen four clamps (20).
- (13) Remove thermostat bypass tube (21), two hoses (22), and four clamps (20) from thermostat housing covers (23 and 24).



Cooling System Maintenance Instructions (Cont)

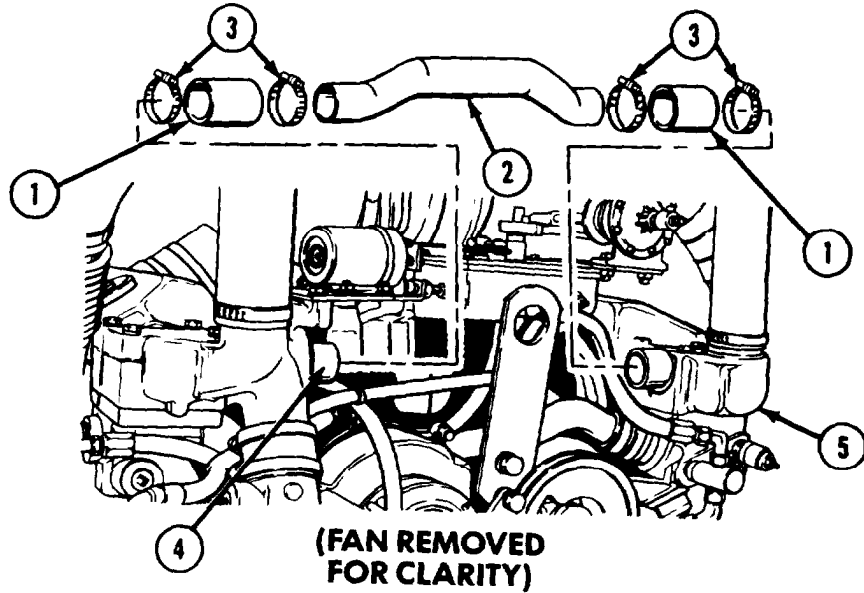
6-7. COOLING SYSTEM HOSES AND TUBES REMOVAL/INSTALLATION (CONT).

b. Installation.

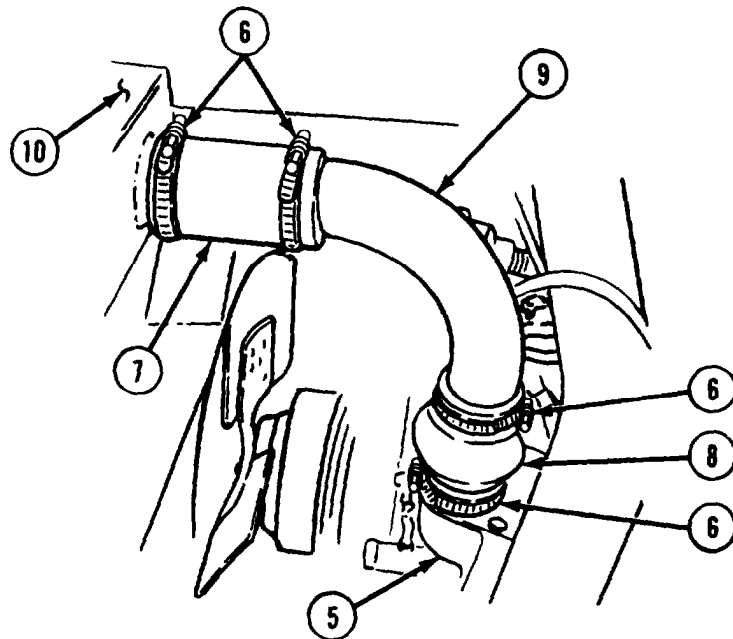
CAUTION

When replacing hose or hose clamps with new parts, hose and clamps must be replaced.

- (1) Install two hoses (1) and thermostat bypass tube (2) with four clamps (3) on thermostat housing covers (4 and 5). Tighten constant torque clamps to 40 in-lbs (4.5 N •m).



- (2) Install four clamps (6) loosely on hose (7) and hose (8).
- (3) Install hose (7) and hose (8) on tube (9).
- (4) Push hose (7) onto radiator (10) and hose (8) onto thermostat housing cover (5).
- (5) Tighten four clamps (6). Tighten constant torque clamps to 40 in-lbs. (4.5 N •m).

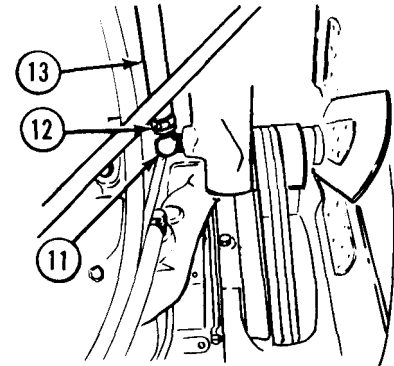


Cooling System Maintenance Instructions (Cont)

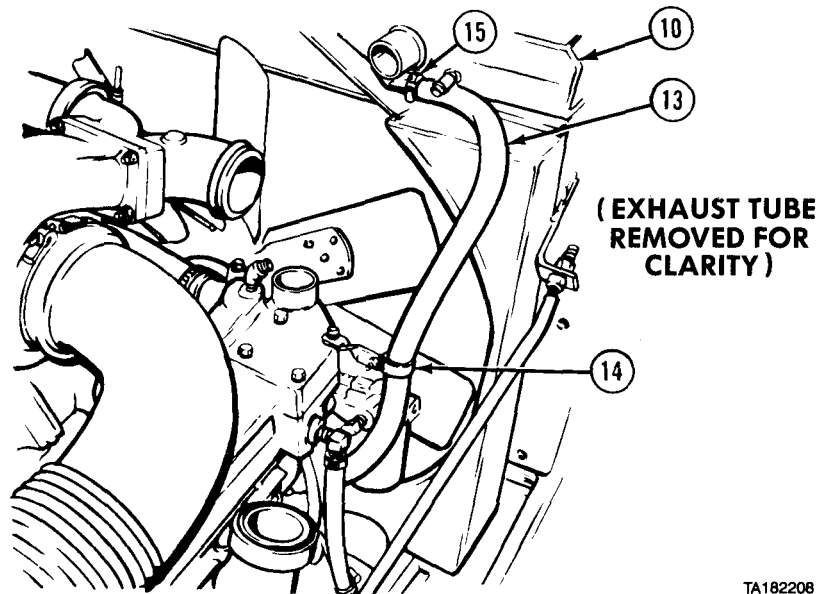
WARNING

Adhesives, solvents, and sealing compounds can burn easily, can give off harmful vapors, and are harmful to skin and clothing. To avoid injury or death, keep away from open fire and use in well-ventilated area. If adhesive, solvent, or sealing compound gets on skin or clothing, wash immediately with soap and water.

- (6) Apply pipe thread sealing compound to fitting (11) and install.
- (7) Loosely install clamp (12) on hose (13).
- (8) Push hose onto fitting (11) and tighten clamp (12).
- (9) Push free end of hose (13) through tubing clamp (14).
- (10) Loosely install clamp (15) on hose (13) and push hose onto tube on radiator (10). Tighten clamp.



TA182218

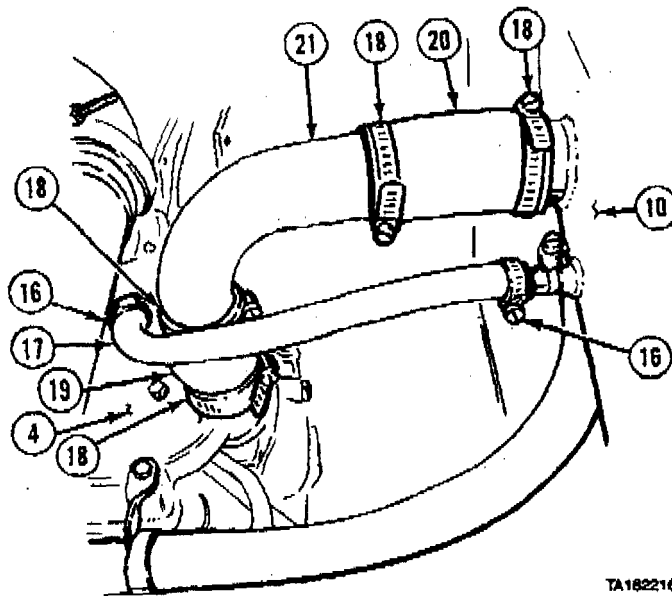


TA182208

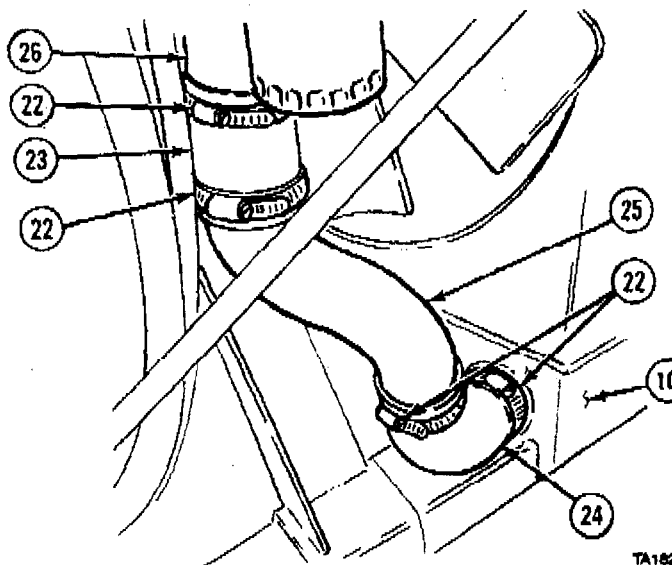
Cooling System Maintenance Instructions (Cont)

6-7. COOLING SYSTEM HOSES AND TUBES REMOVAL/INSTALLATION (CONT).

- (11) Loosely install two clamps (16) on hose (17).
- (12) Install hose (17) on radiator (10) and on top of thermostat housing cover (4).
- (13) Tighten two Clamps (16).
- (14) Loosely install four clamps (18) on hose (19) and hose (20).
- (15) Install hose (19) and hose (20) on tube (21).
- (16) Push hose (19) onto tube (21) on thermostat housing cover (4) and hose (20) onto radiator (10).
- (17) Tighten four clamps (18).



- (18) Loosely install four clamps (22) on hose (23) and rubber elbow (24).
- (19) Install hose (23) and rubber elbow (24) on tube (25).
- (20) Install hose (23) on water pump (26) and rubber elbow (24) on radiator (10).
- (21) Tighten four clamps (22).



c. Follow-on Maintenance.

- (1) Fill cooling system (para 6-2).
- (2) Start and warm up engine, Check tubes and hoses for leaks (TM 9-2320-279-10).
- (3) Shut off engine (TM 9-2320-279-10).
- (4) Install right front splash guard (para 16-13).
- (5) Install engine side panels (TM 9-2320-279-10).
- (6) Install spare tire (TM 9-2320-279-10).

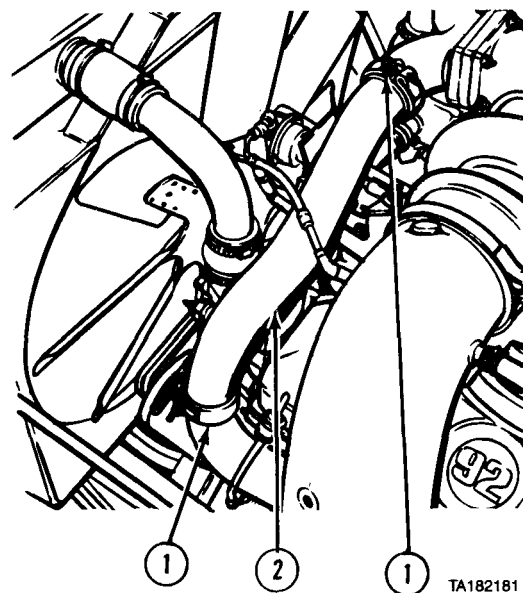
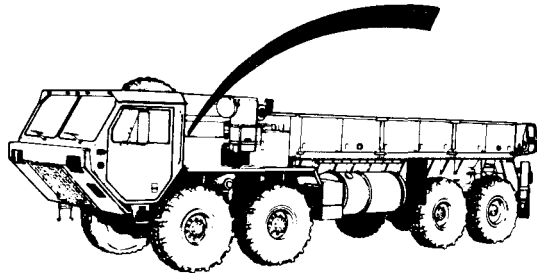
END OF TASK

Cooling System Maintenance Instructions (Cont)

Section III. THERMOSTATS

| | |
|--|--|
| 6-8. LEFT THERMOSTAT, COVER, AND HOUSING REMOVAL/INSTALLATION. | |
| This task covers: | |
| a. Removal | c. Follow-on Maintenance |
| b. Installation | |
| INITIAL SETUP | |
| Models | References |
| All | None |
| Test Equipment | Equipment Condition |
| None | <i>TM or Para</i> <i>Condition Description</i> |
| Special Tools | TM 9-2320-279-10 Shut off engine. |
| Handle, thermostat seal installer J7079-2 | Para 6-2 Cooling system drained. |
| Thermostat seal installer J8550 | Para 7-91 Batteries disconnected. |
| Supplies | Special Environmental Conditions |
| Adhesive-sealant, silicone, Item 4, Appendix C | None |
| Compound, sealing, pipe thread, Item 18, Appendix C | General Safety Instructions |
| Personnel Required | None |
| MOS 63S, Heavy wheel vehicle mechanic | |

a. Removal.

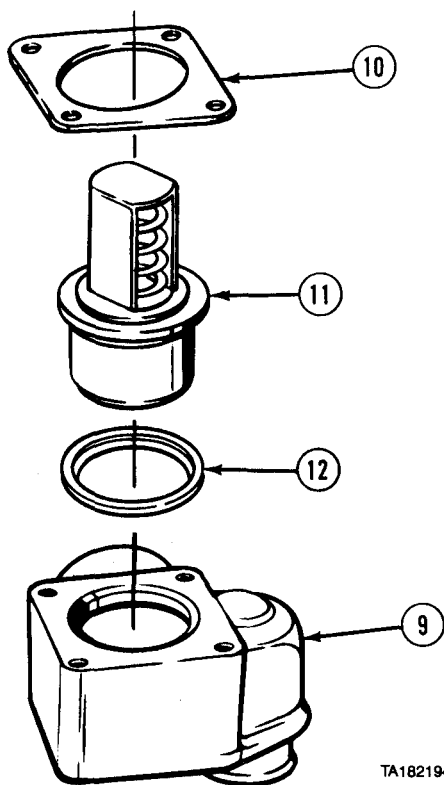
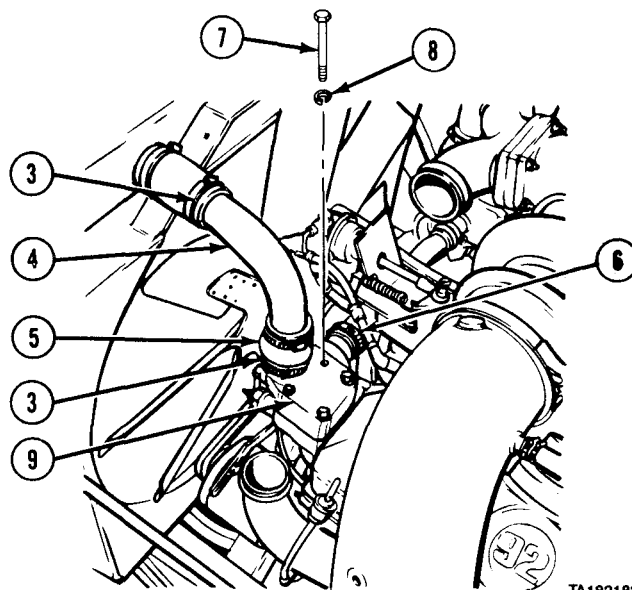


(1) Remove two clamps (1) and exhaust pipe (2).

Cooling System Maintenance Instructions (Cont)

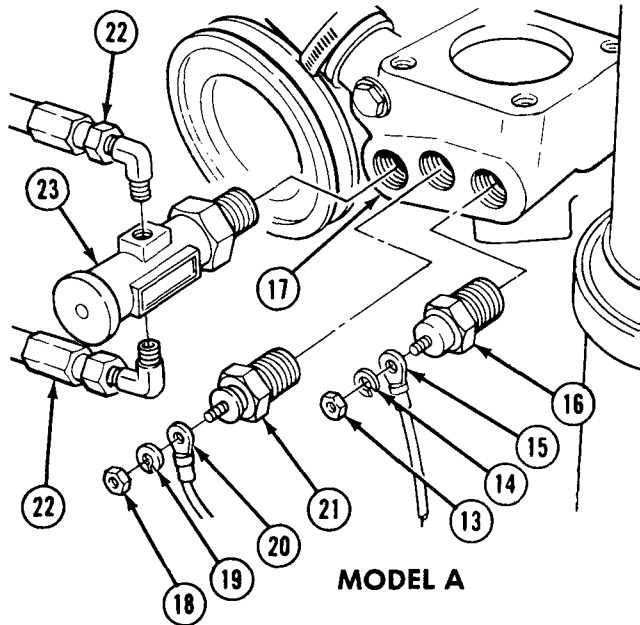
6-8. LEFT THERMOSTAT, COVER, AND HOUSING REMOVAL/INSTALLATION (CONT).

- (2) Loosen two clamps (3). Remove water tube (4) and hose (5).
- (3) Loosen clamp (6).
- (4) Remove four screws (7), lockwashers (8), and left thermostat housing cover (9).

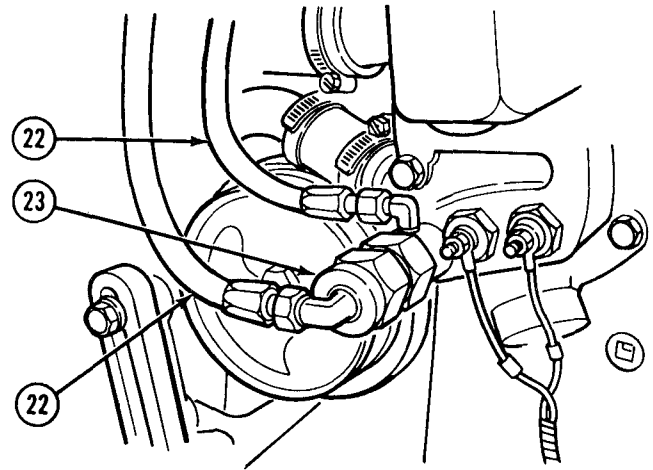


- (5) Turn thermostat housing cover (9) over.
- (6) Remove gasket (10) and pull thermostat (11) from thermostat housing cover (9).
- (7) Remove seal (12) from thermostat housing cover (9).

Cooling System Maintenance Instructions (Cont)



MODEL A



MODEL B

TA357010

- (8) Remove nut (13), lockwasher (14), wire (15), and alarmstat (16) from thermostat housing (17).
- (9) Remove nut (18), lockwasher (19), wire (20), and water temperature sending unit (21).

NOTE

Ž Vehicles may have old or new model fan control valves.

Ž Tag and mark air lines before removal.

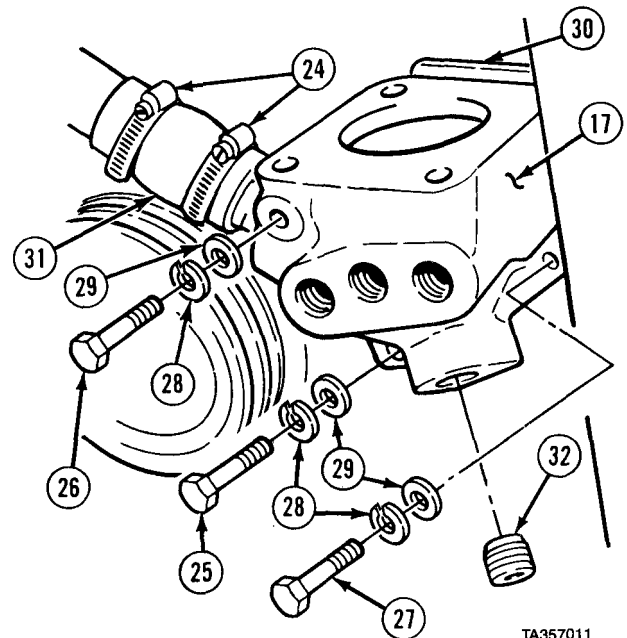
- (10) Remove two air lines (22) and fanstat (23).

- (11) Loosen two clamps (24).

- (12) Remove three screws (25, 26, and 27), lockwashers (28), and washer (29).

- (13) Remove thermostat housing (17), gasket (30), hose (31), and two clamps (24).

- (14) Remove plug (32).



TA357011

Cooling System Maintenance Instructions (Cont)

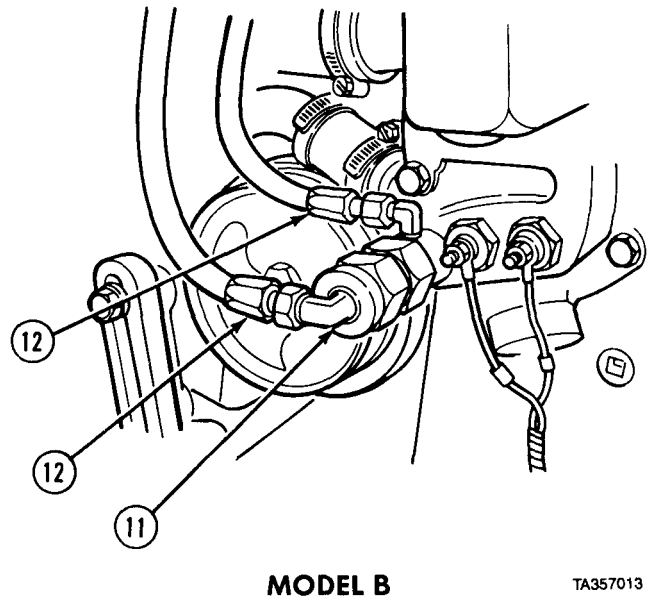
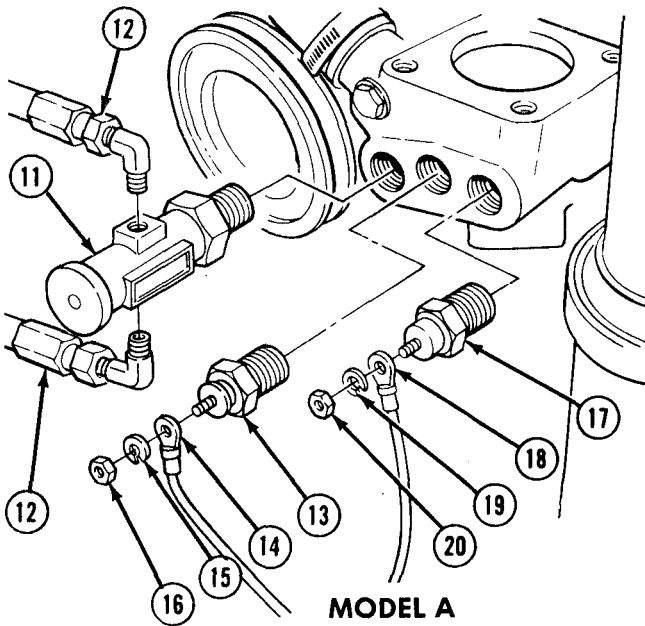
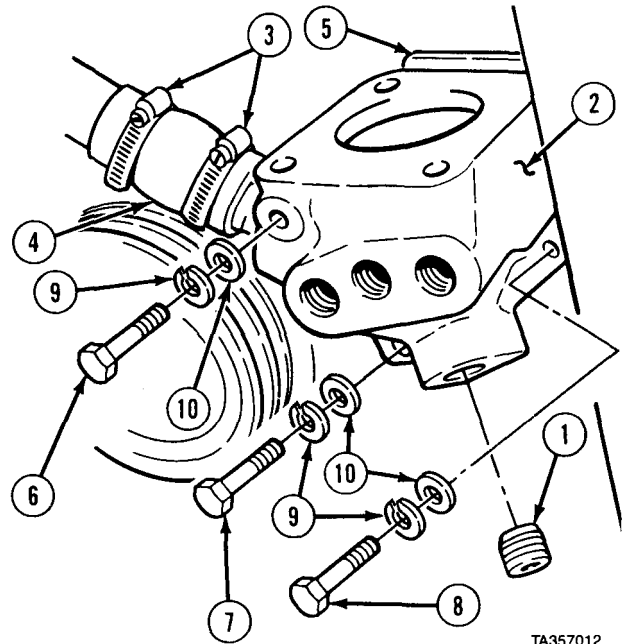
6-8. LEFT THERMOSTAT, COVER, AND HOUSING REMOVAL/INSTALLATION (CONT).

b. Installation.

WARNING

Adhesives, solvents, and sealing compounds can burn easily, can give off harmful vapors, and are harmful to skin and clothing. To avoid injury or death, keep away from open fire and use in well-ventilated area. If adhesive, solvent, or sealing compound gets on skin or clothing, wash immediately with soap and water.

- (1) Coat threads of plug (1) with pipe thread sealing compound and install in thermostat housing (2).
- (2) Install two clamps (3), hose (4), gasket (5), and thermostat housing (2).
- (3) Install three screws (6, 7, and 8), lockwasher (9), and washer (10).
- (4) Tighten two clamps (3).



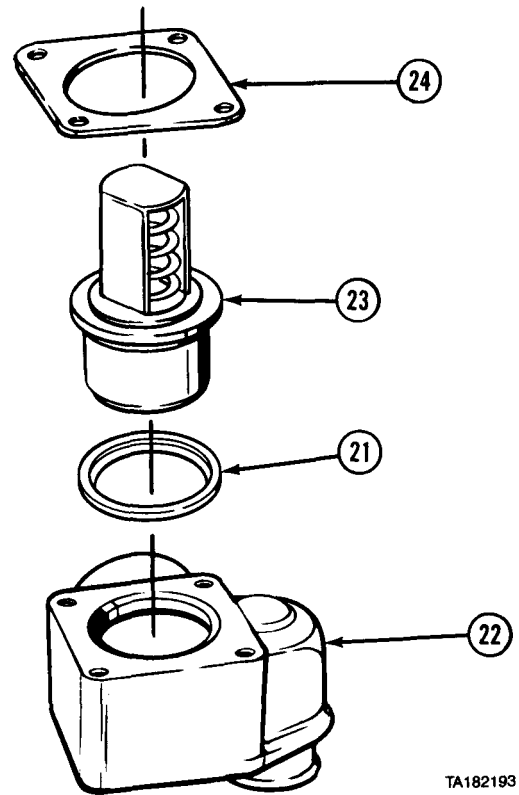
- (5) Coat threads of fanstat (11) with pipe thread sealing compound. Install fanstat and two air lines (12).
- (6) Coat threads of water temperature sending unit (13) with pipe thread sealing compound. Install water temperature sending unit, wire (14), lockwasher (15), and nut (16).
- (7) Coat threads of alarmstat (17) with pipe thread sealing compound. Install alarmstat, wire (18), lockwasher (19), and nut (20).

Cooling System Maintenance Instructions (Cont)

NOTE

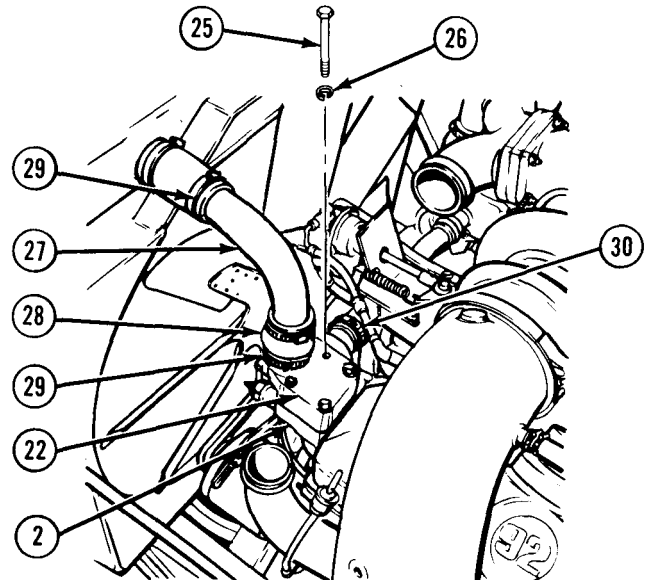
Lip on seal goes toward inside of thermostat housing cover.

- (8) Using thermostat seal installer and handle, install seal (21) into thermostat housing cover (22).
- (9) Install thermostat (23) in thermostat housing cover (22).
- (10) Coat gasket (24) with silicone adhesive-sealant and install on thermostat housing cover (22).



TA182193

- (11) Install thermostat housing cover (22) on thermostat housing (2) with four screws (25) and lockwashers (26). Tighten four screws to 23 to 26 lb-ft (31.2 to 35.3 N-m) using a cross-corner sequence.
- (12) Install water tube (27) and hose (28). Tighten two clamps (29).
- (13) Tighten clamp (30).



TA182195

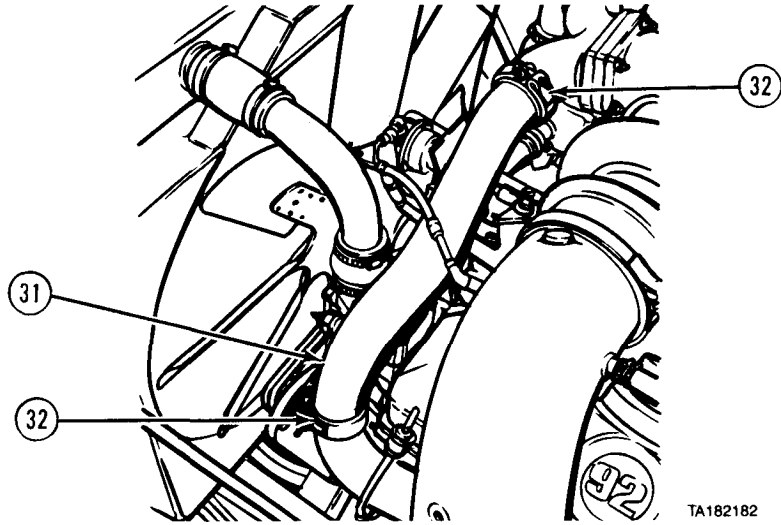
Cooling System Maintenance Instructions (Cont)

6-8. LEFT THERMOSTAT, COVER, AND HOUSING REMOVAL/INSTALLATION (CONT).

(14) Install exhaust pipe (31) with clamps (32).

c. Follow-on Maintenance.

- (1) Fill cooling system (para 6-2).
- (2) Connect batteries (para 7-91).
- (3) Start and warm up engine (TM 9-2320-279-10).
- (4) Check for leaks and operation of thermostat.
- (5) Shut off engine (TM 9-2320-279-10).



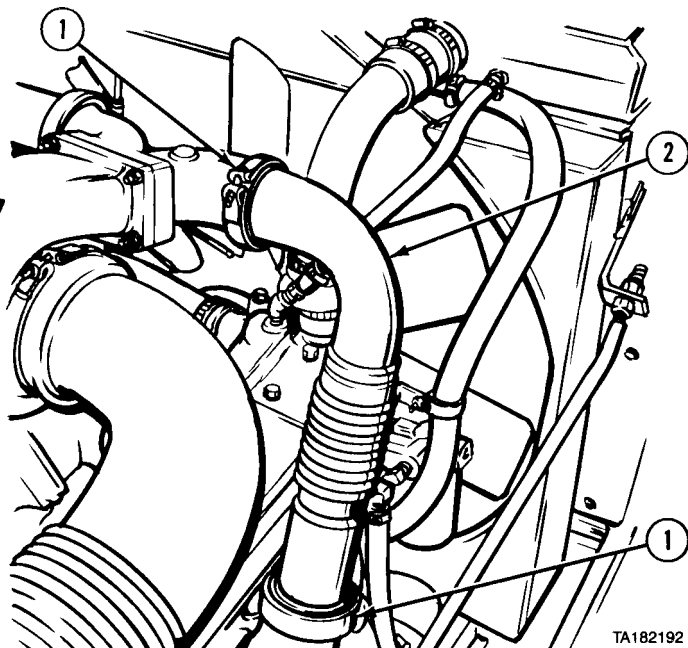
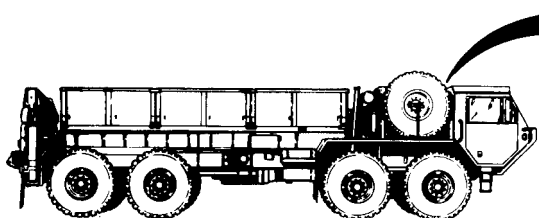
TA182182

END OF TASK

| 6-9. RIGHT THERMOSTAT, COVER, AND HOUSING REMOVAL/INSTALLATION. | | | | | | | | | |
|---|---|-------------------|------------------------------|------------------|------------------|----------|-------------------------|-----------|-------------------------|
| This task covers: | | | | | | | | | |
| <ul style="list-style-type: none"> a. Removal b. Installation | <ul style="list-style-type: none"> c. Follow-on Maintenance | | | | | | | | |
| INITIAL SETUP | | | | | | | | | |
| <p><i>Models</i> All</p> <p><i>Test Equipment</i> None</p> <p><i>Special Tools</i> Handle, thermostat seal installer J7079-2 Thermostat seal installer J8550</p> <p><i>Supplies</i> Adhesive-sealant, silicone, Item 4, Appendix C Compound, sealing, pipe thread, Item 18, Appendix C</p> <p><i>Personnel Required</i> MOS 63S, Heavy wheel vehicle mechanic</p> | <p><i>References</i> None</p> <p><i>Equipment Condition</i></p> <table style="width: 100%; border-collapse: collapse;"> <thead> <tr> <th style="text-align: left;"><i>TM or Para</i></th> <th style="text-align: left;"><i>Condition Description</i></th> </tr> </thead> <tbody> <tr> <td>TM 9-2320-279-10</td> <td>Shut off engine.</td> </tr> <tr> <td>Para 6-2</td> <td>Cooling system drained.</td> </tr> <tr> <td>Para 7-91</td> <td>Batteries disconnected.</td> </tr> </tbody> </table> <p><i>Special Environmental Conditions</i> None</p> <p><i>General Safety Instructions</i> None</p> | <i>TM or Para</i> | <i>Condition Description</i> | TM 9-2320-279-10 | Shut off engine. | Para 6-2 | Cooling system drained. | Para 7-91 | Batteries disconnected. |
| <i>TM or Para</i> | <i>Condition Description</i> | | | | | | | | |
| TM 9-2320-279-10 | Shut off engine. | | | | | | | | |
| Para 6-2 | Cooling system drained. | | | | | | | | |
| Para 7-91 | Batteries disconnected. | | | | | | | | |

Cooling System Maintenance Instructions (Cent)

a. Removal.

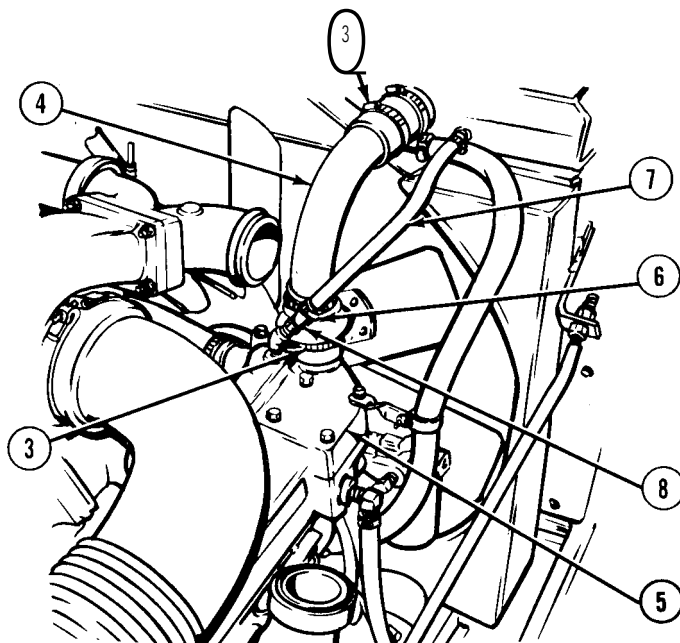


TA182192

(1) Remove two clamps (1) and exhaust pipe (2)

(2) Loosen two clamps (3) and remove upper water tube (4) from thermostat housing cover (5).

(3) Loosen clamp (6) and remove hose (7) from fitting (8).

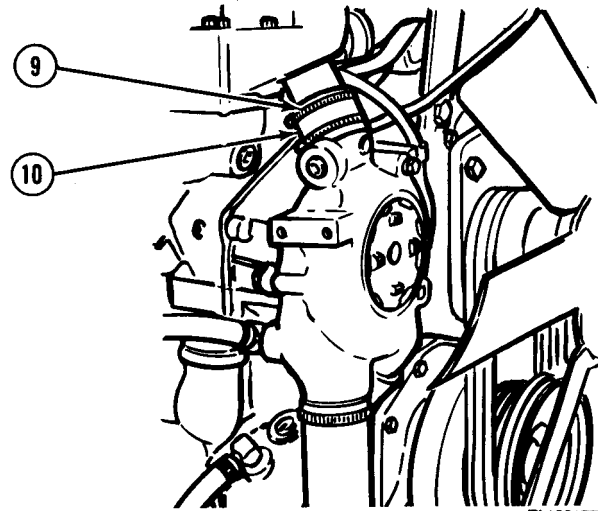


TA182191

Cooling System Maintenance Instructions (Cent)

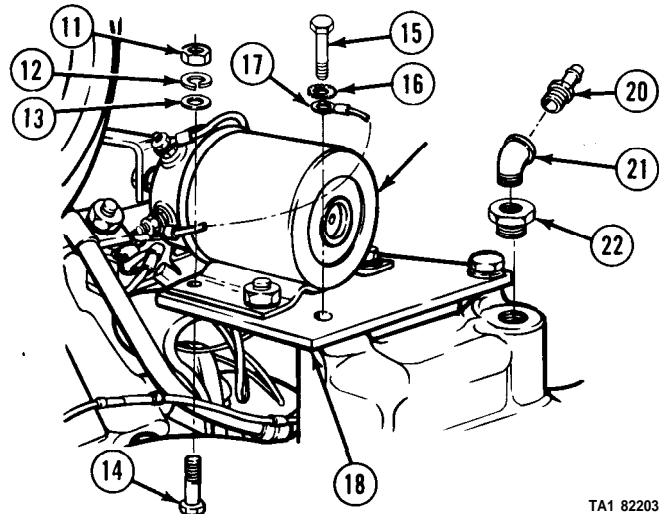
6-9. RIGHT THERMOSTAT, COVER, AND HOUSING REMOVAL/INSTALLATION (CONT.)

- (4) Loosen clamp (9) on water hose (10).



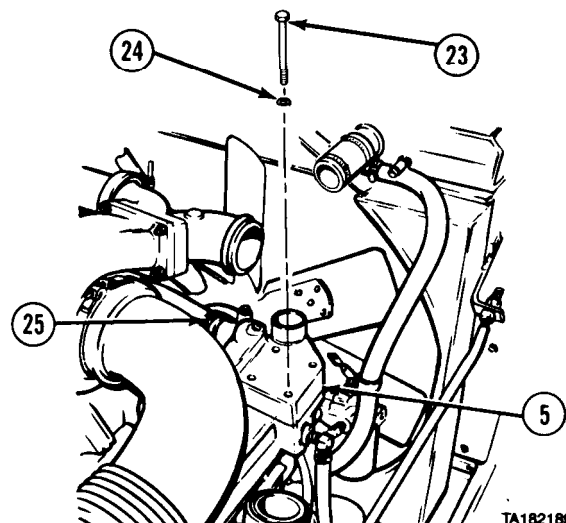
TA182177

- (5) Remove nut (11), lockwasher (12), washer (13), and screw (14).
- (6) Remove two screws (15), lockwashers (16), and one ground wire (17) from bracket (18).
- (7) Move bracket (18) and solenoid (19) out of way.
- (8) Remove fitting (20), elbow (21), and reducer bushing (22).



TA1 82203

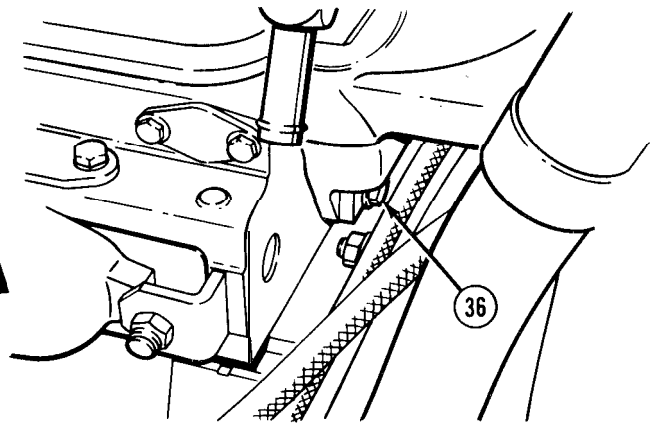
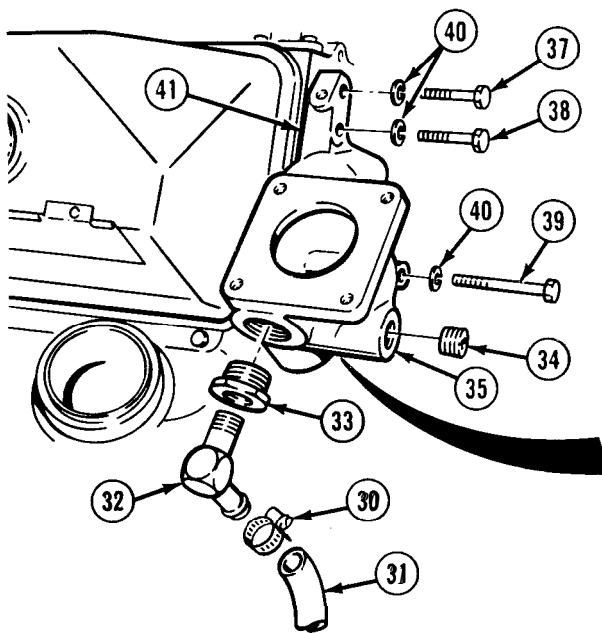
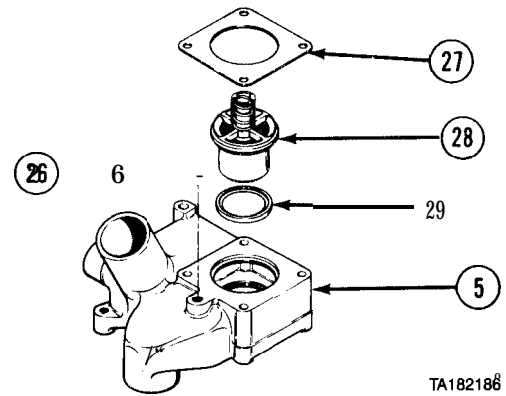
- (9) Remove four screws (23) and lockwashers (24).
- (10) Loosen clamp (25).
- (11) Loosen and remove thermostat housing cover (5).



TA182189

Cooling System Maintenance Instructions (Cont)

- (12) Turn thermostat housing cover (5) over and remove pipe plug (26).
- (13) Remove gasket (27) and thermostat (28).
- (14) Remove seal (29) from thermostat housing cover (5).

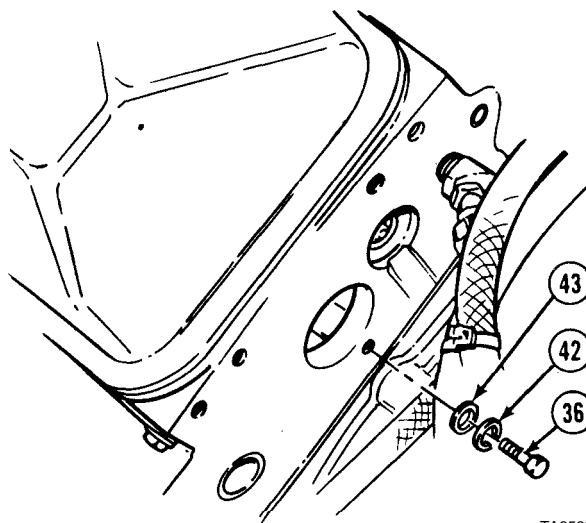


- (15) Loosen clamp (30) and remove hose (31) from elbow (32).
- (16) Remove elbow (32), adapter (33), and plug (34) from thermostat housing (35).
- (17) Loosen screw (36).
- (18) Remove three screws (37, 38, and 39) and lockwashers (40).
- (19) Remove thermostat housing (35) and gasket (41).

Cooling System Maintenance Instructions (Cont)

6-9. RIGHT THERMOSTAT, COVER, AND HOUSING REMOVAL/INSTALLATION(CONT).

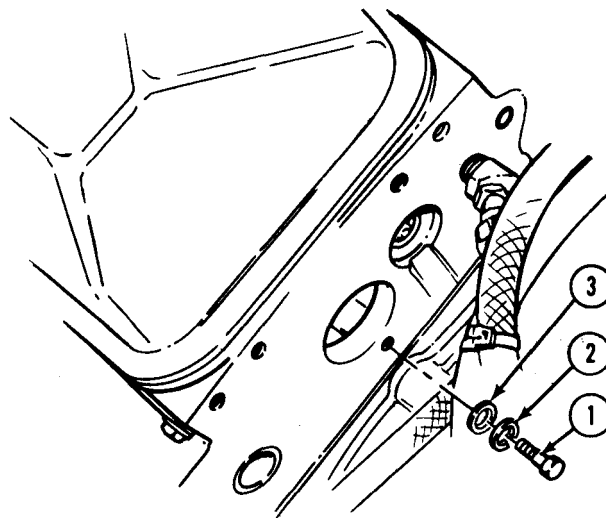
- (20) Remove screw (36), lockwasher (42), and washer (43).



TA356992

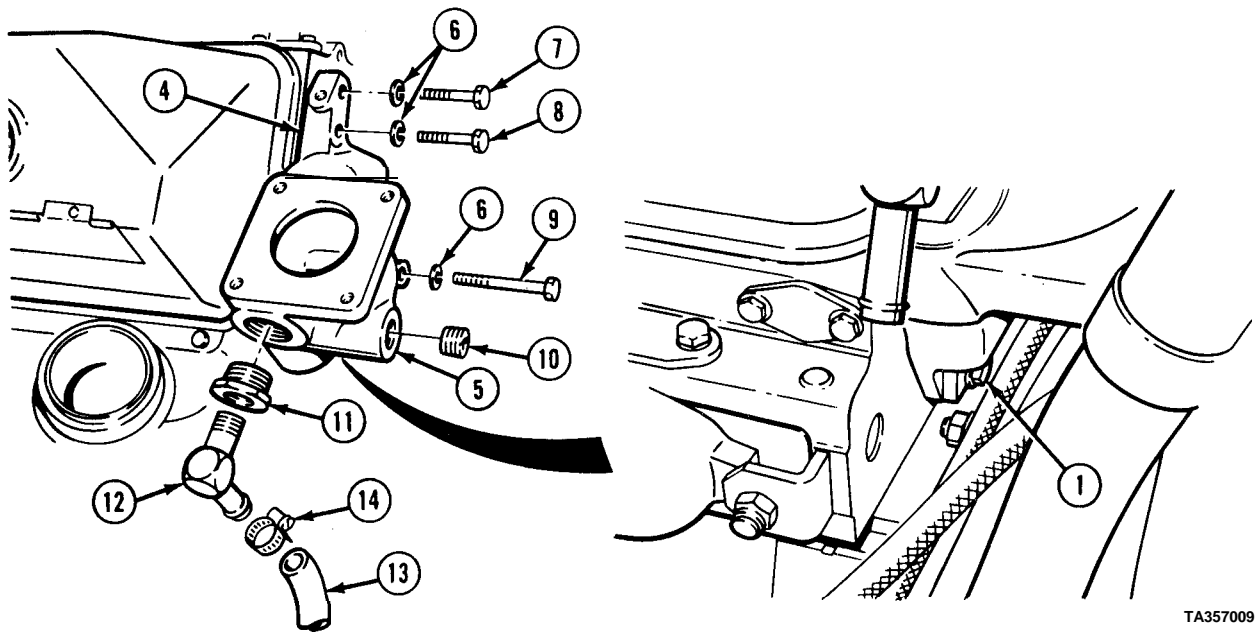
b. Installation.

- (1) Install screw (1), lockwasher (2), and washer (3) about three turns deep.



TA357008

Cooling System Maintenance Instructions (Cont)



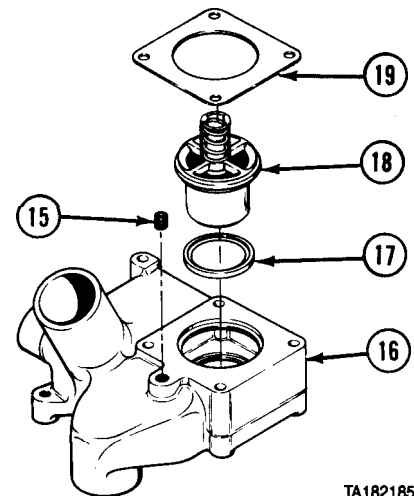
TA357009

- (2) Coat gasket (4) with silicone adhesive-sealant and install on thermostat housing (5).
- (3) Install thermostat housing (5) and gasket (4) with three lockwashers (6) and screws (7, 8, and 9).
- (4) Tighten screw (1).
- (5) Coat threads of plug (10), adapter (11), and elbow (12) with pipe thread sealing compound and install in thermostat housing (5).
- (6) Install hose (13) on elbow (12). Tighten clamp (14).

WARNING

Adhesives, solvents, and sealing compounds can burn easily, can give off harmful vapors, and are harmful to skin and clothing. To avoid injury or death, keep away from open fire and use in well-ventilated area. If adhesive, solvent, or sealing compound gets on skin or clothing, wash immediately with soap and water.

- (7) Coat threads of pipe plug (15) with pipe thread sealing compound, and install in thermostat housing cover (16).
- (8) Using installer and handle, install seal (17) with lip toward inside of thermostat housing cover (16).
- (9) Install thermostat (18), pressing down until it seats in thermostat housing cover (16).
- (10) Coat gasket (19) with silicone adhesive-sealant, and install gasket on thermostat housing cover (16).

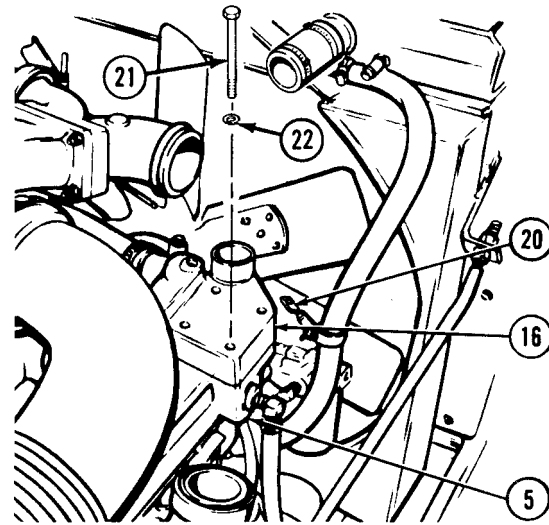


TA182185

Cooling System Maintenance Instructions (Cent)

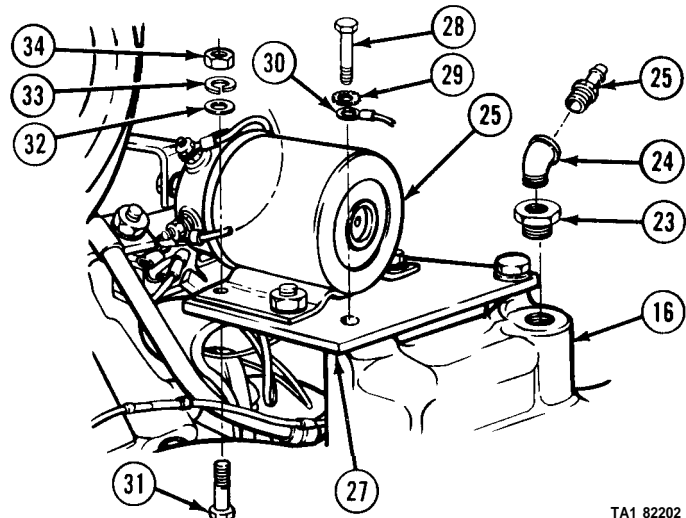
6-9. RIGHT THERMOSTAT, COVER, AND HOUSING REMOVAL/INSTALLATION (CONT).

- (11) Position thermostat housing cover (16) on thermostat housing (5).
- (12) Position bracket (20) on thermostat housing cover (16).
- (13) Install four screws (21) and lockwashers (22).
- (14) Tighten screws (21) to 23 to 26 lb-ft (31.2 to 35.3 N·m) using cross-corner sequence.



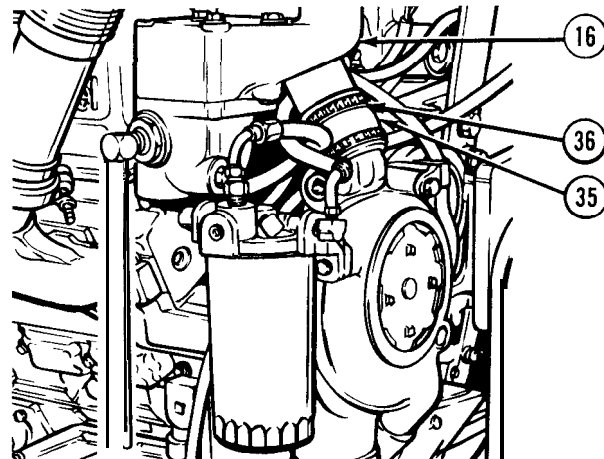
TA182188

- (15) Coat threads of reducer bushing (23), elbow (24), and fitting (25) with pipe thread sealing compound, and install in top of thermostat housing cover (16).
- (16) Move solenoid (26) and bracket (27) in position.
- (17) Install two screws (28), lockwashers (29), and one ground wire (30).
- (18) Install screw (31), washer (32), lockwasher (33), and nut (34).



TA1 82202

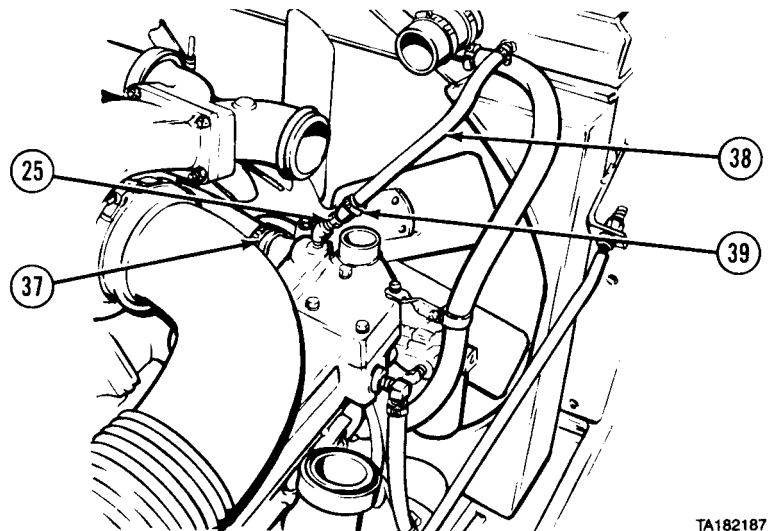
- (19) Secure water hose (35) by tightening clamp (36) at bottom of thermostat housing cover (16).



TA182176

Cooling System Maintenance Instructions (Cont)

- (20) Tighten clamp (37).
- (21) Install hose (38) to fitting (25) and tighten clamp (39).

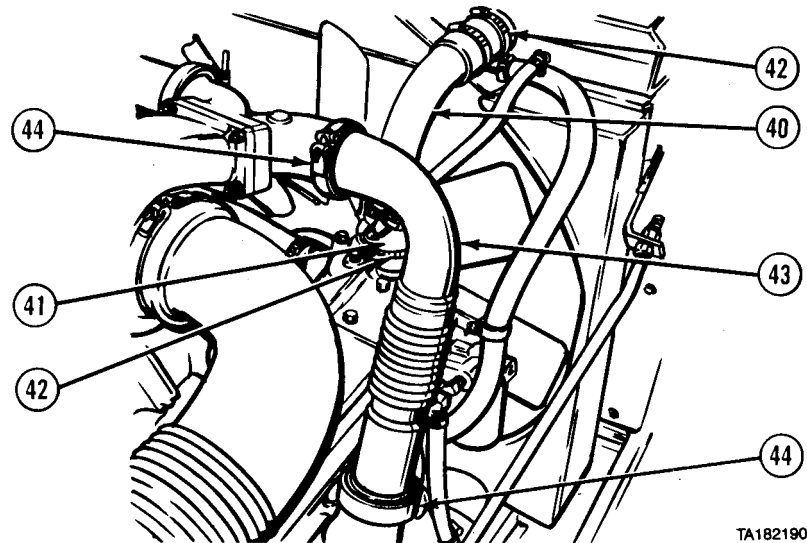


TA182187

- (22) Install upper water tube (40) and hose (41) and tighten two clamps (42).
- (23) Install exhaust pipe (43) and tighten two clamps (44).

c. **Follow-on** Maintenance.

- (1) Fill cooling system (para 6-2).
- (2) Adjust engine stop solenoid (para 4-8).
- (3) Connect batteries (para 7-91).
- (4) Start engine and check for leaks (TM 9-2320-279-10).
- (5) Check if WATER TEMP gage indicates normal operating temperature (TM 9-2320-279-10).
- (6) Shut off engine (TM 9-2320-279-10).



TA182190

END OF TASK

Cooling System Maintenance Instructions (Cont)

Section IV. FAN

| | |
|---|--|
| 6-10. FAN CONTROL VALVE REMOVAL/INSTALLATION. | |
| This task covers: | |
| a. Removal | c. Follow-on Maintenance |
| b. Installation | |
| INITIAL SETUP | |
| <i>Models</i> | <i>References</i> |
| All | None |
| <i>Test Equipment</i> | <i>Equipment Condition</i> |
| None | <i>TM or Para</i> <i>Condition Description</i> |
| <i>Special Tools</i> | TM 9-2320-279-10 Shut off engine. |
| None | TM 9-2320-279-10 Engine cover open. |
| <i>Supplies</i> | Para 6-2 Cooling system drained. |
| Compound, sealing, pipe thread, Item 18, Appendix C | TM 9-2320-279-10 Air system drained. |
| Tags, identification, Item 48, Appendix C | <i>Special Environmental Conditions</i> |
| <i>Personnel Required</i> | None |
| MOS 63S, Heavy wheel vehicle mechanic | <i>General Safety Instructions</i> |
| | None |

Cooling System Maintenance Instructions (Cont)

a. Removal.

NOTE

• Vehicles may have old or new model valves. Model A valve must be replaced by Model B or Model A valve.

Ž Model B must be replaced by a Model B valve.

Ž Tag and mark air lines before removal.

- (1) Remove two air lines (1 and 2).
- (2) Remove two elbows (3).
- (3) Remove fan control valve (4) from thermostat (5).

b. Installation.

WARNING

Adhesives, solvents, and sealing compounds can burn easily, can give off harmful vapors, and are harmful to skin and clothing. To avoid injury or death, keep away from open fire and use in well-ventilated area. If adhesive, solvent, or sealing compound gets on skin or clothing, wash immediately with soap and water.

- (1) Apply pipe thread sealing compound to threads of fan control valve (4).

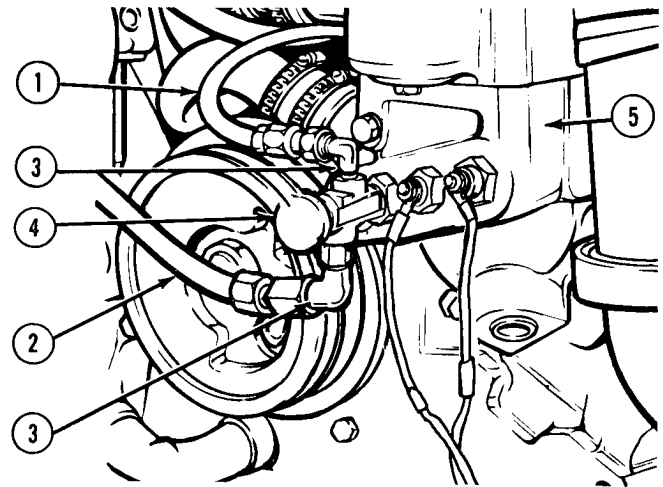
CAUTION

Do not tighten fan control valve by placing wrench on housing or fan control valve may be damaged.

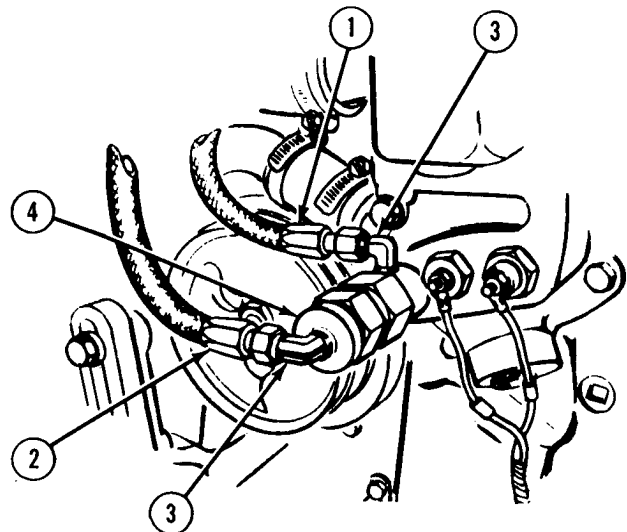
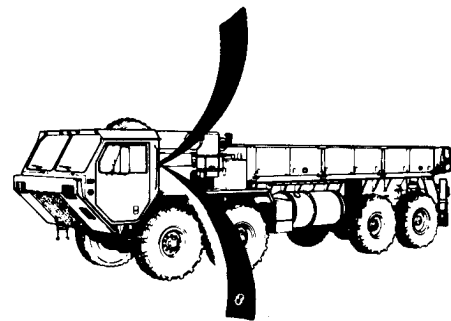
- (2) Install fan control valve (4) in thermostat (5).
- (3) Apply pipe thread sealing compound to threads of elbows (3) and install elbows.
- (4) Connect two air lines (1 and 2).

c. Follow-on Maintenance.

- (1) Fill cooling system (para 6-2).
- (2) Close engine cover (TM 9-2320-279-10).
- (3) Start engine and build up air pressure (TM 9-2320-279-10).
- (4) Check operation of fan control valve (TM 9-2320-279-10).
- (5) Shut off engine (TM 9-2320-279-10).



MODEL A



MODEL B

TA182066

END OF TASK

Cooling System Maintenance Instructions (Cont)

6-11. FAN REMOVAL/INSTALLATION.

This task covers:

- a. Removal
- b. Installation
- c. Follow-on Maintenance

INITIAL SETUP

Models

All

Test Equipment

None

Special Tools

None

Supplies

None

Personnel Required

MOS 63S, Heavy wheel vehicle mechanic (2)

References

None

Equipment Condition

| <i>TM or Para</i> | <i>Condition Description</i> |
|-------------------|------------------------------|
| TM 9-2320-279-10 | Shut off engine. |
| Para 6-2 | Cooling system drained. |

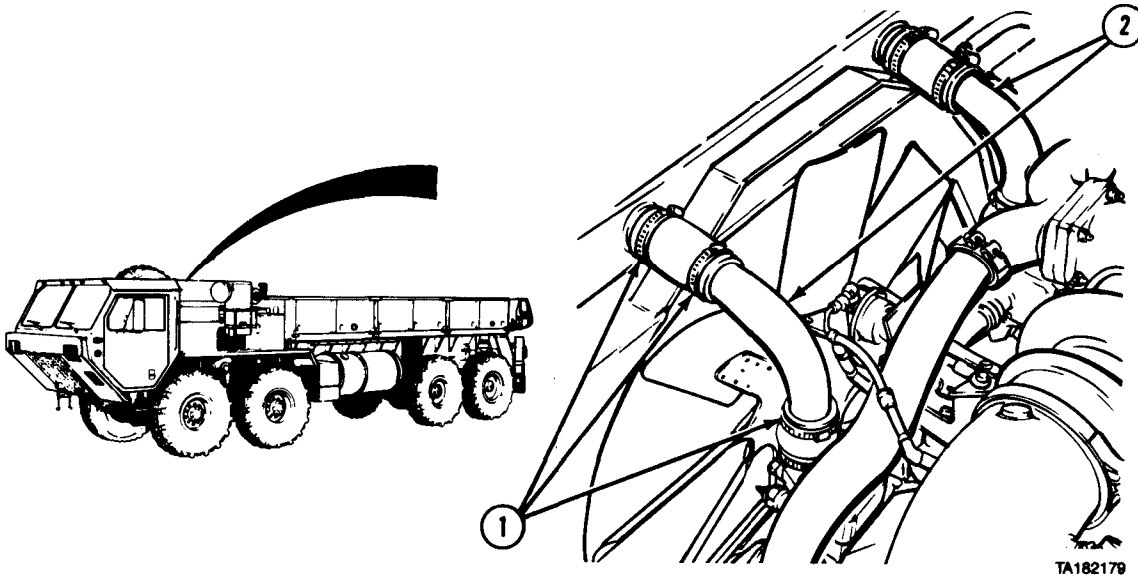
Special Environmental Conditions

None

General Safety Instructions

None

a. Removal.



(1) Loosen six hose clamps (1) on two upper radiator hoses (2).

(2) Turn two upper radiator hoses (2) toward rear of vehicle.

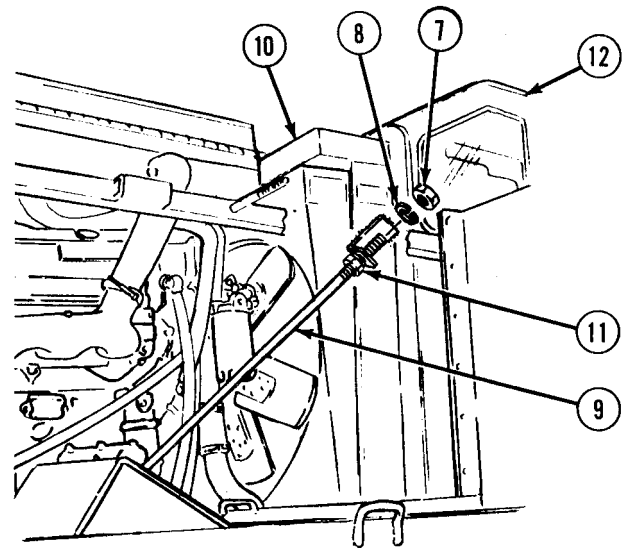
(3) Loosen clamp (3) and remove thermostat hose (4).

(4) Loosen clamp (5) and remove heater hose (6).

TA182179

Cooling System Maintenance Instructions (Cont)

- (5) Remove two nuts (7) and washers (8) from tie rods (9) on both sides of radiator (10).
- (6) Turn lower nuts (11) clockwise to force radiator (10) forward until it touches cab (12).



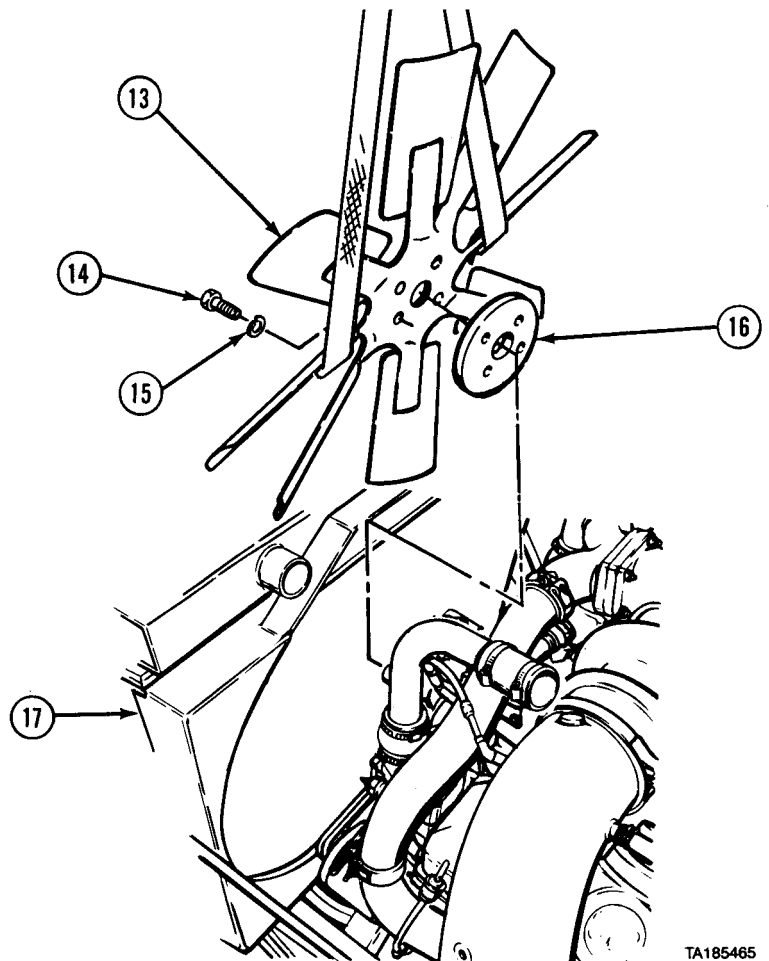
TA182204

- (7) Support fan (13) with suitable lifting device.

CAUTION

Spacer must be held in place or caught as fan is removed, or spacer may fall off and be damaged.

- (8) Remove four screws (14) and lockwashers (15).
- (9) Soldier A and Soldier B remove fan (13) and spacer (16).
- (10) Soldier B holds fan (13) clear of shroud (17).
- (11) Soldier A lifts fan (13) out with lifting device.



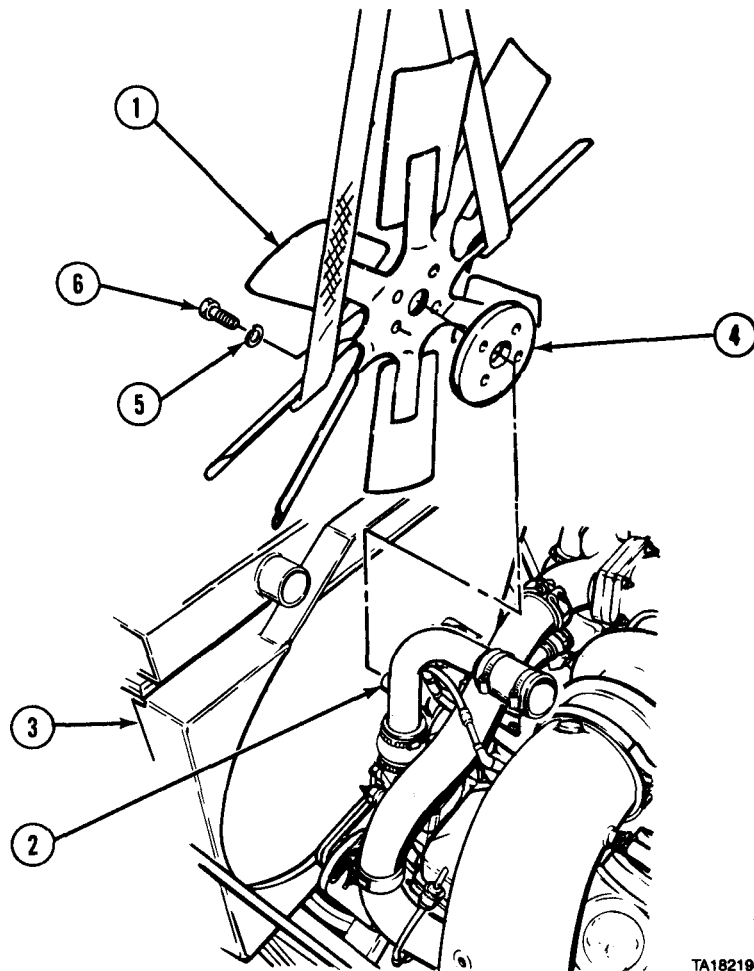
TA185465

Cooling System Maintenance Instructions (Cont)

6-11. FAN REMOVAL/INSTALLATION (CONT).

b. Installation.

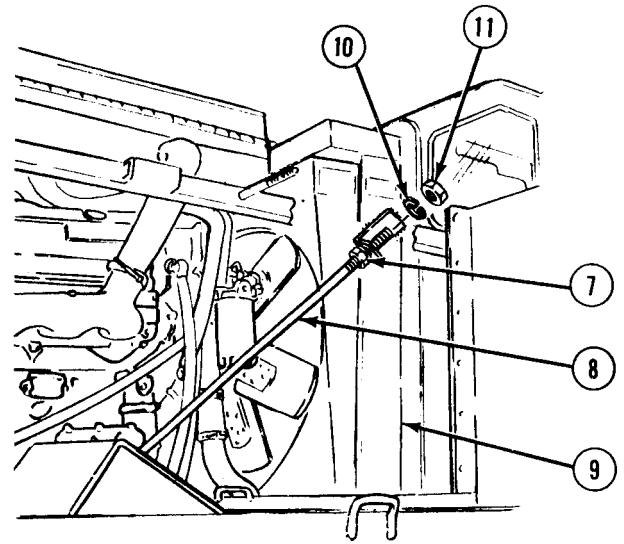
- (1) Soldier A lowers fan (1) between fan clutch (2) and shroud (3) with suitable lifting device.
- (2) Soldier A and Soldier B install spacer (4), fan (1), four lockwashers (5), and screws (6) to fan clutch (2).



TA182198

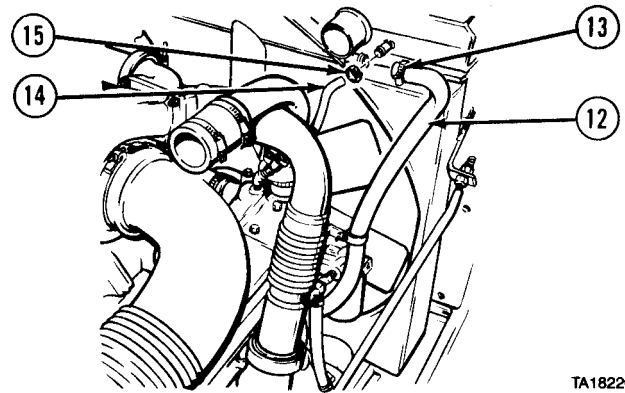
Cooling System Maintenance Instructions (Cont)

- (3) Turn nuts (7) on tie rods (8) on both sides of radiator (9) counterclockwise to straighten radiator (9).
- (4) Install two washers (10) and nuts (11) on tie rods (8).



TA182205

- (5) Install heater hose (12) and tighten clamp (13).
- (6) Install thermostat hose (14) and tighten clamp (15).

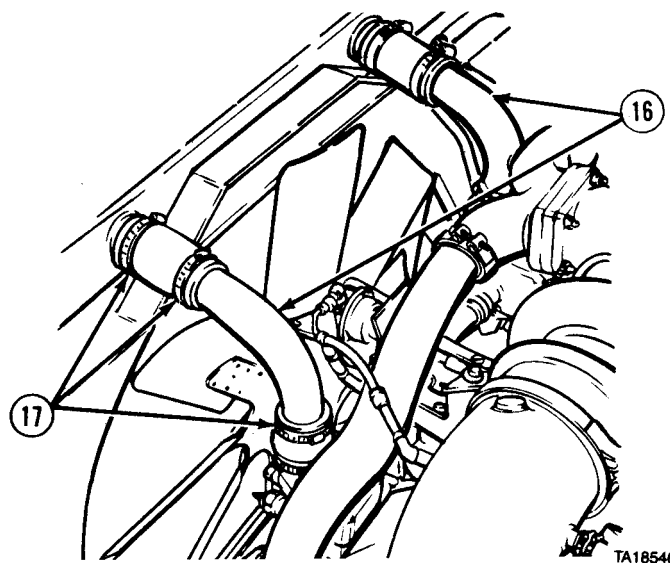


TA182207

- (7) Install two upper radiator hoses (16) and tighten six clamps (17).

c. *Follow-on Maintenance.* Fill cooling system (para 6-2).

END OF TASK



TA185486

Cooling System Maintenance Instructions (Cont)

6-12. FAN CLUTCH REMOVAL/INSTALLATION.

This task covers:

- a. Removal
- b. Installation
- c. Follow-on Maintenance

INITIAL SETUP

Models

All

References

None

Test Equipment

None

Equipment Condition

| <i>TM or Para</i> | <i>Condition Description</i> |
|-------------------|------------------------------|
| TM 9-2320-279-10 | Shut off engine. |
| Para 6-11 | Fan removed. |
| Para 6-17 | Fan belts removed. |

Special Tools

None

Supplies

Compound, sealing, pipe thread, Item 18, Appendix C
 Tags, identification, Item 48,. Appendix C

Special Environmental Conditions

None

Personnel Required

MOS 63S, Heavy wheel vehicle mechanic

General Safety Instructions

None

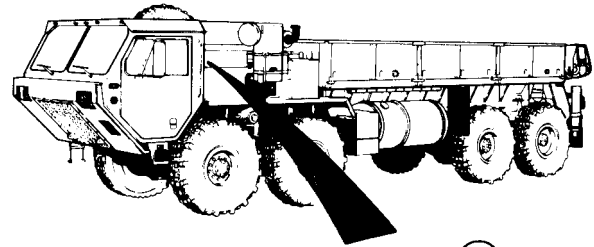
Cooling System Maintenance Instructions (Cont)

a. Removal.

NOTE

Tag and mark oil lines before disconnecting.

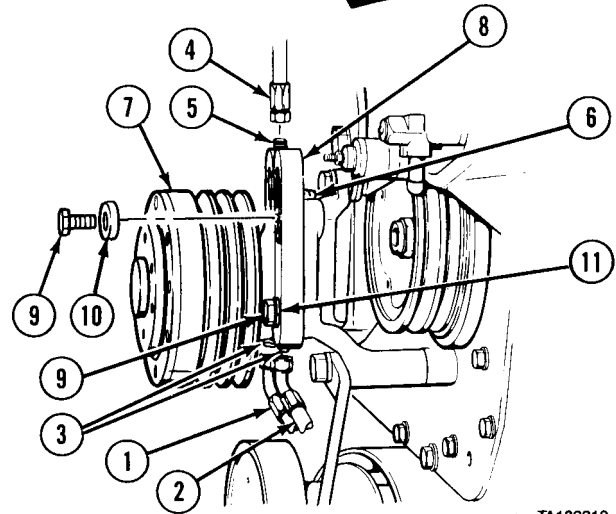
- (1) Disconnect oil lines (1 and 2) from fittings (3).
- (2) Disconnect air line (4) from fitting (5).
- (3) Remove adjusting screw (6).
- (4) Support fan clutch (7) and pull fan clutch away from bracket (8) as four screws (9) are loosened.



NOTE

Bottom screws cannot be removed from fan clutch.

- (5) Remove two top mounting screws (9) and spacers (10).
- (6) Remove fan clutch (7).
- (7) Remove fittings (3 and 5) from fan clutch (7).



TA162210

b. Installation.

WARNING

Adhesives, solvents, and sealing compounds can burn easily, can give off harmful vapors, and are harmful to skin and clothing. To avoid injury or death, keep away from open fire and use in well-ventilated area. If adhesive, solvent, or sealing compound gets on skin or clothing, wash immediately with soap and water.

- (1) Coat pipe threads of fittings (3 and 5) with pipe thread sealing compound and install in fan clutch (7).
- (2) Install fan clutch (7) on bracket (8) with lower two screws (9) and lockwashers (11). Do not tighten screws.
- (3) Install top two mounting screws (9) and spacers (10). Do not tighten screws.
- (4) Connect oil lines (1 and 2) to lower fittings in fan clutch (7).
- (5) Connect air line (4) to upper fitting in fan clutch (7).
- (6) Install adjusting screw (6).

c. Follow on Maintenance.

- (1) Install fan belts (para 6-17).
- (2) Adjust fan belts (para 6-16).
- (3) Install fan (para 6-11).

END OF TASK

Cooling System Maintenance Instructions (Cont)

6-13. FAN CLUTCH TO ENGINE BLOCK HOSE REMOVAL/INSTALLATION.

This task covers:

- a. Removal
- b. Installation
- c. Follow-on Maintenance

INITIAL SETUP

Models

All

Test Equipment

None

Special Tools

None

Supplies

Ties, cable, plastic, Item 52, Appendix C

Personnel Required

MOS 63S, Heavy wheel vehicle mechanic

References

None

Equipment Condition

TM or Para

Condition Description

TM 9-2320-279-10 Shut off engine.

TM 9-2320-279-10 Engine side panel removed.
Engine cool.

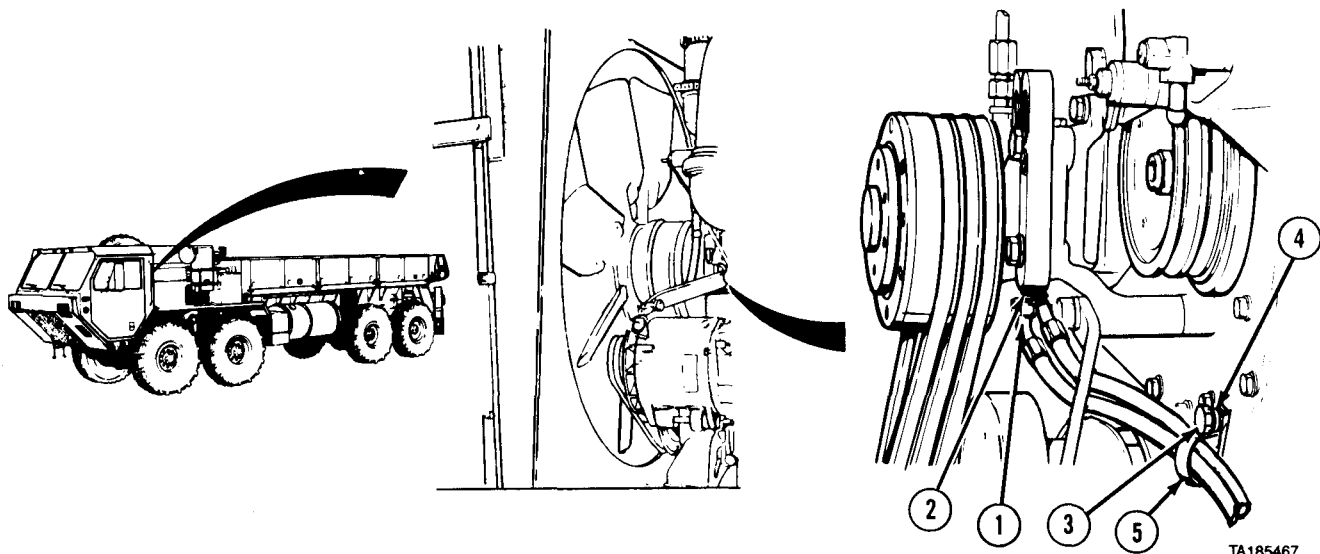
Special Environmental Conditions

None

General Safety Instructions

None

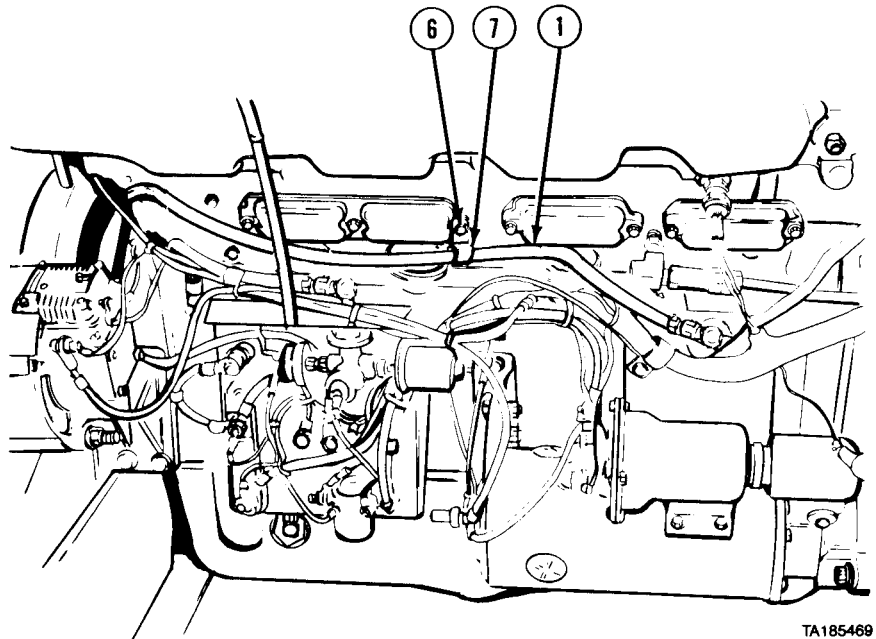
a. Removal.



- (1) Remove hose (1) from fitting (2).
- (2) Remove screw (3), lockwasher (4), and cushion clamp (5).
- (3) Remove hose (1) from cushion clamp (5).

Cooling System Maintenance Instructions (Cont)

- (4) Remove screw (6) and cushion clamp (7).
- (5) Remove hose (1) from cushion clamp (7).

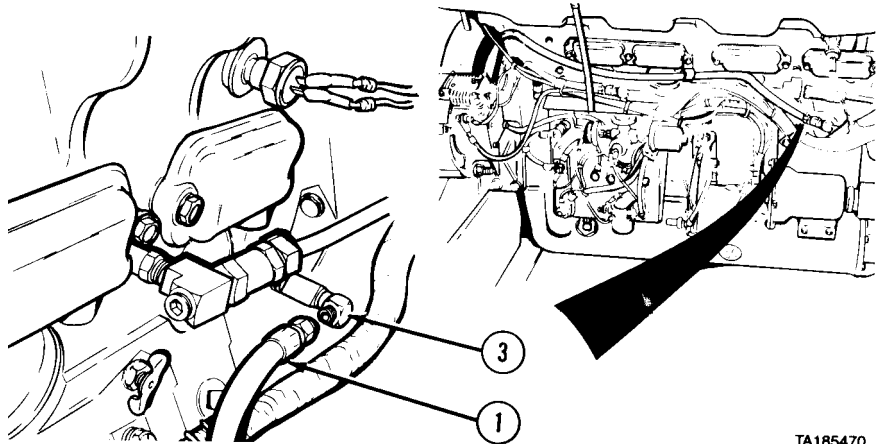


TA185469

NOTE

Cut plastic cable ties as needed.

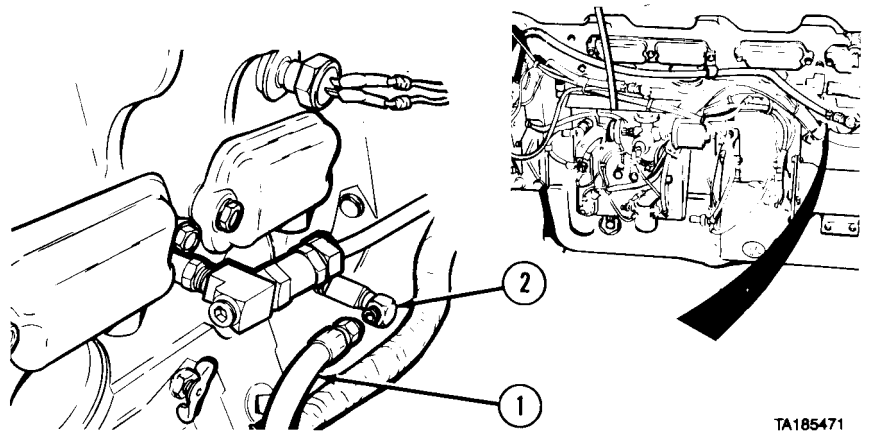
- (6) Remove hose (1) from fitting (3).



TA185470

b. Installation.

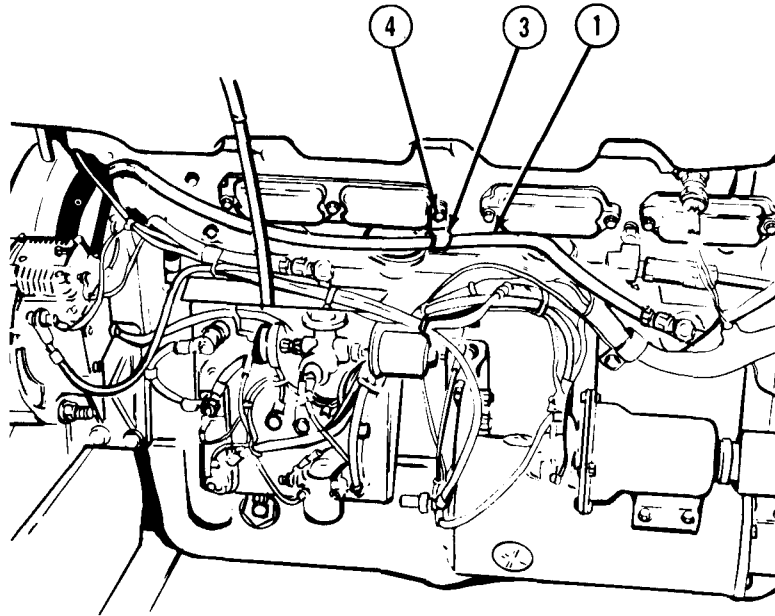
- (1) Install hose (1) on fitting (2).



TA185471

Cooling System Maintenance Instructions (Cont)

6-13. FAN CLUTCH TO ENGINE BLOCK HOSE REMOVAL/INSTALLATION (CONT).



TA185472

- (2) Install hose (1) in cushion clamp (3).
- (3) Install cushion clamp (3) with screw (4).

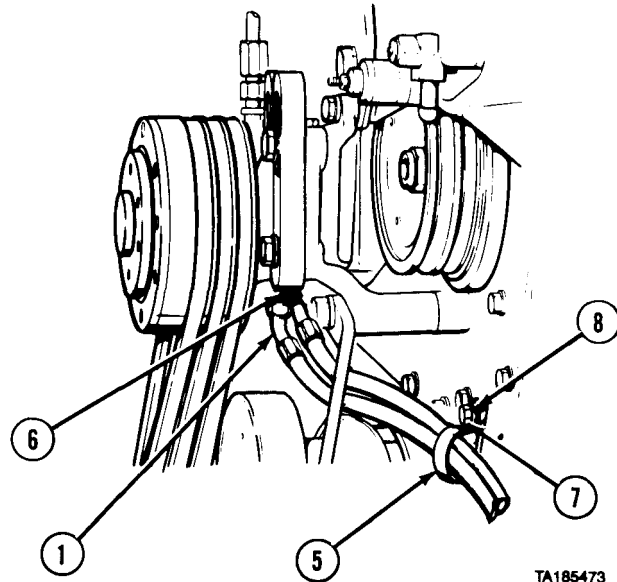
NOTE

Install plastic cable ties as needed.

- (4) Install hose (1) in cushion clamp (5).
- (5) Install hose (1) in fitting (6).
- (6) Install cushion clamp (5) with screw (7) and lockwasher (8).

c. Follow-on Maintenance.

- (1) Check engine oil level (LO 9-2320-279-12).
- (2) Start engine (TM 9-2320-279-10).
- (3) Check for leaks (TM 9-2320-279-10).
- (4) Install engine side panel (TM 9-2320-279-10).
- (5) Shut off engine (TM 9-2320-279-10).



TA185473

END OF TASK

Cooling System Maintenance Instructions (Cont)

| | |
|---|--|
| 6-14. ALTERNATOR BELT ADJUSTMENT. | |
| This task covers: | |
| <ul style="list-style-type: none"> a. Adjustment b. Follow-on Maintenance | |
| INITIAL SETUP | |
| <i>Models</i> | <i>References</i> |
| All | None |
| <i>Test Equipment</i> | <i>Equipment Condition</i> |
| None | |
| <i>Special Tools</i> | <i>TM or Para</i> <i>Condition Description</i> |
| Gage, belt tension J-23600 | TM 9-2320-279-10 Shut off engine. |
| | TM 9-2320-279-10 Engine side panel removed. |
| <i>Supplies</i> | <i>Special Environmental Conditions</i> |
| None | None |
| <i>Personnel Required</i> | <i>General Safety Instructions</i> |
| MOS 63S, Heavy wheel vehicle mechanic | None |

a. Adjustment.

- (1) Loosen nut (1) and washer (2) on pivot screw (3) under alternator (4).

NOTE

- If truck is equipped with 65 amp or 100 amp alternator, perform step (2).
- If truck is equipped with 130 amp alternator, perform step (2.1).

- (2) Loosen adjustment screw (5), lockwasher (5.1) and washer (5.2) at top of alternator (4).

- (2.1) Loosen adjustment screw (5), lockwasher (5.1), washer (5.2) and nut (5.3) at top of alternator (4).

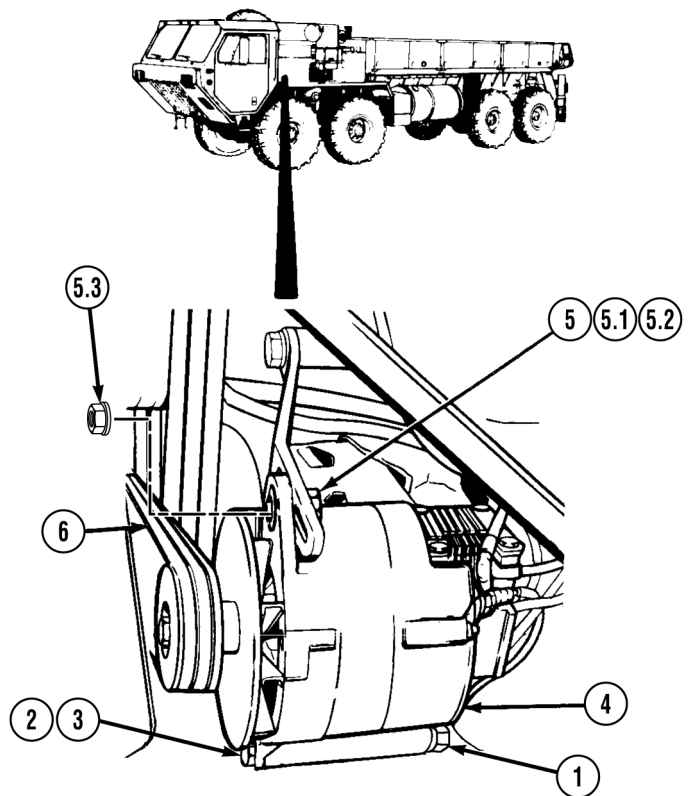
- (3) Adjust two belts (6) using belt tension gage to 70 to 90 lb (310 to 400 N).

NOTE

- If truck is equipped with 65 amp or 100 amp alternator, perform step (4).
- If truck is equipped with 130 amp alternator, perform step (4.1).

- (4) Tighten washer (5.2), lockwasher (5.1), and adjustment screw (5) at top of alternator (4).

- (4.1) Tighten nut (5.3), washer (5.2), lockwasher (5.1), and adjustment screw (5) at top of alternator (4).

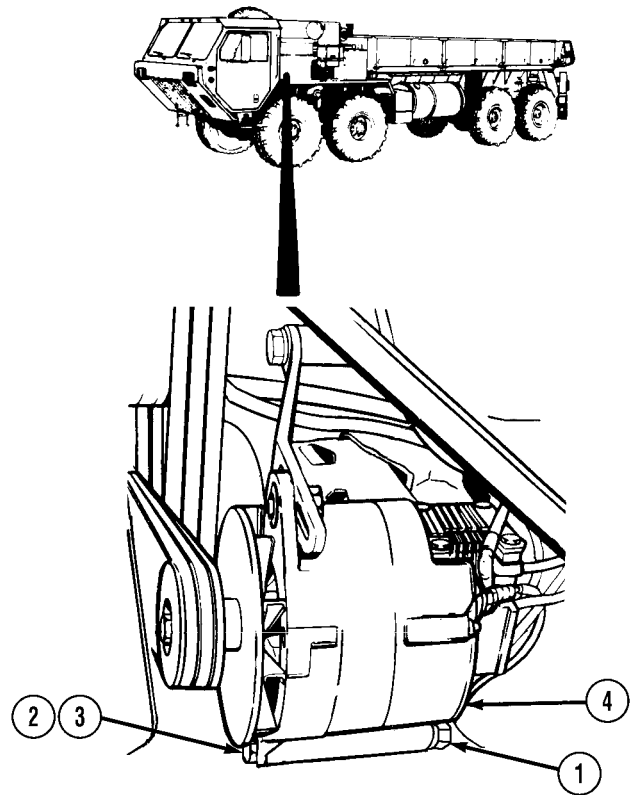


Cooling System Maintenance Instructions (Cont)

- (5) Tighten pivot screw (3), washer (2) and nut (1) under alternator (4) to 50 to 55 lb (68 to 75 N).

b. Follow-on Maintenance. Install engine side panel (TM 9-2320-279-10).

END OF TASK



Cooling System Maintenance Instructions (Cont)

| | |
|--|--|
| 6-15. ALTERNATOR BELT REMOVAL/INSTALLATION. | |
| This task covers: | |
| a. Removal | c. Follow-on Maintenance |
| b. Installation | |
| INITIAL SETUP | |
| <i>Models</i> All | <i>References</i> None |
| <i>Test Equipment</i> None | <i>Equipment Condition</i> |
| <i>Special Tools</i> None | <i>TM or Para</i> <i>Condition Description</i> TM 9-2320-279-10 Shut off engine. TM 9-2320-279-10 Engine side panel removed. |
| <i>Supplies</i> None | <i>Special Environmental Conditions</i> None |
| <i>Personnel Required</i> MOS 63S, Heavy wheel vehicle mechanic | <i>General Safety Instructions</i> None |

a. Removal.

- (1) Loosen nut (1) and washer (2) on pivot screw (3) at bottom of alternator (4).

NOTE

- If truck is equipped with 65 amp or 100 amp alternator, perform step (2).
- If truck is equipped with 130 amp alternator, perform step (2.1).

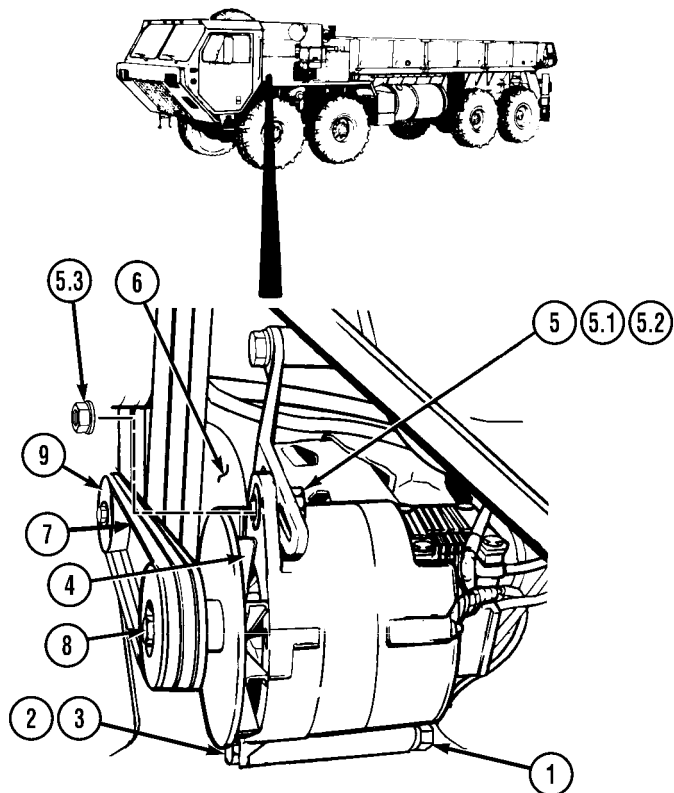
- (2) Loosen adjustment screw (5), lockwasher (5.1), and washer (5.2) at top of alternator (4).
- (2.1) Loosen adjustment screw (5), lockwasher (5.1), washer (5.2), and nut (5.3) at top of alternator (4).
- (3) Swing alternator (4) in toward engine (6) and remove belts (7).

b. Installation.

Install belts (7) on alternator pulley (8) and engine pulley (9).

c. Follow-on Maintenance.

- (1) Adjust alternator belts (para 6-14).
- (2) Install engine side panel (TM 9-2320-279-10).



END OF TASK

Cooling System Maintenance Instructions (Cont)

6-16. FAN BELT ADJUSTMENT.

This task covers:

- a. Adjustment
- b. Follow-on Maintenance

INITIAL SETUP

Models
All

Test Equipment
None

Special Tools
Gage, belt tension J23600

Supplies
None

Personnel Required
MOS 63S, Heavy wheel vehicle mechanic

References
None

| <i>Equipment Condition</i> | |
|----------------------------|------------------------------|
| <i>TM or Para</i> | <i>Condition Description</i> |
| TM 9-2320-279-10 | Shut off engine. |
| TM 9-2320-279-10 | Engine side panel removed. |

Special Environmental Conditions
None

General Safety Instructions
None

a. Adjustment.

- (1) Loosen four screws (1) on bracket (2).

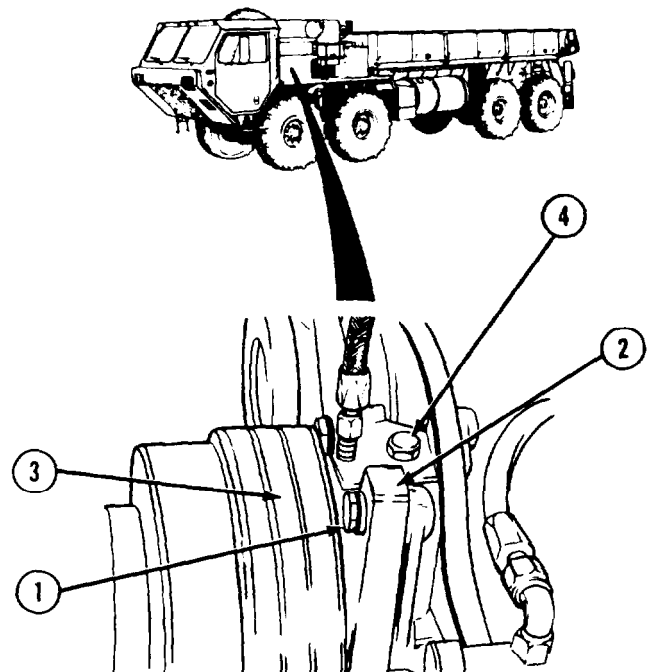
NOTE

Adjust one belt to get proper tension for all three belts.

- (2) Adjust belts (3) using belt tension gage to 70 to 90 lb (310 to 400 N).
- (3) Turn adjustment screw (4) clockwise to tighten belt tension, counterclockwise to loosen.
- (4) Tighten four screws (1).

b. Follow-on Maintenance. Install engine side panel (TM 9-2320-279-10).

END OF TASK



Cooling System Maintenance Instructions (Cont)

6-17. FAN BELT REMOVAL/INSTALLATION.

This task covers:

- a. Removal
- b. Installation
- c. Follow-on Maintenance

INITIAL SETUP

Models

All

Test Equipment

None

Special Tools

None

Supplies

None

Personnel Required

MOS 63S, Heavy wheel vehicle mechanic

References

None

Equipment Condition

TM or Para

Condition Description

TM 9-2320-279-10

Shut off engine.

Para 6-15

Alternator belts removed.

Special Environmental Conditions

None

General Safety Instructions

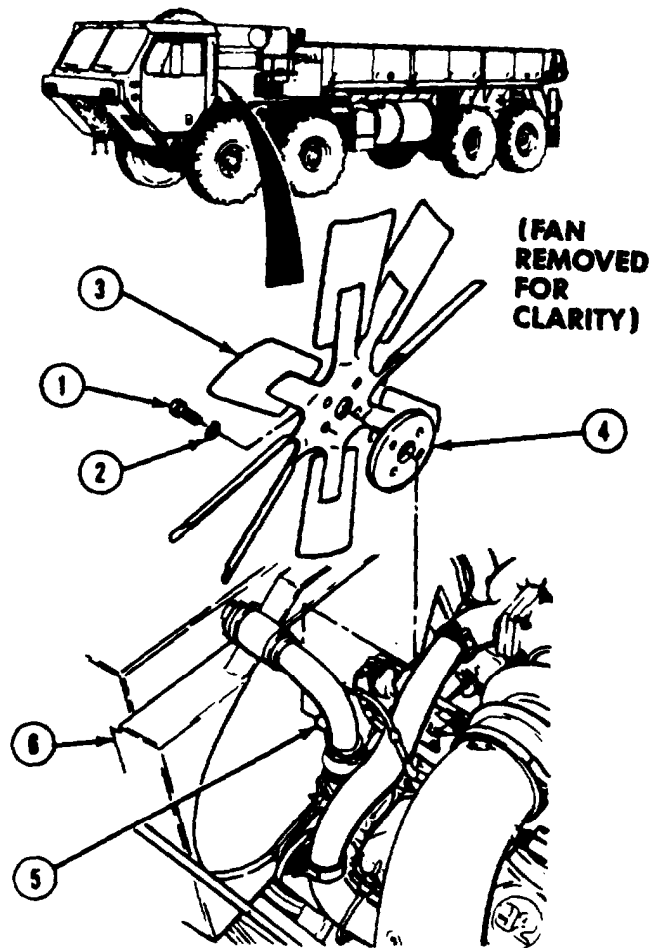
None

a. Removal.

CAUTION

Spacer must be held in place or caught as fan blade is removed, or spacer may fall off and be damaged.

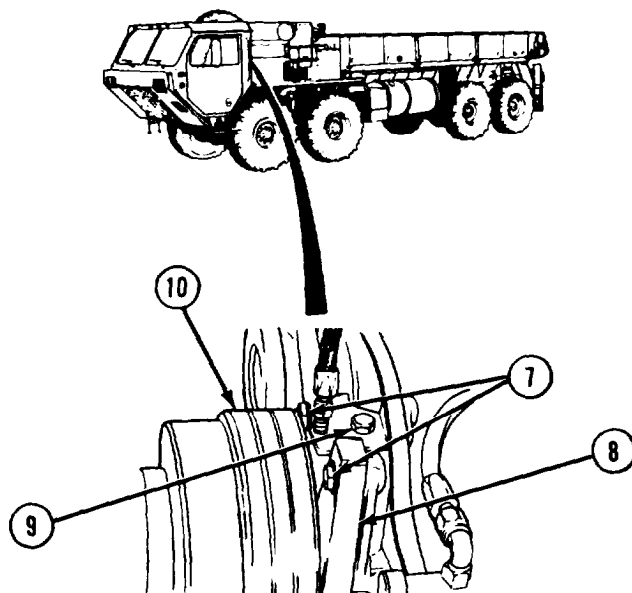
- (1) Remove four screws (1) and lockwashers (2).
- (2) Soldier A and Soldier B remove fan (3) and spacer (4) from engine (5) and set fan down in fan shroud (6).



DA102107

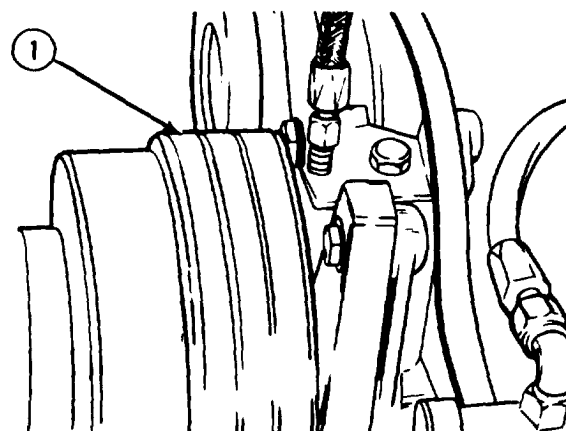
Cooling System Maintenance Instructions (Cont)

- (3) Loosen four screws (7) at each bracket (8).
- (4) Turn adjustment screw (9) counterclockwise to loosen belt tension.
- (5) Remove belts (10).



b. Installation.

- (1) Install belts (1).



Cooling System Maintenance Instructions (Cont)

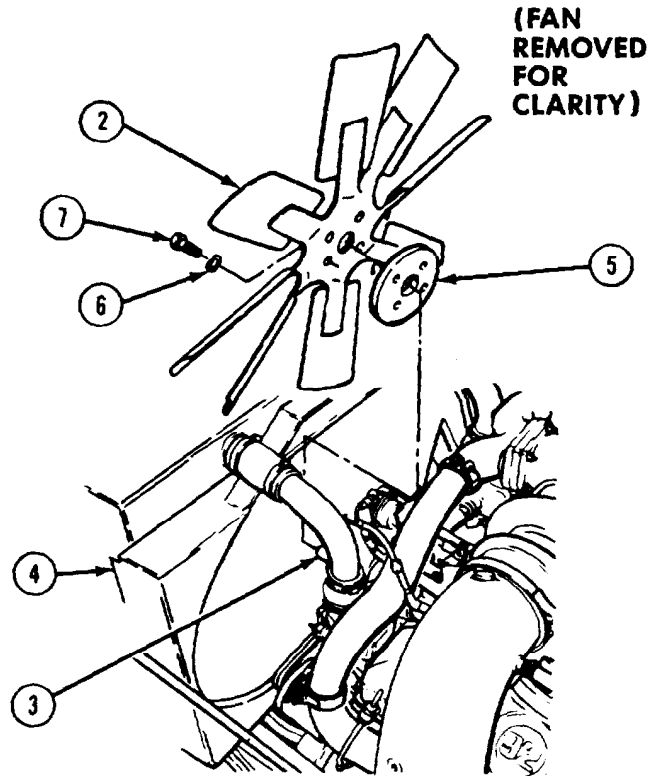
6-17. FAN BELT REMOVAL/INSTALLATION (CONT).

- (2) Soldier A positions fan (2) between fan clutch (3) and shroud (4) with suitable lifting device.
- (3) Soldier A and Soldier B install spacer (5), fan (2), four lockwashers (6), and screws (7) to fan clutch (3).

C. Follow-on Maintenance,

- (1) Adjust fan belt (para 6-16).
- (2) Install alternator belts (para 6-15).
- (3) Adjust alternator belts (para 6-14).

END OF TASK



CHAPTER 7 ELECTRICAL SYSTEM MAINTENANCE

| Contents | Para | Page |
|---|------|--------|
| General | 7-1 | 7-3 |
| Alternator Testing | 7-2 | 7-3 |
| Alternator and Pulley Removal/Installation | 7-3 | 7-5 |
| Alternator Support and Adjusting Strap Removal/Installation | 7-4 | 7-7 |
| Voltage Regulator Removal/Installation | 7-5 | 7-9 |
| Voltage Regulator Adjustment | 7-6 | 7-10.1 |
| Starter Motor Testing | 7-7 | 7-11 |
| Starter Motor Removal/Installation | 7-8 | 7-13 |
| Engine Speed Control Assembly Repair (M983) | 7-9 | 7-15 |
| ENGINE HIGH IDLE Box Removal/Repair/Installation (M977, M985) | 7-10 | 7-25 |
| ENGINE HIGH IDLE Box, Connector, Switches, and Bracket Removal/Installation (Crane Mounted) (M984, M985E1) | 7-11 | 7-32 |
| ENGINE HIGH IDLE Box, Connectors, and Switches Removal/Installation (Tire Davit Mounted) (M984, M985E1) | 7-12 | 7-51 |
| Oil Manifold Removal/Installation | 7-13 | 7-60 |
| Engine Circuit Breaker Removal/Installation | 7-14 | 7-63 |
| Bus Bar Removal/Installation | 7-15 | 7-68 |
| Diode Removal/Installation | 7-16 | 7-72.1 |
| Sender Mounting Bracket Removal/Installation | 7-17 | 7-74 |
| Utility Outlet Removal/Installation | 7-18 | 7-76 |
| Instrument Panel Removal/Installation | 7-19 | 7-79 |
| Oil Pressure Gage Removal/Installation | 7-20 | 7-81 |
| Water Temperature Gage Removal/Installation | 7-21 | 7-82 |
| Transmission Oil Temperature Gage Removal/Installation | 7-22 | 7-84 |
| Fuel Gage Removal/Installation | 7-23 | 7-86 |
| Voltmeter Removal/Installation | 7-24 | 7-88 |
| Ammeter Removal/Installation | 7-25 | 7-90 |
| Speedometer/Odometer Removal/Installation | 7-26 | 7-92 |
| Tachometer/Hourmeter Removal/Installation | 7-27 | 7-93 |
| System Buzzer Removal/Installation | 7-28 | 7-94 |
| Junction Block Removal/Installation | 7-29 | 7-95 |
| Turn Indicator Light Assembly Removal/Installation | 7-30 | 7-96 |
| Warning Indicator Light Assembly Removal/Installation | 7-31 | 7-98 |
| High Beam Indicator Light Assembly Removal/Installation | 7-32 | 7-100 |
| Ignition Relay Removal/Installation | 7-33 | 7-101 |
| Horn Relay Removal/Installation | 7-34 | 7-103 |
| Magnetic Switch Removal/Installation | 7-35 | 7-105 |
| Instrument Panel Receptacle Removal/Installation | 7-36 | 7-109 |
| ENGINE START Switch Removal/Installation | 7-37 | 7-111 |
| ENGINE STOP Switch Removal/Installation | 7-38 | 7-113 |
| Side Panel Switches Removal/Installation | 7-39 | 7-114 |
| Engine Brake Indicator Light Removal/Installation | 7-40 | 7-116 |
| Main Light Switch Removal/Installation | 7-41 | 7-117 |
| Heater Fan Switch Removal/Installation | 7-42 | 7-118 |
| Circuit Breaker (Center Console) Removal/Installation | 7-43 | 7-119 |
| Circuit Breaker Rack and Panel Removal/Installation | 7-44 | 7-122 |
| Instrument Panel Harness Removal/Installation | 7-45 | 7-125 |
| Brake Treadle Valve Stoplight Switch Removal/Installation | 7-46 | 7-139 |
| Main Junction Box Assembly Removal/Installation (M978) | 7-47 | 7-142 |
| Auxiliary Pump Junction Box Assembly Removal/Installation (M978) | 7-48 | 7-150 |
| Control Junction Box Removal/Installation (M978) | 7-49 | 7-157 |
| Turn Signal Switch Removal/Installation | 7-50 | 7-166 |
| Flasher Relay Removal/Installation | 7-51 | 7-169 |
| Deleted | 7-52 | |

| Contents | Para | Page |
|---|-------------|-------------|
| Control Box Removal/Repair/Installation (M984E1) | 7-52.1 | 7-171 |
| Tanker Conduit Tubing Removal/Installation | 7-53 | 7-181 |
| Outrigger Switch Box Removal/Installation (M984) | 7-54 | 7-185 |
| Removable Work Lamps and Bracket Removal/Installation (M984) | 7-54.1 | 7-188 |
| Removable Warning Light Repair | 7-55 | 7-193 |
| ■ Removable Warning Light Repair (Model C) | 7-55.1 | 7-198.6 |
| Optic Ribbon Assembly Removal/Installation | 7-56 | 7-200 |
| Headlight Adjustment | 7-57 | 7-204 |
| Headlight Removal/Installation | 7-58 | 7-207 |
| Headlight Assembly Removal/Installation | 7-59 | 7-209 |
| Front and Rear Composite Light Lamp Removal/Installation | 7-60 | 7-215 |
| Front Composite Light Assembly Removal/Installation | 7-61 | 7-217 |
| Composite Taillight Assembly Removal/Installation | 7-62 | 7-219 |
| ■ High-Mount Stop Lamp Assembly Removal/Installation (M978) | 7-62.1 | 7-222.1 |
| Front Cab Clearance Lamp Removal/Installation | 7-63 | 7-223 |
| ■ Front Cab Clearance Light/LED Assembly and Mounting Bracket Removal/Installation Step, Side and Rear Clearance, and Side Turn Light Removal/Installation | 7-64 | 7-225 |
| ■ Side and Rear Clearance Lights/LED Removal/Installation (M977, M983, M984, M985) . | 7-65 | 7-229 |
| Side and Rear Clearance Light Brackets Removal/Installation (M977, M984, M985) | 7-66 | 7-230 |
| Rear Side Clearance Marker Lights Removal/Installation (M984E1) | 7-67 | 7-232 |
| Rear Clearance Marker Lights and Bracket Removal/Installation (M984E1) | 7-67.1 | 7-237 |
| Blackout Light Assembly Removal/Installation | 7-67.2 | 7-239 |
| Blackout Light Lamp Removal/Installation | 7-68 | 7-241 |
| Domelight Assembly Removal/Installation | 7-69 | 7-242 |
| Work Lamps Removal/Installation (M983) | 7-70 | 7-243 |
| Work Lamps and Bracket Removal/Installation (M984) | 7-71 | 7-245 |
| Fixed Work Lamps Removal/Installation (M984E1) | 7-72 | 7-250 |
| Work Lamps Repair (M983, M984) | 7-72.1 | 7-257 |
| Beacon Light Assembly Removal/Repair/Installation (M984E1) | 7-73 | 7-260 |
| Beacon Light support Brackets Removal/Installation (M984E1) | 7-73.1 | 7-269 |
| Tow Light Assembly Repair (M984E1) | 7-73.2 | 7-271 |
| Red and Amber Marker Lights Removal/Installation (M978) | 7-73.3 | 7-272 |
| Pump Module Clearance Lights Removal/Installation (M978) | 7-74 | 7-277 |
| Pump Module Compartment Lights Removal/Installation (M978) | 7-75 | 7-279 |
| Ether Starting Aid Thermostat Removal/Installation | 7-76 | 7-282 |
| Water Temperature Sending Unit and Alarmstat Removal/Installation | 7-77 | 7-286 |
| Oil Pressure Sending Unit Removal/Installation | 7-78 | 7-288 |
| Fuel Level Sending Unit Removal/Installation | 7-79 | 7-290 |
| Speedometer Sending Unit Removal/Installation | 7-80 | 7-292 |
| Hour Meter Oil Pressure Switch Removal/Installation | 7-81 | 7-294 |
| Oil Manifold Hose Removal/Installation | 7-82 | 7-296 |
| Oil Pressure Switch Removal/Installation | 7-83 | 7-298 |
| Transmission Oil Temperature Switch Removal/Installation | 7-84 | 7-301 |
| TLI TANK LEVEL INDICATOR Gage and Bracket Removal/Installation (M978) (2 Studs on Back of Gage) | 7-85 | 7-303 |
| TLI TANK LEVEL INDICATOR Gage and Bracket Removal/Installation (M978) (5 Studs on Back of Gage) | 7-86 | 7-305 |
| Tank Level Indicator Adjuster Removal/Installation/Adjustment (M978) | 7-86.1 | 7-310.1 |
| Fuel Level Sensor Removal/Installation (M978) | 7-87 | 7-310.6 |
| Electric Horn Removal/Installation | 7-88 | 7-319 |
| Batteries, Terminals, and Cables Removal/Installation | 7-89 | 7-321 |
| Negative Battery Cables Disconnect/Connect | 7-90 | 7-324 |
| Battery Box and NATO Connector Removal/Repair/Installation | 7-91 | 7-333 |
| NATO Slave Receptacle and Box Removal/Repair/Installation | 7-92 | 7-335 |
| Resistor Module Removal/Installation | 7-92.1 | 7-345 |
| Starter Relay Removal/Installation | 7-93 | 7-349 |
| PTO Indicator Light Assembly, Switch, and Harness Removal/Installation | 7-94 | 7-353 |
| Crane Outrigger Extended Light Assembly Removal/Installation (M983, M984, M985E1) | 7-95 | 7-353 |
| | 7-96 | 7-357 |

| | | |
|--|-------|-------|
| Contents | Para | Page |
| Neutral Interlock Switch Sender Unit Removal/Installation | 7-97 | 7-359 |
| Tachometer Sending Unit Removal/Installation | 7-98 | 7-361 |
| Traction Control Indicator Light Assembly Removal/Installation | 7-99 | 7-362 |
| Ether Start Switch Removal/Installation. | 7-100 | 7-364 |
| Horn Switch Contact Roller Removal/Installation | 7-101 | 7-366 |
| Dimmer Switch Removal/Installation | 7-102 | 7-370 |
| Trailer Electrical Connector Removal/Installation (M983). | 7-103 | 7-371 |
| Fuel Restriction Sensor Removal/Installation. | 7-104 | 7-374 |
| Clearance Light Wiring Harness Removal/Installation (M977, M985) | 7-105 | 7-377 |

Section I. INTRODUCTION

7-1. GENERAL. This chapter contains maintenance instructions for replacing, installing, adjusting, removing, and testing the electrical system components authorized by the Maintenance Allocation Chart (MAC) at the organizational maintenance level.

Section II. ALTERNATOR AND VOLTAGE REGULATOR

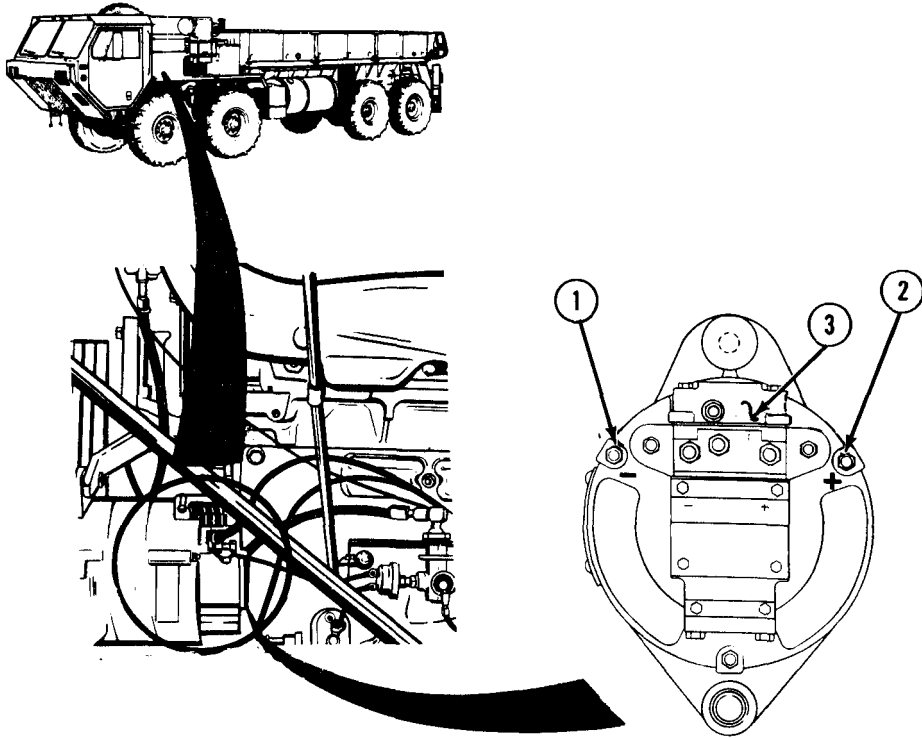
Electrical System Maintenance Instructions

| | | | | | | | | | | | | | | | | | | | | | | | | | |
|--|--|---------------|----------------------------|-----|--|-----------------------|------------------------------------|---------------------------------|-------------------------------------|----------------------|---|------|----------------------------------|-----------------|---|------|------|---------------------------|------------------------------------|---------------------------------------|------|-------------------|--|------|--|
| 7-2. ALTERNATOR TESTING. | | | | | | | | | | | | | | | | | | | | | | | | | |
| <p>This task covers:</p> <ul style="list-style-type: none"> a. Alternator Testing b. Follow-on Maintenance | | | | | | | | | | | | | | | | | | | | | | | | | |
| <p>INITIAL SETUP</p> <table border="0" style="width: 100%;"> <tr> <td style="width: 50%;"><i>Models</i></td> <td style="width: 50%;"><i>Equipment Condition</i></td> </tr> <tr> <td>All</td> <td><i>TM or Para</i> <i>Condition Description</i></td> </tr> <tr> <td><i>Test Equipment</i></td> <td>TM 9-2320-279-10 Parking brake on.</td> </tr> <tr> <td>Multimeter NSN 6625-01-139-2512</td> <td>TM 9-2320-279-10 Engine cover open.</td> </tr> <tr> <td><i>Special Tools</i></td> <td>TM 9-2320-279-10 Engine side panel removed.</td> </tr> <tr> <td>None</td> <td>TM 9-2320-279-10 Engine running.</td> </tr> <tr> <td><i>Supplies</i></td> <td><i>Special Environmental Conditions</i></td> </tr> <tr> <td>None</td> <td>None</td> </tr> <tr> <td><i>Personnel Required</i></td> <td><i>General Safety Instructions</i></td> </tr> <tr> <td>MOS 63S, Heavy wheel vehicle mechanic</td> <td>None</td> </tr> <tr> <td><i>References</i></td> <td></td> </tr> <tr> <td>None</td> <td></td> </tr> </table> | | <i>Models</i> | <i>Equipment Condition</i> | All | <i>TM or Para</i> <i>Condition Description</i> | <i>Test Equipment</i> | TM 9-2320-279-10 Parking brake on. | Multimeter NSN 6625-01-139-2512 | TM 9-2320-279-10 Engine cover open. | <i>Special Tools</i> | TM 9-2320-279-10 Engine side panel removed. | None | TM 9-2320-279-10 Engine running. | <i>Supplies</i> | <i>Special Environmental Conditions</i> | None | None | <i>Personnel Required</i> | <i>General Safety Instructions</i> | MOS 63S, Heavy wheel vehicle mechanic | None | <i>References</i> | | None | |
| <i>Models</i> | <i>Equipment Condition</i> | | | | | | | | | | | | | | | | | | | | | | | | |
| All | <i>TM or Para</i> <i>Condition Description</i> | | | | | | | | | | | | | | | | | | | | | | | | |
| <i>Test Equipment</i> | TM 9-2320-279-10 Parking brake on. | | | | | | | | | | | | | | | | | | | | | | | | |
| Multimeter NSN 6625-01-139-2512 | TM 9-2320-279-10 Engine cover open. | | | | | | | | | | | | | | | | | | | | | | | | |
| <i>Special Tools</i> | TM 9-2320-279-10 Engine side panel removed. | | | | | | | | | | | | | | | | | | | | | | | | |
| None | TM 9-2320-279-10 Engine running. | | | | | | | | | | | | | | | | | | | | | | | | |
| <i>Supplies</i> | <i>Special Environmental Conditions</i> | | | | | | | | | | | | | | | | | | | | | | | | |
| None | None | | | | | | | | | | | | | | | | | | | | | | | | |
| <i>Personnel Required</i> | <i>General Safety Instructions</i> | | | | | | | | | | | | | | | | | | | | | | | | |
| MOS 63S, Heavy wheel vehicle mechanic | None | | | | | | | | | | | | | | | | | | | | | | | | |
| <i>References</i> | | | | | | | | | | | | | | | | | | | | | | | | | |
| None | | | | | | | | | | | | | | | | | | | | | | | | | |

Electrical System Maintenance Instructions (Cont)

7-2 ALTERNATOR TESTING (CONT).

a. Alternator Testing.



NOTE

- If truck is equipped with 65, 100, or 130 amp alternator, perform steps (1) through (4).

- (1) Connect voltmeter to negative terminal (1) and positive terminal (2). Meter should be between 26 and 28 volts at 1200 to 1500 rpm.
- (2) If output is not between 26 and 28 volts, adjust regulator (3) (para 7-6).
- (3) If output is still not between 26 and 28 volts, replace regulator (3) (para 7-5).
- (4) If output is still under 26 volts, replace alternator (para 7-3).

b. Follow-on Maintenance.

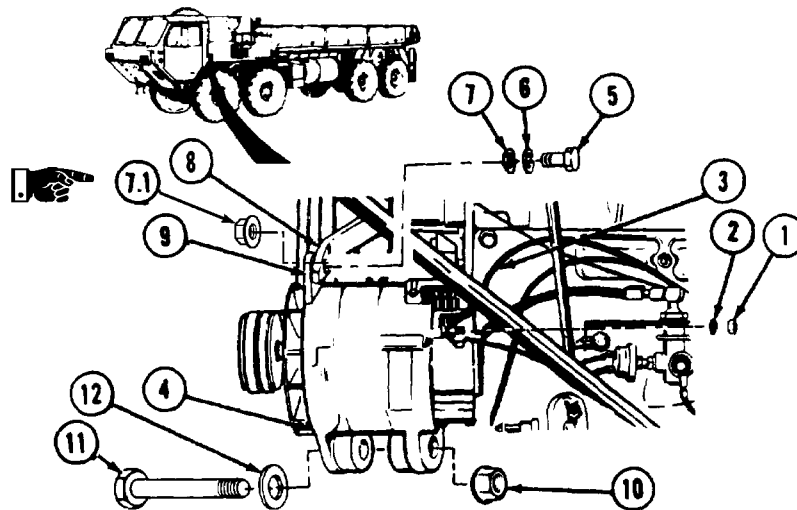
- (1) Shut off engine (TM 9-2320-279-10).
- (2) Install engine side panel (TM 9-2320-279-10).
- (3) Close engine cover (TM 9-2320-279-10).

END OF TASK

Electrical System Maintenance Instructions (Cont).

| 7-3. ALTERNATOR AND PULLEY REMOVAL/INSTALLATION. | | |
|--|---|------------------------------|
| This task covers: | | |
| a. Removal | c. Follow-on Maintenance | |
| b. Installation | | |
| INITIAL SETUP | | |
| <i>Models</i> | <i>References</i> | |
| All | None | |
| <i>Test Equipment</i> | <i>Equipment Condition</i> | |
| None | <i>TM or Para</i> | <i>Condition Description</i> |
| <i>Special Tools</i> | Para 7-91 | Batteries disconnected. |
| None | Para 6-15 | Alternator belts removed. |
| <i>Supplies</i> | <i>Special Environmental Conditions</i> | |
| Tags, identification, Item 48, Appendix C | None | |
| Sealant, RTV200 Electrical, Item 45.05, Appendix C | <i>General Safety Instructions</i> | |
| <i>Personnel Required</i> | None | |
| MOS 63S, Heavy wheel vehicle mechanic | | |

a. Removal.



NOTE

Tag and mark all wires before removal.

- (1) Remove three nuts (1), lockwashers (2), and wires (3) from alternator (4).

NOTE

- If truck is equipped with 65 amp alternator, perform step (2).
- If truck is equipped with 130 amp alternator, perform step (2.1).
- (2) Remove adjusting screw (5), lockwasher (6), and washer (7) from brace (8) and mounting ear (9).
- (2.1) Remove adjusting screw (5), lockwasher (6), washer (7), and nut (7.1) from brace (8) and mounting ear (9).
- (3) Remove nut (10), mounting screw (11), and washer (12).
- (4) Remove alternator (4).

Electrical System Maintenance Instructions (Cont)

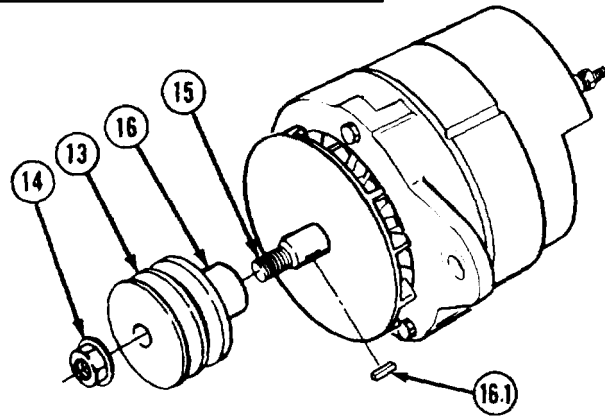
7-3. ALTERNATOR AND PULLEY REMOVAL/INSTALLATION (CONT).

- (5) Clamp pulley (13) in vise with soft jaws.
- (6) Loosen locknut (14) until shaft (15) turns.
- (7) Using lockjaw pliers, hold inside flange (16) of pulley (13) and remove locknut (14).

NOTE

There are two types of alternator pulleys. Model A has no key, while Model B includes one.

- (8) Remove pulley (13) from vise and remove pulley and key (16.1) from shaft (15).

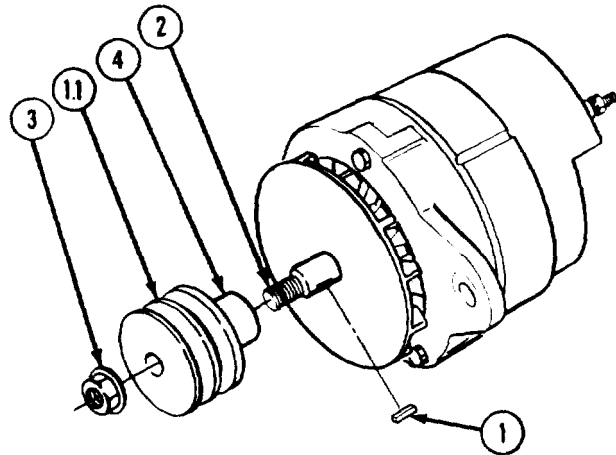


b. Installation.

NOTE

There are two types of alternator pulleys. Model A has no key, while Model B includes one.

- (1) Install key (1) and pulley (1.1) on shaft (2).
- (2) Clamp pulley (1.1) in vise with soft jaws.
- (3) Install locknut (3) on shaft (2) and tighten until shaft (2) begins to turn.
- (4) Using lockjaw pliers, hold inside flange (4) of pulley (1.1) and tighten locknut (3) to 70 to 85 lb-ft (95 to 115 N•m).
- (5) Remove lockjaw pliers and re-torque locknut (3).

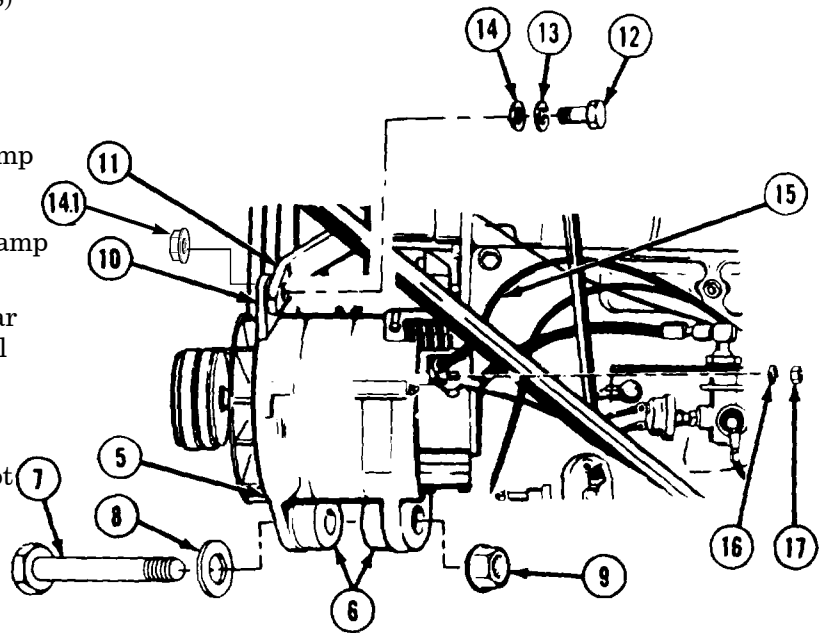


Electrical System Maintenance Instructions (Cont)

- (6) Position alternator (5) on mounting brackets (6). Install mounting screw (7), washer (8) and nut (9). Do not tighten nut.

NOTE

- If truck is equipped with 65 amp alternator, perform step (7).
 - If truck is equipped with 130 amp alternator, perform step (7.1).
- (7) Place rear side of mounting ear (10) against brace (11). Install adjusting screw (12) with lockwasher (13) and washer (14) through brace (11) and into mounting ear (10). Do not tighten screw (12).
- (7.1) Place rear side of mounting ear (10) against brace (11). Install adjusting screw (12) with lockwasher (13), washer (14), and nut (14.1) through brace (11) and into mounting ear (10). Do not tighten screw (12).



WARNING

Adhesives, solvents, and sealing compounds can burn easily, can give off harmful vapors, and are harmful to skin and clothing. To avoid injury or death, keep away from open fire and use in well-ventilated area. If adhesive, solvent, or sealing compound gets on skin or clothing, wash immediately with soap and water.

NOTE

Apply electrical sealant to exposed wire connectors after installing connectors.

- (8) Install three wires (15), lockwashers (16), and nuts (17).

c. Follow-on Maintenance.

- (1) Install alternator belts (para 6-15).
- (2) Connect batteries (para 7-91).
- (3) Test alternator (para 7-2).

END OF TASK

Electrical System Maintenance Instructions (Cont)

7-4. ALTERNATOR SUPPORT AND ADJUSTING STRAP REMOVAL/INSTALLATION.

This task covers:

- a. Removal
- b. Installation
- c. Follow-on Maintenance

INITIAL SETUP

Models

All

Test Equipment

None

Special Tools

None

Supplies

None

Personnel Required

MOS 63S, Heavy wheel vehicle mechanic

References

None

Equipment Condition

TM or Para

Para 7-3

Para 6-12

Condition Description

Alternator removed.

Fan clutch removed.

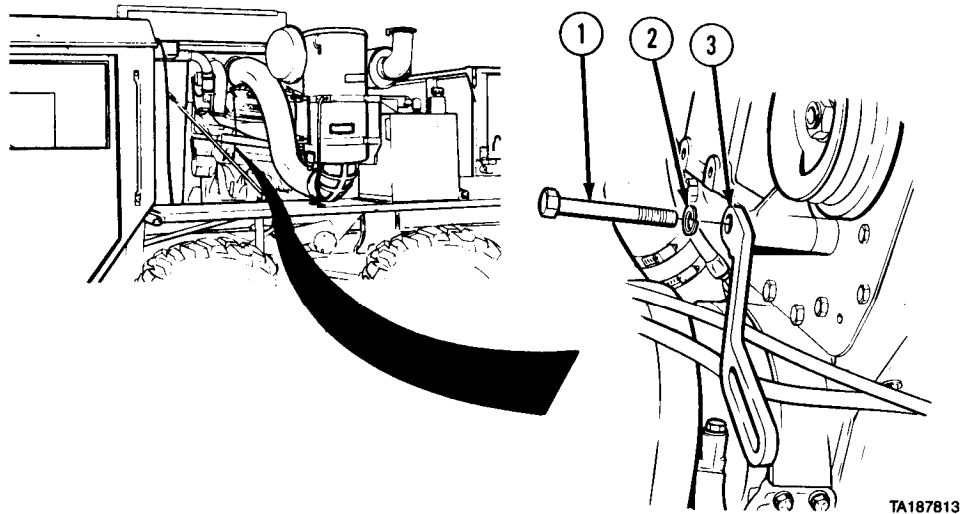
Special Environmental Conditions

None

General Safety Instructions

None

a. Removal.

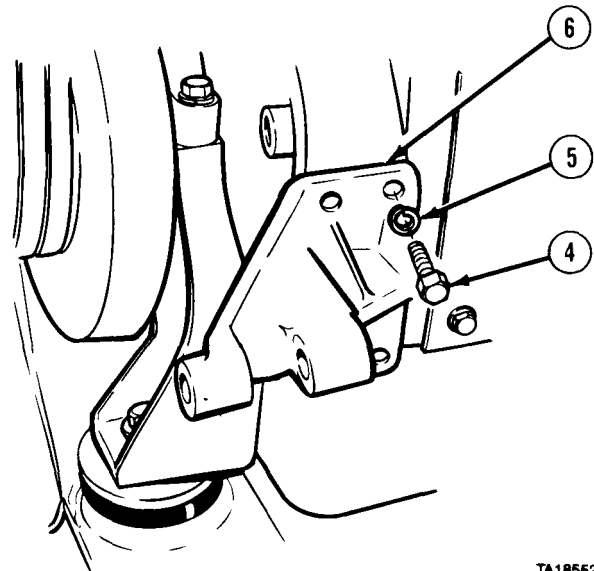


(1) Remove screw (1), lockwasher (2), and adjusting strap (3).

Electrical System Maintenance Instructions (Cont)

7-4. ALTERNATOR SUPPORT AND ADJUSTING STRAP REMOVAL/INSTALLATION (CONT).

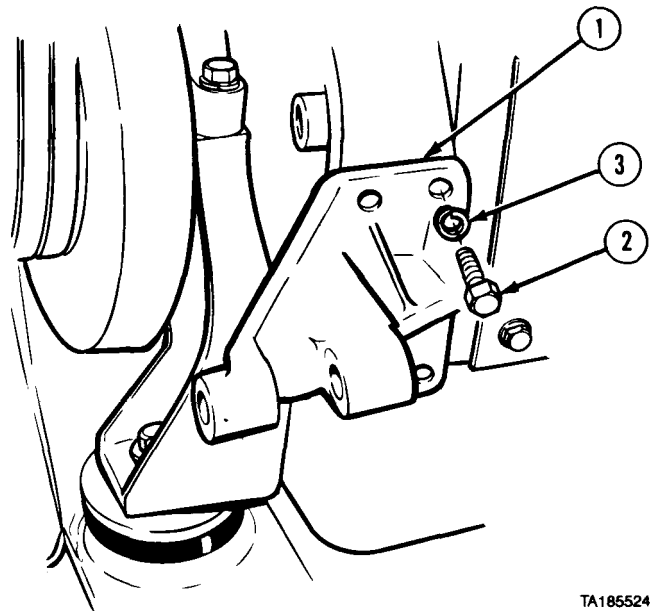
(2) Remove four screws (4), lockwashers (5), and support (6).



TA185523

b. Installation.

(1) Install support (1) with four screws (2) and lockwasher (3).



TA185524

Electrical System Maintenance Instructions (Cont)

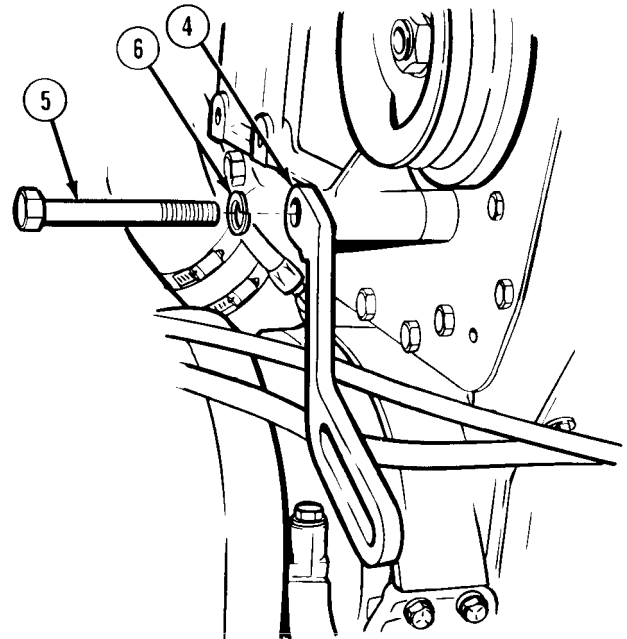
NOTE

Do not tighten screw until alternator is installed.

- (2) Install adjusting strap (4) with screw (5) and lockwasher (6).

c. Follow-on Maintenance.

- (1) Install fan clutch (para 6-12).
- (2) Install alternator (para 7-3).
- (3) Adjust fan belts (para 6-16).
- (4) Adjust alternator belts (para 6-14).



END OF TASK

| 7-5. VOLTAGE REGULATOR REMOVAL/INSTALLATION. | |
|--|---|
| This task covers: | |
| a. Removal | c. Follow-on Maintenance |
| b. Installation | |
| INITIAL SETUP | |
| <i>Models</i> All | <i>References</i> None |
| <i>Test Equipment</i> None | <i>Equipment Condition</i> |
| <i>Special Tools</i> None | <i>TM or Para</i> <i>Condition Description</i> |
| <i>Supplies</i> Sealant, RTV200 Electrical, Item 45.05, Appendix C | TM 9-2320-279-10 Engine cover open. |
| <i>Personnel Required</i> MOS 63S, Heavy wheel vehicle mechanic | TM 9-2320-279-10 Engine side panel removed. |
| | Para 7-91 Batteries disconnected. |
| | <i>Special Environmental Conditions</i> None |
| | <i>General Safety Instructions</i> None |

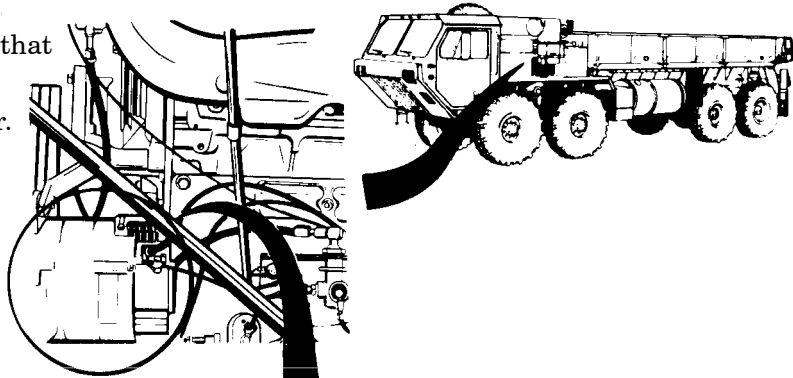
Electrical System Maintenance Instructions (Cont)

7-5. VOLTAGE REGULATOR REMOVAL/INSTALLATION (CONT).

NOTE

There are three models of alternator that may be installed on the vehicle.

- Model A is a 65 amp alternator.
- Model B is a 100 amp alternator.
- Model C is a 130 amp alternator. Repair of Model C is done at Direct Support.



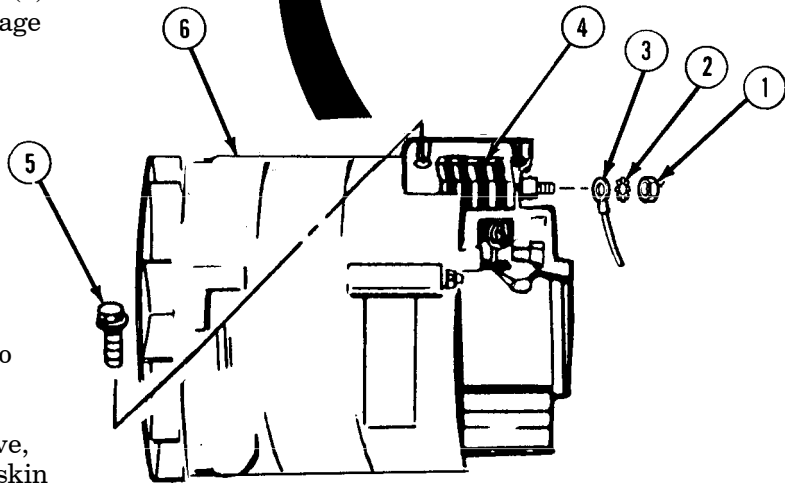
a. Removal.

- (1) Remove nut (1) and lockwasher (2) to disconnect wire (3) from voltage regulator (4).
- (2) Remove four screws (5) and voltage regulator (4) from alternator (6).

b. Installation.

WARNING

Adhesives, solvents, and sealing compounds can burn easily, can give off harmful vapors, and are harmful to skin and clothing. To avoid injury or death, keep away from open fire and use in well-ventilated area. If adhesive, solvent, or sealing compound gets on skin or clothing, wash immediately with soap and water.



NOTE

Apply electrical sealant to exposed wire connectors after installing connectors.

- (1) Position voltage regulator (4) on alternator (6) and attach with four screws (5).
- (2) Attach wire (3) with lockwasher (2) and nut (1).

c. Follow-on Maintenance.

- (1) Connect batteries (para 7-91).
- (2) Test alternator (para 7-2).
- (3) Install engine side panel (TM 9-2320-279-10).
- (4) Close engine cover (TM 9-2320-279-10).

END OF TASK

Electrical System Maintenance Instructions (Cont)

7-6. VOLTAGE REGULATOR ADJUSTMENT.

This task covers:

- a. Adjustment
- b. Follow-on Maintenance

INITIAL SETUP

Models
All

References
None

Test Equipment
None

Equipment Condition

Special Tools
None

TM or Para
Para 7-5

Condition Description
Voltage regulator removed.

Supplies
None

Special Environmental Conditions
None

Personnel Required
MOS 63S, Heavy wheel vehicle mechanic

General Safety Instructions
None

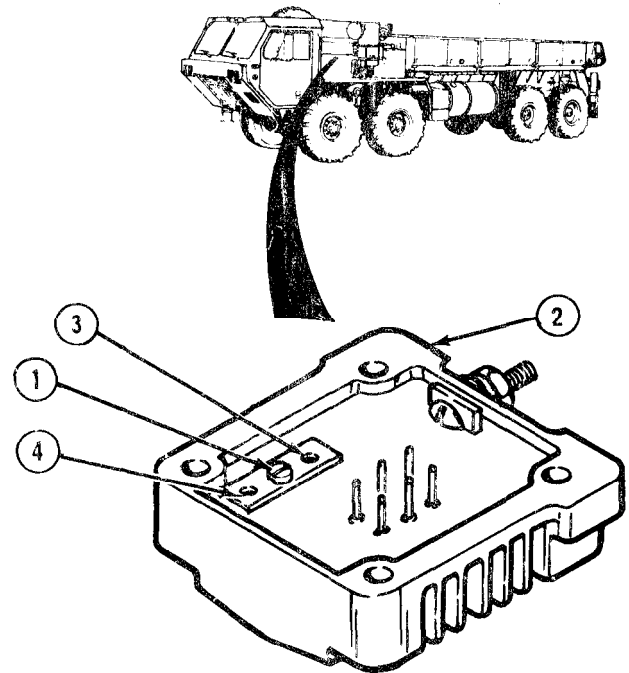
Electrical System Maintenance Instructions (Cont)

a. Adjustment.

- (1) If charging rate is too low, remove adjustment screw (1) from regulator (2).
- (2) Install adjustment screw (1) in high (HI) position hole (3).
- (3) If charging rate is too high, remove adjustment screw (1) from regulator (2).
- (4) Install adjustment screw (1) in low (LOW) position hole (4).

b. Follow-on Maintenance. Install voltage regulator (para 7-5) and check charging rate on AMPERES gage and BATTERY gage in cab.

END OF TASK



TA182001

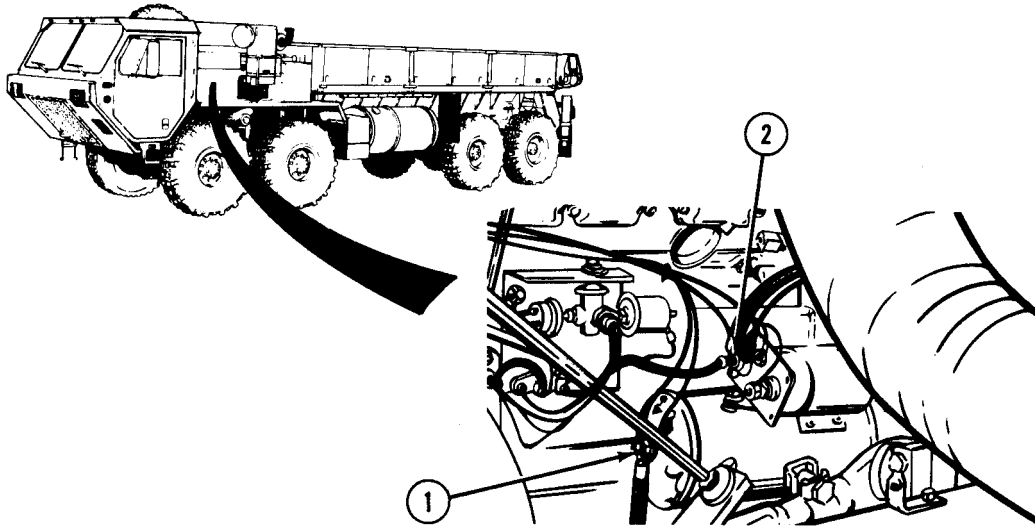
Section III. STARTER

| | |
|--|--|
| 7-7. STARTER MOTOR TESTING. | |
| This task covers: | |
| <ul style="list-style-type: none"> a. Testing b. Follow-on Maintenance | |
| INITIAL SETUP | |
| <i>Models</i> | <i>References</i> |
| All | None |
| <i>Test Equipment</i> | <i>Equipment Condition</i> |
| Multimeter NSN 6625-01-139-2512 | <i>TM or Para</i> <i>Condition Description</i> |
| <i>Special Tools</i> | TM 9-2320-279-10 Shut off engine. |
| None | TM 9-2320-279-10 Engine cover open. |
| <i>Supplies</i> | TM 9-2320-279-10 Engine side panel removed. |
| None | <i>Special Environmental Conditions</i> |
| <i>Personnel Required</i> | None |
| MOS 63S, Heavy wheel vehicle mechanic (2) | <i>General Safety Instructions</i> |
| | None |

Electrical System Maintenance Instructions (Cont)

7-7. STARTER MOTOR TESTING (CONT).

a. Testing.



TA182007

- (1) Measure voltage between ground (1) and positive terminal (2) of starter solenoid. If there is no voltage reading, refer to Electrical System Troubleshooting (para 2-15).
- (2) Turn ENGINE START switch to ON while holding ENGINE STOP switch engaged.
- (3) Soldier A cranks engine while Soldier B measures voltage between ground (1) and wire No. 45 on starter solenoid.
- (4) If there is at least 24 volts reading and starter does not crank engine, replace starter (para 7-8).

b. Follow-on Maintenance.

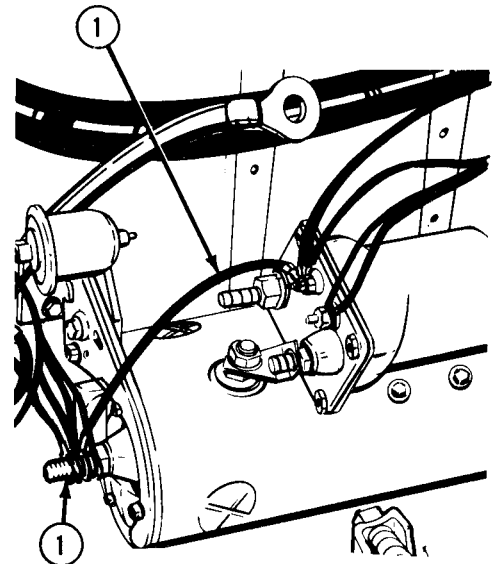
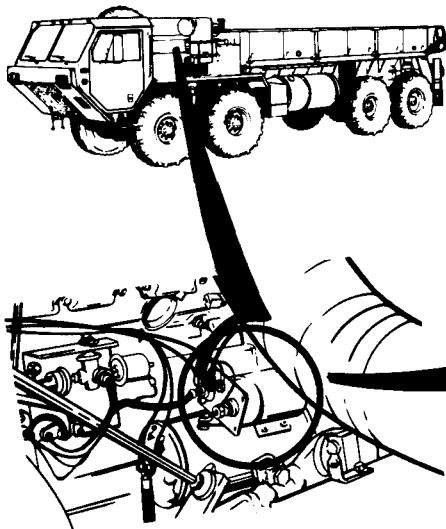
- (1) Install engine side panel (TM 9-2320-279-10).
- (2) Close engine cover (TM 9-2320-279-10).

END OF TASK

Electrical System Maintenance Instructions (Cont)

| | |
|---|--|
| 7-8. STARTER MOTOR REMOVAL/INSTALLATION. | |
| This task covers: | |
| a. Removal | c. Follow-on Maintenance |
| b. Installation | |
| INITIAL SETUP | |
| <i>Models</i> All | <i>References</i> None |
| <i>Test Equipment</i> None | <i>Equipment Condition</i> |
| <i>Special Tools</i> None | <i>TM or Para</i> <i>Condition Description</i> |
| <i>Supplies</i> Sealant, RTV200 Electrical, Item 45.05, Appendix C Tags, identification, Item 48, Appendix C | TM 9-2320-279-10 Engine cover open. TM 9-2320-279-10 Engine side panel removed. Para 7-91 Batteries disconnected. |
| <i>Personnel Required</i> MOS 63S, Heavy wheel vehicle mechanic (2) | <i>Special Environmental Conditions</i> None |
| | <i>General Safety Instructions</i> None |

a. Removal.



NOTE

Tag and mark starter cables and solenoid wires before disconnecting.

- (1) Disconnect starter motor cables and solenoid wires (1).

Electrical System Maintenance Instructions (Cont)

7-8. STARTER MOTOR REMOVAL/INSTALLATION (CONT).

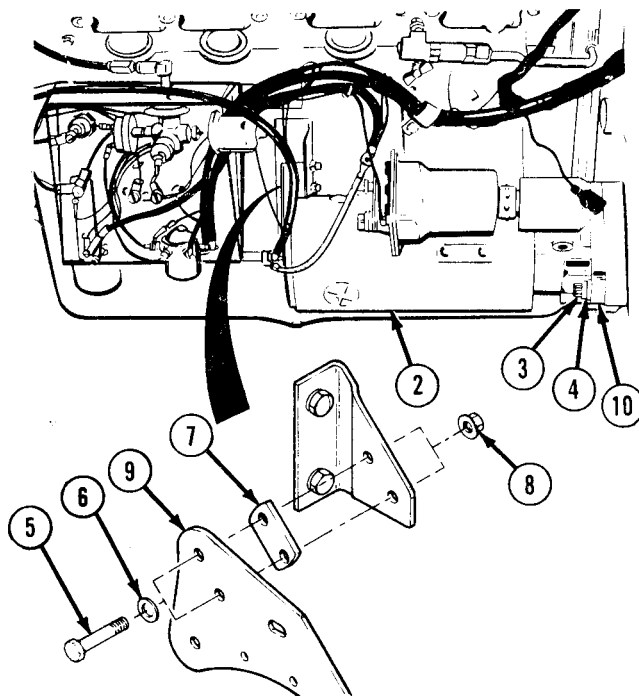
- (2) Support starter motor (2) and remove three screws (3) and lockwashers (4).
- (3) Remove two screws (5), washers (6), spacer (7), and locknuts (8) from starter end support bracket (9).
- (4) Pull starter motor (2) forward to remove it from flywheel housing (10).

b. Installation.

NOTE

Check flywheel ring gear for broken or damaged teeth before installing starter motor.

- (1) Insert starter motor (1) in flywheel housing (2).
- (2) Install two screws (3), washers (4), spacer (5), and locknuts (6) on starter end support bracket (7).
- (3) Secure starter motor (1) with three screws (8) and lockwashers (9).
- (4) Tighten locknuts (6).



WARNING

Adhesives, solvents, and sealing compounds can burn easily, can give off harmful vapors, and are harmful to skin and clothing. To avoid injury or death, keep away from open fire and use in well-ventilated area. If adhesive, solvent, or sealing compound gets on skin or clothing, wash immediately with soap and water.

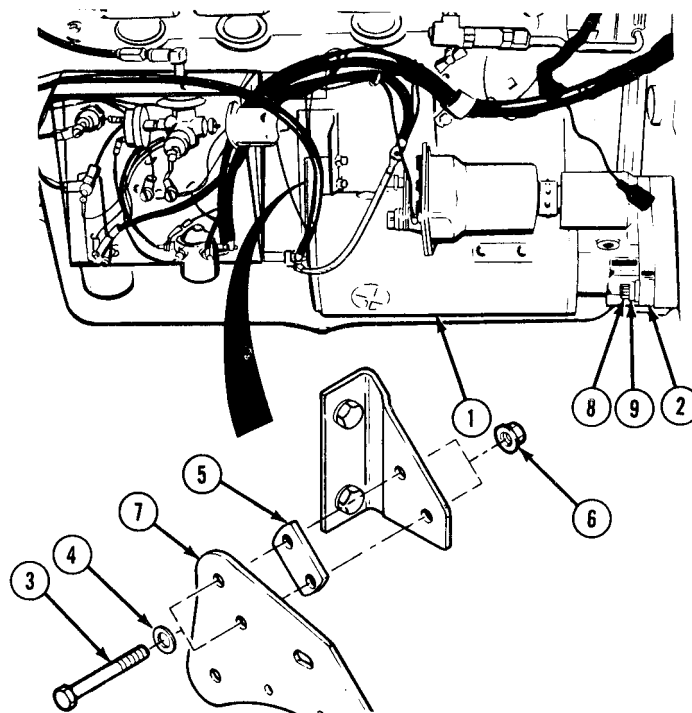
NOTE

Apply electrical sealant to exposed wire connectors after installing connectors.

- (5) Connect starter motor cables and solenoid wires.
- (6) Tighten screws (8).

c. Follow-on Maintenance.

- (1) Connect batteries (para 7-91).
- (2) Check starter motor operation (TM 9-2320-279-10).
- (3) Install engine side panel (TM 9-2320-279-10).
- (4) Close engine cover (TM 9-2320-279-10).



END OF TASK

Electrical System Maintenance Instructions (Contj

Section IV. ENGINE SAFETY CONTROLS

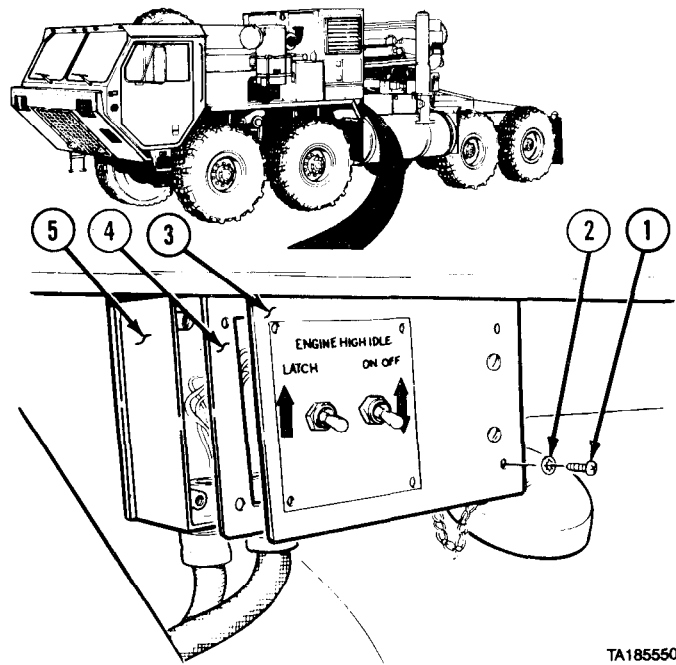
| | |
|---|---|
| 7-9. ENGINE SPEED CONTROL ASSEMBLY REPAIR (M983). | |
| This task covers: | |
| a. Disassembly b. Assembly | c. Follow-on Maintenance |
| INITIAL SETUP | |
| <i>Models</i> M983 | <i>References</i> None |
| <i>Test Equipment</i> None | <i>Equipment Condition</i> TM or Para Condition Description Para 7-91 Batteries disconnected. |
| <i>Special Tools</i> None | <i>Special Environmental Conditions</i> None |
| <i>Supplies</i> Connector, electrical, butt, Item 19, Appendix C Tags, identification, Item 48, Appendix C | <i>General Safety Instructions</i> None |
| <i>Personnel Required</i> MOS 63S, Heavy wheel vehicle mechanic | |

a. Disassembly.

NOTE

If engine high idle assembly is being removed in order to remove stowage box, go to step (19).

- (1) Remove six screws (1), lockwasher (2), cover (3), and gasket (4) from ENGINE HIGH IDLE box (5).



TA185550

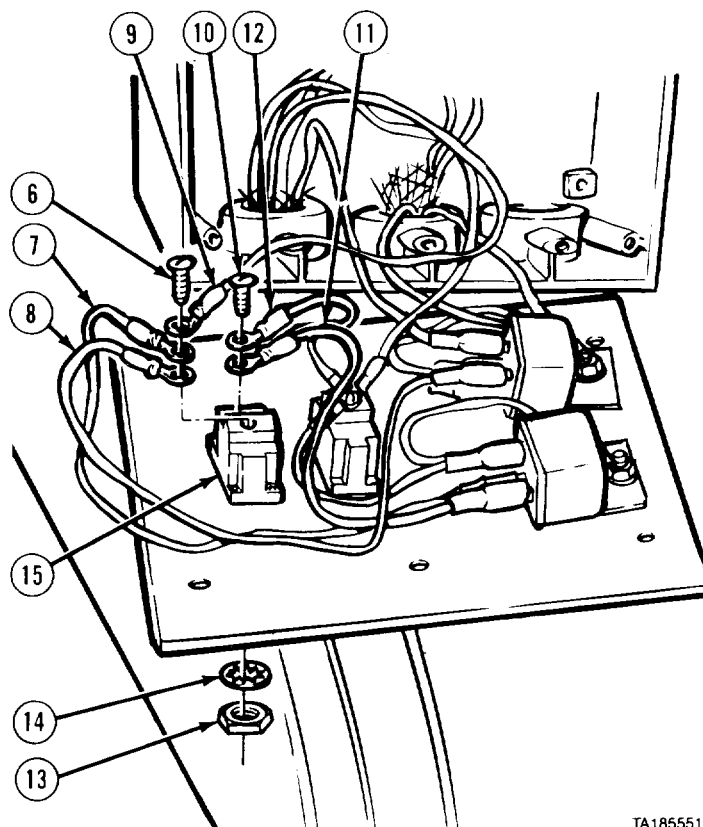
Electrical System Maintenance Instructions (Cont)

17-9. ENGINE SPEED CONTROL ASSEMBLY REPAIR (M983) (CONT).

NOTE

Tag and mark wires and switches before removing.

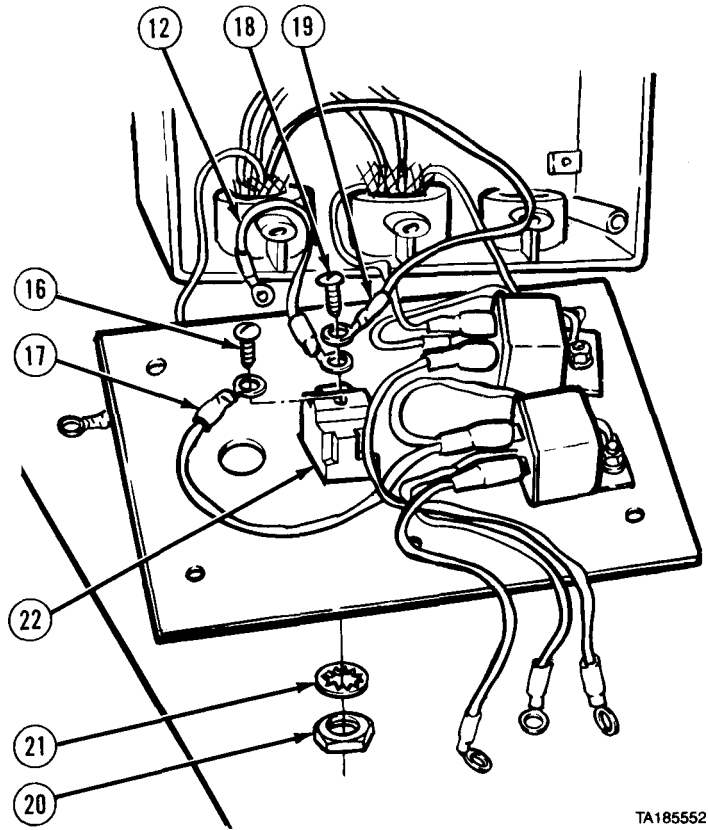
- (2) Remove screw (6) and three wires (7, 8, and 9).
- (3) Remove screw (10) and two wires (11 and 12).
- (4) Remove nut (13), lockwasher (14), and LATCH switch (15).



TA185551

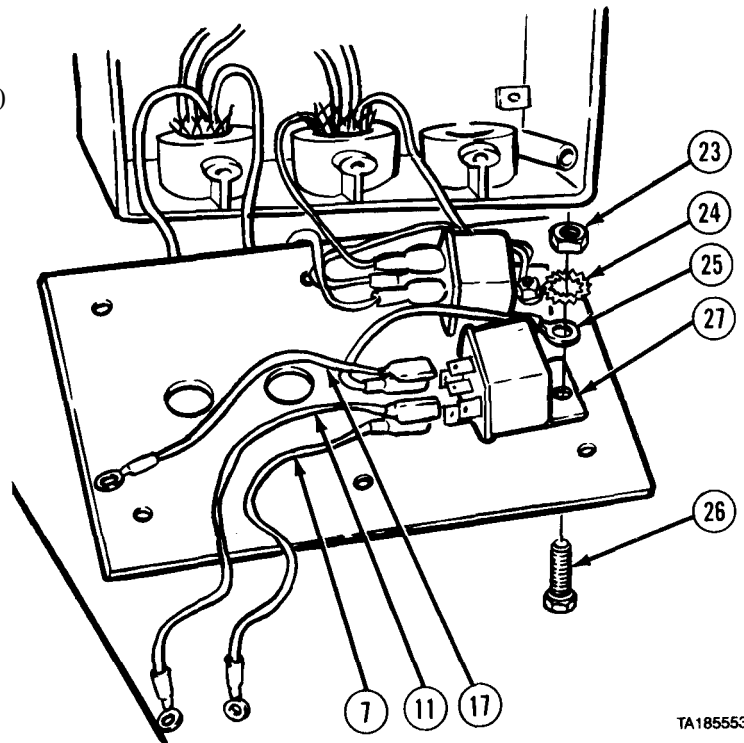
Electrical System Maintenance Instructions (Cont)

- (5) Remove screw (16) and wire (17).
- (6) Remove screw (18) and two wires (12 and 19).
- (7) Remove nut (20), lockwasher (21), and ON/OFF switch (22).



TA185552

- (8) Remove nut (23), lockwasher (24), wire (25), screw (26), and relay (27).
- (9) Remove four wires (25, 11, 17, and 7) from relay (27).

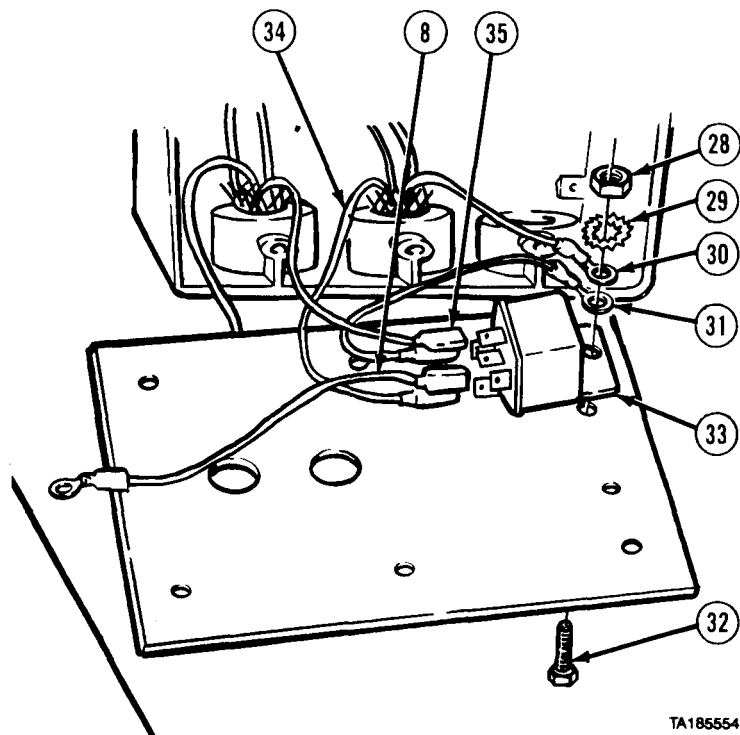


TA185553

Electrical System Maintenance Instructions (Cont)

7-9. ENGINE SPEED CONTROL ASSEMBLY REPAIR (M983) (CONT).

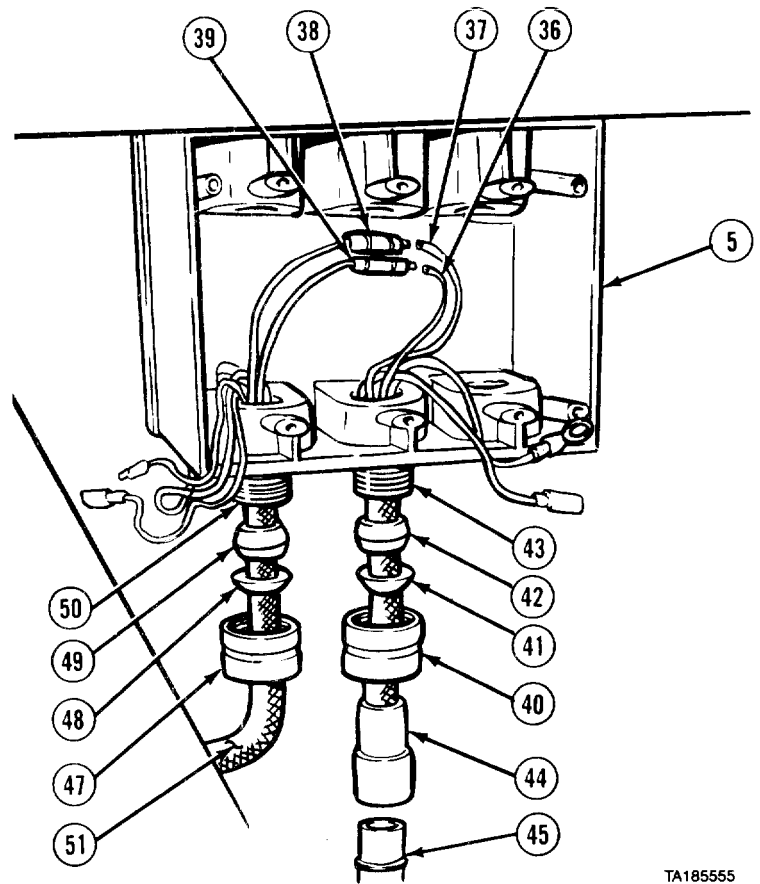
- (10) Remove nut (28), lockwasher (29), two wires (30 and 31), screw (32), and relay (33).
- (11) Remove four wires (31, 34, 35, and 8) from relay (33).



TA185554

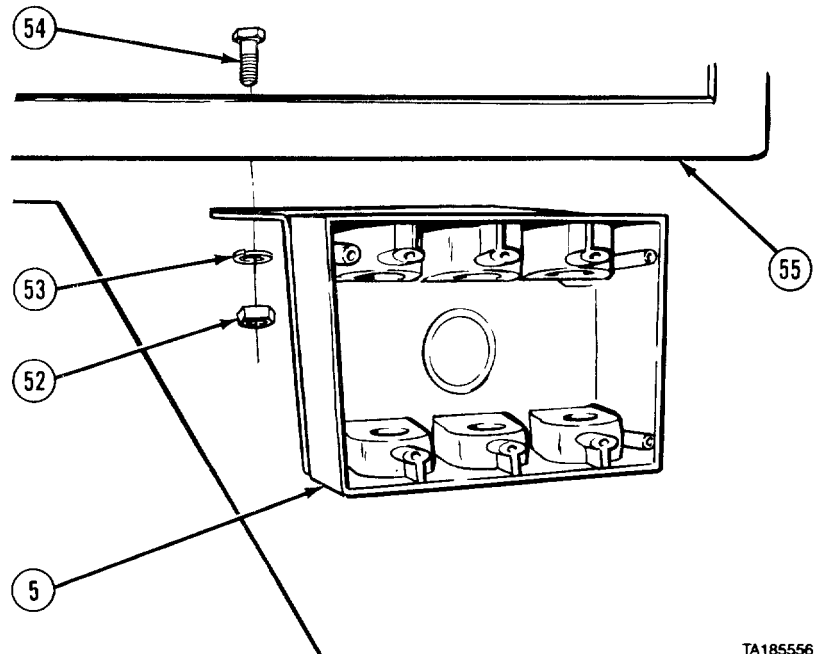
Electrical System Maintenance Instructions (Cont)

- (12) Cut wires (36 and 37) at connectors (38 and 39).
- (13) Remove cap (40), washer (41), and grommet (42) from fitting (43).
- (14) Remove crane wiring harness (44) from ENGINE HIGH IDLE box (5). Disconnect crane wiring harness at connector (45).
- (15) Remove grommet (42), washer (41), and cap (40) from wiring harness (44).
- (16) Remove cap (47), washer (48), and grommet (49) from fitting (50).
- (17) Remove high idle wiring harness (51) from ENGINE HIGH IDLE box (5). Remove grommet (49), washer (48), and cap (47) from high idle wiring harness.
- (18) Remove two fittings (43 and 50) from ENGINE HIGH IDLE box (5).



TA185555

- (19) Remove two nuts (52), lockwashers (53), screws (54), and ENGINE HIGH IDLE box (5) from stowage box (55).

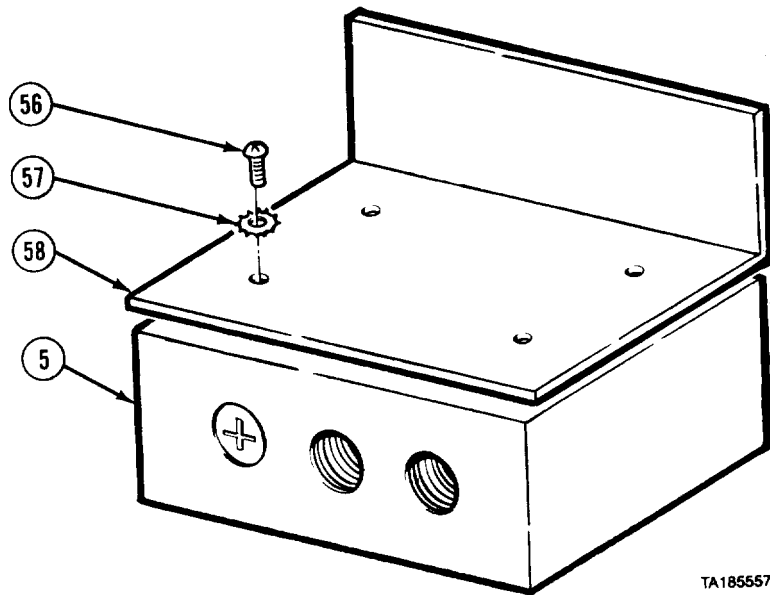


TA185556

Electrical System Maintenance Instructions (Cont)

17-9. ENGINE SPEED CONTROL ASSEMBLY REPAIR (M983) (CONT).

- (20) Remove four screws (56), lockwashers (57), and bracket (58) from ENGINE HIGH IDLE box (5).

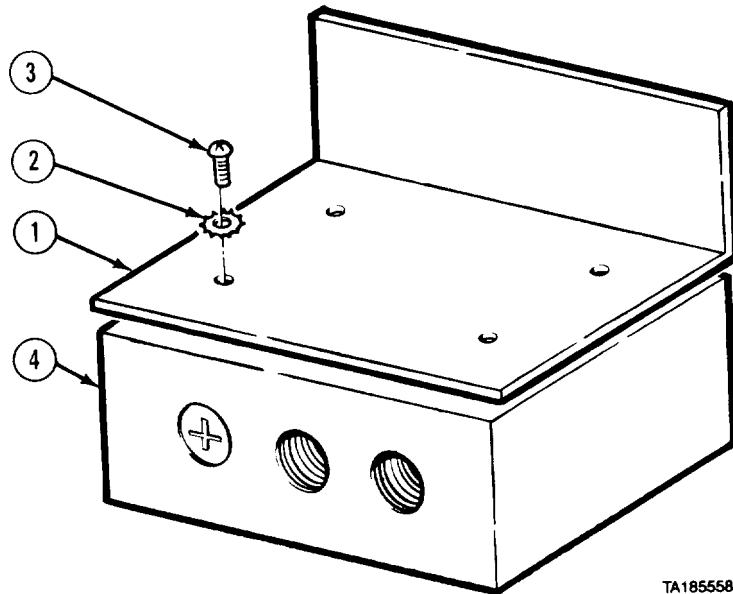


b. Assembly.

NOTE

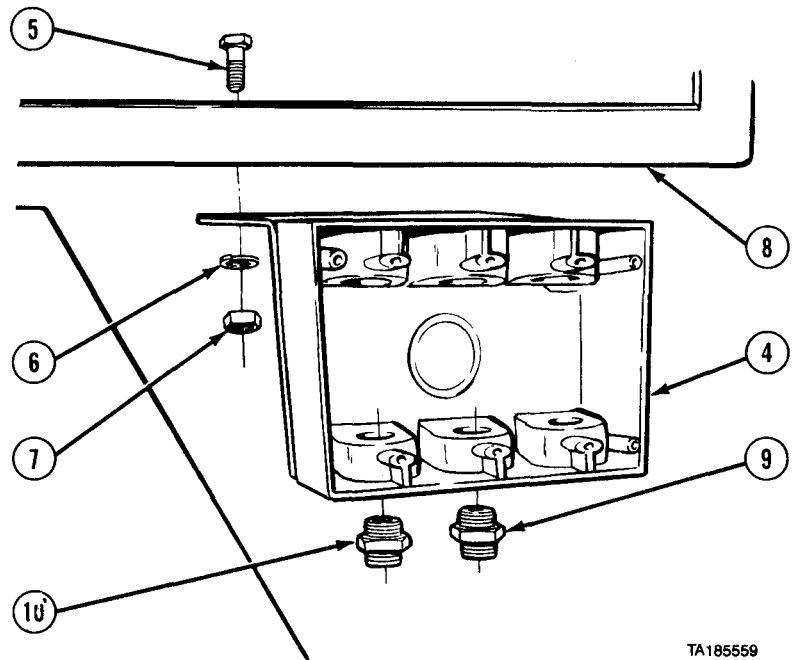
If high idle assembly was removed in order to remove stowage box, do step (2) only.

- (1) Install bracket (1), four lockwashers (2), and screws (3) on ENGINE HIGH IDLE box (4).



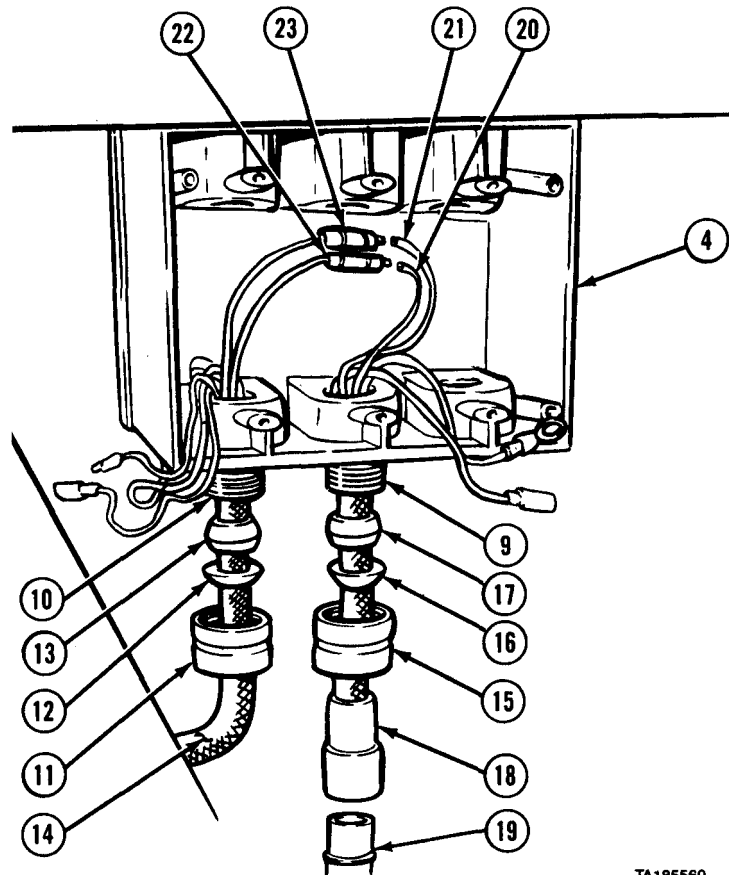
Electrical System Maintenance Instructions (Cont)

- (2) Install ENGINE HIGH IDLE box (4), two screws (5), lockwashers (6), and nuts (7) to stowage box (8).
- (3) Install two fittings (9 and 10) on ENGINE HIGH IDLE box (4).



TA185559

- (4) Install cap (11), washer (12), and grommet (13) on high idle wiring harness (14).
- (5) Install high idle warning harness (14) in ENGINE HIGH IDLE box (4). Install cap (11) on fitting (10).
- (6) Install cap (15), washer (16), and grommet (17) on crane wiring harness (18).
- (7) Install crane wiring harness (18) in ENGINE HIGH IDLE box (4). Install cap (15) on fitting (9). Connect connector (19).
- (8) Connect two wires (20 and 21) with butt connectors (22 and 23).

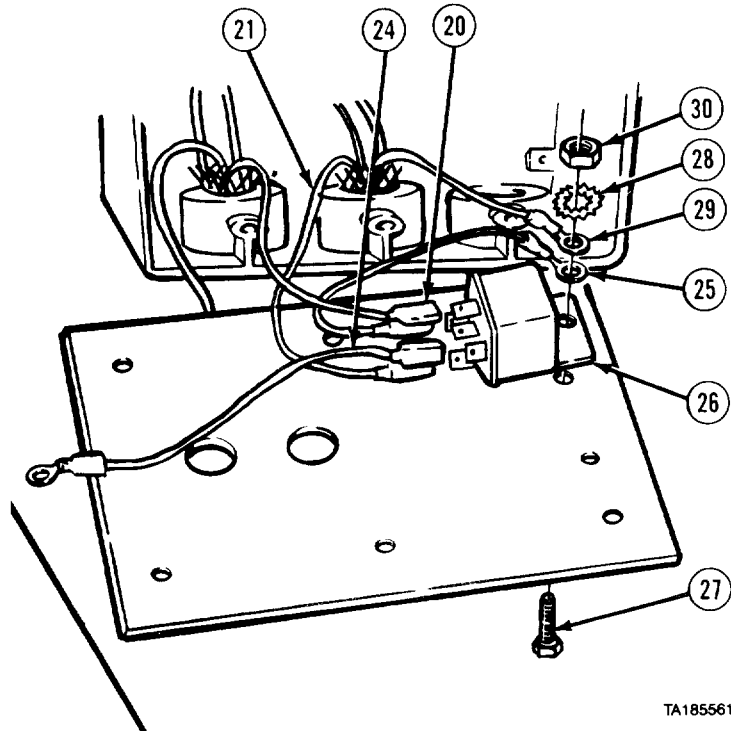


TA185560

Electrical System Maintenance Instructions (CONT).

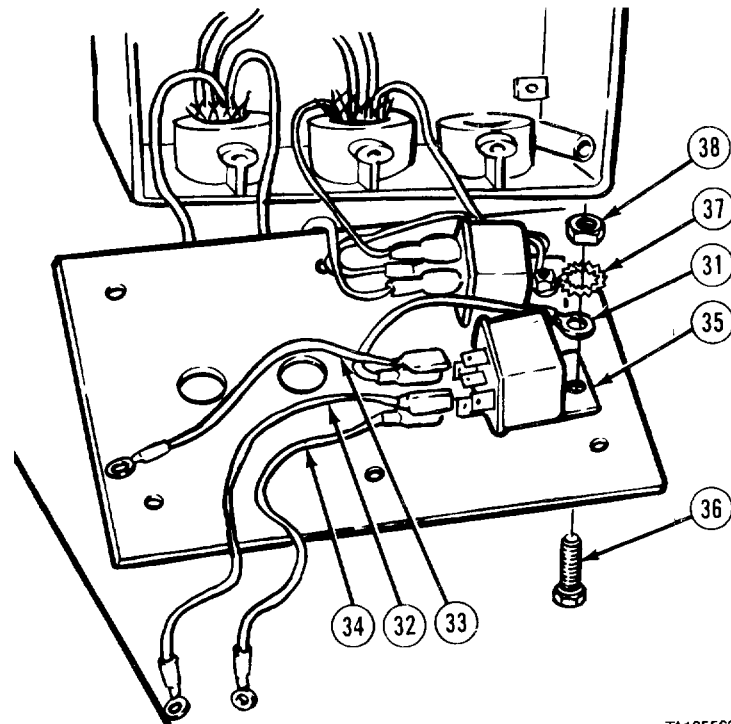
7-9 ENGINE SPEED CONTROL ASSEMBLY REPAIR (M983) (CONT).

- (9) Install four wires (24, 25, 20, and 21) on relay (26).
- (10) Install relay (26), screw (27), lockwashers (28), two wires (25 and 29), and nut (30).



TA185561

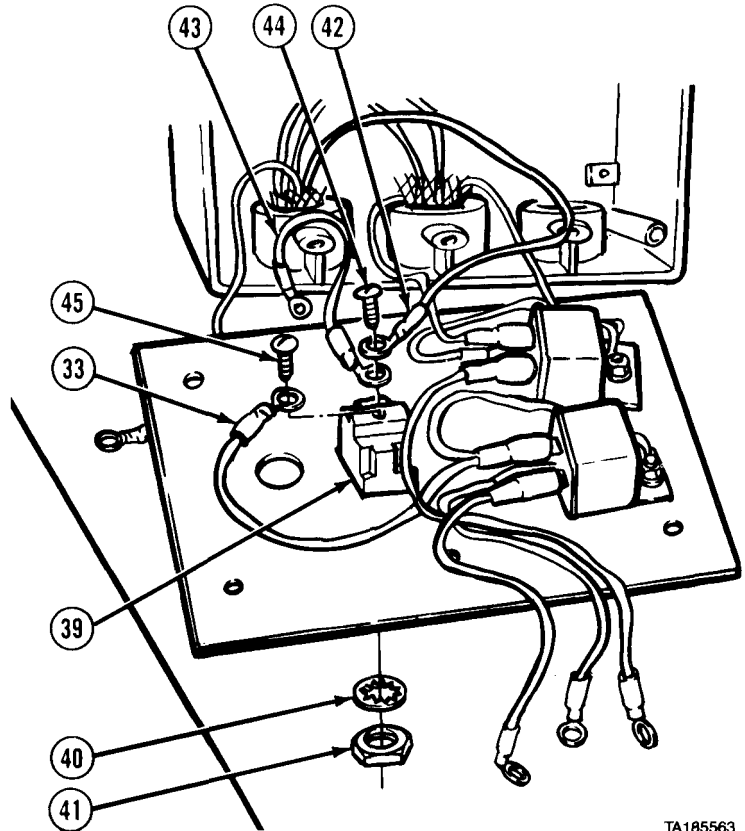
- (11) Install four wires (31, 32, 33, and 34) on relay (35).
- (12) Install relay (35), screw (36), lockwasher (37), wire (31), and nut (38).



TA185562

Electrical System Maintenance Instructions (Cont)

- (13) Install ON/OFF switch (39) with lockwasher (40) and nut (41).
- (14) Install two wires (42 and 43) and screw (44) on ON/OFF switch (39).
- (15) Install wire (33) and screw (45).

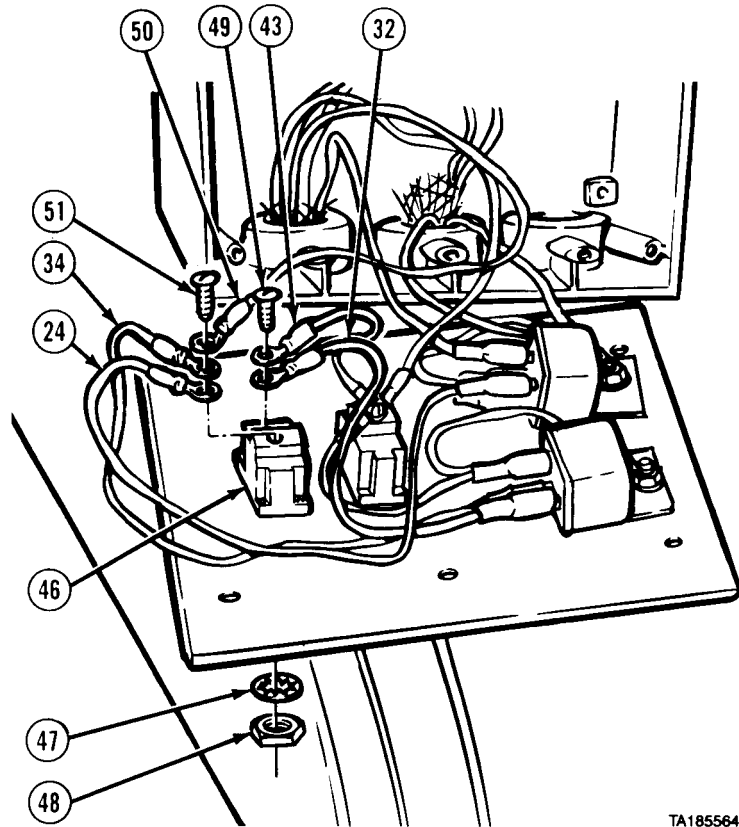


TA185563

Electrical System Maintenance Instructions (Cont)

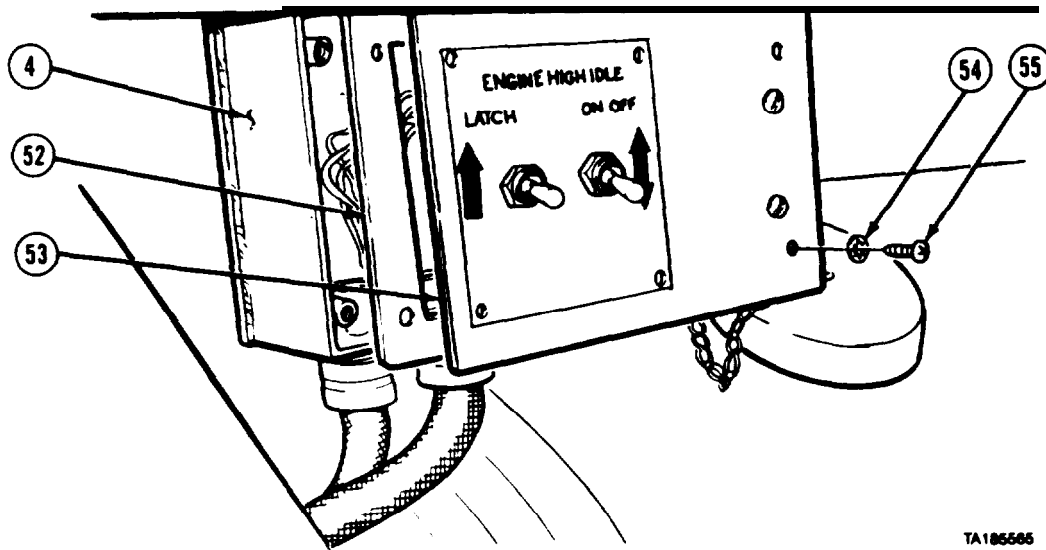
7-9. ENGINE SPEED CONTROL ASSEMBLY REPAIR (M983) (CONT).

- (16) Install LATCH switch (46) with lockwasher (47) and nut (48).
- (17) Install two wires (32 and 43) and screw (49) on LATCH switch (46).
- (18) Install three wires (34, 24, and 50) and screw (51).



TA185564

Electrical System Maintenance Instructions (Cont)



TA185585

(19) Install gasket (52) cover (53) six lockwashers (54) and screws (55) on ENGINE HIGH IDLE box (4).

c. Follow-on Maintenance.

- (1) Connect batteries (para 7-9 1).
- (2) Check operation of LATCH and ON/OFF switches (TM 9-2320-279-10).

END OF TASK

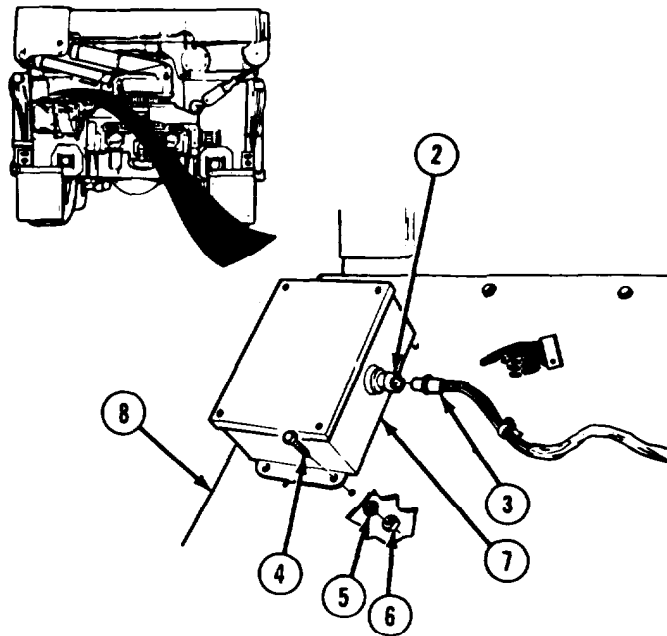
| | |
|--|---|
| 7-10. ENGINE HIGH IDLE BOX REMOVAL/REPAIR/INSTALLATION (M977, M985). | |
| This task covers: | |
| a. Removal | d. Installation |
| b. Disassembly | e. Follow-on Maintenance |
| c. Assembly | |
| INITIAL SETUP | |
| Models M977, M985 | References None |
| Test Equipment None | Equipment Condition |
| Special Tools None | TM or Para Condition Description |
| Supplies Connector, electrical, butt, Item 19, Appendix C 'lags, identification, Item 48, Appendix C | Para 7-91 Disconnect batteries. |
| | Special Environmental Conditions None |
| | General Safety Instructions None |
| Personnel Required MOS 63S, Heavy wheel vehicle mechanic | |

Electrical System Maintenance Instructions (Cont)

7-10. ENGINE HIGH IDLE BOX REMOVAL/REPAIR/INSTALLATION (M977, M985) (CONT).

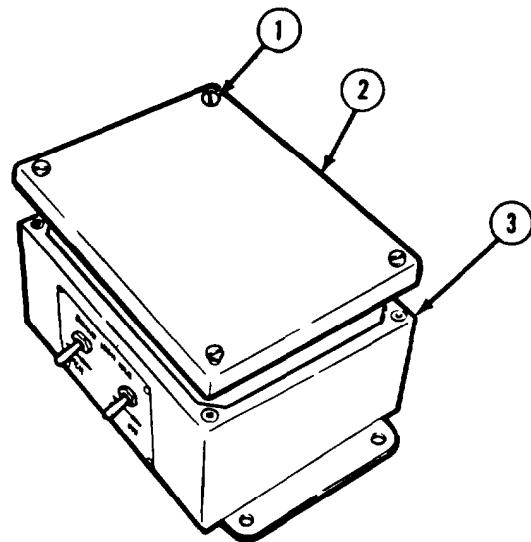
a. Removal.

- (1) Deleted.
- (2) Disconnect connector (3) from connector (2).
- (3) Remove four screws (4), lockwashers (5), nuts (6), and ENGINE HIGH IDLE box (7) from fender (8).



b. Disassembly.

- (1) Loosen four screws (1) and remove cover (2) from ENGINE HIGH IDLE box (3).



Electrical System Maintenance Instructions (Cont)

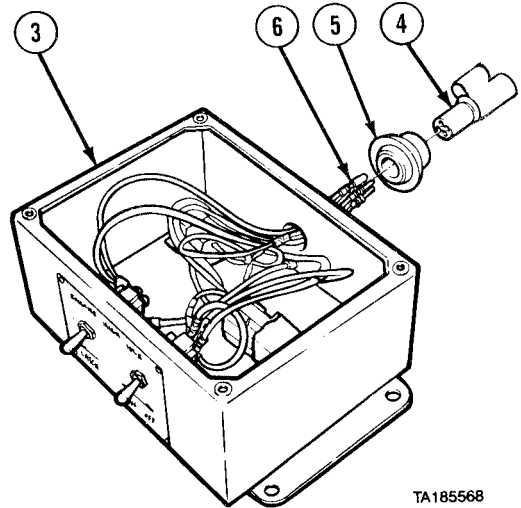
(2) Remove connector (4) from grommet (5).

NOTE

Tag and mark all wires before removing.

(3) Remove four wires (6) from connector (4).

(4) Remove grommet (5) from ENGINE HIGH IDLE box (3) and four wires (6).



NOTE

- LATCH and ON/OFF switches are removed in a similar manner.

- Tag and mark all wires before removal.

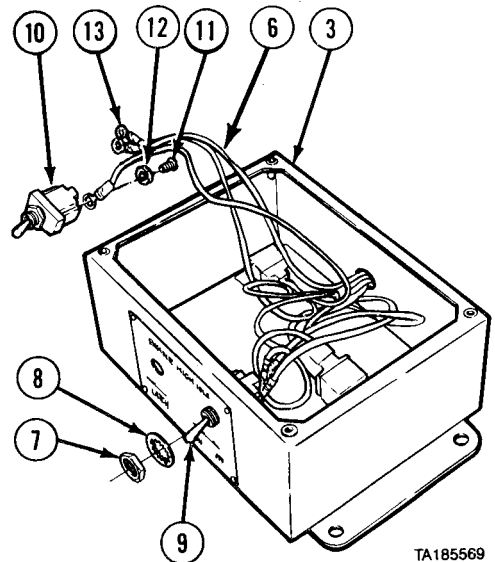
(5) Remove two nuts (7) and lockwashers (8) from switches (9 and 10).

(6) Remove two switches (9 and 10) from ENGINE HIGH IDLE box (3).

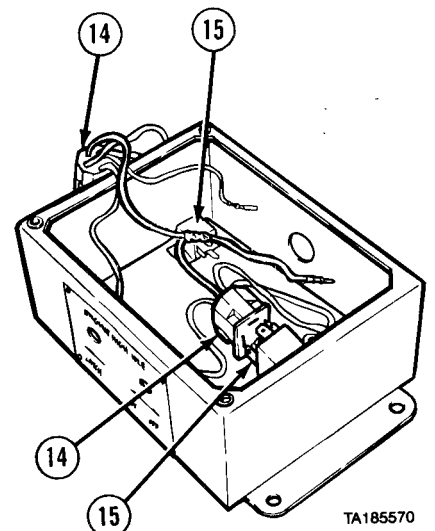
NOTE

One wire on LATCH switch center terminal is not connected to relays. Refer to Figure 7-1.

(7) Remove four screws (11), lockwashers (12), and six wires (13 and 6) from two switches (9 and 10).



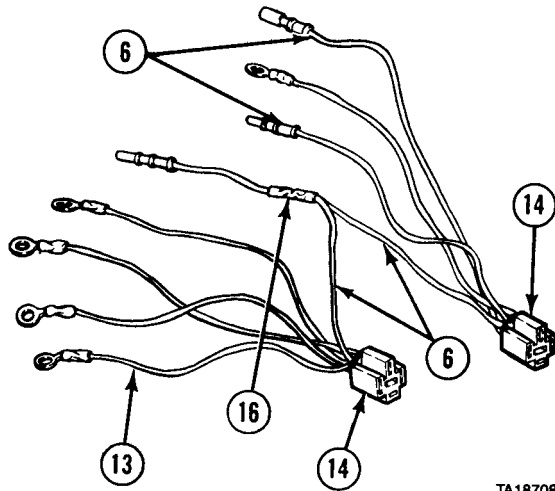
(8) Remove two connectors (14) from two relays (15).



Electrical System Maintenance Instructions (Cont)

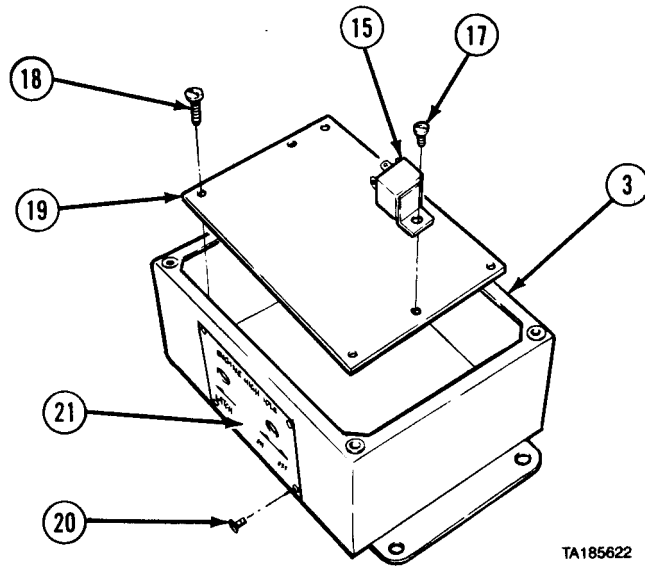
7-10. ENGINE HIGH IDLE BOX REMOVAL/REPAIR/INSTALLATION (M977, M985) (CONT).

- (9) Remove four wires (6) and five wires (13) from two connectors (14).
- (10) Remove electrical butt connector (16) from wires (6).



TA187082

- (11) Remove two screws (17) and relays (15).
- (12) Remove four screws (18) and plate (19) from ENGINE HIGH IDLE box (3).
- (13) Remove four screws (20) and data plate (21).

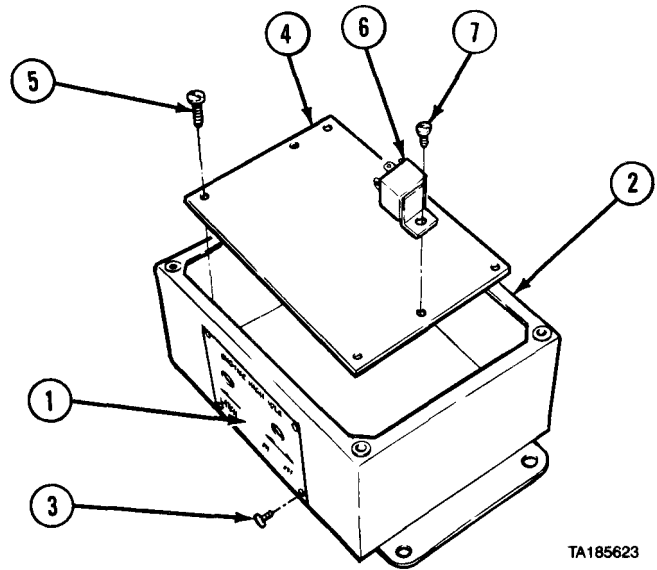


TA185622

Electrical System Maintenance Instructions (Cont)

c. Assembly.

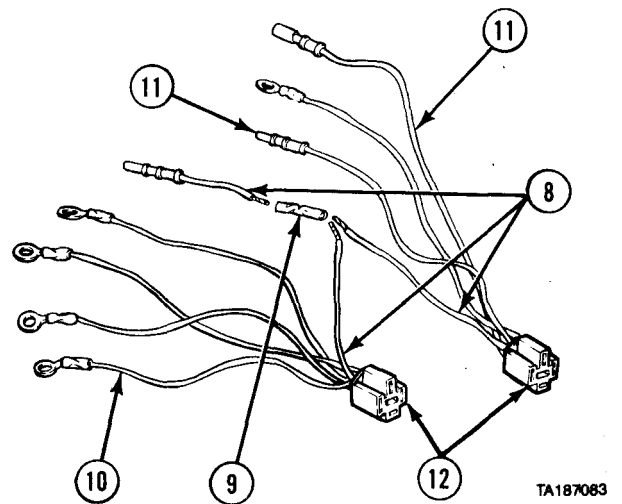
- (1) Install data plate (1) on ENGINE HIGH IDLE box (2) with four screws (3).
- (2) Install plate (4) in ENGINE HIGH IDLE box (2) with four screws (5).
- (3) Install two relays (6) on plate (4) with two screws (7).



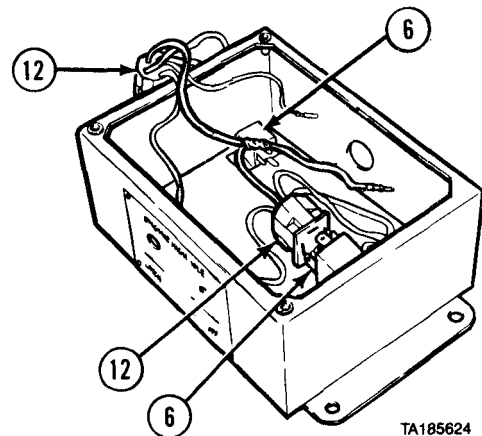
NOTE

Figure 7-1 is wiring diagram for ENGINE HIGH IDLE box.

- (4) Connect three wires (8) with electrical butt connector (9).
- (5) Install two wires (8), five wires (10), and two wires (11) in two connectors (12).



- (6) Connect two connectors (12) on two relays (6).



Electrical System Maintenance Instructions (Cont)

7-10. ENGINE HIGH IDLE BOX REMOVAL/REPAIR/INSTALLATION (M977, M985) (CONT).

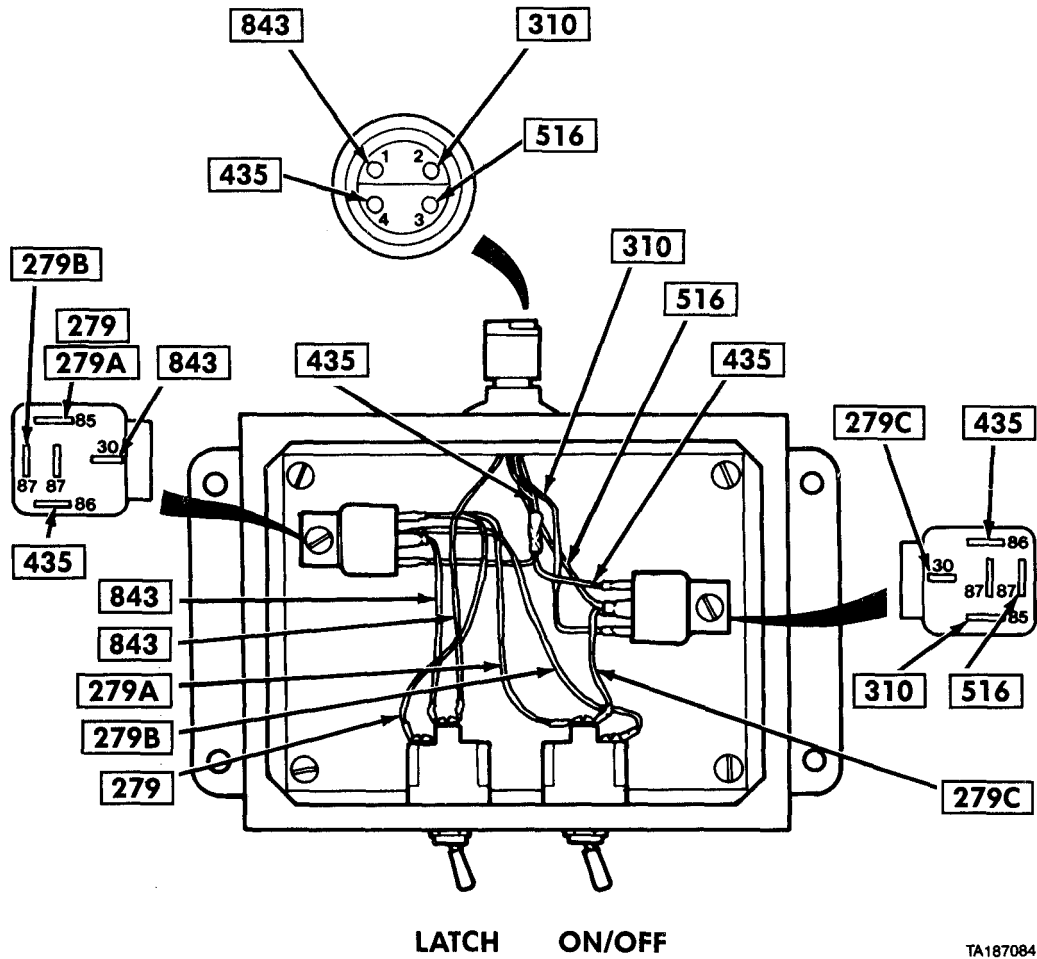
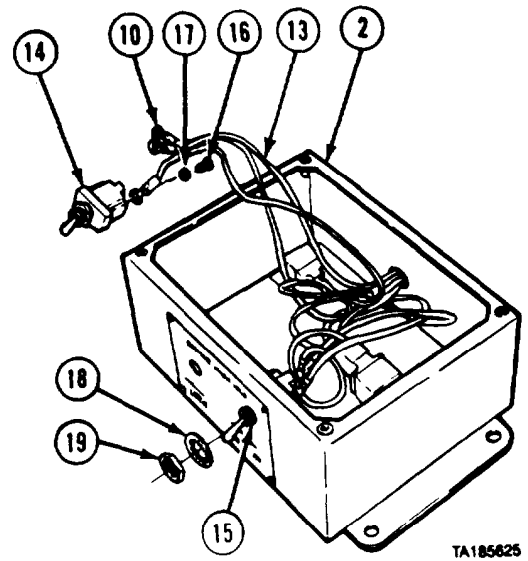


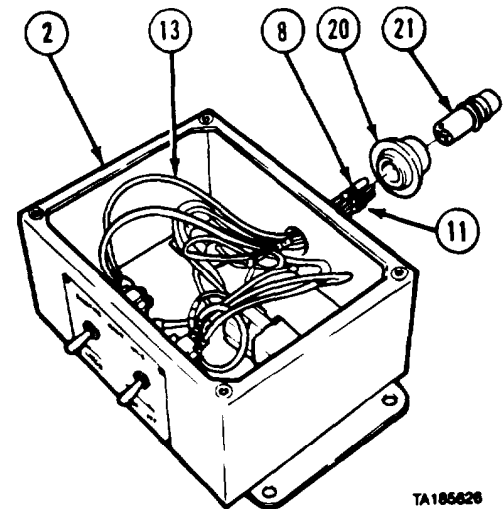
Figure 7-1. ENGINE HIGH IDLE Box Assembly Wiring Diagram (M977, M985).

Electrical System Maintenance Instructions (Cont)

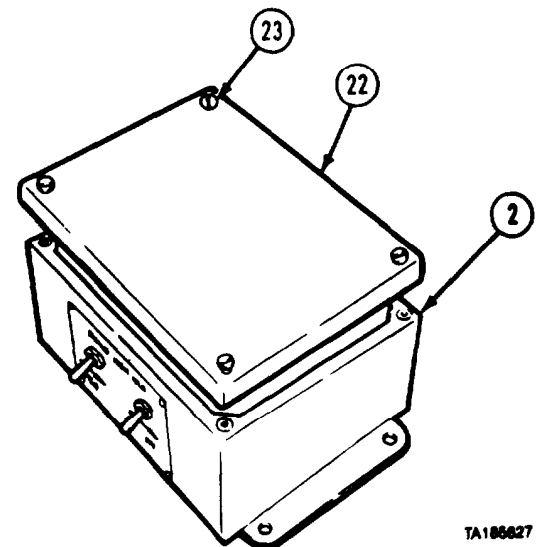
- (7) Install five wires (10) and wire (13) on two switches (14 and 15) with four screws (16) and lockwashers (17).
- (8) Install two switches (14 and 15) in ENGINE HIGH IDLE box (2) with two lockwashers (18) and nuts (19).



- (9) Install grommet (20) in ENGINE HIGH IDLE box (2). Push four wires (8, 11, and 13) through grommet.
- (10) Install four wires (8, 11, and 13) in connector (21).
- (11) Install connector (21) in grommet (20).



- (12) Install cover (22) on ENGINE HIGH IDLE box (2) with four screws (23).



Electrical System Maintenance Instructions (Cont)

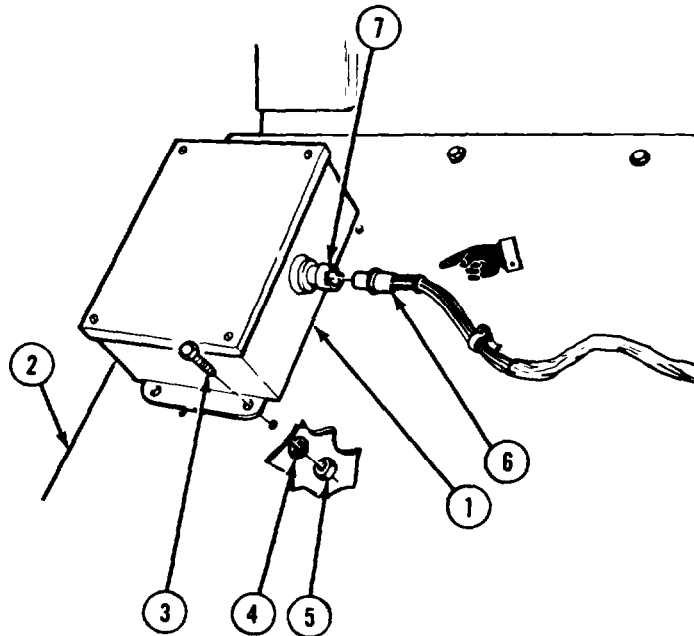
7-10. ENGINE HIGH IDLE BOX REMOVAL/REPAIR/INSTALLATION (M977, M985) (CONT).

d. Installation.

- (1) Install ENGINE HIGH IDLE box (1) on fender (2) with four screws (3), lockwashers (4), and nuts (5).
- (2) Connect connector (6) to connector (7).
- (3) Deleted.

e. Follow-on Maintenance

- (1) Connect batteries (para 7-91).
- (2) Check operation of LATCH and ON/OFF SWITCHES. (TM 9-2320-279-10).



END OF TASK

7-11. ENGINE HIGH IDLE BOX, CONNECTOR, SWITCHES, AND BRACKET REMOVAL/INSTALLATION (CRANE MOUNTED) (M984, M985E1).

This task covers:

- a. Removal (M984)
- b. Installation (M984)
- c. Removal (M985E1)
- d. Installation (M985E1)
- e. Follow-on Maintenance

INITIAL SETUP

Models
M984, M985E1

Test Equipment
None

Special Tools
None

Supplies
Connector, electrical, butt, Item 19, Appendix C
Tags, identification, Item 48, Appendix C
Compound, sealing, pipe thread, Item 18, Appendix C

Personnel Required
MOS 63S, Heavy wheel vehicle mechanic

References
None

Equipment Condition
TM or Para *Condition Description*
Para 7-91 Batteries disconnected.

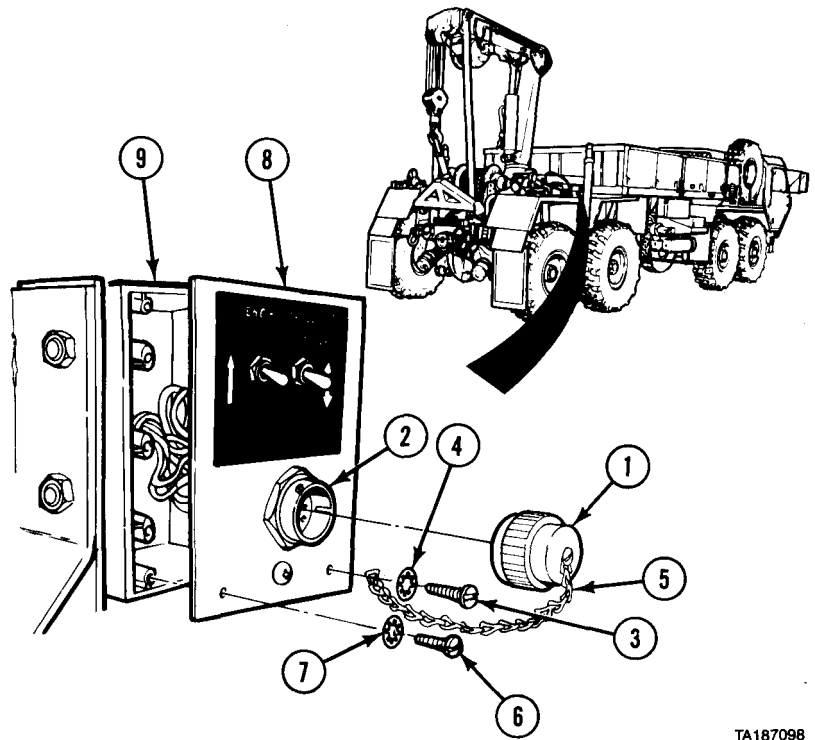
Special Environmental Conditions
None

General Safety, Instructions
None

Electrical System Maintenance Instructions (Cont)

a. Removal (M984).

- (1) Remove cap (1) from connector (2).
- (2) Remove screw (3), lockwasher (4), chain (5), and cap (1).
- (3) Remove five screws (6) and lockwashers (7) from cover (8).
- (4) Pull cover (8) away from ENGINE HIGH IDLE box (9).

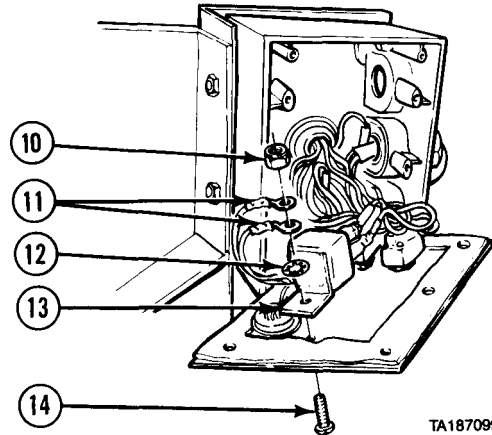


TA187098

NOTE

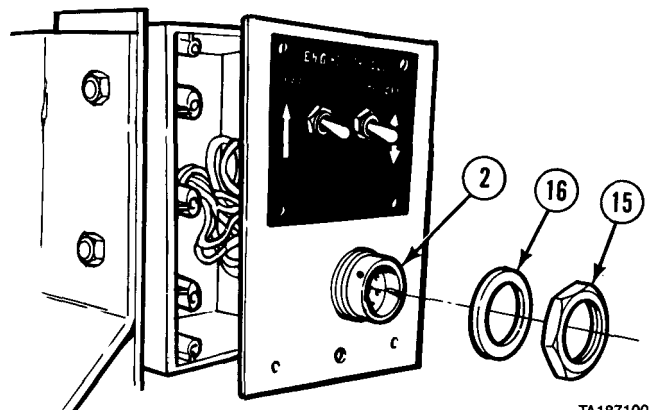
Tag and mark all wires.

- (5) Remove locknut (10), two wires (11), lockwasher (12), relay (13), and screw (14).



TA187099

- (6) Remove nut (15) and lockwasher (16) from connector (2).



TA187100

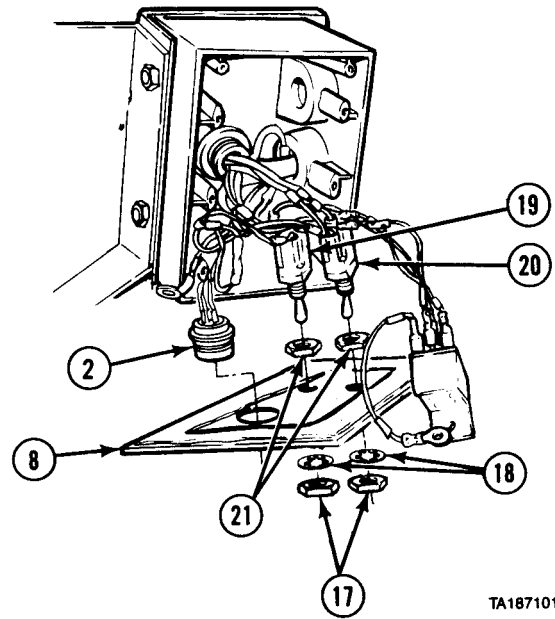
Electrical System Maintenance Instructions (Cont)

7-11. ENGINE HIGH IDLE BOX, CONNECTOR, SWITCHES, AND BRACKET
REMOVAL/INSTALLATION (CRANE MOUNTED) (M984, M985E1) (CONT).

NOTE

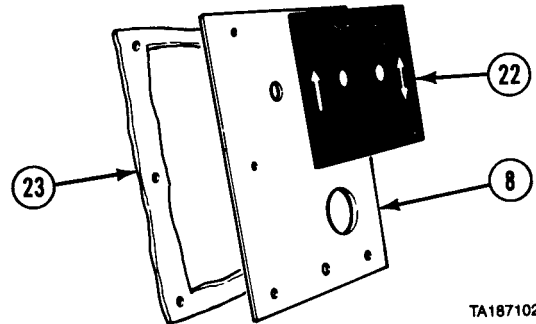
Note position of switches.

- (7) Remove two nuts (17) and lockwashers (18) from ON/OFF switch (19) and LATCH switch (20).
- (8) Remove cover (8) from ON/OFF switch (19), LATCH switch (20), and connector (2).
- (9) Remove two nuts (21) from ON/OFF switch (19) and LATCH switch (20).



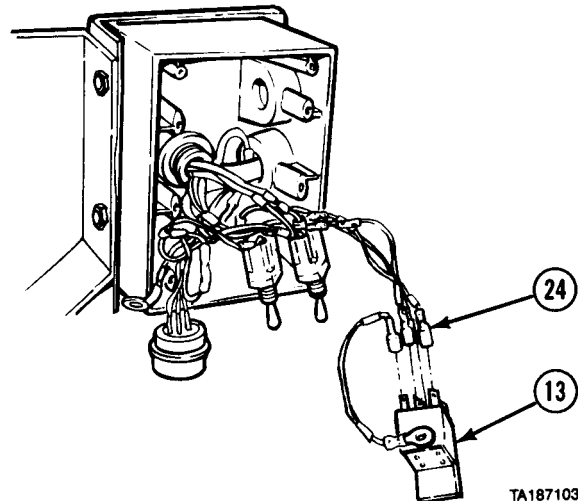
TA187101

- (10) Remove data plate (22) and gasket (23) from cover (8).



TA187102

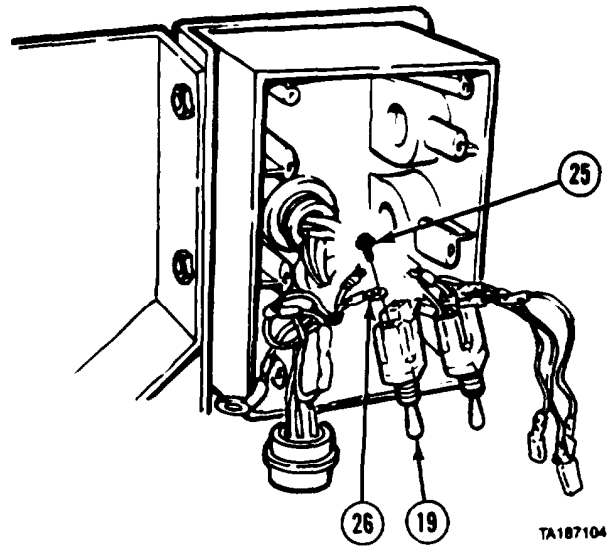
- (11) Disconnect five wires (24) from relay (13).



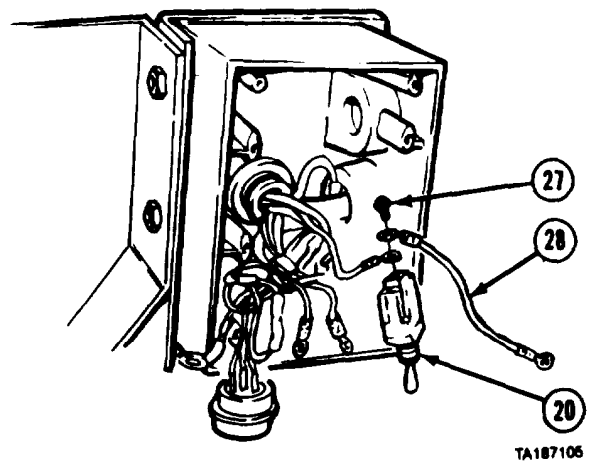
TA187103

Electrical System Maintenance Instructions (Cont)

- (12) Remove two screws (25) and six wires (26) from ON/OFF switch (19).

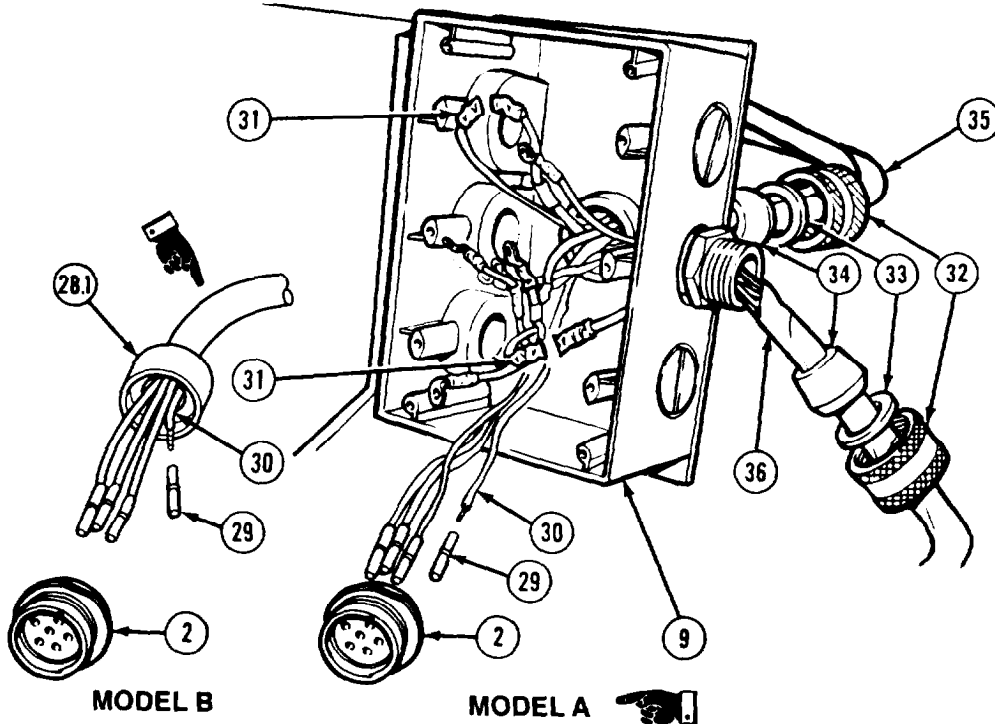


- (13) Remove three screws (27) and four wires (28) from LATCH switch (20).



Electrical System Maintenance Instructions (Cont)

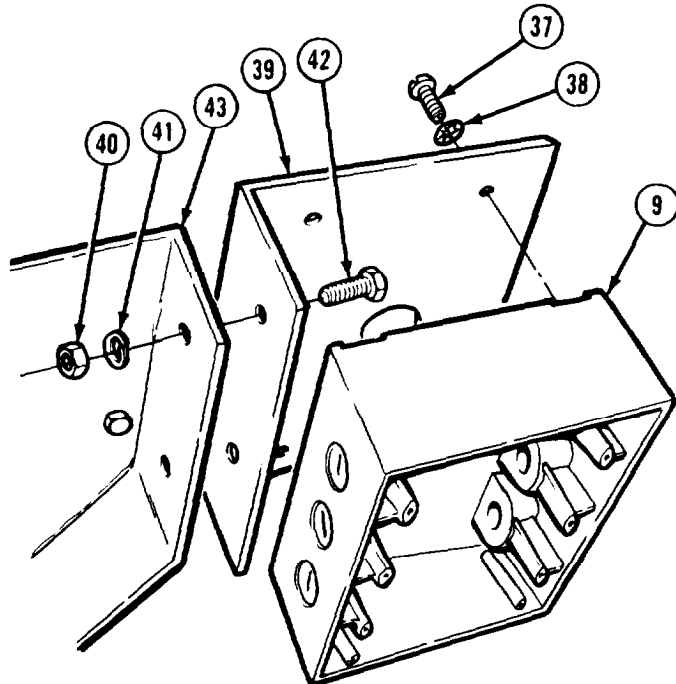
7-11. ENGINE HIGH IDLE BOX CONNECTOR SWITCHES AND BRACKET REMOVAL/INSTALLATION (CRANE MOUNTED) (M984, M985E1) (CONT).



NOTE

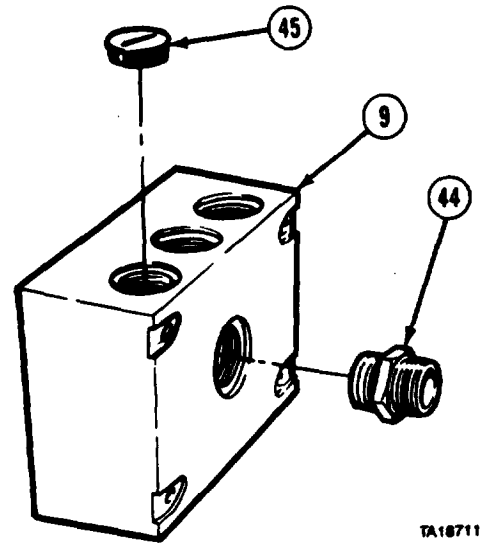
There are two models of wiring harnesses. Model A has no boot. Model B has a boot. Perform steps (13.1 and 15.1) for Model B only.

- (13.1) Slide back boot (28.1) from connector (2).
- (14) Remove four pins (29) from connector (2).
- (15) Remove four pins (29) from wires (30).
- (15.1) Remove boot (28.1) from wires (30).
- (16) Cut two electrical butt connectors (31).
- (17) Loosen two caps (32) and slide rings (33) and grommets (34) back on wire harnesses (35 and 36).
- (18) Remove two wire harnesses (35 and 36) from ENGINE HIGH IDLE box (9).
- (19) Remove four screws (37), lockwashers (38), and ENGINE HIGH IDLE box (9) from bracket (39).
- (20) Remove two nuts (40), lockwashers (41), screws (42), and bracket (39) from valve bank body bracket (43).



Electrical System Maintenance Instructions (Cont)

- (21) Remove two fittings (44) and five plugs (46) from ENGINE HIGH IDLE box (9).



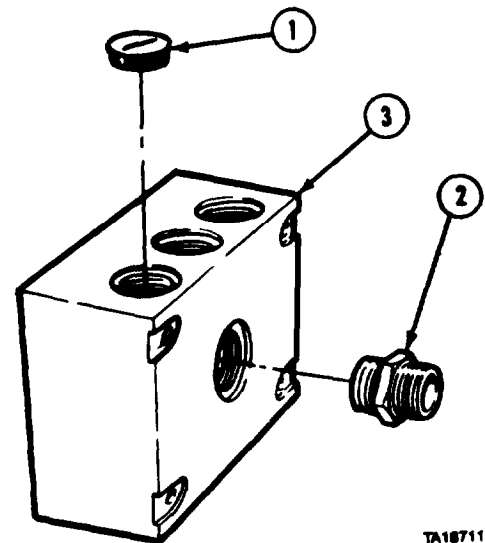
TA187117

b. Installation (M984).

WARNING

Adhesives, solvents, and sealing compounds can burn easily, can give off harmful vapors, and are harmful to skin and clothing. To avoid injury or death, keep away from open fire and use in well-ventilated area. If adhesive, solvent, or sealing compound gets on skin or clothing, wash immediately with soap and water.

- (1) Coat threads of five plugs (1) with pipe thread sealing compound and install plugs and two fittings (2) in ENGINE HIGH IDLE box (3).

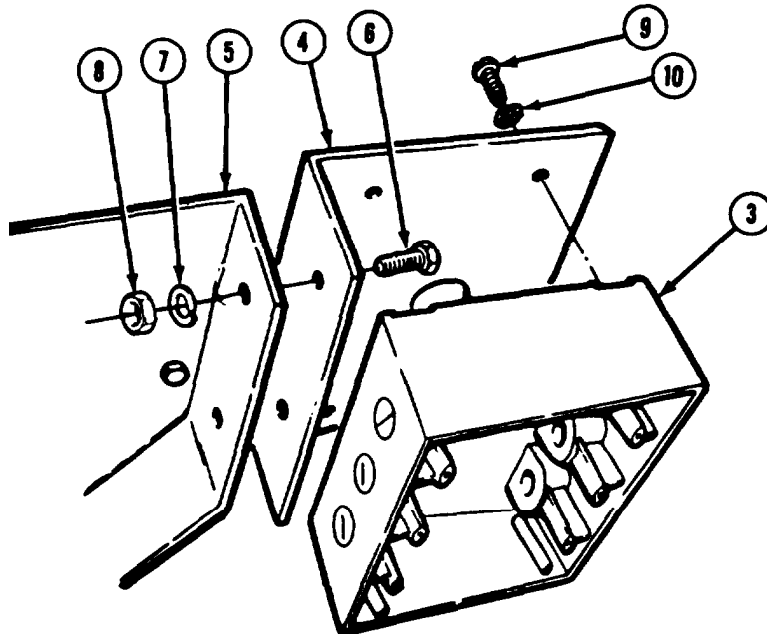


TA187118

Electrical System Maintenance Instructions (Cont)

**7-11. ENGINE HIGH IDLE BOX CONNECTOR SWITCHES AND BRACKET
REMOVAL/INSTALLATION (CRANE MOUNTED) (M984, M985E1) (CONT).**

- (2) Install bracket (4) on valve ban body bracket (5) with two screws (6), lockwashers (7), and nuts (8).
- (3) Install ENGINE HIGH IDLE box (3) on bracket (4) with four screws (9) and lockwashers (10).

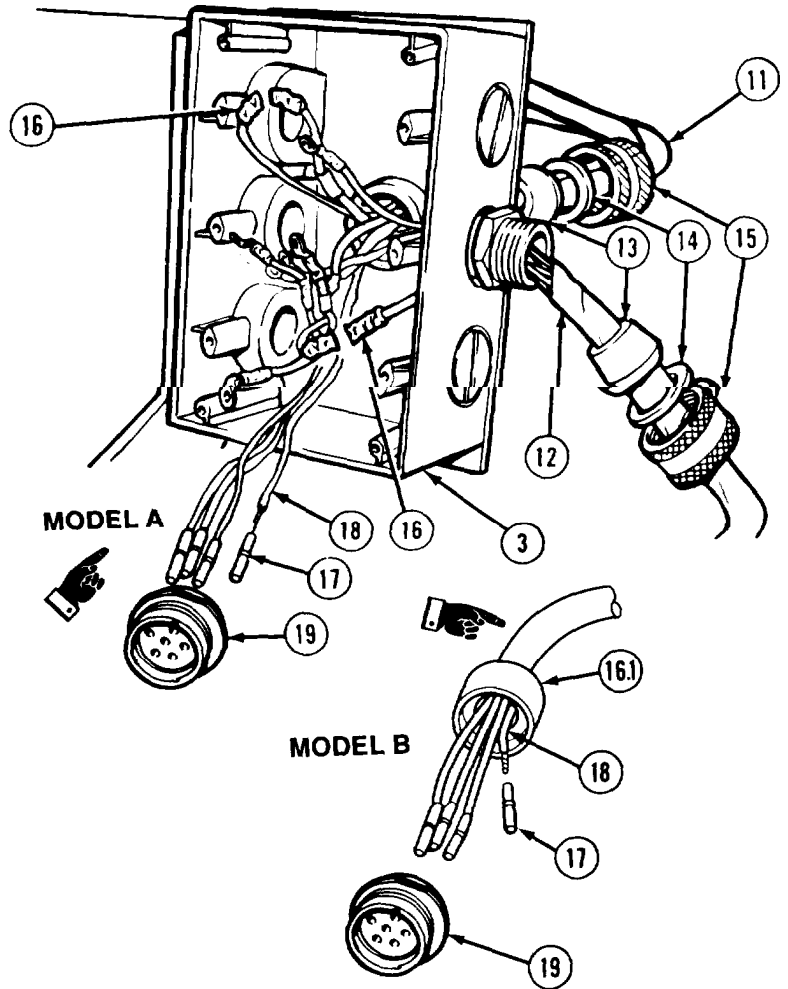


Electrical System Maintenance Instructions (Cont)

NOTE

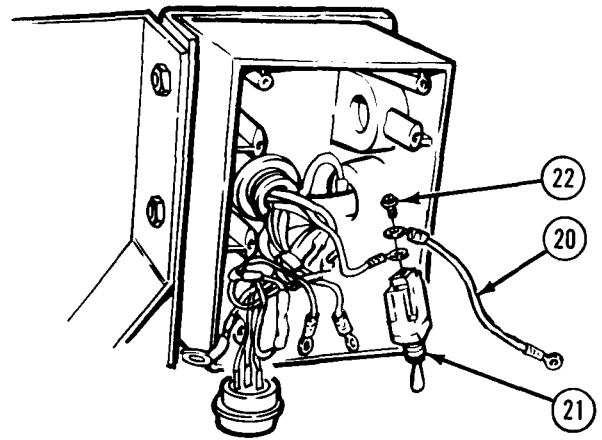
There are two models of wiring harnesses. Model A has no boot. Model B has a boot covering back side of connector. Perform steps (5.1 and 7.1) for Model B only.

- (4) Install two wire harnesses (11 and 12) in ENGINE HIGH IDLE box (3) with two grommets (13), rings (14), and caps (15).
- (5) Install two electrical butt connectors (16).
- (5.1) Install boot (16.1) over wires (18).
- (6) Install four pins (17) on wires (18).
- (7) Install four pins (17) in connector (19).
- (7.1) Slide boot (16.1) over connector (19).



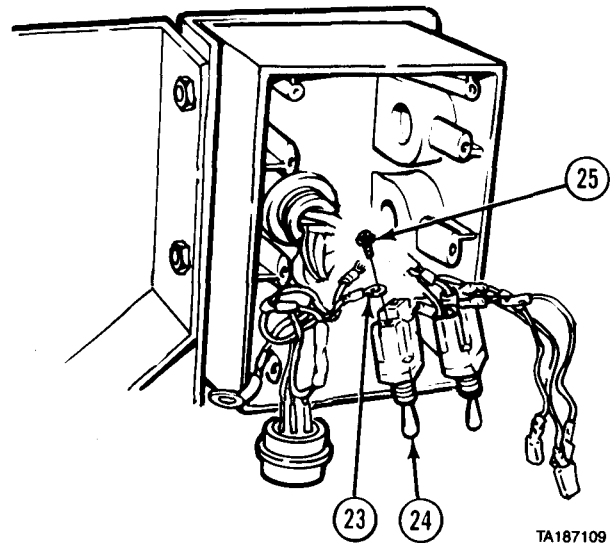
Electrical System Maintenance Instructions (Cont)

- (8) Install four wires (20) on LATCH switch (21) with three screws (22).



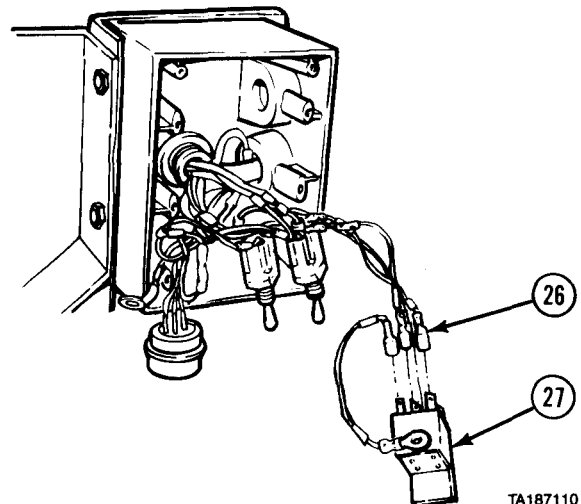
TA187108

- (9) Install six wires (23) on ON/OFF switch (24) with two screws (25).



TA187109

- (10) Connect five wires (26) to relay (27).

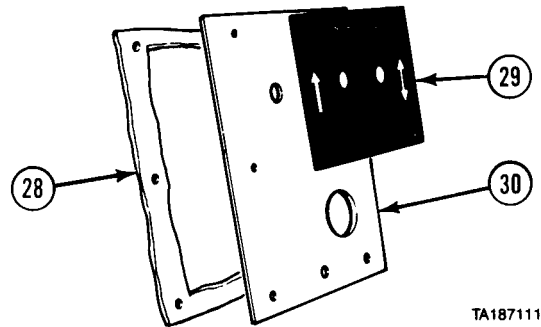


TA187110

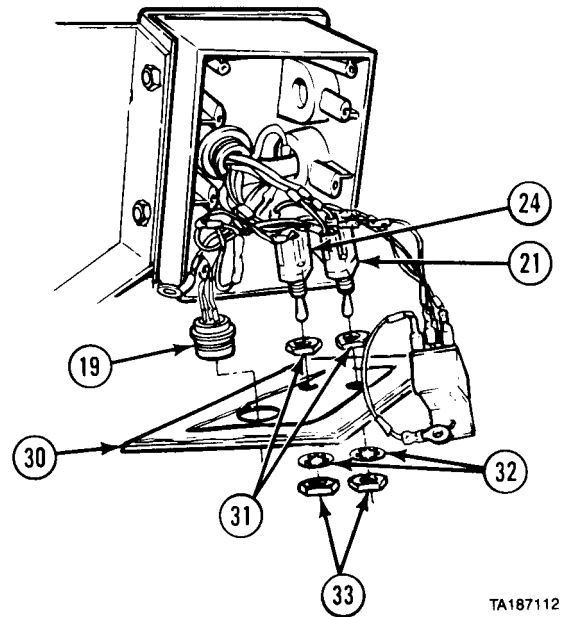
Electrical System Maintenance Instructions (Cont)

7-11. ENGINE HIGH IDLE BOX, CONNECTOR, SWITCHES, AND BRACKET
REMOVAL/INSTALLATION (CRANE MOUNTED) (M984, M985E1) (CONT).

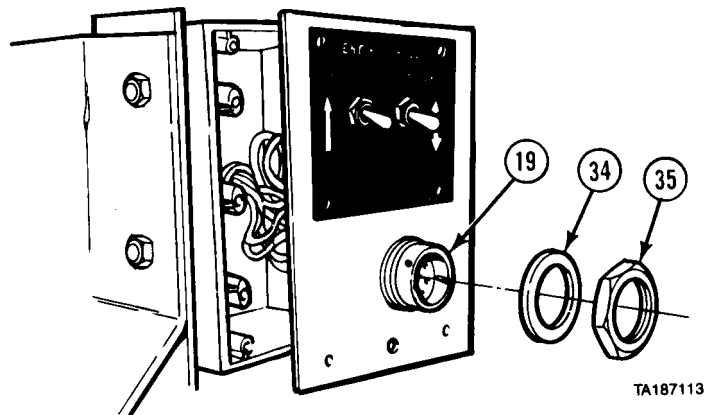
(16) Install gasket (28) and date plate (29) on cover (30).



- (12) Install two nuts (31) on LATCH switch (21) and ON/OFF switch (24).
- (13) Install cover (30) over connector (19), LATCH switch (21), and ON/OFF switch (24).
- (14) Install two lockwashers (32) and nuts (33) on LATCH switch (21) and ON/OFF switch (24).

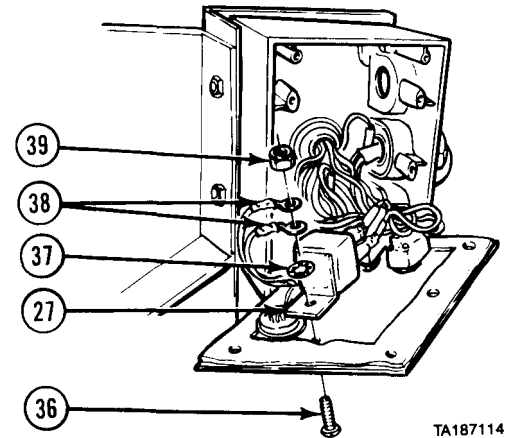


(15) Install lockwasher (34) and nut (35) on connector (19).



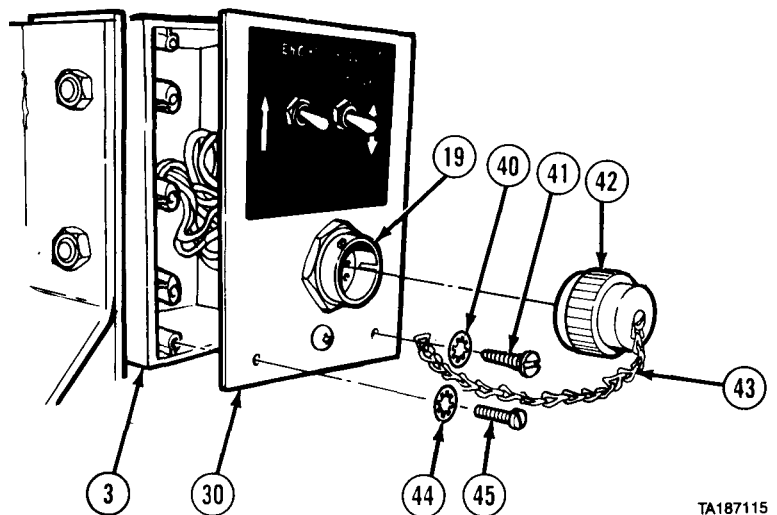
Electrical System Maintenance Instructions (Cont)

- (16) Install screw (36), relay (27), lockwasher (37), two wires (38), and locknut (39).



TA187114

- (17) Install cover (30) on ENGINE HIGH IDLE box (3) with five lockwashers (40) and screws (41).
 (18) Install cap (42) and chain (43) with lockwasher (44) and screw (45).
 (19) Install cap (42) on connector (19).



TA187115

Electrical System Maintenance Instructions (Cont)

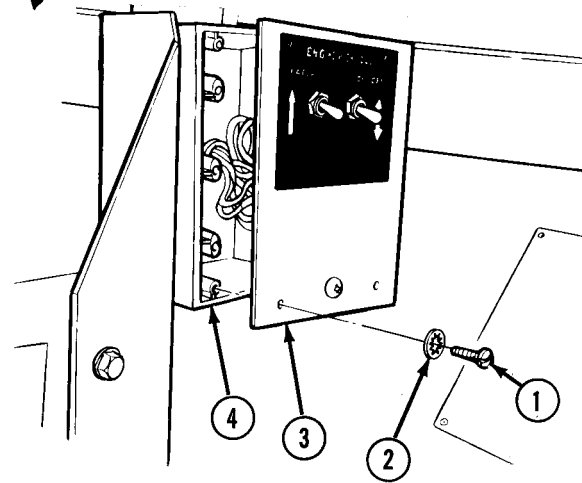
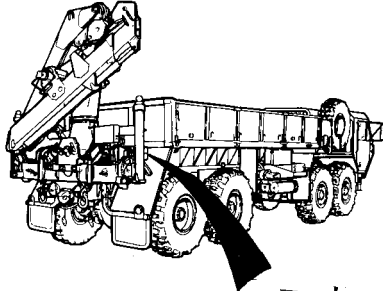
7-11. ENGINE HIGH IDLE BOX, CONNECTOR, SWITCHES, AND BRACKET REMOVAL/INSTALLATION (CRANE MOUNTED) (M984, M985E1) (CONT).

c. Removal (M985E1).

NOTE

Tag and mark all wires and components.

- (1) Remove six screws (1) and lockwashers (2) from cover (3).
- (2) Pull cover (3) away from ENGINE HIGH IDLE box (4).



NOTE

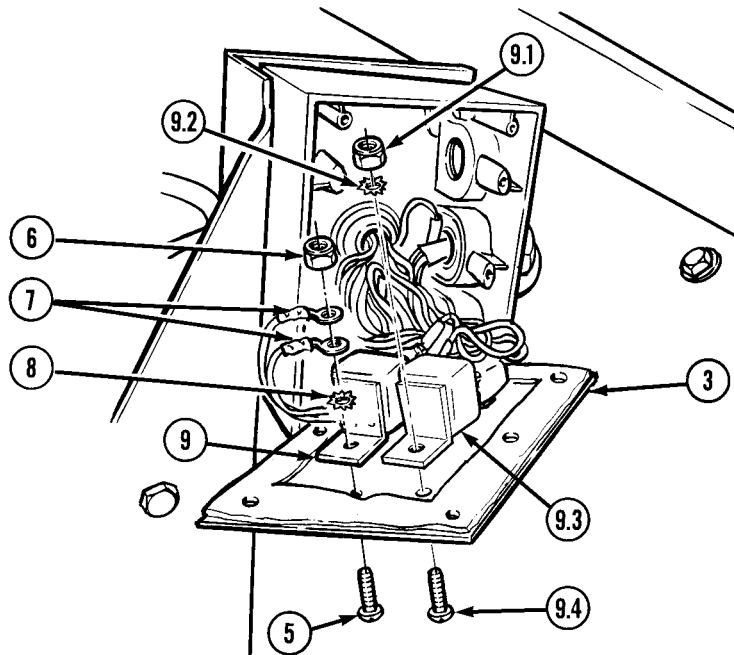
Some vehicles have two wires. Others have three.

- (3) Remove screw (5), locknut (6), wires (7), lockwasher (8), and relay (9) from cover (3).

NOTE

Some vehicles have a CRANE OUTRIGGERS EXTENDED indicator relay. Others do not. For vehicles that have a CRANE OUTRIGGERS EXTENDED indicator relay, do step (3.1).

- (3.1) Remove locknut (9.1), lockwasher (9.2), CRANE OUTRIGGERS EXTENDED indicator relay (9.3), and screw (9.4) from cover (3).

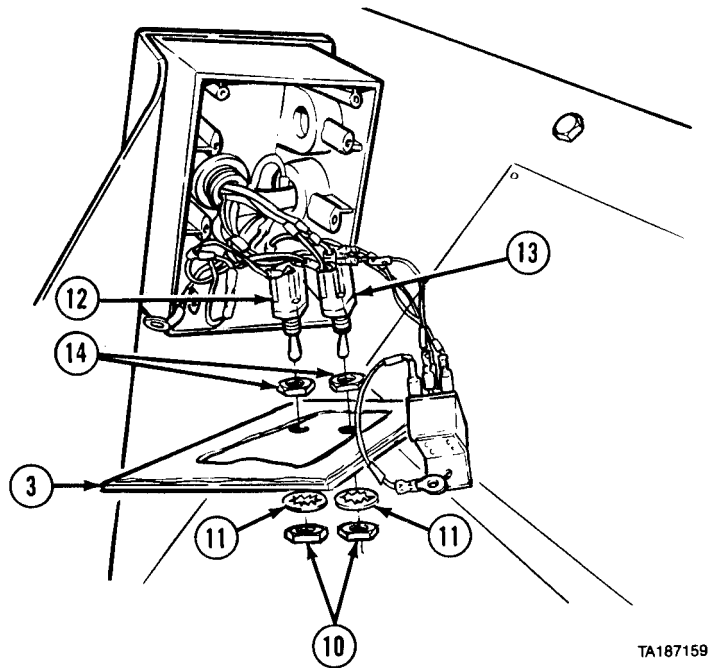


Electrical System Maintenance Instructions (Cont)

NOTE

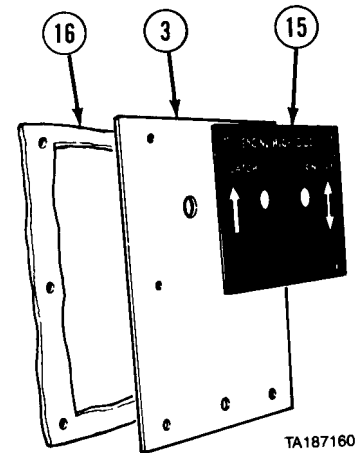
Note position of switches.

- (4) Remove two nuts (10) and lockwashers (11) from ON/OFF switch (12) and LATCH switch (13).
- (5) Remove cover (3) from switches (12 and 13).
- (6) Remove two nuts (14) from ON/OFF switch (12) and LATCH switch (13).



TA187159

- (7) Remove data plate (15) and gasket (16) from cover (3).



TA187160

Electrical System Maintenance Instructions (Cont)

**7-11. ENGINE HIGH IDLE BOX, CONNECTOR, SWITCHES, AND BRACKET
REMOVAL/INSTALLATION (CRANE MOUNTED) (M984, M985E1) (CONT).**

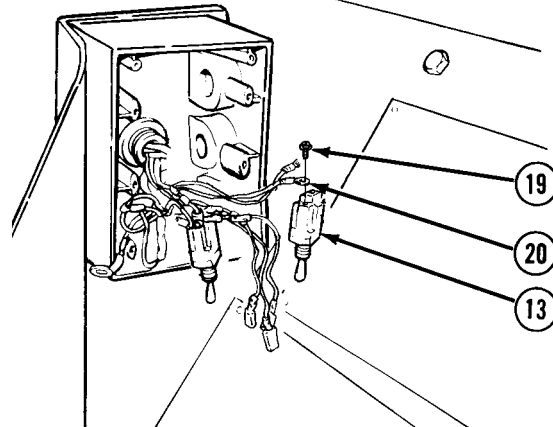
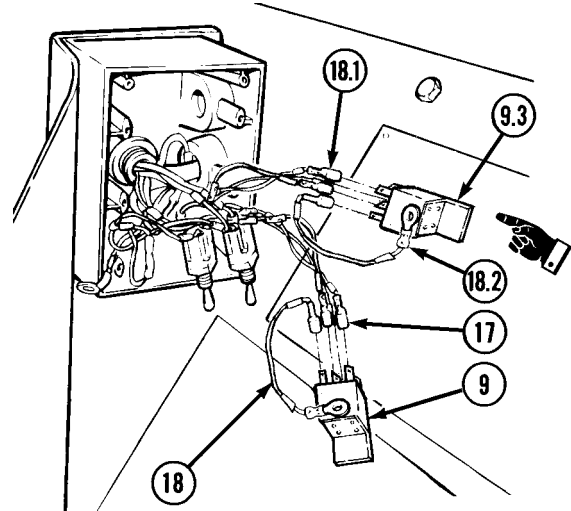
- (8) Disconnect three wires (17) and remove wire (18) from relay (9).

NOTE

Some vehicles have a CRANE OUTRIGGERS EXTENDED indicator relay. Others do not. For vehicles that have a CRANE OUTRIGGERS EXTENDED indicator relay, do step (8.1).

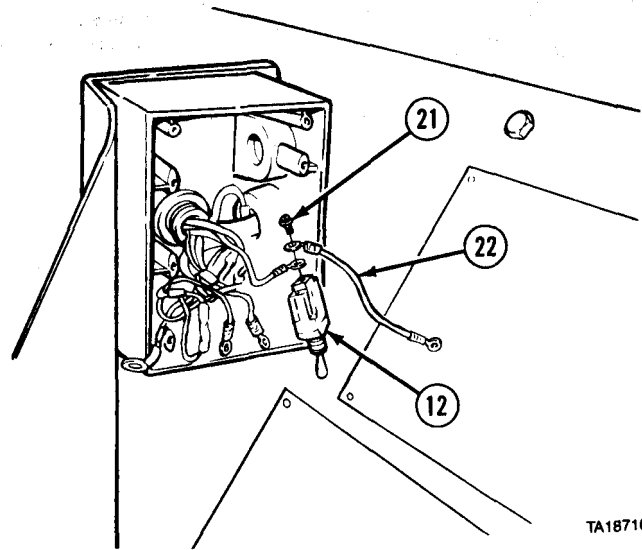
- (8.1) Disconnect three wires (18.1) and remove wire (18.2) from CRANE OUTRIGGERS EXTENDED indicator relay (9.3).

- (9) Remove three screws (19) and four wires (20) from LATCH switch (13).



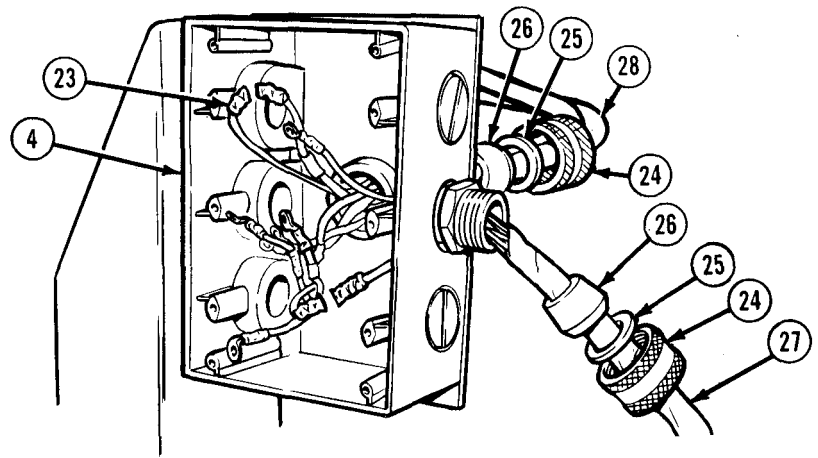
Electrical System Maintenance Instructions (Cont)

- (10) Remove two screws (21) and six wires (22) from ON/OFF switch (12).



TA187163

- (11) Cut two electrical butt connectors (23).
 (12) Loosen two nuts (24) and slide rings (25) and grommets (26) back on wire harnesses (27 and 28).
 (13) Remove two wire harnesses (27 and 28) from ENGINE HIGH IDLE box (4).

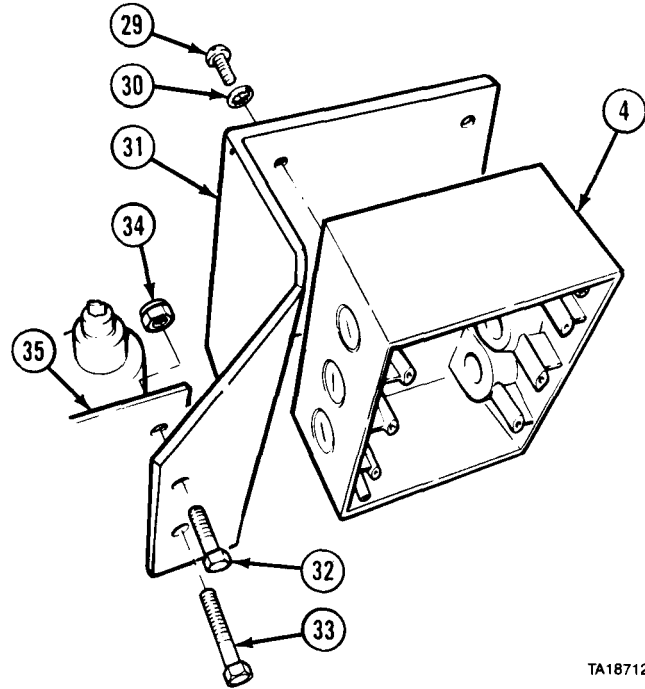


TA187164

Electrical System Maintenance Instructions (Cont)

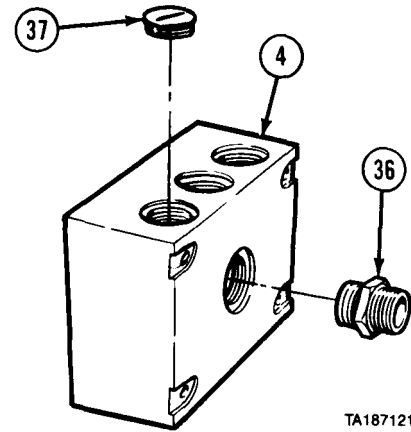
7-11. ENGINE HIGH IDLE BOX, CONNECTOR, SWITCHES, AND BRACKET
REMOVAL/INSTALLATION (CRANE MOUNTED) (M984, M985E1) (CONT).

- (14) Remove four screws (29), lockwashers (30), and ENGINE HIGH IDLE box (4) from mounting bracket (31).
- (15) Remove two screws (32 and 33), nuts (34), and mounting bracket (31) from crane (35).



TA187120

- (16) Remove two fittings (36) and five plugs (37) from ENGINE HIGH IDLE box (4).



TA187121

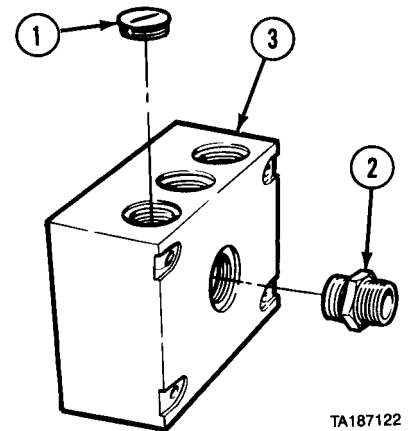
Electrical System Maintenance Instructions (Cont)

d. Installation (M985E1).

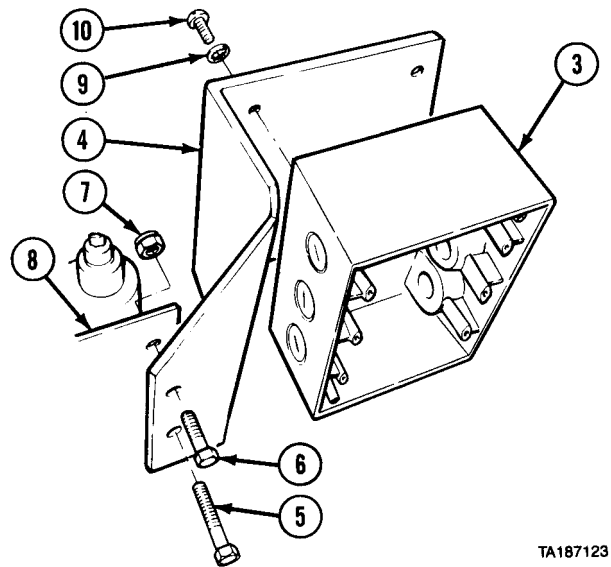
WARNING

Adhesives, solvents, and sealing compounds can burn easily, can give off harmful vapors, and are harmful to skin and clothing. To avoid injury or death, keep away from open fire and use in well-ventilated area. If adhesive, solvent, or sealing compound gets on skin or clothing, wash immediately with soap and water.

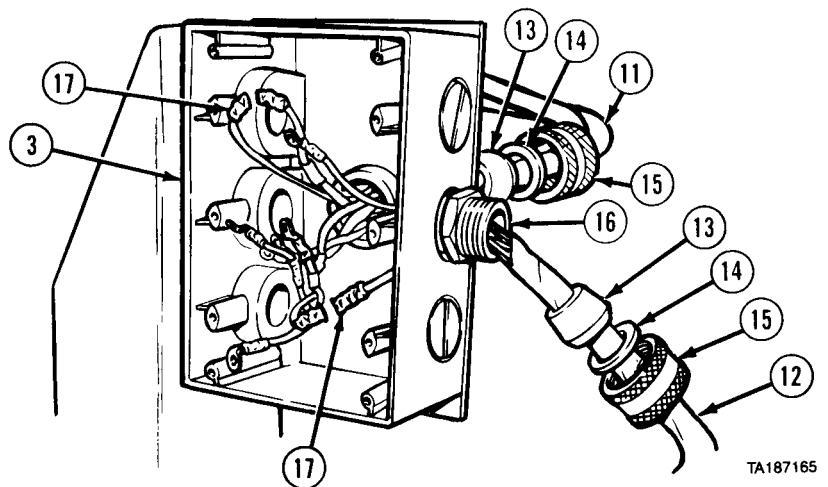
- (1) Coat threads of five plugs (1) with pipe thread sealing compound and install plugs and two fittings (2) in ENGINE HIGH IDLE box (3).



- (2) Install mounting bracket (4) with two screws (5 and 6) and nuts (7) to crane (8).
- (3) Install ENGINE HIGH IDLE box (3) with four lockwashers (9) and screws (10) on mounting bracket (4).



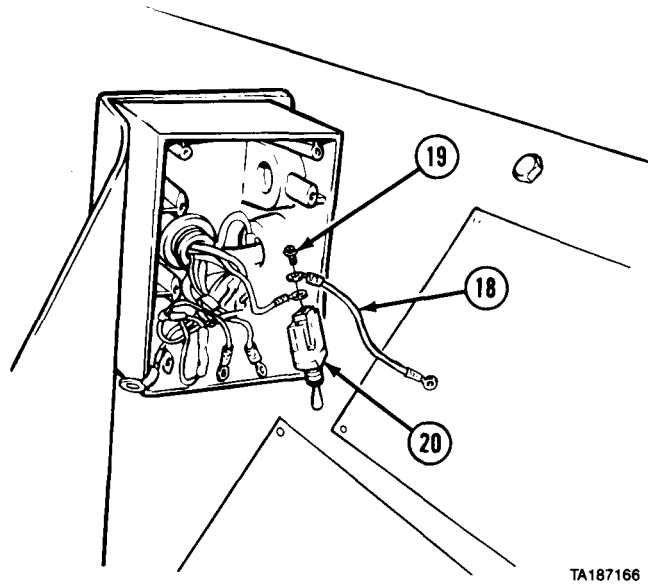
- (4) Install two wires harnesses (11 and 12) in ENGINE HIGH IDLE box (3).
- (5) Install two grommets (13), rings (14), and nuts (15) on connectors (16).
- (6) Install two electrical butt connectors (17).



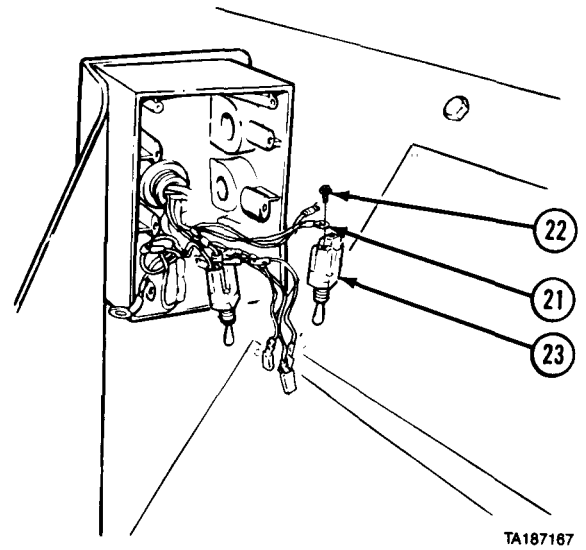
Electrical System Maintenance Instructions (Cont)

7-11. ENGINE HIGH IDLE BOX, CONNECTOR, SWITCHES, AND BRACKET
REMOVAL/INSTALLATION (CRANE MOUNTED) (M984, M985E1) (CONT).

(7) Install six wires (18) with two screws (19) on ON/OFF switch (20).



(8) Install four wires (21) with three screws (22) on LATCH switch (23).



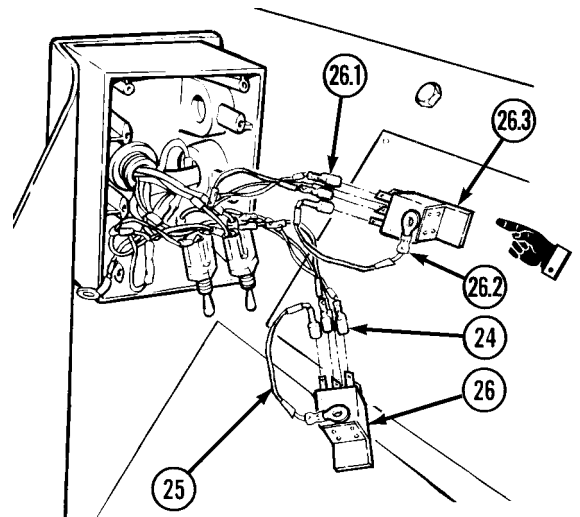
Electrical System Maintenance Instructions (Cont)

- (9) Connect three wires (24) and install wire (25) on relay (26).

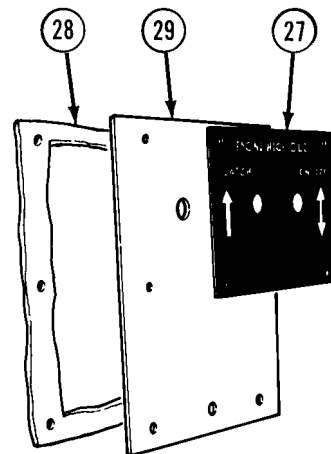
NOTE

Some vehicles have a CRANE OUTRIGGERS EXTENDED indicator relay. Others do not. For vehicles that have a CRANE OUTRIGGERS EXTENDED indicator relay, do step (9.1).

- (9.1) Connect three wires (26.1) and install wire (26.2) on CRANE OUTRIGGERS EXTENDED indicator relay (26.3).



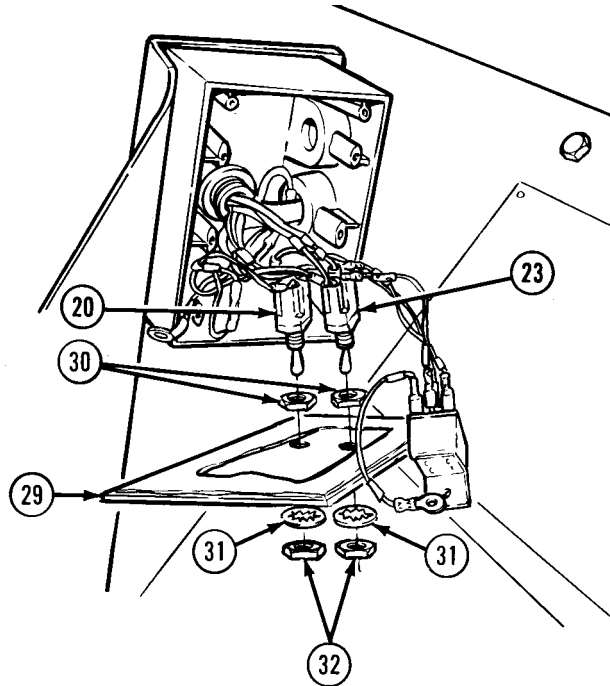
- (10) Install data plate (27) and gasket (28) on cover (29).



Electrical System Maintenance Instructions (Cont)

7-11. ENGINE HIGH IDLE BOX, CONNECTOR, SWITCHES, AND BRACKET REMOVAL/INSTALLATION (CRANE MOUNTED) (M984, M985E1) (CONT).

- (11) Install two nuts (30) on ON/OFF switch (20) and LATCH switch (23).
- (12) Install ON/OFF switch (20) and LATCH switch (23) in cover (29) with two lockwashers (31) and nuts (32).



NOTE

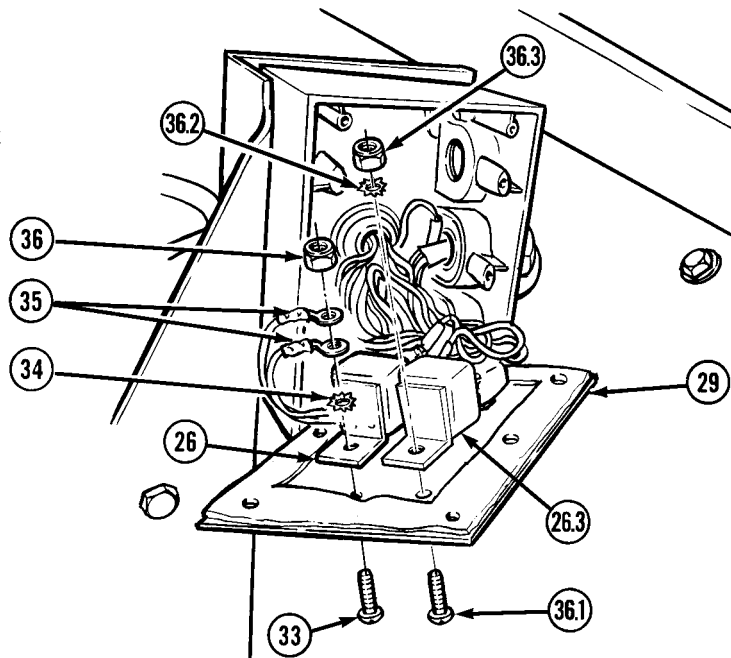
Vehicles that have a CRANE OUTRIGGERS EXTENDED indicator relay have three wires. Vehicles that do not have a CRANE OUTRIGGERS EXTENDED indicator relay have two wires.

- (13) Install screw (33), relay (26), lockwasher (34), wires (35), and locknut (36) on cover (29).

NOTE

Some vehicles have a CRANE OUTRIGGERS EXTENDED indicator relay. Others do not. For vehicles that have a CRANE OUTRIGGERS EXTENDED indicator relay, do step (13.1).

- (13.1) Install screw (36.1), CRANE OUTRIGGERS EXTENDED indicator relay (26.3), lockwasher (36.2), and locknut (36.3) on cover (29).



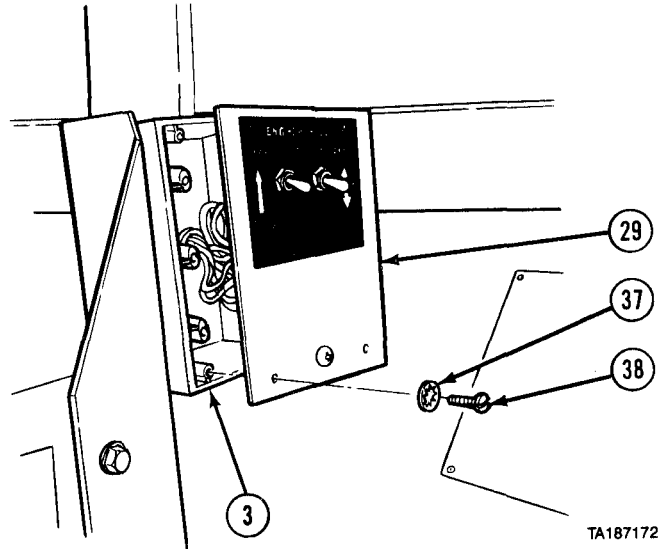
Electrical System Maintenance Instructions (Cont)

(14) Install cover (29) on ENGINE HIGH IDLE box (3) with six lockwashers (37) and screws (38).

e. Follow-on Maintenance.

- (1) Connect batteries (para 7-91).
- (2) Check operation of LATCH and ON/OFF switches (M984) (TM 9-2320-354-10), (M985E1) (TM 9-2320-355-10).

END OF TASK

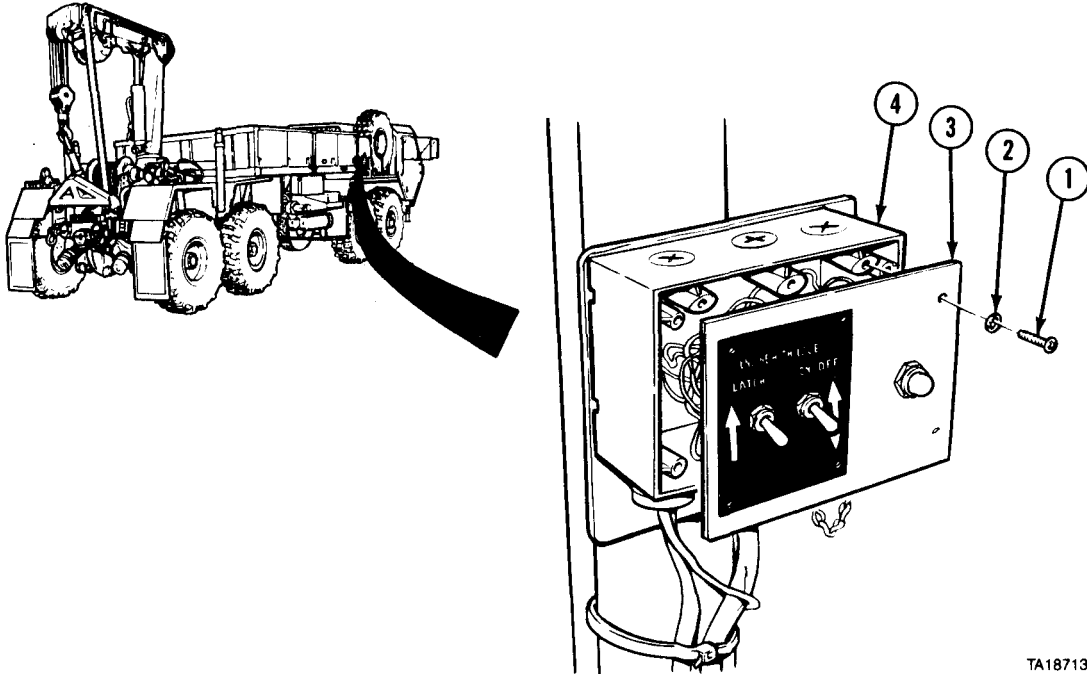


| | | |
|--|---|------------------------------|
| 7-12. ENGINE HIGH IDLE BOX, CONNECTORS, AND SWITCHES REMOVAL/INSTALLATION (TIRE DAVIT MOUNTED) (M984, M985E1). | | |
| This task covers: | | |
| a. Removal | c. Follow-on Maintenance | |
| b. Installation | | |
| INITIAL SETUP | | |
| <i>Models</i> | <i>References</i> | |
| M984, M985E1 | None | |
| <i>Test Equipment</i> | <i>Equipment Condition</i> | |
| None | <i>TM or Para</i> | <i>Condition Description</i> |
| <i>Special Tools</i> | Para 7-91 | Batteries disconnected. |
| None | <i>Special Environmental Conditions</i> | |
| <i>Supplies</i> | None | |
| Tags, identification, Item 48, Appendix C | <i>General Safety Instructions</i> | |
| <i>Personnel Required</i> | None | |
| MOS 63S, Heavy wheel vehicle mechanic | | |

Electrical System Maintenance Instructions (Cont)

7-12. ENGINE HIGH IDLE BOX, CONNECTORS, AND SWITCHES REMOVAL/INSTALLATION (TIRE DAVIT MOUNTED) (M984, M985E1) (CONT).

a. Removal.



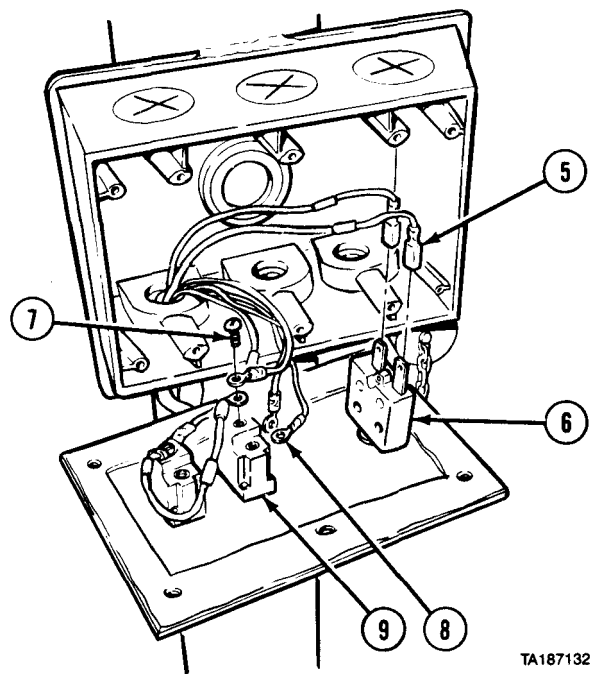
TA187131

- (1) Remove six screws (1) and lockwashers (2).
- (2) Remove cover (3) from ENGINE HIGH IDLE box (4).

NOTE

Tag and mark all wires before removal.

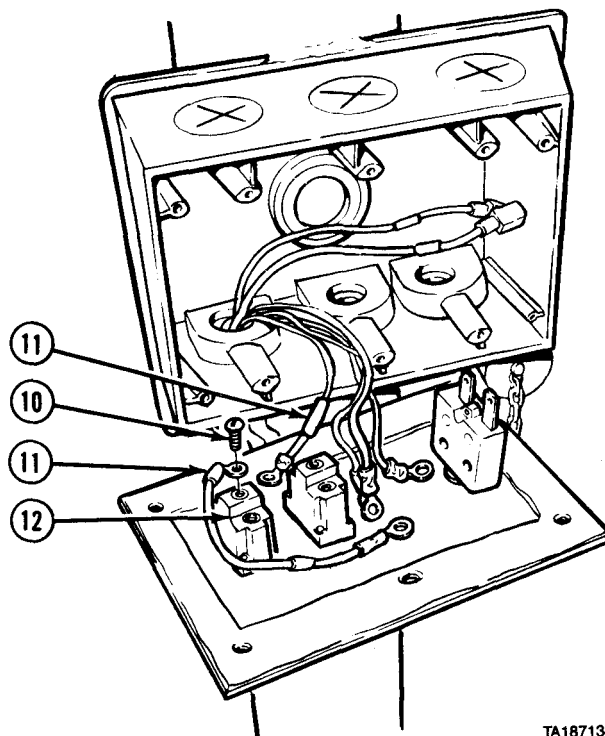
- (3) Disconnect two wires (5) from circuit breaker (6).
- (4) Remove three screws (7) and four wires (8) from ON/OFF switch (9).



TA187132

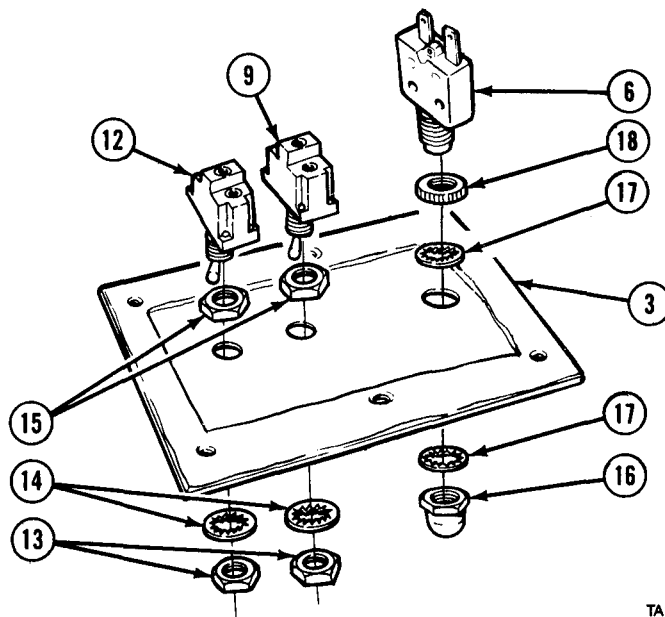
Electrical System Maintenance Instructions (Cont)

- (5) Remove two screws (10) and two wires (11) from LATCH switch (12).



TA187134

- (6) Remove two nuts (13) and lockwashers (14) from ON/OFF switch (9) and LATCH switch (12).
- (7) Remove two nuts (15) from ON/OFF switch (9) and LATCH switch (12).
- (8) Remove protective boot (16), two lockwashers (17), and circuit breaker (6) from cover (3).
- (9) Remove nut (18) from circuit breaker (6).

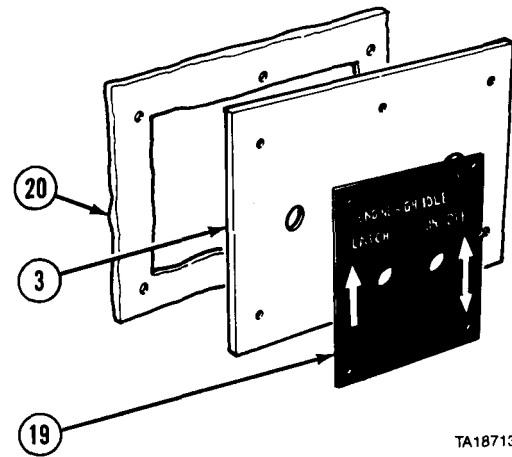


TA187135

Electrical System Maintenance Instructions (Cont)

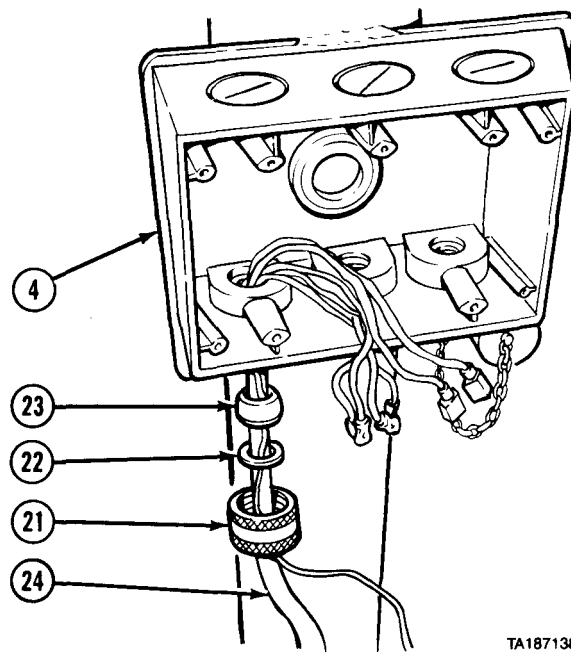
7-12. ENGINE HIGH IDLE BOX, CONNECTORS, AND SWITCHES REMOVAL/INSTALLATION (TIRE DAVIT MOUNTED) (M984, M985E1) (CONT).

- (10) Remove data plate (19) and gasket (20) from cover (3).



TA187137

- (11) Loosen nut (21) and slide ring (22) and grommet (23) down on harness (24).
- (12) Remove harness (24) from ENGINE HIGH IDLE box (4).



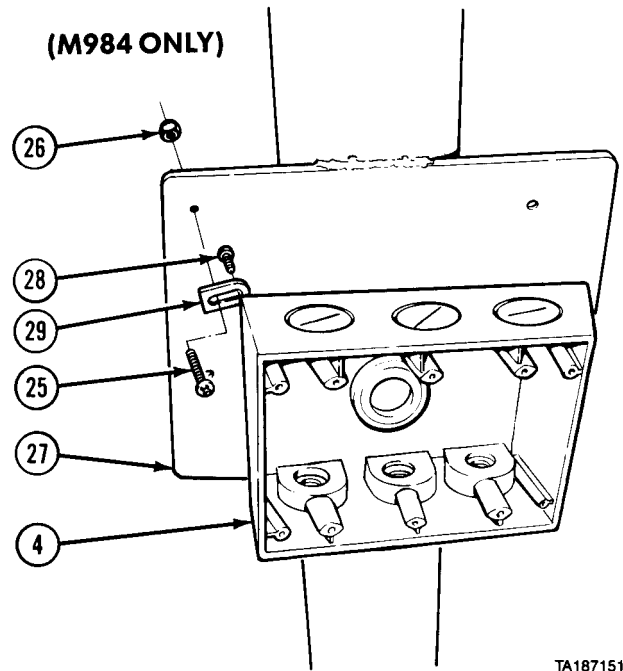
TA187138

Electrical System Maintenance Instructions (Cont)

NOTE

Do steps (13) and (14) for M984 vehicles only.

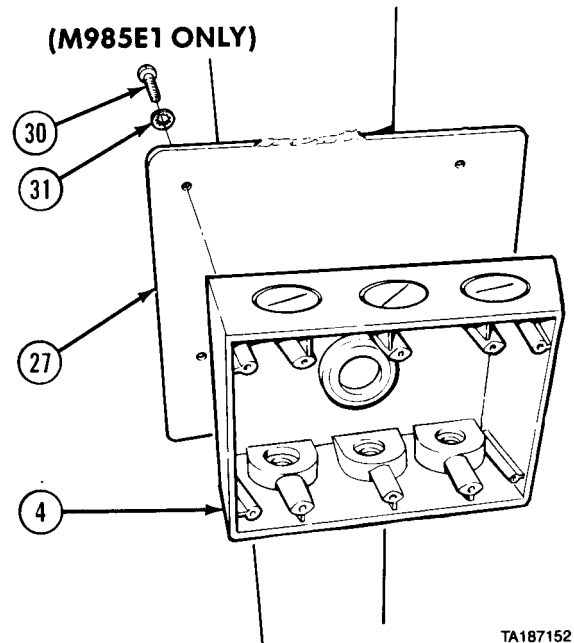
- (13) Remove four screws (25), locknuts (26), and ENGINE HIGH IDLE box (4) from tire davit (27).
- (14) Remove four screws (28) and clips (29) from ENGINE HIGH IDLE box (4).



NOTE

Do step (15) for M985E1 vehicles only.

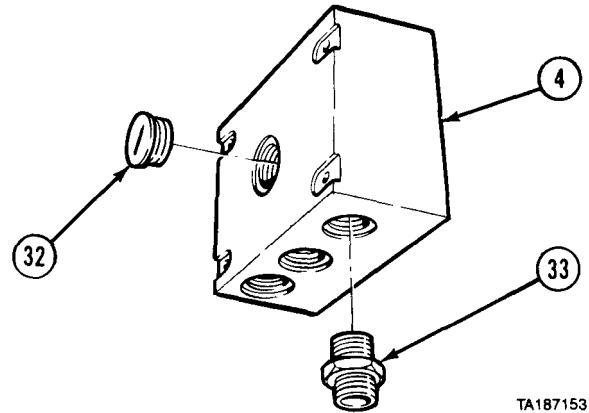
- (15) Remove four screws (30), lockwashers (31), and ENGINE HIGH IDLE box (4) from tire davit (27).



Electrical System Maintenance Instructions (Cont)

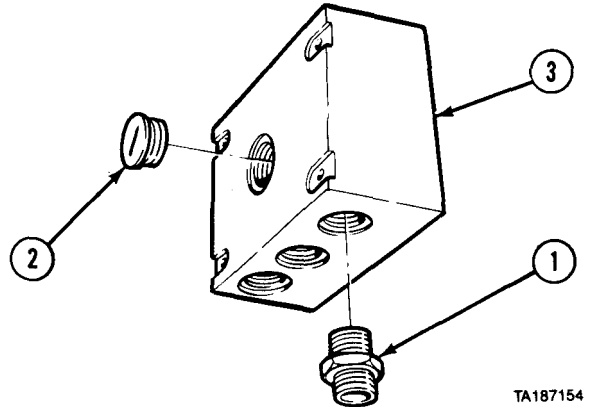
7-12. ENGINE HIGH IDLE BOX, CONNECTORS, AND SWITCHES REMOVAL/INSTALLATION (TIRE DAVIT MOUNTED) (M984, M985E1) (CONT).

(16) Remove six plugs (32) and fitting (33) from ENGINE HIGH IDLE box (4).



b. Installation.

(1) Install fitting (1) and six plugs (2) in ENGINE HIGH IDLE box (3).

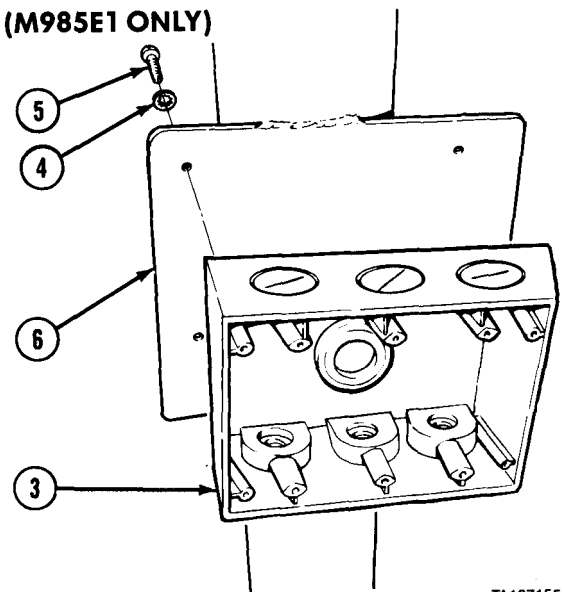


NOTE

Do step (2) for M985E1 vehicles only.

(2) Install ENGINE HIGH IDLE box (3) with four lockwashers (4) and screws (5) to tire davit (6).

(M985E1 ONLY)

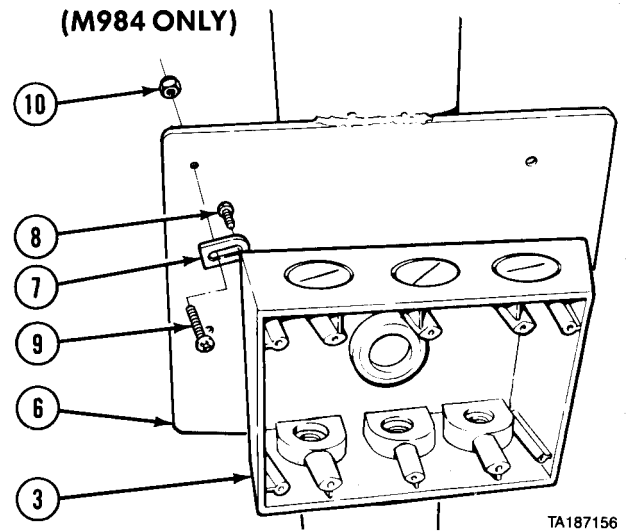


Electrical System Maintenance Instructions (Cont)

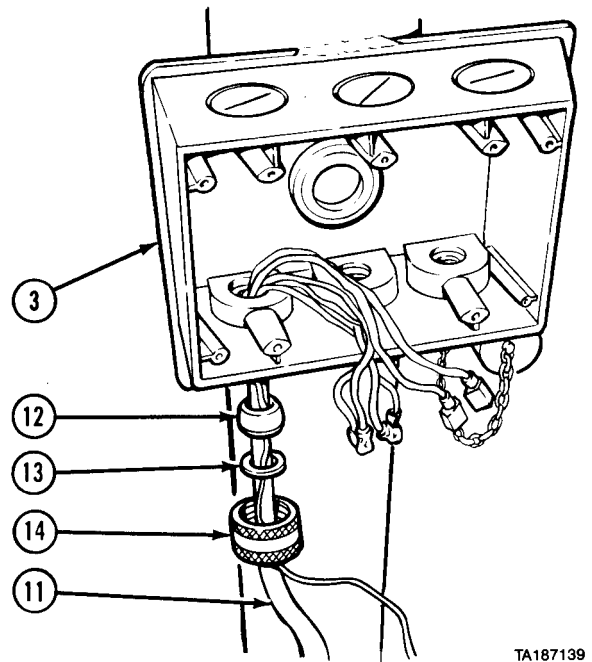
NOTE

Do steps (3) and (4) for M984 vehicles only.

- (3) Install four clips (7) with screws (8) to ENGINE HIGH IDLE box (3).
- (4) Install ENGINE HIGH IDLE box (3) with four screws (9) and locknuts (10) to tire davit (6).



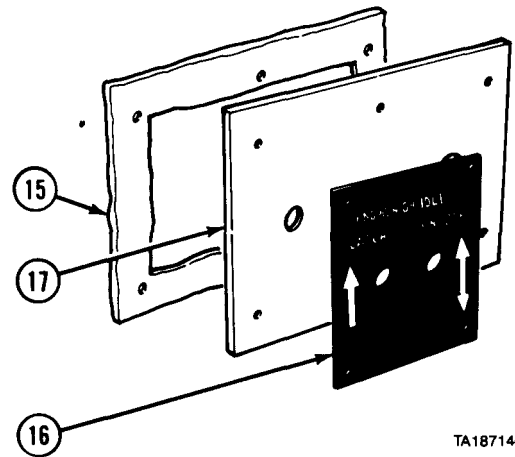
- (5) Install harness (11) in ENGINE HIGH IDLE box (3).
- (6) Install grommet (12), ring (13), and nut (14) on harness (11).



Electrical System Maintenance Instructions (Cont)

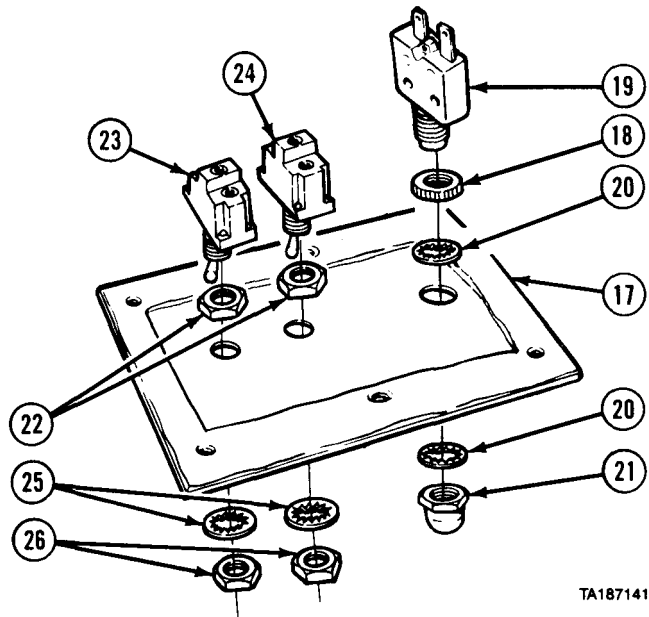
7-12. ENGINE HIGH IDLE BOX, CONNECTORS, AND SWITCHES REMOVAL/INSTALLATION (TIRE DAVIT MOUNTED) (M984, M985E1) (CONT).

- (7) Install gasket (15) and data plate (16) to cover (17).



TA187140

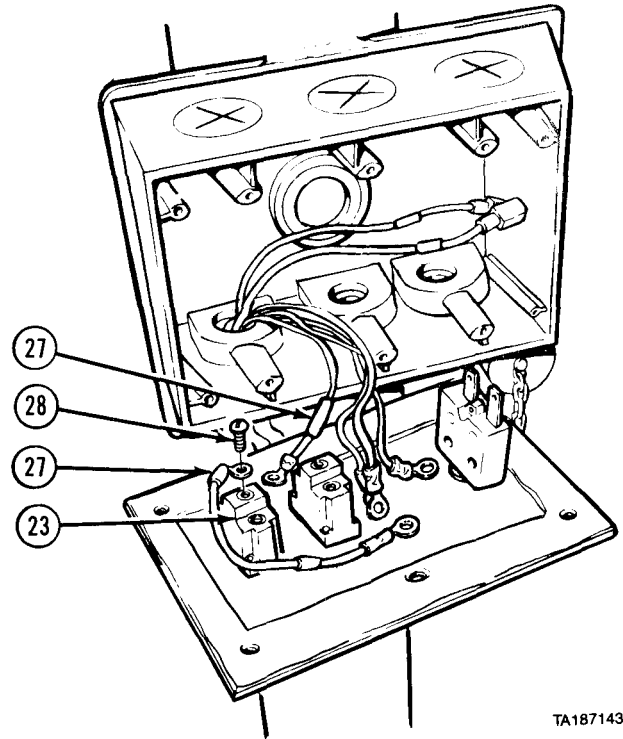
- (8) Install nut (18) on circuit breaker (19).
 (9) Install circuit breaker (19) in cover (17) with two lockwashers (20) and protective boot (21).
 (10) Install two nuts (22) on LATCH switch (23) and ON/OFF switch (24).
 (11) Install LATCH switch (23) and ON/OFF switch (24) in cover (17) with lockwashers (25) and nuts (26).



TA187141

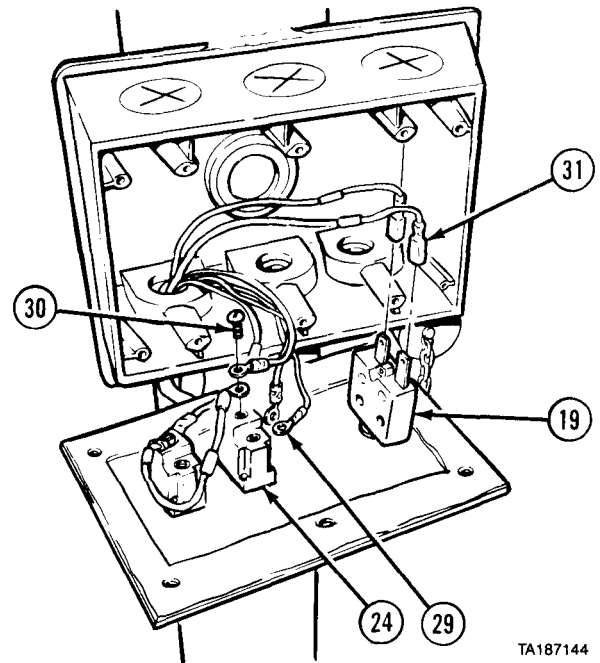
Electrical System Maintenance Instructions (Cont)

- (12) Install two wires (27) on LATCH switch (23) with two screws (28).



TA187143

- (13) Install four wires (29) on ON/OFF switch (24) with three screws (30).
 (14) Connect two wires (31) to circuit breaker (19).



TA187144

Electrical System Maintenance Instructions (Cont)

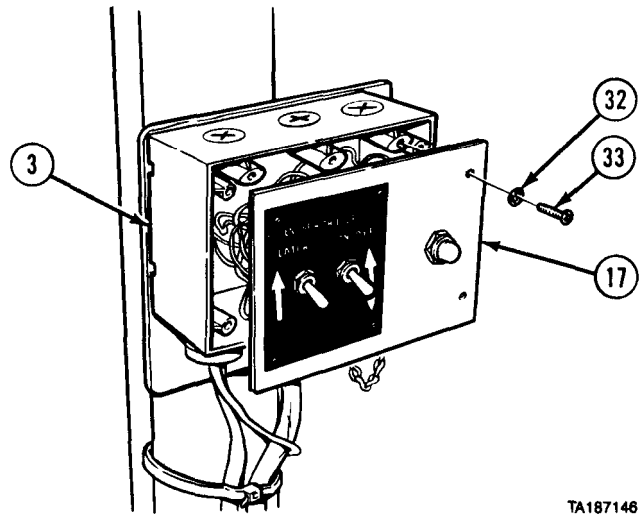
7-12. ENGINE HIGH IDLE BOX, CONNECTORS, AND SWITCHES REMOVAL/INSTALLATION (TIRE DAVIT MOUNTED) (M984, M985E1) (CONT).

(15) Install cover (17) to ENGINE HIGH IDLE box (3) with six lockwashers (32) and screws (33).

c. Follow-on Maintenance.

- (1) Connect batteries (para 7-91).
- (2) Check operation of ENGINE HIGH IDLE LATCH and ON/OFF switches (M984) (TM 9-2320-354-10), (M985E1) (TM 9-2320-355-10).

END OF TASK



TA187148

7-13. OIL MANIFOLD REMOVAL/INSTALLATION.

This task covers:

- a. Removal
- b. Installation
- c. Follow-on Maintenance

INITIAL SETUP

Models

All

Test Equipment

None

Special Tools

None

Supplies

Compound, sealing, pipe thread, Item 18, Appendix C

Personnel Required

MOS 63S, Heavy wheel vehicle mechanic

References

None

Equipment Condition

TM or Para

Para 7-83

Para 7-82

Para 7-84

Para 7-79

Condition Description

Oil manifold hose disconnected.

Hour meter oil pressure switch removed.

Oil pressure switch removed.

Oil pressure sending unit removed.

Special Environmental Conditions

None

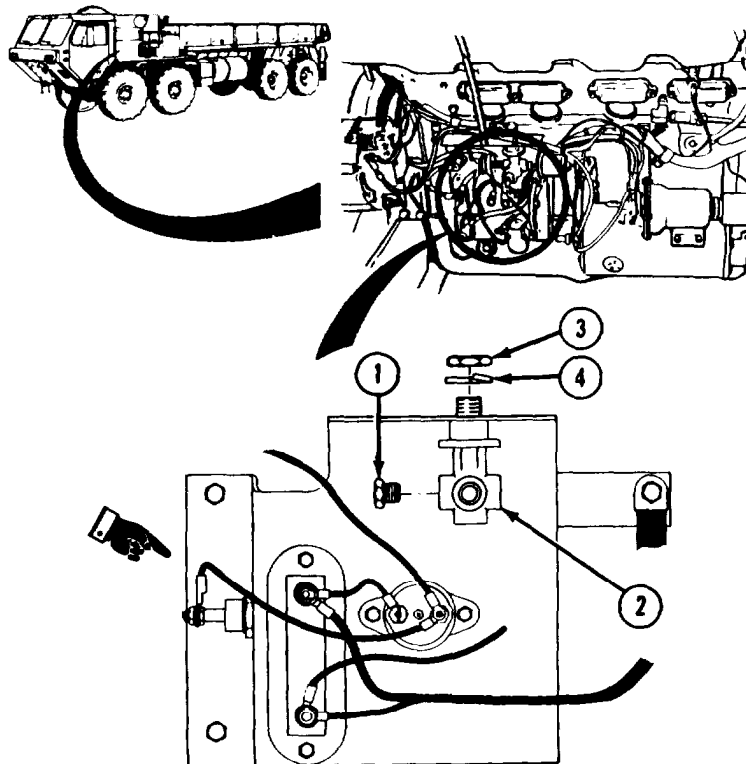
General Safety Instructions

None

Electrical System Maintenance Instructions (Cont)

a. **Removal**

- (1) Remove three reducer bushings from oil manifold (2).
- (2) Remove nut (3), lockwasher (4), and oil manifold (2).



Electrical System Maintenance Instructions (Cont)

7-13. OIL MANIFOLD REMOVAL/INSTALLATION (CONT).

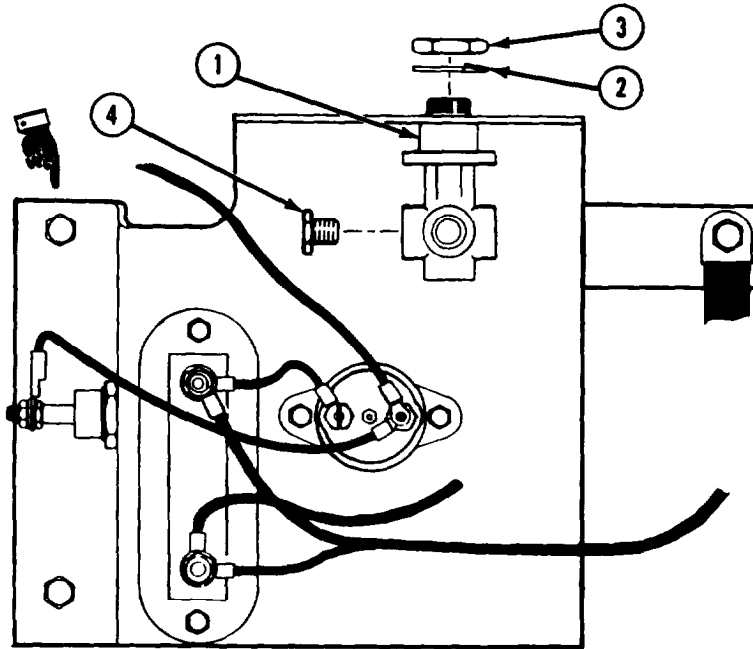
b. Installation

- (1) Install oil manifold (1) with lockwasher (2) and nut (3).

WARNING

Adhesives, solvents, and sealing compounds can burn easily, can give off harmful vapors, and are harmful to skin and clothing. To avoid injury or death, keep away from open fire and use in well-ventilated area. If adhesive, solvent, or sealing compound gets on skin or clothing, wash immediately with soap and water.

- (2) Coat threads of reducer bushings (4) with pipe thread sealing compound.
- (3) Install three reducer bushings (4) in oil manifold (1).



c. Follow-on Maintenance

- (1) Install oil pressure sending unit (para 7-79).
- (2) Install oil pressure switch (para 7-84).
- (3) Install hour meter oil pressure switch (para 7-82).
- (4) Connect oil manifold hose (para 7-83).

END OF TASK

Electrical System Maintenance Instructions (Cont)

7-14. ENGINE CIRCUIT BREAKER REMOVAL/INSTALLATION.

This task covers:

- a. Removal
- b. Installation
- c. Follow-on Maintenance

INITIAL SETUP

Models
All

Test Equipment
None

Special Tools
None

Supplies
Sealant, RTV200 Electrical, Item 45.05, Appendix C
Tags, identification, Item 48, Appendix C

Personnel Required
MOS 63S, Heavy wheel vehicle mechanic

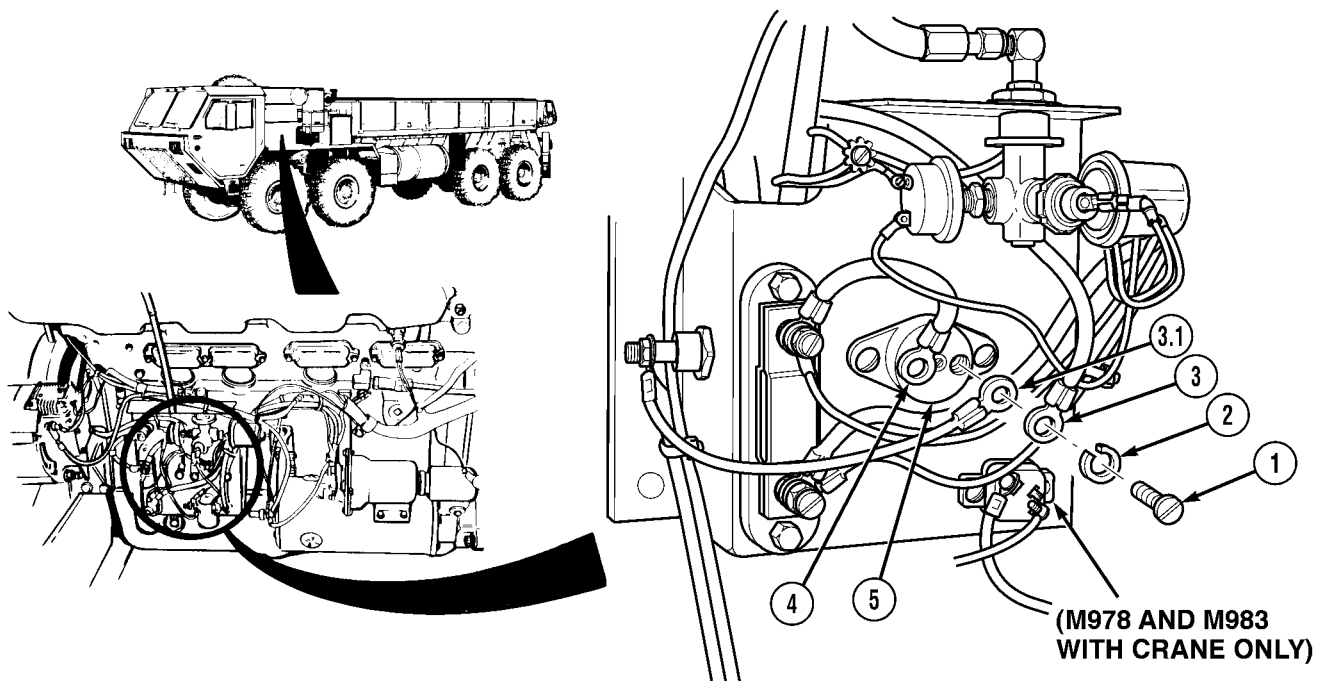
References
None

Equipment Condition
TM or Para *Condition Description*
TM 9-2320-279-10 Engine side panel removed.
Para 7-91 Batteries disconnected.

Special Environmental Conditions
None

General Safety Instructions
None

a. Removal.



NOTE

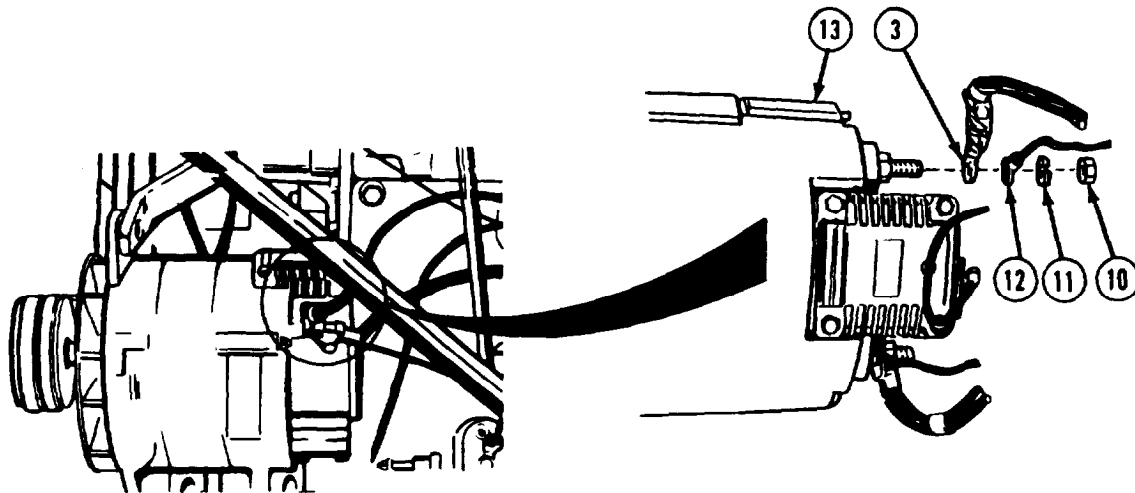
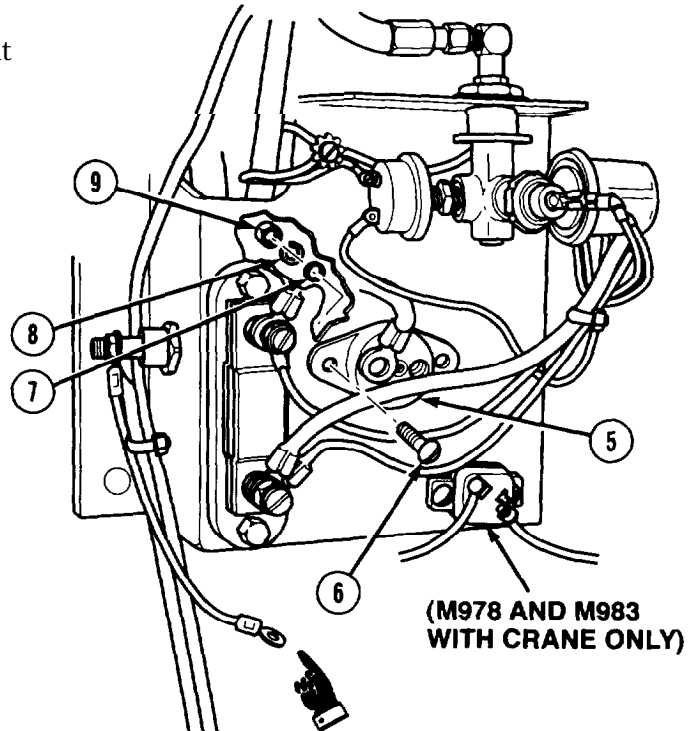
Tag and mark wires before removing.

- (1) Remove two screws (1), lockwashers (2), and wires (3, 3.1, and 4) from circuit breaker (5).

Electrical System Maintenance instructions (Cont)

7-14. ENGINE CIRCUIT BREAKER REMOVAL/INSTALLATION (CONT).

- (2) Remove two screws (6), washers (7) lockwashers (8), nuts (9), and circuit breaker (5).

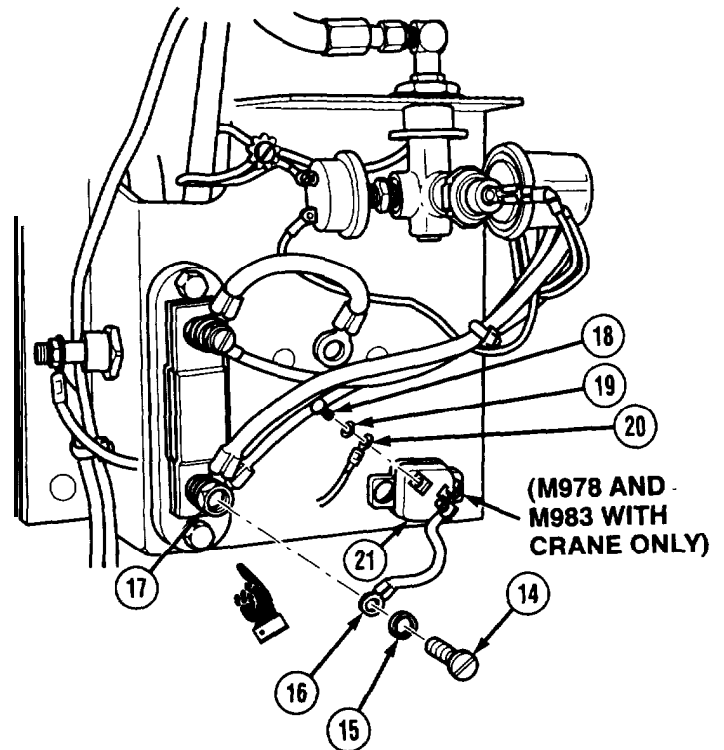


Electrical System Maintenance Instructions (Cont)

NOTE

Steps (4) through (6) are for M978 and M983 only.

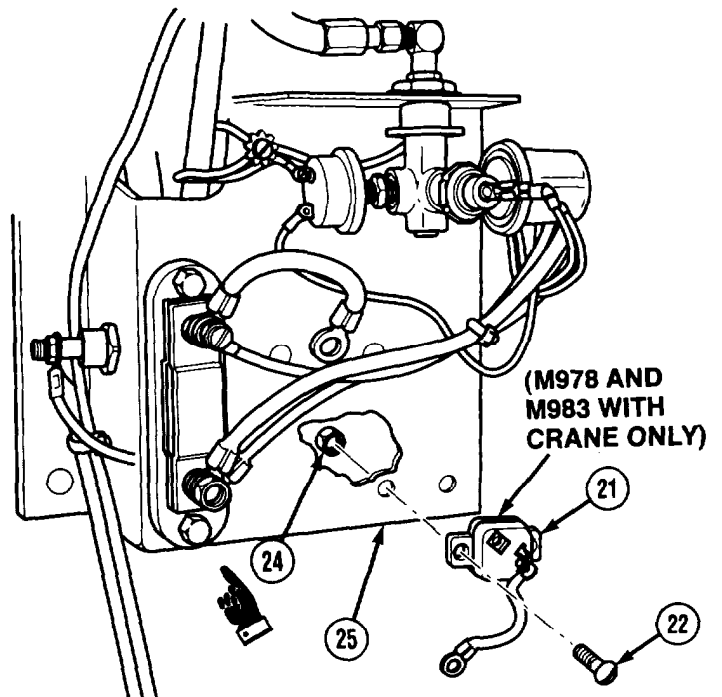
- (4) Remove screw (14) and lockwasher (15) to disconnect wire (16) from bus bar (17).
- (5) Remove screw (18) and lockwasher (19) to disconnect wire (20) from circuit breaker (21).



NOTE

Some vehicles have screws, lockwashers, and nuts. Others have screws and nuts.

- (6) Remove two screws (22), nuts (24), and circuit breaker (21) from sender mounting bracket (25).



Electrical System Maintenance Instructions (Cont)

7-14. ENGINE CIRCUIT BREAKER REMOVAL/INSTALLATION (CONT).

b. Installation.

NOTE

- Steps (1) through (3) are for M978 and M983 only.
 - Some vehicles have screws, lockwashers, and nuts. Others have screws and nuts.
- (1) Install circuit breaker (1) with two screws (2) and nuts (4).

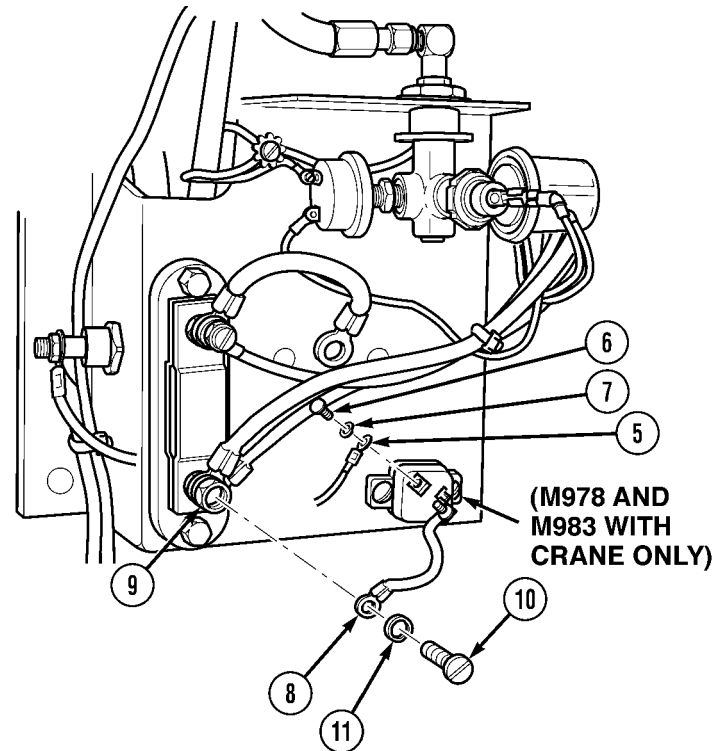
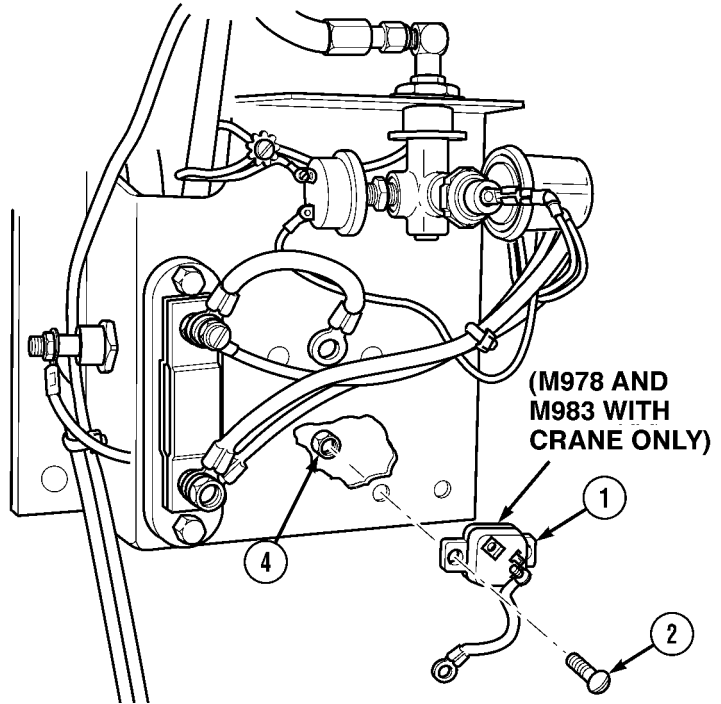
WARNING

Adhesives, solvents, and sealing compounds can burn easily, can give off harmful vapors, and are harmful to skin and clothing. To avoid injury or death, keep away from open fire and use in well-ventilated area. If adhesive, solvent, or sealing compound gets on skin or clothing, wash immediately with soap and water.

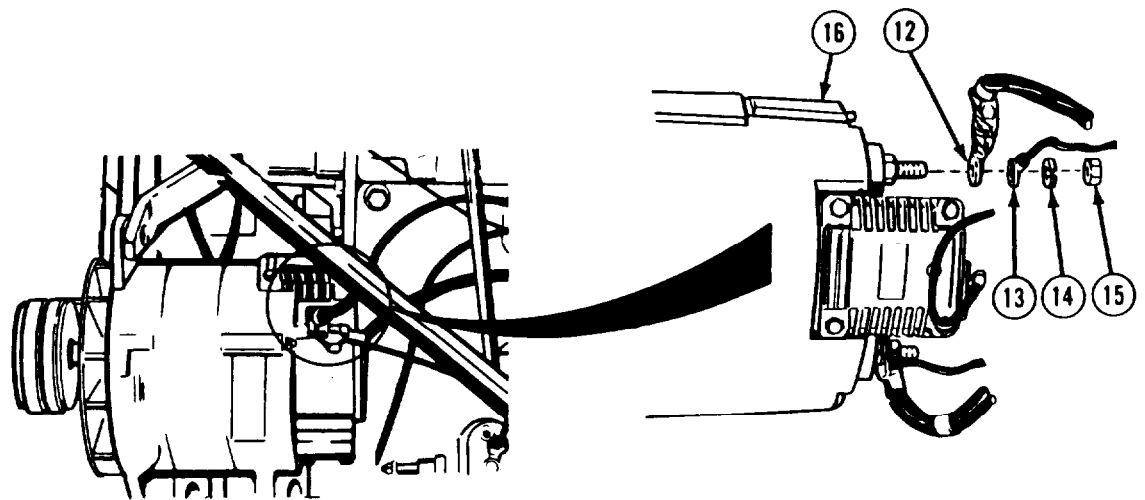
NOTE

Apply electrical sealant to exposed wire connectors after installing connectors.

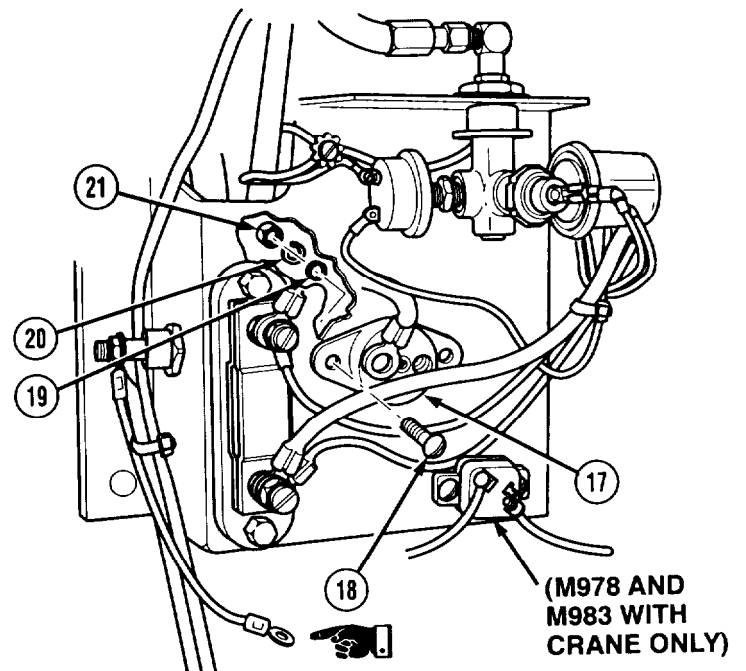
- (2) Connect wire (5) with screw (6) and lockwasher (7).
- (3) Connect wire (8) to bus bar (9) with screw (10) and lockwasher (11).



Electrical System Maintenance Instructions (Cont)



- (4) Install wire (12), wire (13), lockwasher (14), and nut (15) on positive terminal of alternator^F (16).
- (5) Install circuit breaker (17) with two screws (18), washers (19), lockwashers (20), and nuts (21).



Electrical System Maintenance Instructions (Cont)

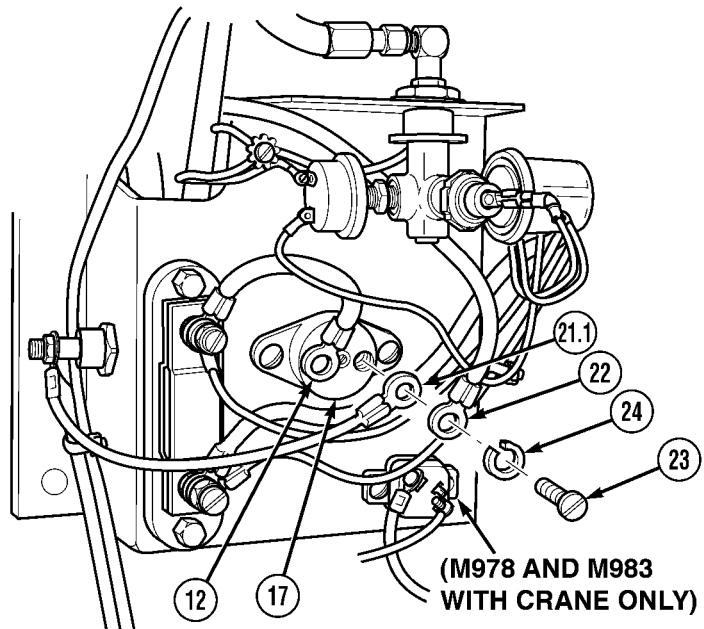
7-14. ENGINE CIRCUIT BREAKER REMOVAL/INSTALLATION (CONT).

- (6) Connect wires (12, 21.1, and 22) to circuit breaker (17) with two screws (23) and lockwashers (24).

c. Follow-on Maintenance.

- (1) Connect batteries (para 7-91).
- (2) Install engine side panel (TM 9-2320-279-10).

END OF TASK



7-15. BUS BAR REMOVAL/INSTALLATION.

This task covers:

- a. Removal
- b. Installation
- c. Follow-on Maintenance

INITIAL SETUP

Models

All

Test Equipment

None

Special Tools

None

Supplies

Sealant, RTV200 Electrical, Item 45.45, Appendix C
 Tags, identification, Item 48, Appendix C

Personnel Required

MOS 63S, Heavy wheel vehicle mechanic

References

None

Equipment Condition

| <i>TM or Para</i> | <i>Condition Description</i> |
|-------------------|------------------------------|
| TM 9-2320-279-10 | Engine side panel removed. |
| Para 7-19 | Batteries disconnected. |

Special Environmental Conditions

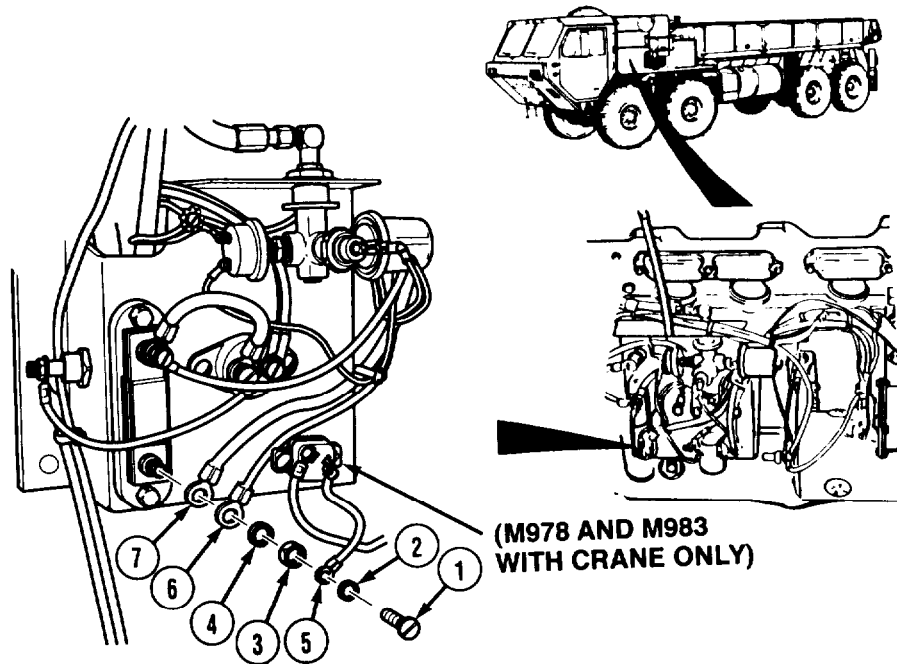
None

General Safety Instructions

None

Electrical System Maintenance Instructions (Cont)

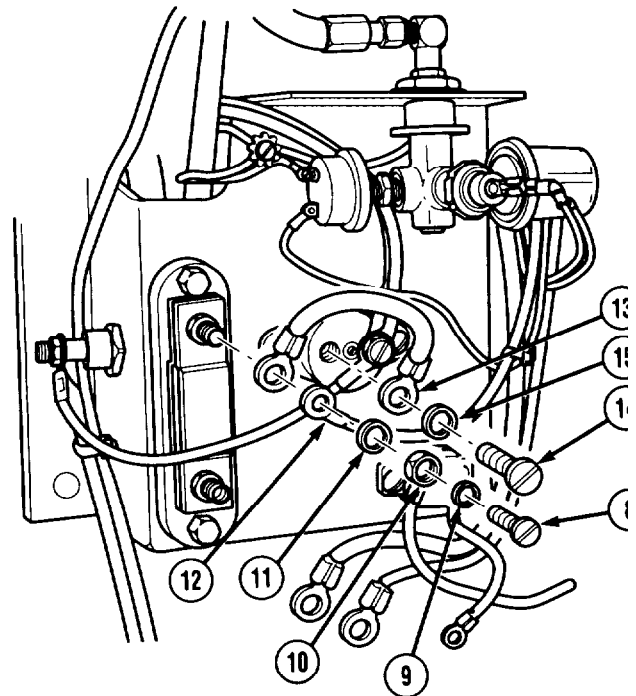
a. Removal.



NOTE

Tag and mark wires before removing.

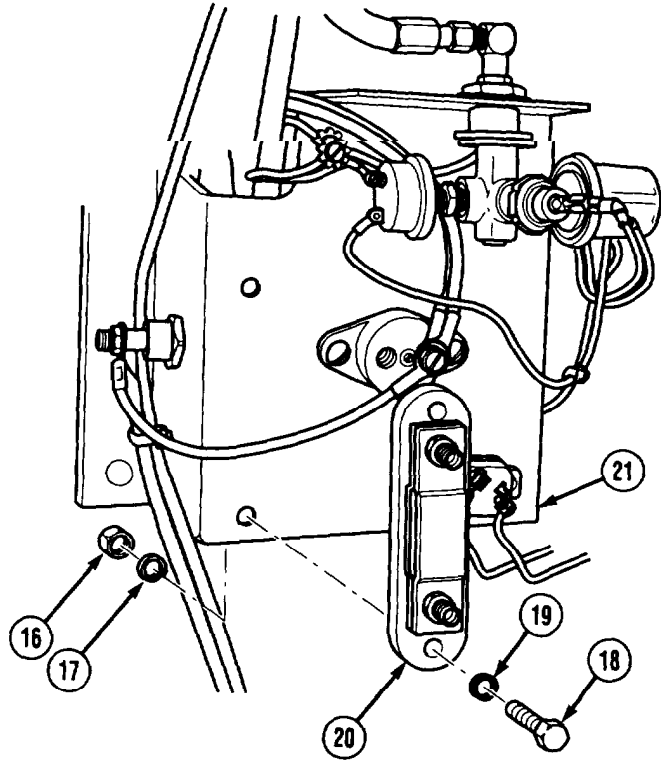
- (1) Remove screw (1), lockwasher (2), nut (3) lockwasher (4), and three wires (5,6, and 7).
- (2) Remove screw (8) lockwasher (9), nut (10) lockwasher (11), and two wires (12 and 13).
- (3) Remove screw (14), lockwasher (15), and wire (13).



Electrical System Maintenance Instructions (Cont)

7-15. BUS BAR REMOVAL/INSTALLATION (CONT).

- (4) Deleted.
- (5) Remove two nuts (16), lockwashers (17), screws (18), washers (19), and bus bar (20) from sender mounting bracket (21).



Electrical System Maintenance Instructions (Cont)

b. Installation.

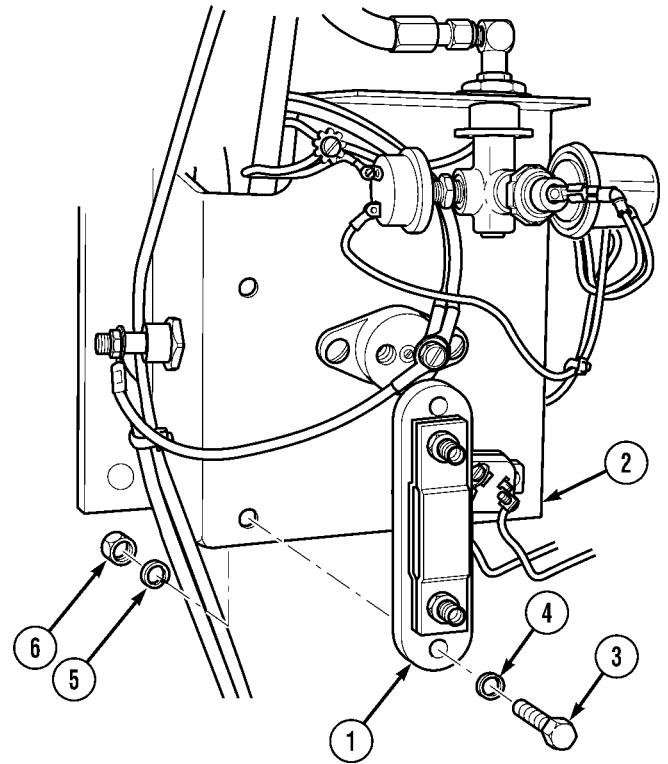
WARNING

Adhesives, solvents, and sealing compounds can burn easily, can give off harmful vapors, and are harmful to skin and clothing. To avoid injury or death, keep away from open fire and use in well-ventilated area. If adhesive, solvent, or sealing compound gets on skin or clothing, wash immediately with soap and water.

NOTE

Apply electrical sealant to exposed wire connectors after installing connectors.

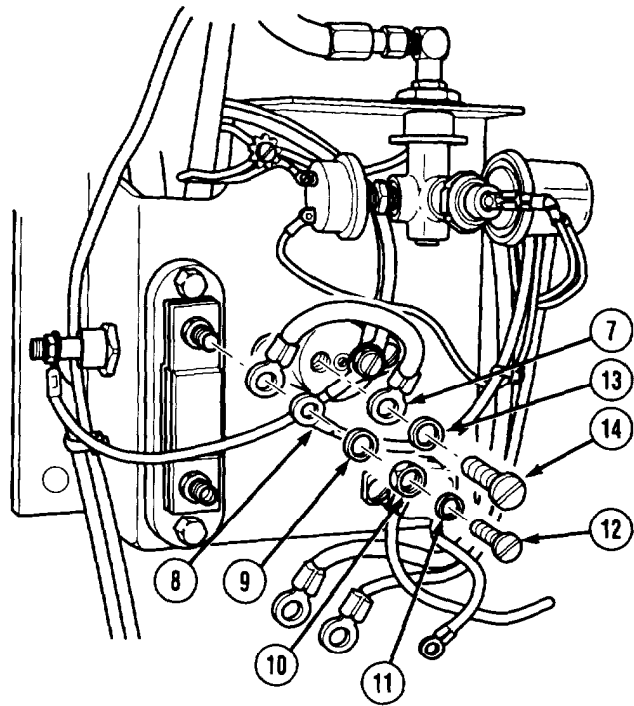
- (1) Install bus bar (1) on sender mounting bracket (2) with two screws (3), washers (4), lockwasher (5), and nuts (6).
- (2) Deleted.



Electrical System Maintenance Instructions (Cont)

7-15. BUS BAR REMOVAL/INSTALIATION (CONT).

- (3) Install two wires (7 and 8) with lockwasher (9), nut (10), lockwashers (11), and screw (12).
- (4) Install wire (7) with lockwasher (13) and screw (14).



NOTE

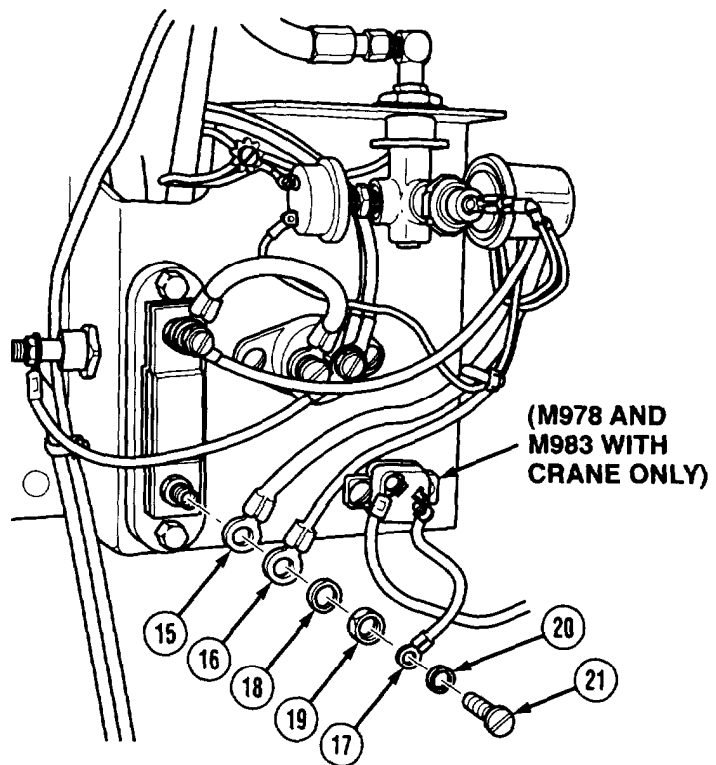
Wire (17) is on M983 with crane and M978.

- (5) Install three wires (15, 16, and 17) with lockwasher (18), nut (19), lockwasher (20), and screw (21).

c. Folio w-on Maintenance.

- (1) Install engine side panel (TM 9-2320-279-10).
- (2) Connect batteries (para 7-91).

END OF TASK

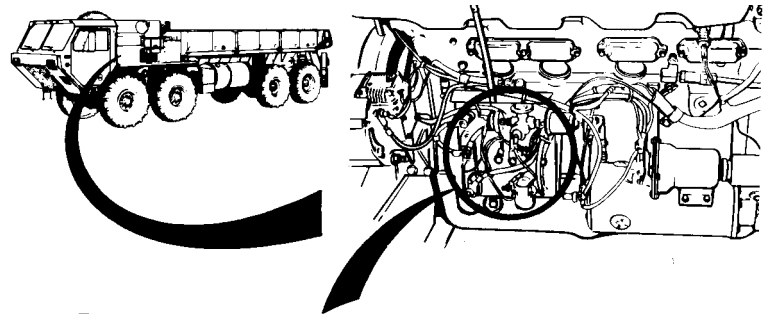


Electrical System Maintenance Instructions (Cont)

| | |
|--|----------------------------------|
| 7-16. DIODE REMOVAL/INSTALLATION. | |
| This task covers: | |
| a. Removal | c. Follow-on Maintenance |
| b. Installation | |
| INITIAL SETUP | |
| <i>Models</i> | <i>References</i> |
| All | None |
| <i>Test Equipment</i> | <i>Equipment Condition</i> |
| None | TM or Para |
| <i>Special Tools</i> | TM 9-2320-279-10 |
| None | Condition Description |
| <i>Supplies</i> | Para 7-91 |
| Sealant, RTV200 Electrical, Item 45.05, Appendix C | Engine side panel removed. |
| <i>Personnel Required</i> | Special Environmental Conditions |
| MOS 63S, Heavy wheel vehicle mechanic | None |
| | General Safety Instructions |
| | None |

a. Removal.

- (1) Remove nut (1), washer (2), and disconnect wire (3) from diode (4).
- (2) Remove nut (5), lockwasher (6), washer (7), and diode (4) from sender mounting bracket (8).



b. Installation.

- (1) Install diode (4) on bracket (8) with washer (7), lockwasher (6), and nut (5).

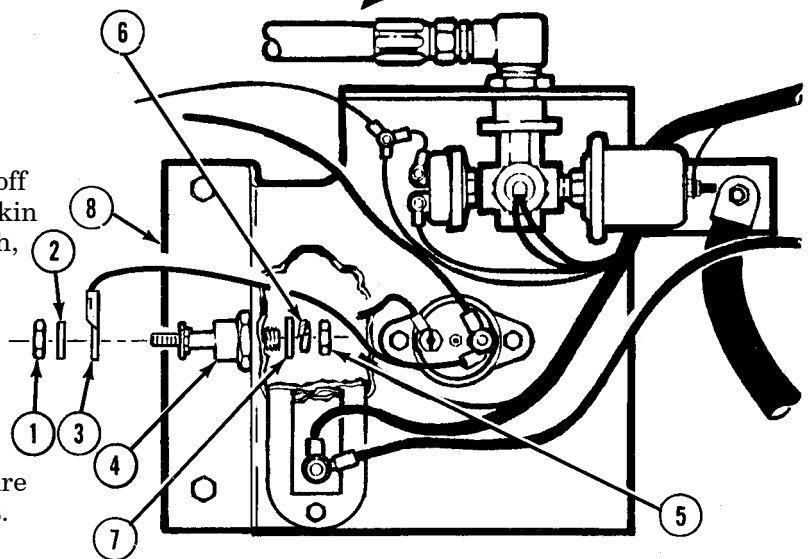
WARNING

Adhesives, solvents, and sealing compounds can burn easily, can give off harmful vapors, and are harmful to skin and clothing. To avoid injury or death, keep away from open fire and use in well-ventilated area. If adhesive, solvent, or sealing compound gets on skin or clothing, wash immediately with soap and water.

NOTE

Apply electrical sealant to exposed wire connectors after installing connectors.

- (2) Connect wire (3) to diode (4) with washer (2) and nut (1).



Electrical System Maintenance Instructions (Cont)

c. *Follow-on Maintenance.*

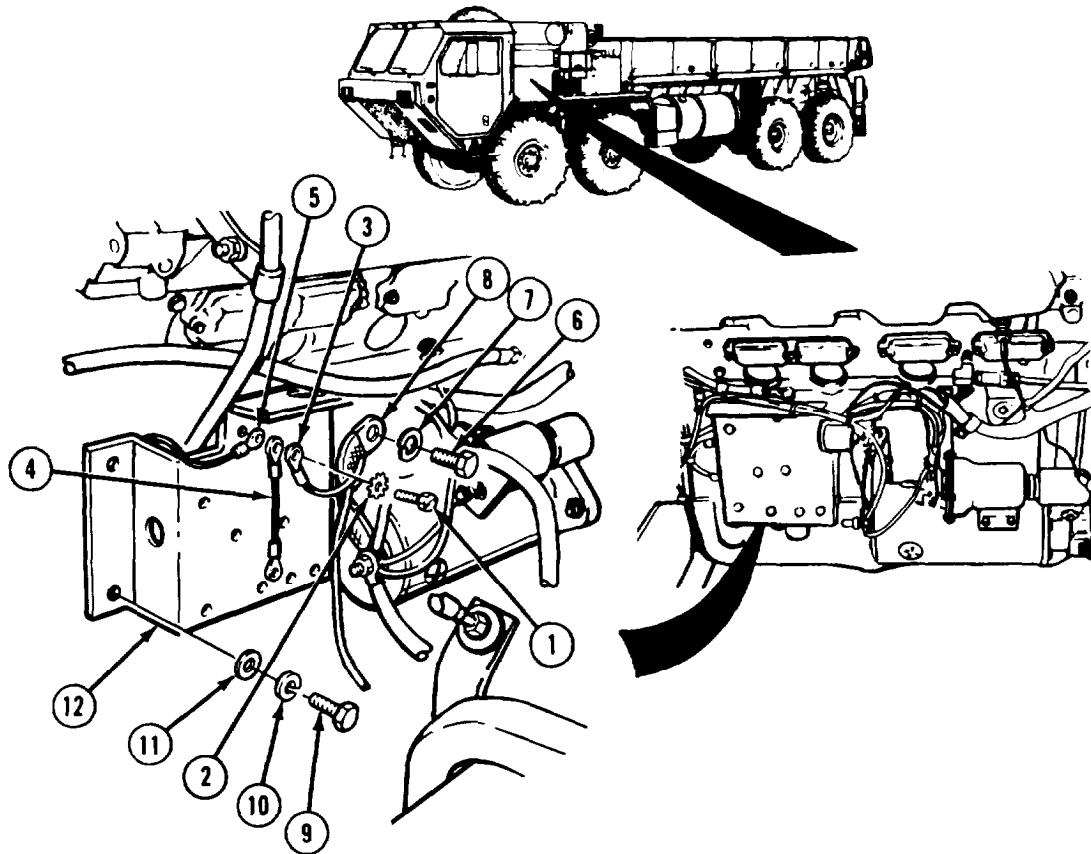
- (1) Connect batteries (para 7-91).
- (2) Install engine side panel (TM 9-2320-279-10).

END OF TASK

Electrical System Maintenance Instructions (Cont)

| | | |
|--|---|------------------------------|
| 7-17. SENDER MOUNTING BRACKET REMOVAL/INSTALLATION. | | |
| This task covers: | | |
| a. Removal | c. Follow-on Maintenance | |
| b. Installation | | |
| INITIAL SETUP | | |
| <i>Models</i> | <i>Equipment Condition</i> | |
| All | <i>TM or Para</i> | <i>Condition Description</i> |
| <i>Test Equipment</i> | Para 7-13 | Oil manifold removed. |
| None | Para 7-14 | Circuit breaker removed. |
| <i>Special Tools</i> | Para 7-15 | Bus bar removed. |
| None | Para 7- 16 | Diode removed. |
| <i>Supplies</i> | <i>Special Environmental Conditions</i> | |
| Tags, identification, Item 48. Appendix C | None | |
| <i>Personnel Required</i> | <i>General Safety Instructions</i> | |
| MOS 63S, Heavy wheel vehicle mechanic | None | |
| <i>References</i> | | |
| None | | |

Electrical System Maintenance Instructions (Cont)

a. **Removal.****NOTE**

Tag and mark wires before removing.

- (1) Remove screw (1), lockwashers (2), and disconnect three wires (3, 4, and 5).

NOTE

Some vehicles have two lockwashers (star-type). Others have one lockwasher (spring-type).

- (2) Remove screw (6), lockwasher (7), and ground strap (8).
- (3) Remove two screws (9), lockwashers (10), washers (11), and sender mounting bracket (12).

b. **Installation.**

- (1) Install sender mounting bracket (12) with two screws (9), washers (11), and lockwashers (10).

NOTE

Some vehicles have two lockwashers (star-type). Others have one lockwasher (spring-type).

- (2) Install ground strap (8) with lockwasher (7) and screw (6).
- (3) Connect three wires (5, 4, and 3) with lockwasher (2) and screw (1).

c. **Follow-on Maintenance.**

- (1) Install diode (para 7-16).
- (2) Install bus bar (para 7-15).
- (3) Install circuit breaker (para 7-14).
- (4) Install oil manifold (para 7-13).

END OF TASK

Electrical System Maintenance Instructions (Cont)

Section V. INSTRUMENT AND CONTROL PANELS

7-18. UTILITY OUTLET REMOVAL/INSTALLATION.

This task covers:

- a. Removal
- b. Installation
- c. Follow-on Maintenance

INITIAL SETUP

Models

All

References

None

Test Equipment

None

Equipment Condition

| | | |
|-------------------|------------------|--------------------|
| <i>TM or Para</i> | <i>Condition</i> | <i>Description</i> |
| Para 7-91 | Batteries | disconnected. |

Special Tools

None

Special Environment Conditions

None

Supplies

None

General Safety Instructions

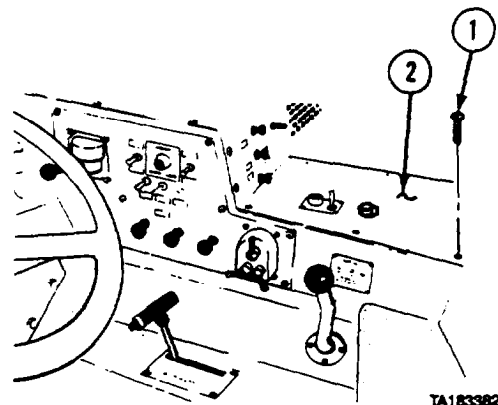
None

Personnel Required

MOS 63S. Heavy wheel vehicle mechanic

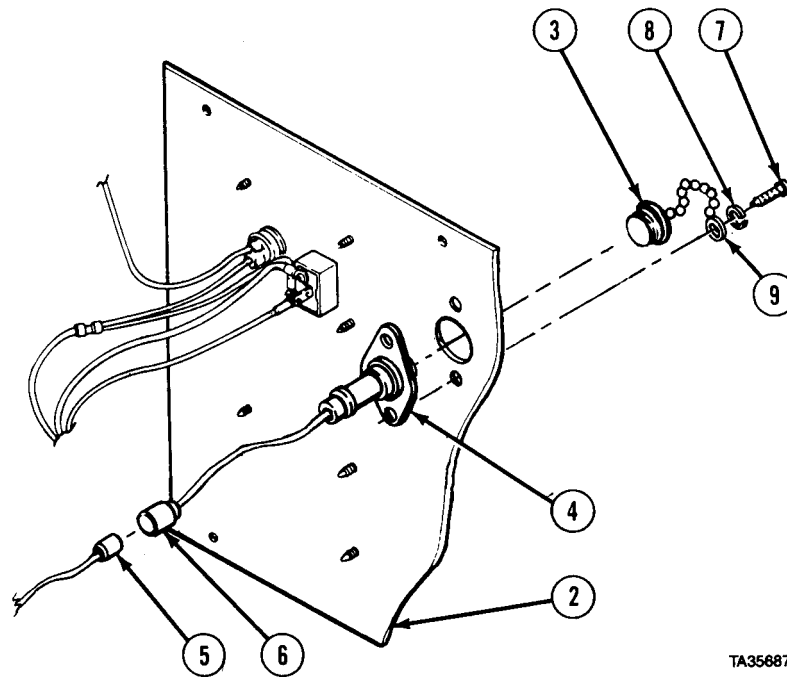
a. Removal.

- (1) Remove six screws (1) and heater compartment cover (2) from console.



TA183382

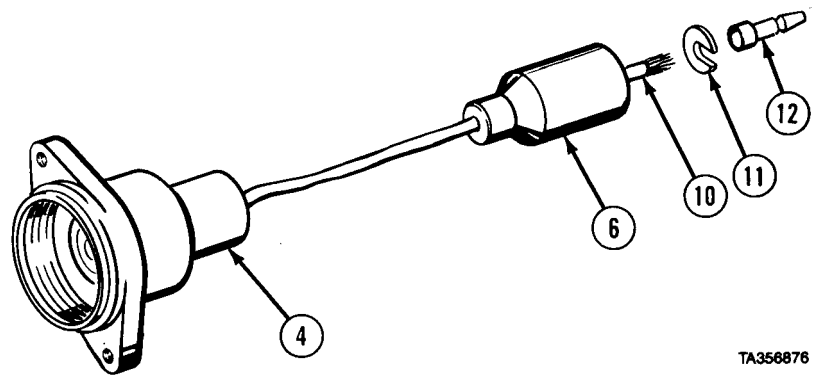
Electrical System Maintenance Instructions (Cont)



TA356875

- (2) Remove cover (3) from outlet (4).
- (3) Disconnect plug (5) from connector (6).
- (4) Remove two screws (7), lockwasher (8), chain (9), and outlet (4) from heater compartment cover (2).

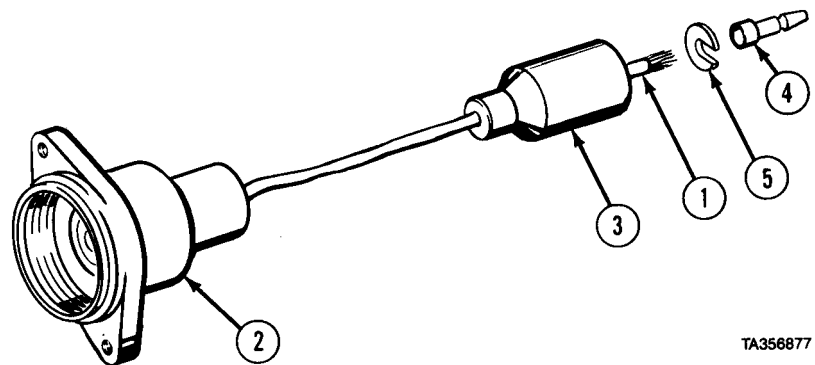
- (5) Push wire (10) through connector (6), remove C washer (11) and pin (12) from wire.
- (6) Remove wire (10) and connector (6) from outlet (4).



TA356876

b. Installation.

- (1) Install wire (1) in outlet (2) and connector (3).
- (2) Install pin (4) in wire (1).
- (3) Install wire (1) in connector (3) with C washer (5).

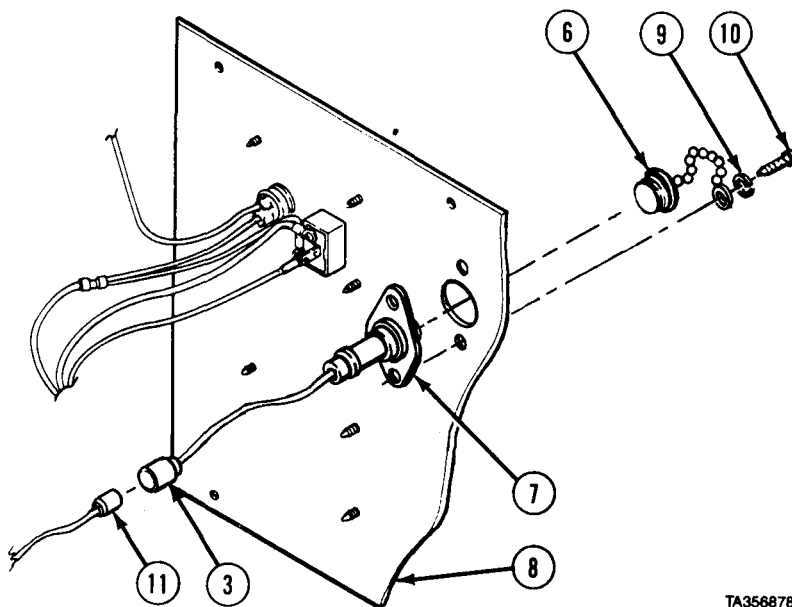


TA356877

Electrical System Maintenance Instructions (Cont)

7-18. UTILITY OUTLET REMOVAL/INSTALLATION (CONT).

- (4) Install cap and chain (6) and outlet (7) in heater compartment cover (8) with two lockwashers (9) and screws (10).
- (5) Install cap (6) on outlet (7).
- (6) Install plug (11) in connector (3).

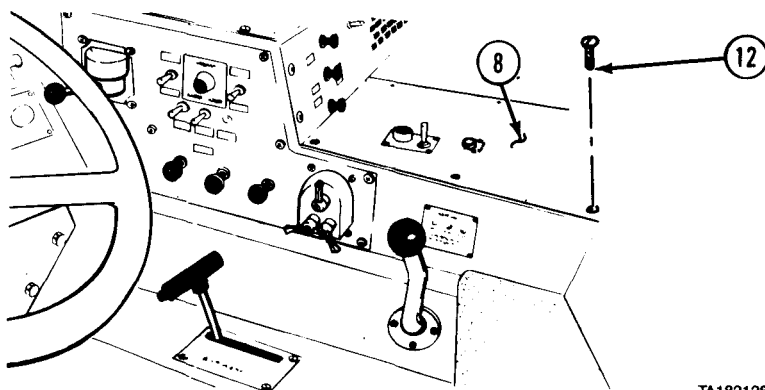


TA356878

- (7) Attach heater compartment cover (8) with six screws (12).

c. *Follow-on Maintenance.*

- (1) Connect batteries (para 7-91).
- (2) Plug in beacon light and check operation of utility outlet (TM 9-2320-279-10).



TA182128

END OF TASK

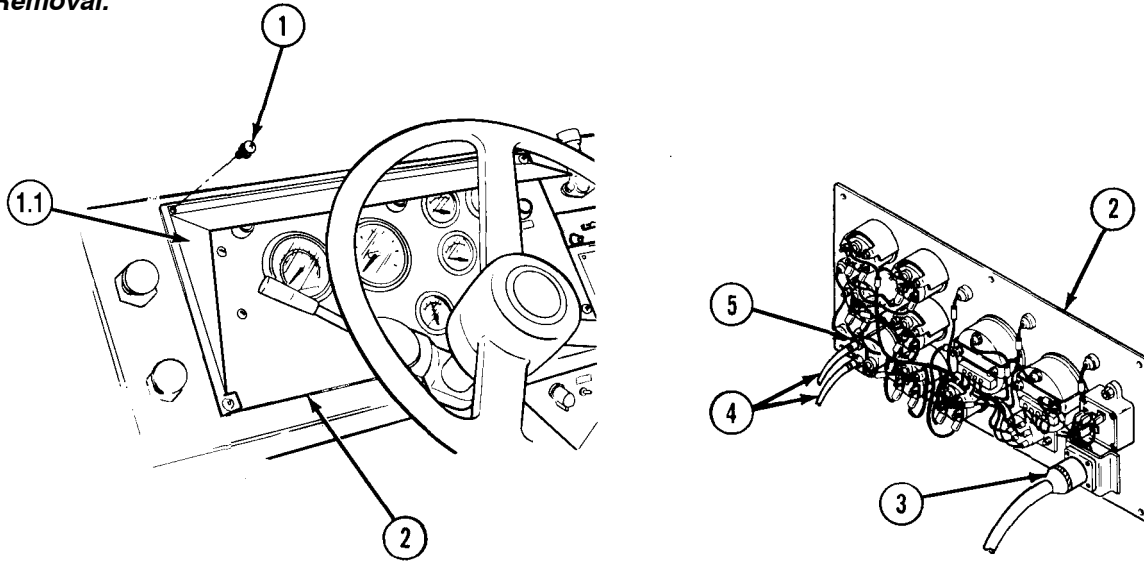
Electrical System Maintenance Instructions (Cont)

| | |
|--|--|
| 7-19. INSTRUMENT PANEL REMOVAL/INSTALLATION. | |
| This task covers: | |
| a. Removal b. Installation | c. Follow-on Maintenance |
| INITIAL SETUP | |
| <i>Models</i> All | <i>References</i> None |
| <i>Test Equipment</i> None | <i>Equipment Condition</i> |
| <i>Special Tools</i> None | <i>TM or Para</i> <i>Condition Description</i> TM 9-2320-279-10 Air system drained. Para 7-91 Batteries disconnected. |
| <i>Supplies</i> Tags, identification, Item 48, Appendix C | <i>Special Environmental Conditions</i> None |
| <i>Personnel Required</i> MOS 63S, Heavy wheel vehicle mechanic | <i>General Safety Instructions</i> None |

Electrical System Maintenance Instructions (Cont)

7-19. INSTRUMENT PANEL REMOVAL/INSTALLATION (CONT).

a. Removal.



- (1) Remove six screws (1) and sunshield (1.1) from instrument panel (2).
- (2) Lift instrument panel (2) to reach plug (3).
- (3) Disconnect cable connector (3) at rear of instrument panel (2).

NOTE

Tag and mark air lines before disconnecting.

- (4) Disconnect two air lines (4) from air pressure gage (5).
- (5) Remove instrument panel (2).

b. Installation.

- (1) Place instrument panel (2) inside cab.
- (2) Connect two air lines (4) to air pressure gage (5).
- (3) Connect cable connector (3) to instrument panel (2).
- (4) Position instrument panel (2) and install sunshield (1.1) and six screws (1).

c. Follow-on Maintenance.

- (1) Connect batteries (para 7-91).
- (2) Start engine and check operation of instrument panel gages, lights, and warning system indicators (TM 9-2320-279-10).
- (3) Shut off engine (TM 9-2320-279-10).

END OF TASK

Electrical System Maintenance Instructions (Cont)

7-20. OIL PRESSURE GAGE REMOVAL/INSTALLATION.

This task covers:

- a. Removal
- b. Installation
- c. Follow-on Maintenance

INITIAL SETUP

Models

All

Test Equipment

None

Special Tools

None

Supplies

Tags, identification, Item 48, Appendix C

Personnel Required

MOS 63S, Heavy wheel vehicle mechanic

References

None

Equipment Condition

TM or Para

Para 7-19

Condition Description

Instrument panel removed.

Special Environmental Conditions

None

General Safety Instructions

None

a. Removal.

- (1) Pull light socket (1) from oil pressure gage (2).

NOTE

Tag and mark wires before disconnecting.

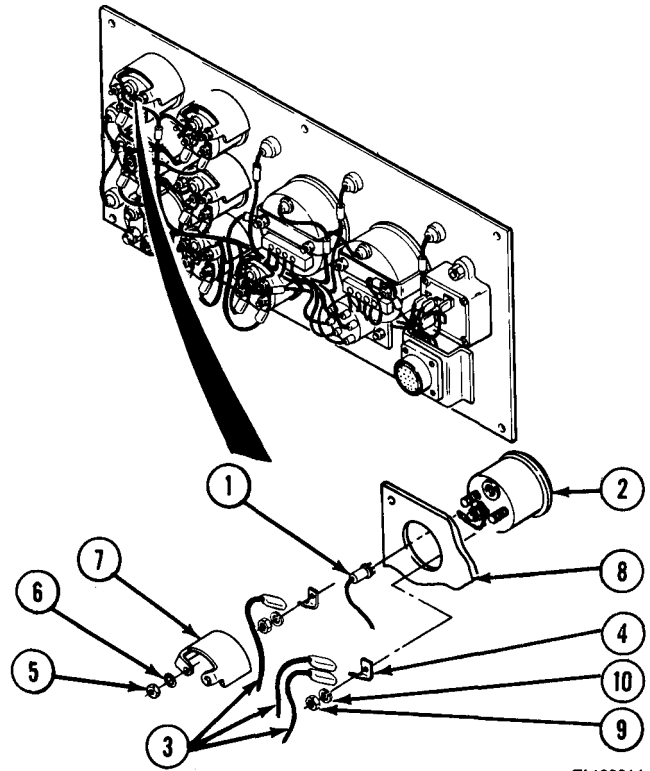
- (2) Disconnect three wires (3) from terminals (4).
- (3) Remove two nuts (5), lockwashers (6), and bracket (7).
- (4) Pull oil pressure gage (2) from instrument panel (8).
- (5) Remove three nuts (9), lockwashers (10), and terminals (4) from oil pressure gage (2).

b. Installation.

- (1) Install three terminals (4), lockwashers (10), and nuts (9) on oil pressure gage (2).
- (2) Install oil pressure gage (2) and bracket (7) on instrument panel (8) with two nuts (5), and lockwashers (6).
- (3) Connect three wires (3) to oil pressure gage (2).
- (4) Push light socket (1) in oil pressure gage (2).

c. Follow-on Maintenance.

- (1) Install instrument panel (para 7-19).
- (2) Start engine and check operation of oil pressure gage (TM 9-2320-279-10).
- (3) Shut off engine (TM 9-2320-279-10).



TA183814

END OF TASK

Electrical System Maintenance Instructions (Cont)

| | |
|--|--|
| 7-21. WATER TEMPERATURE GAGE REMOVAL/INSTALLATION. | |
| This task covers: | |
| a. Removal | c. Follow-on Maintenance |
| b. Installation | |
| INITIAL SETUP | |
| <i>Models</i> | <i>References</i> |
| All | None |
| <i>Test Equipment</i> | <i>Equipment Condition</i> |
| None | <i>TM or Para</i> <i>Condition Description</i> |
| <i>Special Tools</i> | Para 7-19 Instrument panel removed. |
| None | <i>Special Environmental Conditions</i> |
| <i>Supplies</i> | None |
| Tags, identification, Item 48, Appendix C | <i>General Safety Instructions</i> |
| <i>Personnel Required</i> | None |
| MOS 63S, Heavy wheel vehicle mechanic | |

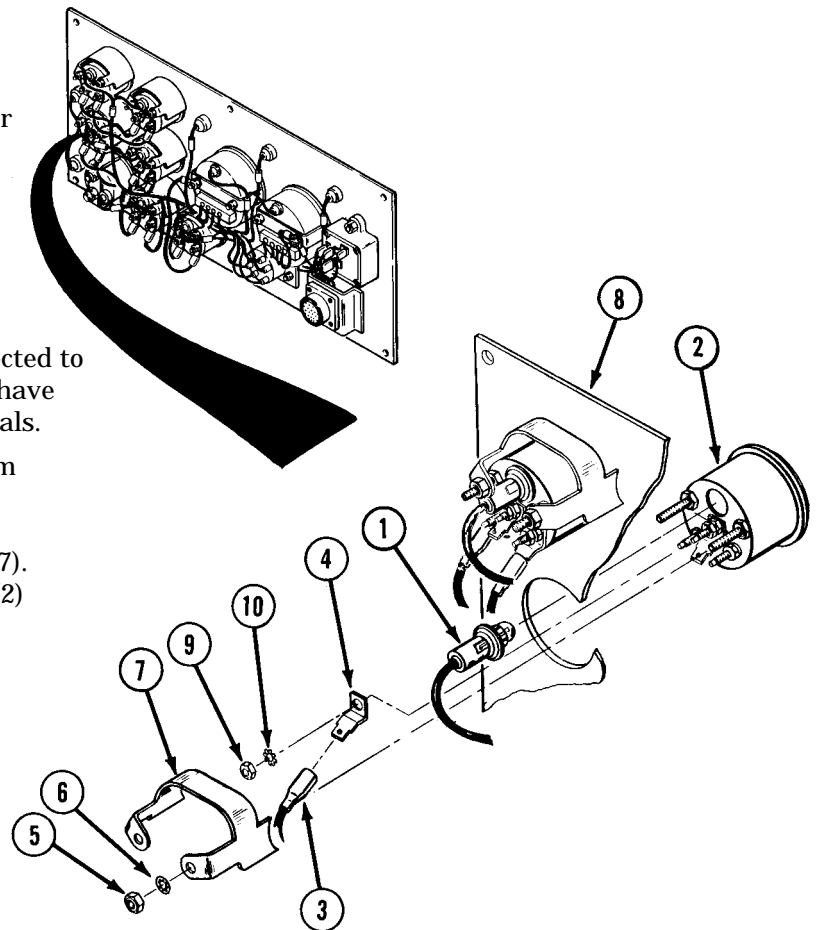
Electrical System Maintenance Instructions (Cont)

a. *Removal.*

- (1) Pull light socket (1) from water temperature gage (2).

NOTE

- Tag and mark wires before disconnecting.
 - Some trucks have wires connected to three terminals. Some trucks have wires connected to two terminals.
- (2) Disconnect three wires (3) from terminals (4).
 - (3) Remove two nuts (5), lockwashers (6), and bracket (7).
 - (4) Pull water temperature gage (2) from instrument panel (8).
 - (5) Remove three nuts (9), lockwashers (10), and three terminals (4) from water temperature gage (2).

b. *Installation.*

- (1) Install three terminals (4), three lockwashers (10), and nuts (9) on water temperature gage (2).
- (2) Install water temperature gage (2) and bracket (7) in instrument panel (8).
- (3) Install two nuts (5) and lockwashers (6) to secure water temperature gage (2) and bracket (7) on instrument panel (8).
- (4) Connect three wires (3) to water temperature gage (2).
- (5) Push light socket (1) into back of water temperature gage (2).

c. *Follow-on Maintenance.*

- (1) Install instrument panel (para 7-19).
- (2) Start engine and check operation of water temperature gage (TM 9-2320-279-10).
- (3) Shut off engine (TM 9-2320-279-10).

END OF TASK

Electrical System Maintenance Instructions (Cont)

| | | |
|---|---|------------------------------|
| 7-22. TRANSMISSION OIL TEMPERATURE GAGE REMOVAL/INSTALLATION. | | |
| This task covers: | | |
| a. Removal | c. Follow-on Maintenance | |
| b. Installation | | |
| INITIAL SETUP | | |
| <i>Models</i> | <i>References</i> | |
| All | None | |
| <i>Test Equipment</i> | <i>Equipment Condition</i> | |
| None | <i>TM or Para</i> | <i>Condition Description</i> |
| <i>Special Tools</i> | Para 7-19 | Instrument panel removed. |
| None | <i>Special Environmental Conditions</i> | |
| <i>Supplies</i> | None | |
| Tags, identification, Item 48, Appendix C | <i>General Safety Instructions</i> | |
| <i>Personnel Required</i> | None | |
| MOS 63S, Heavy wheel vehicle mechanic | | |

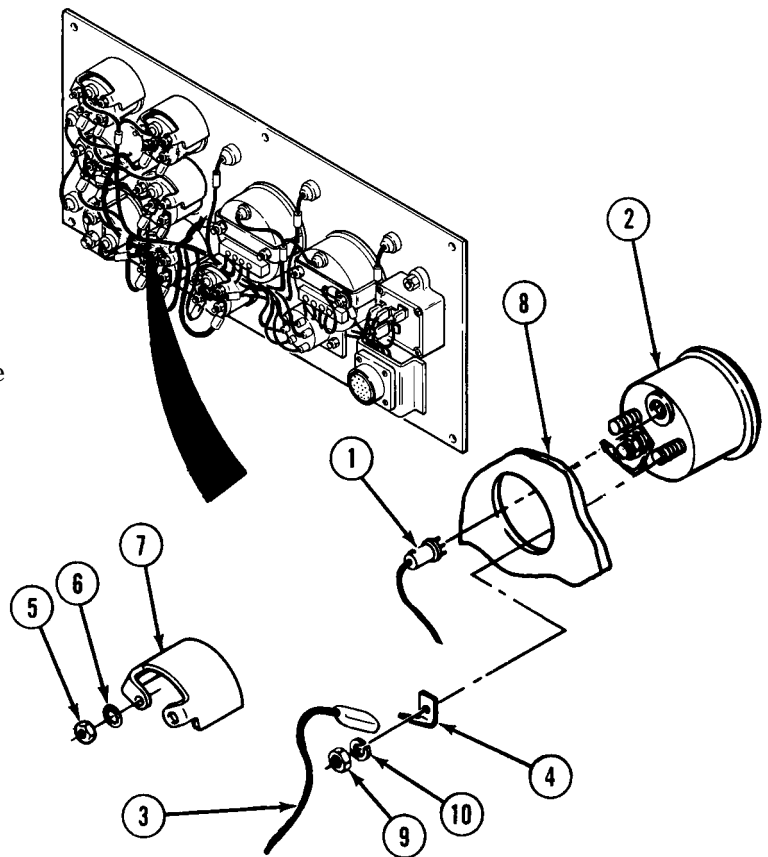
Electrical System Maintenance Instructions (Cont)

a. Removal.

- (1) Pull light socket (1) from transmission oil temperature gage (2).

NOTE

- Tag and mark wires before disconnecting.
 - Some trucks have two wires. Some trucks have three.
- (2) Disconnect three wires (3) from terminals (4).
 - (3) Remove two nuts (5), lockwashers (6), and bracket (7).
 - (4) Pull transmission oil temperature gage (2) from instrument panel (8).
 - (5) Remove three nuts (9), lockwashers (10), and three terminals (4) from transmission oil temperature gage (2).

**b. Installation.**

- (1) Install three terminals (4), three lockwashers (10), and nuts (9) on transmission oil temperature gage (2).
- (2) Install transmission oil temperature gage (2) and bracket (7) on instrument panel (8).
- (3) Install two nuts (5) and lockwashers (6) to secure transmission oil temperature gage (2) and bracket (7) on instrument panel (8).
- (4) Connect three wires (3) to terminals (4).
- (5) Push light socket (1) in transmission oil temperature gage (2).

c. Follow-on Maintenance.

- (1) Install instrument panel (para 7-19).
- (2) Start engine and check operation of transmission oil temperature gage (TM 9-2320-279-10).
- (3) Shut off engine (TM 9-2320-279-10).

END OF TASK

Electrical System Maintenance Instructions (Cont)

| | | |
|---|---|------------------------------|
| 7-23. FUEL GAGE REMOVAL/INSTALLATION. | | |
| This task covers: | | |
| a. Removal | c. Follow-on Maintenance | |
| b. Installation | | |
| INITIAL SETUP | | |
| <i>Models</i> | <i>References</i> | |
| All | None | |
| <i>Test Equipment</i> | <i>Equipment Condition</i> | |
| None | <i>TM or Para</i> | <i>Condition Description</i> |
| <i>Special Tools</i> | Para 7-19 | Instrument panel removed. |
| None | <i>Special Environmental Conditions</i> | |
| <i>Supplies</i> | None | |
| Tags, identification, Item 48, Appendix C | <i>General Safety Instructions</i> | |
| <i>Personnel Required</i> | None | |
| MOS 63S, Heavy wheel vehicle mechanic | | |

Electrical System Maintenance Instructions (Cont)

a. *Removal.*

- (1) Pull light socket (1) from fuel gage (2).

NOTE

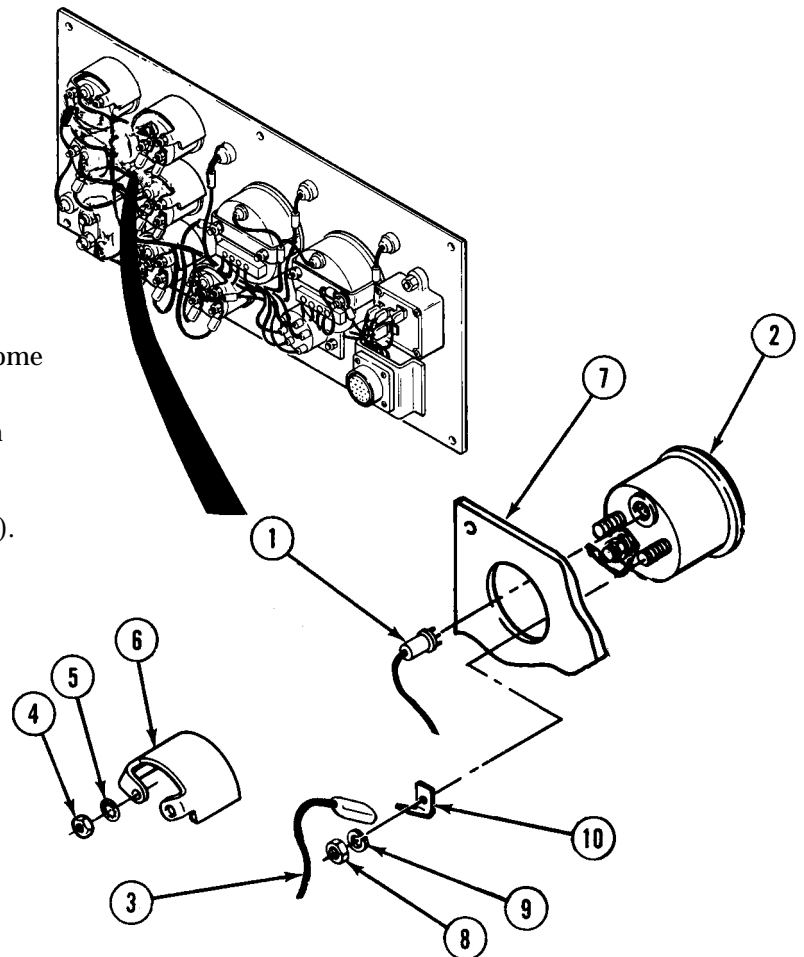
- Tag and mark wires before disconnecting.
 - Some trucks have two wires. Some trucks have three.
- (2) Disconnect three wires (3) from fuel gage (2).
 - (3) Remove two nuts (4), lockwashers (5), and bracket (6).
 - (4) Pull fuel gage (2) from instrument panel (7).
 - (5) Remove three nuts (8), lockwashers (9), and terminals (10) from fuel gage (2).

b. *Installation.*

- (1) Install three terminals (10), lockwashers (9), and nuts (8) on fuel gage (2).
- (2) Install fuel gage (2) and bracket (6) on instrument panel (7).
- (3) Install two nuts (4) and lockwashers (5) to secure fuel gage (2) and bracket (6) on instrument panel (7).
- (4) Connect three wires (3) to fuel gage (2).
- (5) Push light socket (1) in fuel gage (2).

c. *Follow-on Maintenance.*

- (1) Install instrument panel (para 7-19).
- (2) Check operation of fuel gage (TM 9-2320-279-10).



END OF TASK

Electrical System Maintenance Instructions (Cont)

7-24. VOLTMETER REMOVAL/INSTALLATION.

This task covers:

- a. Removal
- b. Installation
- c. Follow-on Maintenance

INITIAL SETUP

Models

All

References

None

Test Equipment

None

Equipment Condition

TM or Para

Condition Description

Special Tools

None

Para 7-19

Instrument panel removed.

Supplies

Tags, identification, Item 48, Appendix C

Special Environmental Conditions

None

Personnel Required

MOS 63S, Heavy wheel vehicle mechanic

General Safety Instructions

None

Electrical System Maintenance Instructions (Cont)

a. Removal.

- (1) Pull light socket (1) from voltmeter (2).

NOTE

Tag and mark wires before disconnecting.

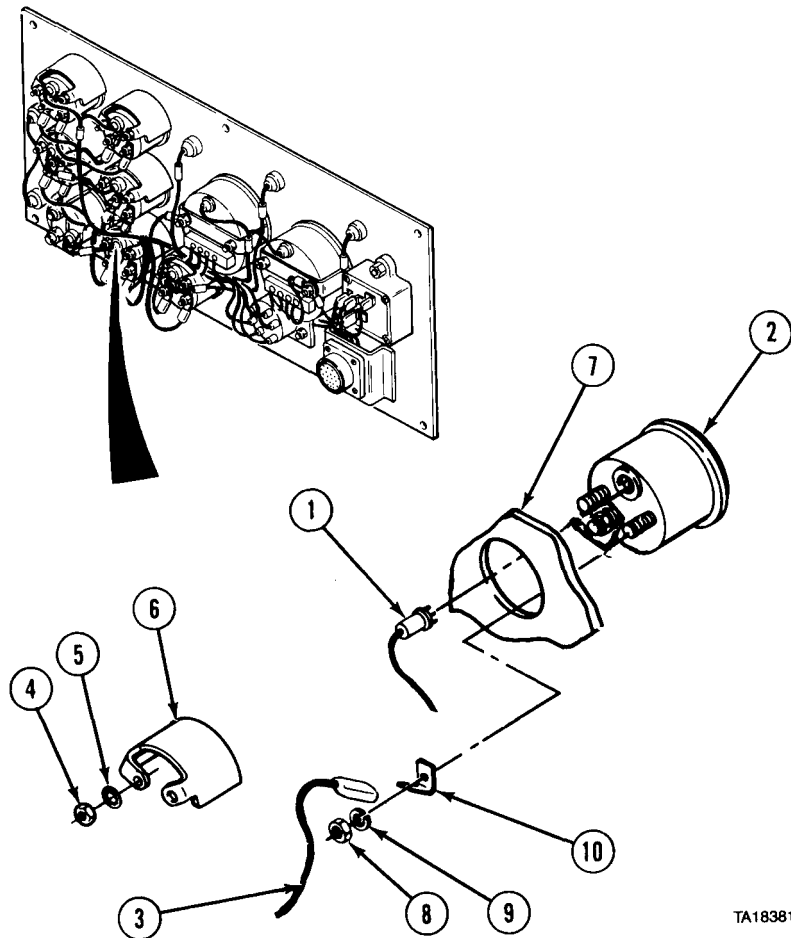
- (2) Disconnect two wires (3) from voltmeter (2).
- (3) Remove two nuts (4), lockwasher (5), and bracket (6).
- (4) Pull voltmeter (2) from instrument panel (7).
- (5) Remove three nuts (8), lockwashers (9), and terminals (10) from voltmeter (2).

b. Installation.

- (1) Install three terminals (10), lockwashers (9), and nuts (8) on voltmeter (2).
- (2) Install voltmeter (2) and bracket (6) on instrument panel (7).
- (3) Install two nuts (4) and lockwashers (5) to secure voltmeter (2) and bracket (6) on instrument panel (6).
- (4) Connect two wires (3) to voltmeter (2).
- (5) Push light socket (1) in voltmeter (2).

c. Follow-on Maintenance.

- (1) Install instrument panel (para 7-19).
- (2) Start engine and check operation of BATTERY gage (TM 9-2320-279-10).
- (3) Shut off engine (TM 9-2320-279-10).



TA183811

END OF TASK

Electrical System Maintenance Instructions (Cont)

| | | |
|---|---|------------------------------|
| 7-25. AMMETER REMOVAL/INSTALLATION. | | |
| This task covers: | | |
| a. Removal | c. Follow-on Maintenance | |
| b. Installation | | |
| INITIAL SETUP | | |
| <i>Models</i> | <i>References</i> | |
| All | None | |
| <i>Test Equipment</i> | <i>Equipment Condition</i> | |
| None | <i>TM or Para</i> | <i>Condition Description</i> |
| <i>Special Tools</i> | Para 7-19 | Instrument panel removed. |
| None | <i>Special Environmental Conditions</i> | |
| <i>Supplies</i> | None | |
| Tags, identification, Item 48, Appendix C | <i>General Safety Instructions</i> | |
| <i>Personnel Required</i> | None | |
| MOS 63S, Heavy wheel vehicle mechanic | | |

Electrical System Maintenance Instructions (Cont)

a. *Removal.*

- (1) Pull light socket (1) from ammeter (2).

NOTE

- Tag and mark wires before disconnecting.
- Some trucks have two wires. Some trucks have three.

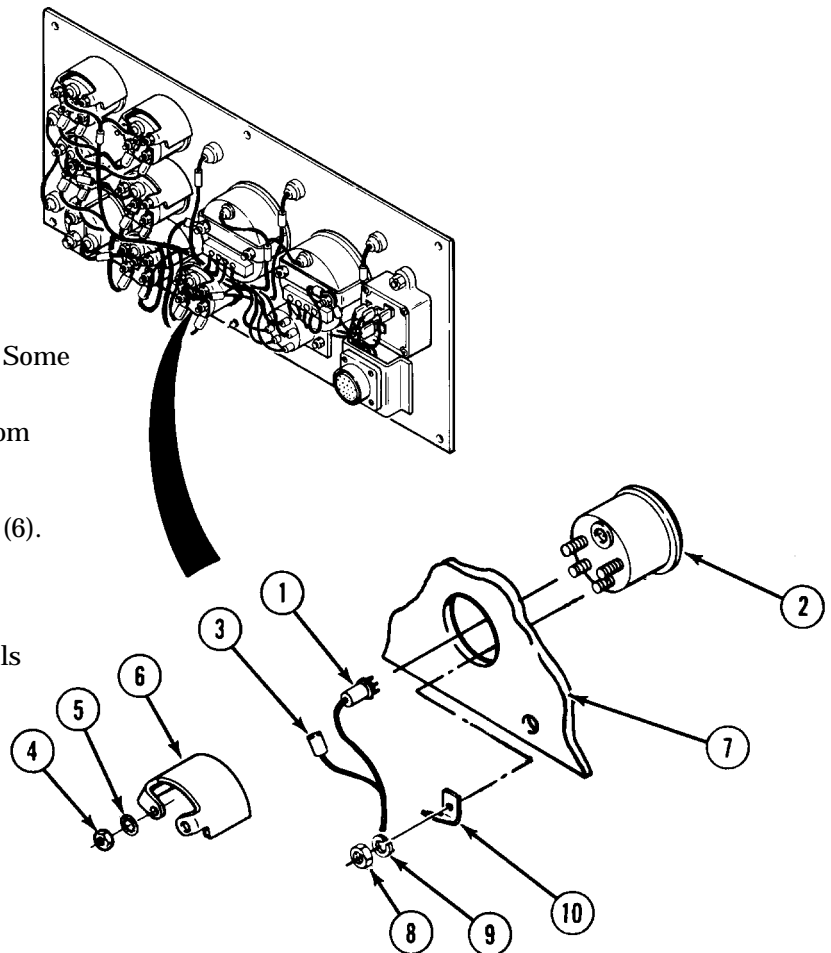
- (2) Disconnect three wires (3) from ammeter (2).
- (3) Remove two nuts (4), lockwashers (5), and bracket (6).
- (4) Pull ammeter (2) from instrument panel (7).
- (5) Remove two nuts (8), lockwashers (9), and terminals (10) from ammeter (2).

b. *Installation.*

- (1) Install two terminals (10), lockwashers (9), and nuts (8) on ammeter (2).
- (2) Install ammeter (2) and bracket (6) on instrument panel (7).
- (3) Install two nuts (4) and lockwashers (5) to secure ammeter (2) and bracket (6) on instrument panel (7).
- (4) Connect three wires (3) to ammeter (2).
- (5) Push light socket (1) in ammeter (2).

c. *Follow-on Maintenance.*

- (1) Install instrument panel (para 7-19).
- (2) Start engine and check operation of AMPERES gage (TM 9-2320-279-10).
- (3) Shut off engine (TM 9-2320-279-10).



END OF TASK

Electrical System Maintenance Instructions (Cont)

| | | |
|--|---|------------------------------|
| 7-26. SPEEDOMETER/ODOMETER REMOVAL/INSTALLATION. | | |
| This task covers: | | |
| a. Removal | c. Follow-on Maintenance | |
| b. Installation | | |
| INITIAL SETUP | | |
| <i>Models</i> | <i>References</i> | |
| All | None | |
| <i>Test Equipment</i> | <i>Equipment Condition</i> | |
| None | <i>TM or Para</i> | <i>Condition Description</i> |
| <i>Special Tools</i> | Para 7-19 | Instrument panel removed. |
| None | <i>Special Environmental Conditions</i> | |
| <i>Supplies</i> | None | |
| Tags, identification, Item 48, Appendix C | <i>General Safety Instructions</i> | |
| <i>Personnel Required</i> | None | |
| MOS 63S, Heavy wheel vehicle mechanic | | |

a. Removal.

- (1) Pull light socket (1) from speedometer/odometer (2).

NOTE

Tag and mark wires before disconnecting.

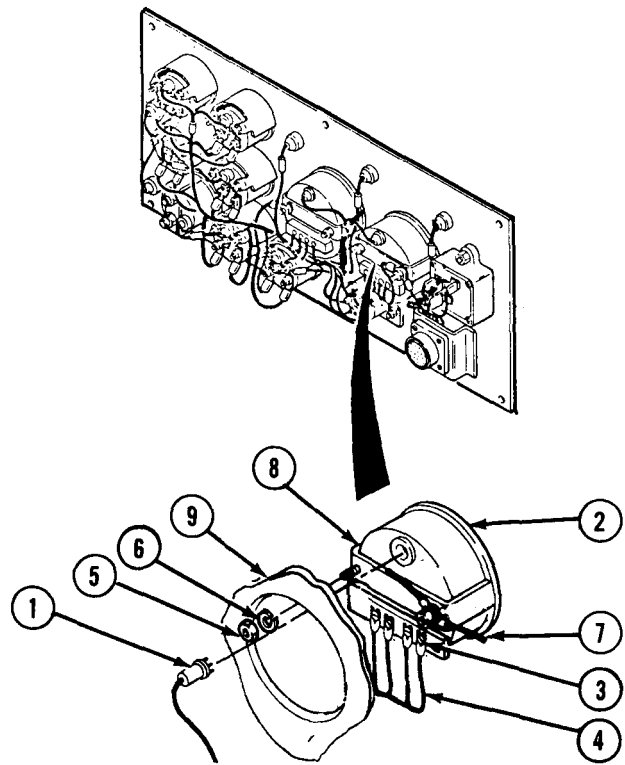
- (2) Loosen four screws (3) and disconnect wires (4) from back of speedometer/odometer (2).
- (3) Remove two nuts (5), lockwashers (6), wires (7), and bracket (8).
- (4) Remove speedometer/odometer (2) from instrument panel (9).

b. Installation.

- (1) Install speedometer/odometer (2) and bracket (8) on instrument panel (9).
- (2) Connect four wires (4) on speedometer/odometer (2). Tighten four screws (3).
- (3) Install two wires (7) with lockwashers (6) and nuts (5).
- (4) Push light socket (1) in speedometer/odometer (2).

c. Follow-on Maintenance.

- (1) Install instrument panel (para 7-19).
- (2) Start engine (TM 9-2320-279-10).
- (3) Operate vehicle and check operation of speedometer/odometer (TM 9-2320-279-10).
- (4) Shut off engine (TM 9-2320-279-10).



TA183807

END OF TASK

Electrical System Maintenance Instructions (Cont)

| | |
|---|--|
| 7-27. TACHOMETER/HOURMETER REMOVAL/INSTALLATION. | |
| This task covers: | |
| a. Removal | c. Follow-on Maintenance |
| b. Installation | |
| INITIAL SETUP | |
| <i>Models</i> | <i>References</i> |
| All | None |
| <i>Test Equipment</i> | <i>Equipment Condition</i> |
| None | <i>TM or Para</i> <i>Condition Description</i> |
| <i>Special Tools</i> | Para 7-19 Instrument panel removed. |
| None | <i>Special Environmental Conditions</i> |
| <i>Supplies</i> | None |
| Tags, identification, Item 48, Appendix C | <i>General Safety Instructions</i> |
| <i>Personnel Required</i> | None |
| MOS 63S, Heavy wheel vehicle mechanic | |

a. Removal.

- (1) Pull light socket (1) from tachometer/hourmeter (2).

NOTE

Tag and mark wires before disconnecting.

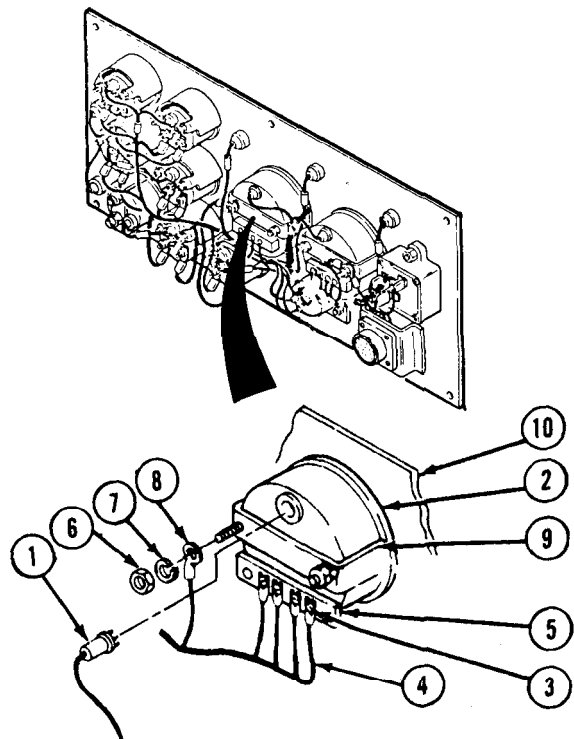
- (2) Loosen four screws (3) and disconnect four wires (4) from terminal strip (5).
- (3) Remove two nuts (6), lockwashers (7), and wire (8).
- (4) Remove bracket (9) and tachometer/hourmeter (2) from instrument panel (10).

b. Installation.

- (1) Install tachometer/hourmeter (2) and bracket (9) on instrument panel (10).
- (2) Install wire (8), two lockwashers (7), and nuts (6) on tachometer/hourmeter (2).
- (3) Connect four wires (4) to terminal strip (5) on tachometer/hourmeter (2). Tighten four screws (3).
- (4) Push light socket (1) in tachometer/hourmeter (2).

c. Follow-on Maintenance.

- (1) Install instrument panel (para 7-19).
- (2) Start engine (TM 9-2320-279-10).
- (3) Check operation of tachometer/hourmeter (TM 9-2320-279-10).
- (4) Shut off engine (TM 9-2320-279-10).



TA183805

END OF TASK

Electrical System Maintenance Instructions (Cont)

| | |
|---|--|
| 7-28. SYSTEM BUZZER REMOVAL/INSTALLATION. | |
| This task covers: | |
| a. Removal | c. Follow-on Maintenance |
| b. Installation | |
| INITIAL SETUP | |
| <i>Models</i> | <i>References</i> |
| All | None |
| <i>Test Equipment</i> | <i>Equipment Condition</i> |
| None | <i>TM or Para</i> <i>Condition Description</i> |
| <i>Special Tools</i> | Para 7-19 Instrument panel removed. |
| None | <i>Special Environmental Conditions</i> |
| <i>Supplies</i> | None |
| Tags, identification, Item 48, Appendix C | <i>General Safety Instructions</i> |
| <i>Personnel Required</i> | None |
| MOS 63S, Heavy wheel vehicle mechanic | |

a. Removal.

NOTE

Tag and mark wires before disconnecting.

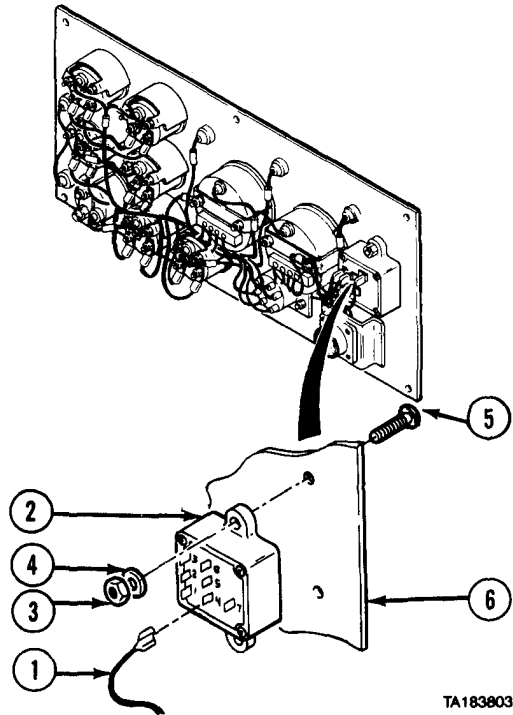
- (1) Disconnect six wires (1) from system buzzer (2).
- (2) Remove two nuts (3), washers (4), screws (5), and system buzzer (2) from instrument panel (6).

b. Installation.

- (1) Install system buzzer (2) with two screws (5), washers (4), and nuts (3) on instrument panel (6).
- (2) Connect six wires (1) to system buzzer (2).

c. Follow-on Maintenance.

- (1) Install instrument panel (para 7-19).
- (2) Start engine (TM 9-2320-279-10).
- (3) Check operation of OIL-WATER and AIR indicator warning system buzzer (TM 9-2320-279-10).
- (4) Shut off engine (TM 9-2320-279-10).



TA183803

END OF TASK

Electrical System Maintenance Instructions (Cont)

| | |
|--|---|
| 7-29. JUNCTION BLOCK REMOVAL/INSTALLATION. | |
| This task covers: | |
| a. Removal b. Installation | c. Follow-on Maintenance |
| INITIAL SETUP | |
| <i>Models</i> All | <i>References</i> None |
| <i>Test Equipment</i> None | <i>Equipment Condition</i> TM or Para Para 7-19 |
| <i>Special Tools</i> None | <i>Condition Description</i> Instrument panel removed. |
| <i>Supplies</i> Tags, identification, Item 48, Appendix C | <i>Special Environmental Conditions</i> None |
| <i>Personnel Required</i> MOS 63S, Heavy wheel vehicle mechanic | <i>General Safety Instructions</i> None |

a. Removal.

NOTE

Tag and mark wires before disconnecting.

- (1) Disconnect six wires (1) from junction block (2).
- (2) Remove two locknuts (3), washers (4), screws (5), and junction block (2) from instrument panel (6).

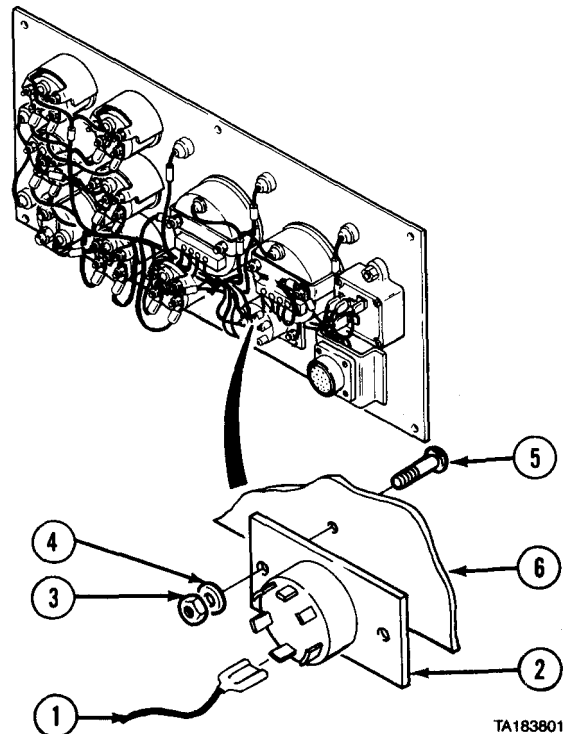
b. Installation.

- (1) Attach junction block (2) to instrument panel (6) with two screws (5), washers (4), and locknuts (3).
- (2) Connect six wires (1) to junction block (2).

c. Follow-on Maintenance.

- (1) Install instrument panel (para 7-19).
- (2) Start engine (TM 9-2320-279-10).
- (3) Check operation of instrument panel switches (TM 9-2320-279-10).
- (4) Shut off engine (TM 9-2320-279-10).

END OF TASK



TA183801

Electrical System Maintenance Instructions (Cont)

| | | |
|---|---|------------------------------|
| 7-30. TURN INDICATOR LIGHT ASSEMBLY REMOVAL/INSTALLATION. | | |
| This task covers: | | |
| a. Removal | c. Follow-on Maintenance | |
| b. Installation | | |
| INITIAL SETUP | | |
| <i>Models</i> | <i>References</i> | |
| All | None | |
| <i>Test Equipment</i> | <i>Equipment Condition</i> | |
| None | <i>TM or Para</i> | <i>Condition Description</i> |
| <i>Special Tools</i> | Para 7-19 | Instrument panel removed. |
| None | <i>Special Environmental Conditions</i> | |
| <i>Supplies</i> | None | |
| Connector, electrical, butt, Item 19, Appendix C | <i>General Safety Instructions</i> | |
| <i>Personnel Required</i> | None | |
| MOS 63S, Heavy wheel vehicle mechanic | | |

Electrical System Maintenance Instructions (Cont)

*a. Removal.***NOTE**

Both turn indicator lights are removed and installed the same way.

- (1) Pull turn indicator light socket (1) out of receptacle (2).
- (2) Remove bulb (3) from turn indicator light socket (1).
- (3) Remove shield (4). Remove lens (5) from shield. Remove force ring (6) from lens.
- (4) Remove nut (7), lockwashers (8), and receptacle (2) from instrument panel (9).

NOTE

Some trucks do not have butt connectors.

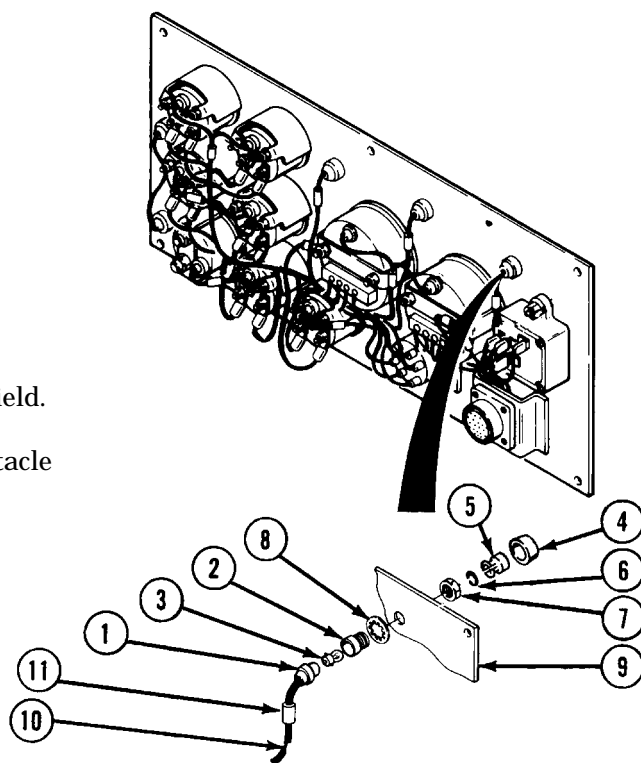
- (5) Cut wire (10) at rear of electrical butt connector (11) to remove turn indicator light socket (1).

b. Installation.

- (1) Install lockwasher (8) on receptacle (2) and insert receptacle through instrument panel (9).
- (2) Install nut (7).
- (3) Install force ring (6) in lens (5). Install lens in shield (4). Install shield.
- (4) Install bulb (3) into turn indicator light socket (1).
- (5) Install electrical butt connector (11) on wires (10).
- (6) Install turn indicator light socket (1) into receptacle (2).

c. Follow-on Maintenance.

- (1) Install instrument panel (para 7-19).
- (2) Check operation of turn indicator light (TM 9-2320-279-10).



END OF TASK

Electrical System Maintenance Instructions (Cont)

| | | |
|--|---|------------------------------|
| 7-31. WARNING INDICATOR LIGHT ASSEMBLY REMOVAL/INSTALLATION. | | |
| This task covers: | | |
| a. Removal | c. Follow-on Maintenance | |
| b. Installation | | |
| INITIAL SETUP | | |
| <i>Models</i> | <i>References</i> | |
| All | None | |
| <i>Test Equipment</i> | <i>Equipment Condition</i> | |
| None | <i>TM or Para</i> | <i>Condition Description</i> |
| <i>Special Tools</i> | Para 7-19 | Instrument panel removed. |
| None | <i>Special Environmental Conditions</i> | |
| <i>Supplies</i> | None | |
| Connector, electrical, butt, Item 19, Appendix C | <i>General Safety Instructions</i> | |
| Tags, identification, Item 48, Appendix C | None | |
| <i>Personnel Required</i> | | |
| MOS 63S, Heavy wheel vehicle mechanic | | |

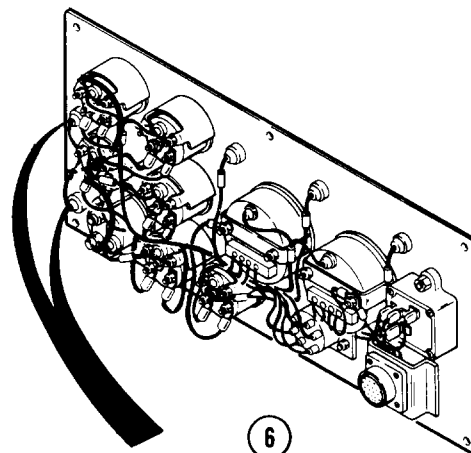
Electrical System Maintenance Instructions (Cont)

a. *Removal.*

NOTE

Both warning indicator lights are removed and installed the same way.

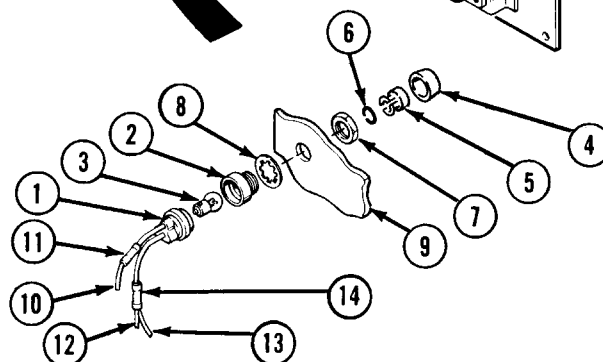
- (1) Pull warning indicator light socket (1) out of receptacle (2).
- (2) Remove light bulb (3) from warning indicator light socket (1).
- (3) Remove shield (4). Remove lens (5) from shield. Remove force ring (6) from lens.
- (4) Remove nut (7), lockwasher (8), and receptacle (2) from instrument panel (9).



NOTE

Some trucks do not have butt connectors.

- (5) Cut wire (10) at rear of electrical butt connector (11).



NOTE

Tag and mark wires before removing.

- (6) Cut wires (12 and 13) at rear of electrical butt connector (14) and remove warning indicator light socket (1).

b. *Installation.*

- (1) Install lockwasher (8) on receptacle (2) and insert receptacle through instrument panel (9).
- (2) Install nut (7).
- (3) Install force ring (6) in lens (5). Install lens in shield (4). Install shield.
- (4) Install light bulb (3) in warning indicator light socket (1).
- (5) Install electrical butt connector (11) on wires (10).
- (6) Install electrical butt connector (14) on two wires (12 and 13).
- (7) Install warning indicator light socket (1) in receptacle (2).

c. *Follow-on Maintenance.*

- (1) Install instrument panel (para 7-19).
- (2) Check operation of turn indicator light (TM 9-2320-279-10).

END OF TASK

Electrical System Maintenance Instructions (Cont)

| 7-32. HIGH BEAM INDICATOR LIGHT ASSEMBLY REMOVAL/INSTALLATION. | |
|--|---|
| This task covers: | |
| a. Removal | c. Follow-on Maintenance |
| b. Installation | |
| INITIAL SETUP | |
| <i>Models</i> | <i>References</i> |
| All | None |
| <i>Test Equipment</i> | <i>Equipment Condition</i> |
| None | TM or Para Para 7-19 |
| <i>Special Tools</i> | <i>Condition Description</i> |
| None | Instrument panel removed. |
| <i>Supplies</i> | <i>Special Environmental Conditions</i> |
| Connector, electrical, butt, Item 19, Appendix C | None |
| <i>Personnel Required</i> | <i>General Safety Instructions</i> |
| MOS 63S, Heavy wheel vehicle mechanic | None |

a. Removal.

- (1) Pull high beam indicator light socket (1) out of receptacle (2).
- (2) Remove shield (3), receptacle (2), and lockwasher (4) from instrument panel (5).

NOTE

Some trucks do not have butt connectors.

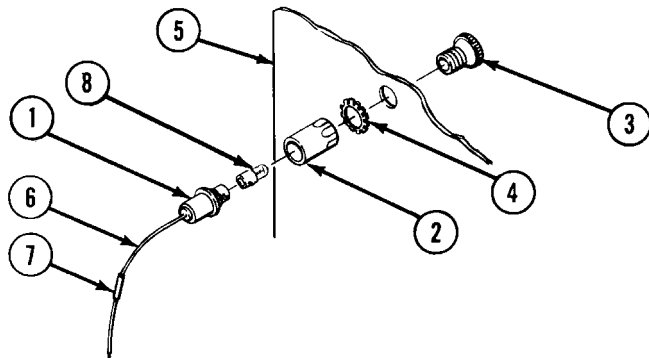
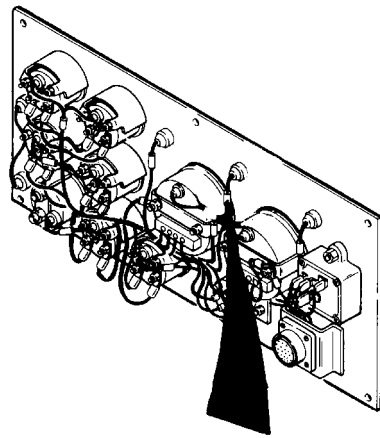
- (3) Cut wire (6) at electrical butt connector (7), and remove high beam indicator light socket (1).
- (4) Remove bulb (8) from high beam indicator light socket (1).

b. Installation.

- (1) Install shield (3) with lockwasher (4) and receptacle (2) on instrument panel (5).
- (2) Insert wires (6) in electrical butt connector (7).
- (3) Install bulb (8) in high beam indicator light socket (1) and push high beam indicator light socket into receptacle (2).

c. Follow-on Maintenance.

- (1) Install instrument panel (para 7-19).
- (2) Check operation of turn indicator light (TM 9-2320-279-10).

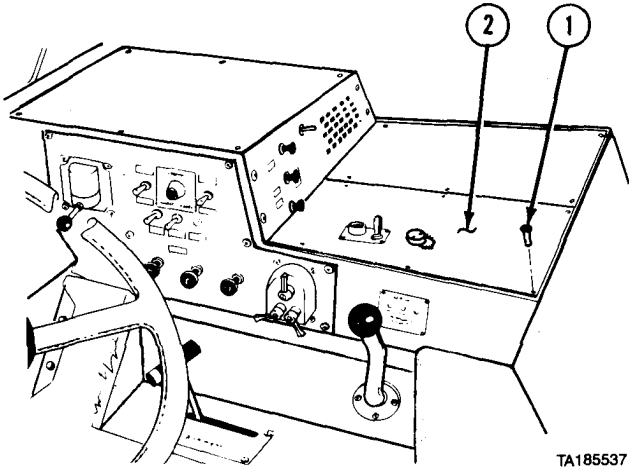


END OF TASK

Electrical System Maintenance Instructions (Cont)

| | | |
|---|---|------------------------------|
| 7-33. IGNITION RELAY REMOVAL/INSTALLATION. | | |
| This task covers: | | |
| a. Removal | c. Follow-on Maintenance | |
| b. Installation | | |
| INITIAL SETUP | | |
| <i>Models</i> | <i>References</i> | |
| All | None | |
| <i>Test Equipment</i> | <i>Equipment Condition</i> | |
| None | <i>TM or Para</i> | <i>Condition Description</i> |
| <i>Special Tools</i> | Para 7-91 | Batteries disconnected. |
| None | <i>Special Environmental Conditions</i> | |
| <i>Supplies</i> | None | |
| Tags, identification, Item 48, Appendix C | <i>General Safety Instructions</i> | |
| <i>Personnel Required</i> | None | |
| MOS 63S, Heavy wheel vehicle mechanic | | |

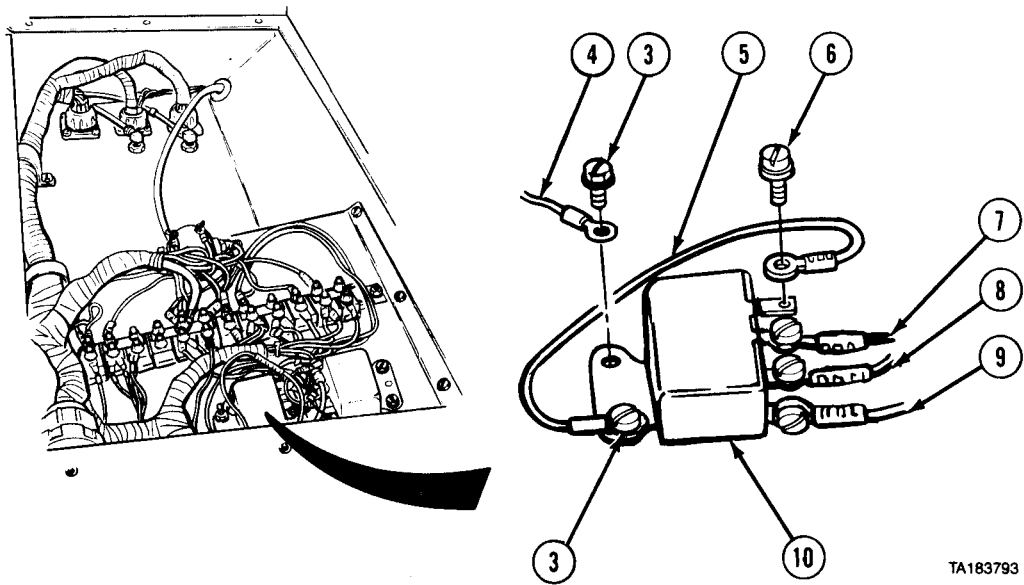
a. Removal.



(1) Remove six screws (1) and heater compartment cover (2).

Electrical System Maintenance Instructions (Cont).

7-33. IGNITION RELAY REMOVAL/INSTALLATION (CONT).



TA183793

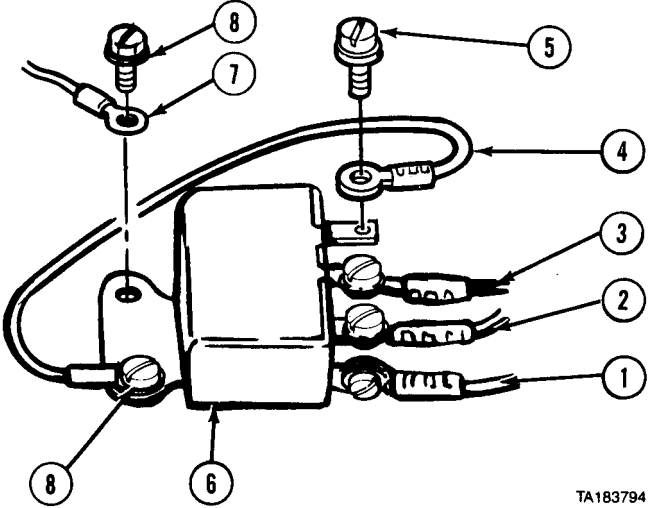
NOTE

Tag and mark wires before disconnecting.

- (2) Remove two screws (3), ground wire (4), and ground wire (5).
- (3) Remove four screws (6). Disconnect three wires (7, 8, and 9) and ground wire (5).
- (4) Remove ignition relay (10).

b. Installation.

- (1) Connect three wires (1, 2, and 3) and wire (4) with four screws (5). Tighten screws.
- (2) Install ignition relay (6), ground wire (7), and ground wire (4) with two screws (8).



TA183794

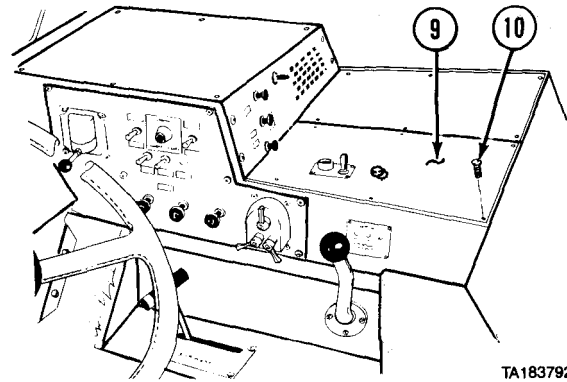
Electrical System Maintenance Instructions (Cont)

(3) Install heater compartment cover (9) with six screws (10).

c. Follow-on Maintenance.

- (1) Connect batteries (para 7-91).
- (2) Check operation of relay (TM 9-2320-279-10).

END OF TASK

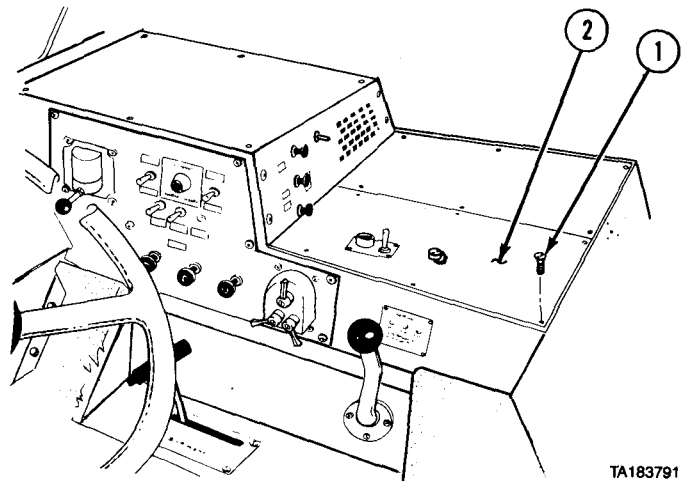


TA183792

| | | |
|---|---|------------------------------|
| 7-34. HORN RELAY REMOVAL/INSTALLATION. | | |
| This task covers: | | |
| a. Removal | c. Follow-on Maintenance | |
| b. Installation | | |
| INITIAL SETUP | | |
| <i>Models</i> | <i>References</i> | |
| All | None | |
| <i>Test Equipment</i> | <i>Equipment Condition</i> | |
| None | <i>TM or Para</i> | <i>Condition Description</i> |
| <i>Special Tools</i> | Para 7-91 | Batteries disconnected. |
| None | <i>Special Environmental Conditions</i> | |
| <i>Supplies</i> | None | |
| Tags, identification, Item 48, Appendix C | <i>General Safety Instructions</i> | |
| <i>Personnel Required</i> | None | |
| MOS 63S, Heavy wheel vehicle mechanic | | |

a. Removal.

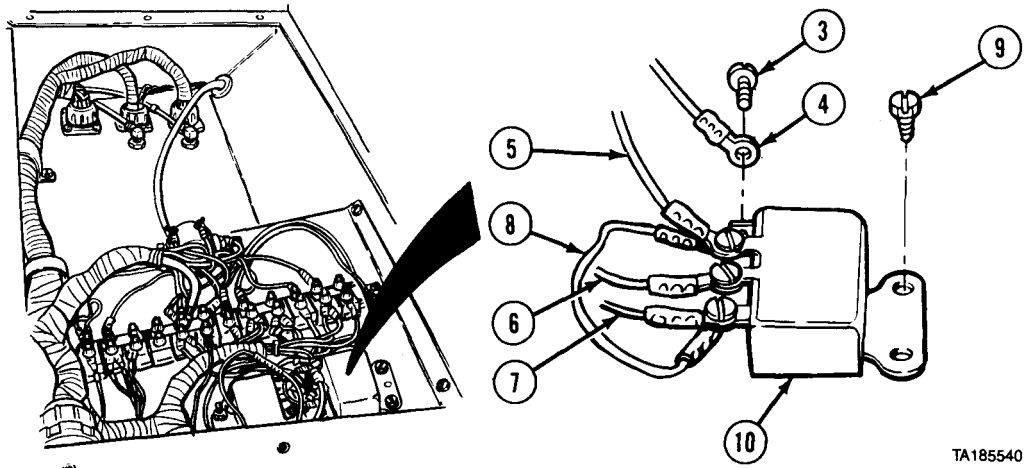
(1) Remove six screws (1) and heater compartment cover (2).



TA183791

Electrical System Maintenance Instructions (Cont)

7-34. HORN RELAY REMOVAL/INSTALLATION (CONT).



TA185540

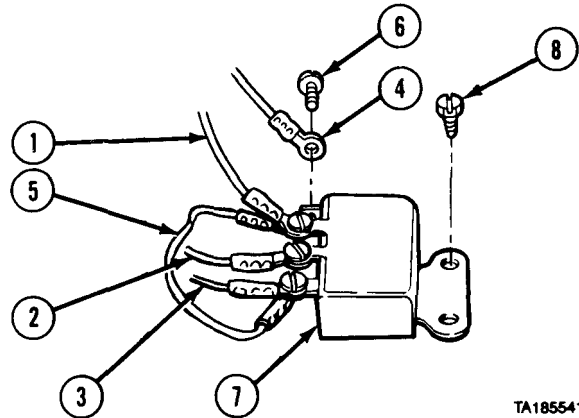
NOTE

Tag and mark wires before disconnecting.

- (2) Remove four screws (3). Disconnect four wires (4, 5, 6, and 7) and ground wire (8).
- (3) Remove two screws (9) and relay (10).

b. Installation.

- (1) Connect four wires (1, 2, 3, and 4) and ground wire (5) with four screws (6). Tighten screws.
- (2) Install relay (7) with two screws (8).



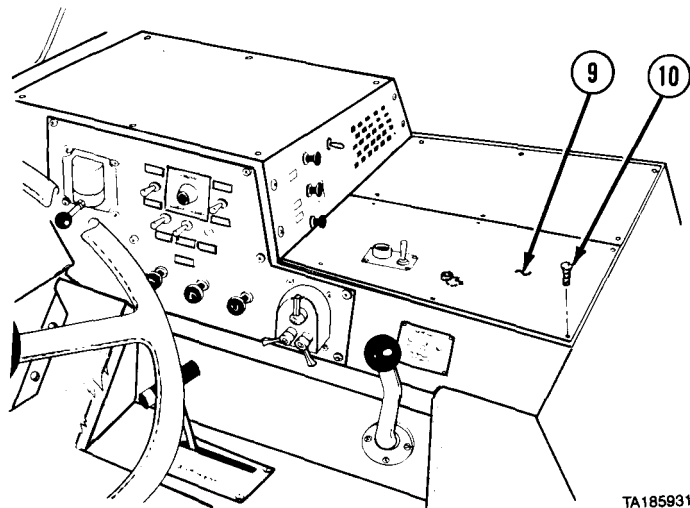
TA185541

- (3) Install heater compartment cover (9) with six screws (10).

c. Follow-on Maintenance.

- (1) Connect batteries (para 7-91).
- (2) Check operation of horn relay (TM 9-2320-279-10).

END OF TASK

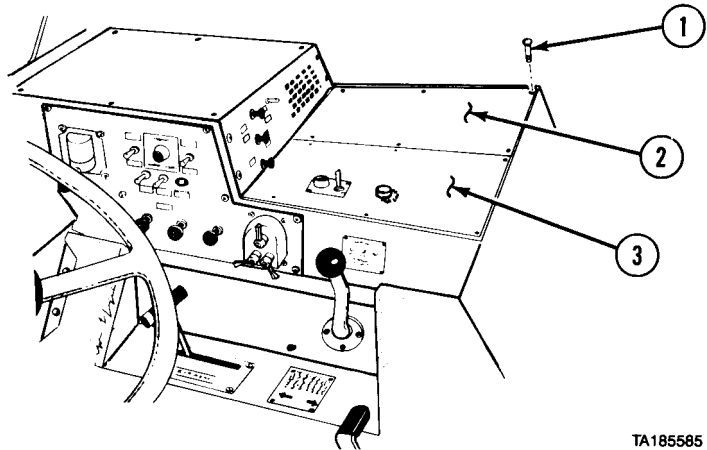


TA185931

Electrical System Maintenance Instructions (Cont)

| | |
|---|--|
| 7-35. MAGNETIC SWITCH REMOVAL/INSTALLATION. | |
| This task covers: | |
| a. Removal | c. Follow-on Maintenance |
| b. Installation | |
| INITIAL SETUP | |
| <i>Models</i> | <i>References</i> |
| All | None |
| <i>Test Equipment</i> | <i>Equipment Condition</i> |
| None | <i>TM or Para</i> <i>Condition Description</i> |
| <i>Special Tools</i> | Para 7-91 Batteries disconnected. |
| None | <i>Special Environmental Conditions</i> |
| <i>Supplies</i> | None |
| Tags, identification, Item 48, Appendix C | <i>General Safety Instructions</i> |
| <i>Personnel Required</i> | None |
| MOS 63S, Heavy wheel vehicle mechanic | |

- a. Removal.
 (1) Remove 11 screws (1) and heater compartment covers (2 and 3).



TA185585

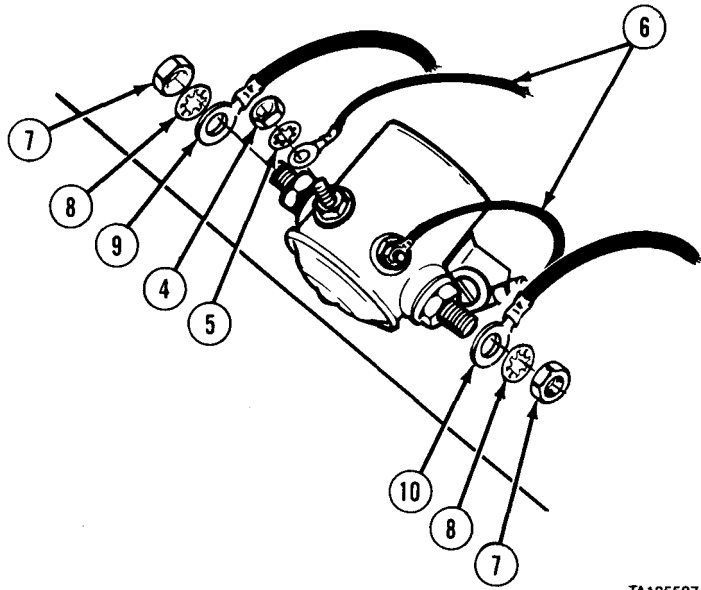
Electrical System Maintenance Instructions (Cont)

7-35. MAGNETIC SWITCH REMOVAL/INSTALLATION (CONT).

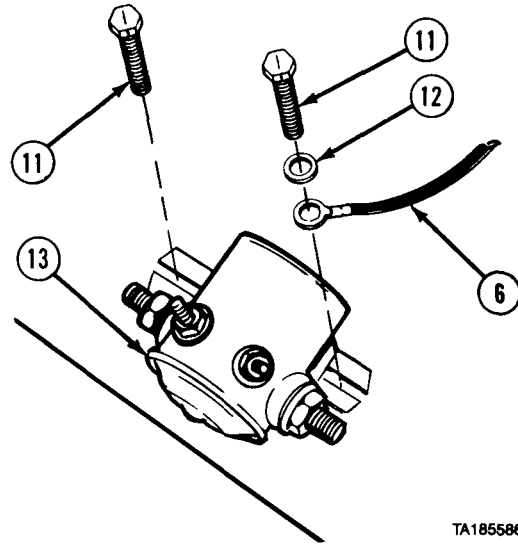
NOTE

Tag and mark wires before disconnecting or removing.

- (2) Remove two nuts (4), lockwashers (5), and disconnect two wires (6).
- (3) Remove two nuts (7), lockwashers (8), and disconnect two wires (9 and 10).



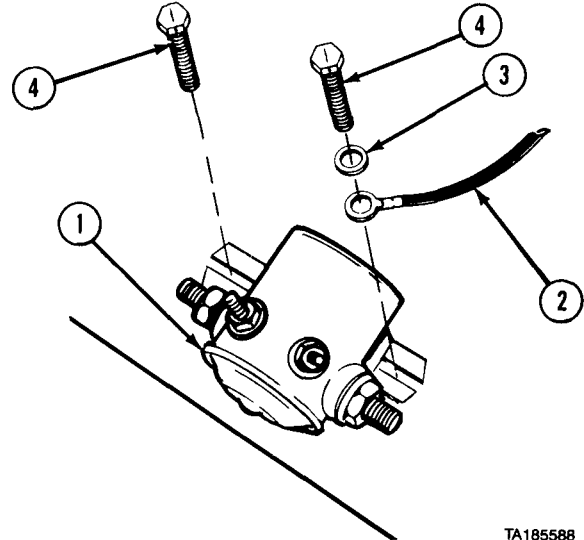
- (4) Remove two screws (11), washer (12), wire (6), and magnetic switch (13).



Electrical System Maintenance Instructions (Cont)

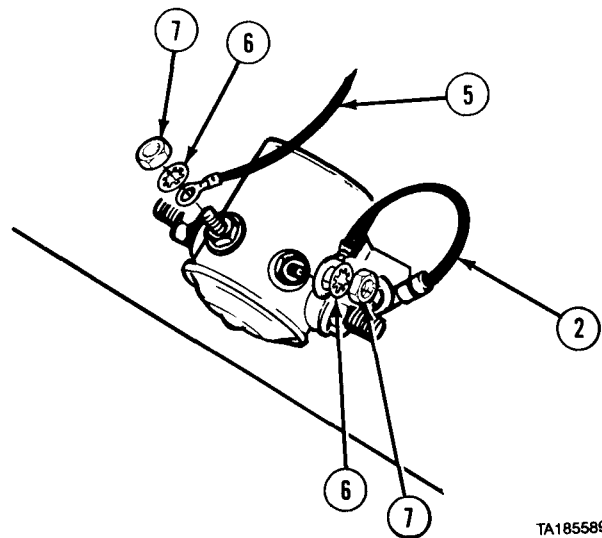
b. *Installation.*

(1) Install magnetic switch (1) and wire (2) with washer (3) and two screws (4).



TA185588

(2) Install two wires (2 and 5) with two lockwashers (6) and nuts (7). Tighten nuts to 20 to 25 in-lb (2.25 to 2.8 N·m).

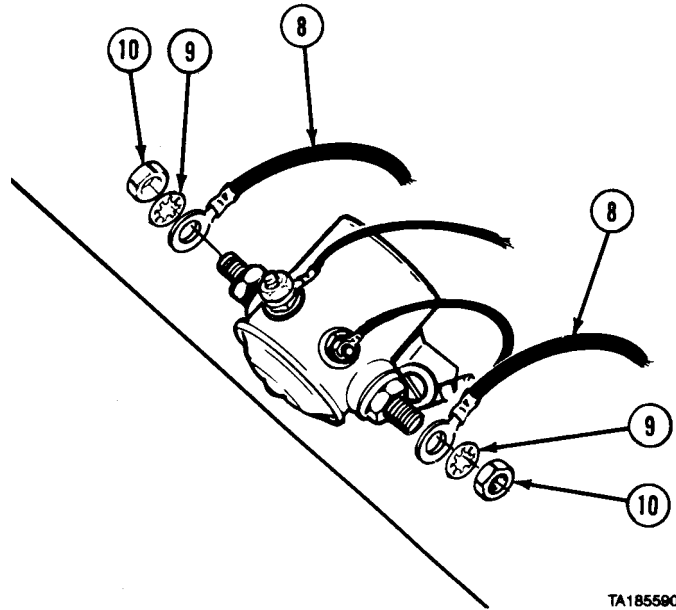


TA185589

Electrical System Maintenance Instructions (Cont)

7-35. MAGNETIC SWITCH REMOVAL/INSTALLATION (CONT).

- (3) Connect two wires (8) with lockwashers (9) and nuts (10). Tighten nuts to 30 to 35 in-lb (3.4 to 4.0 N·m).



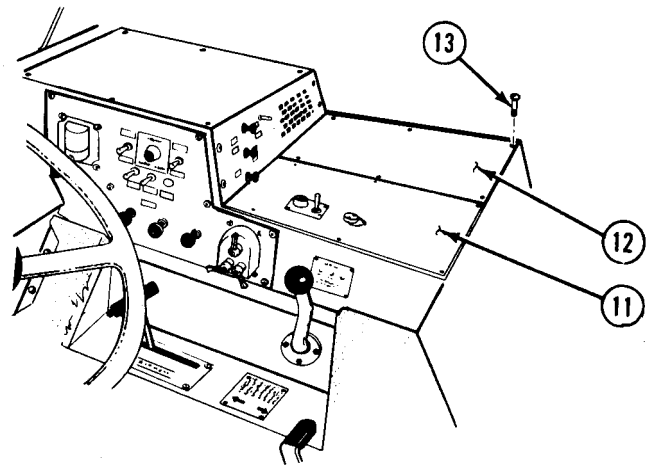
TA185590

- (4) Install heater compartment covers (11 and 12) with 11 screws (13).

c. Follow-on Maintenance.

- (1) Connect batteries (para 7-91).
- (2) Check operation of main light switch (TM 9-2320-279-10).

END OF TASK

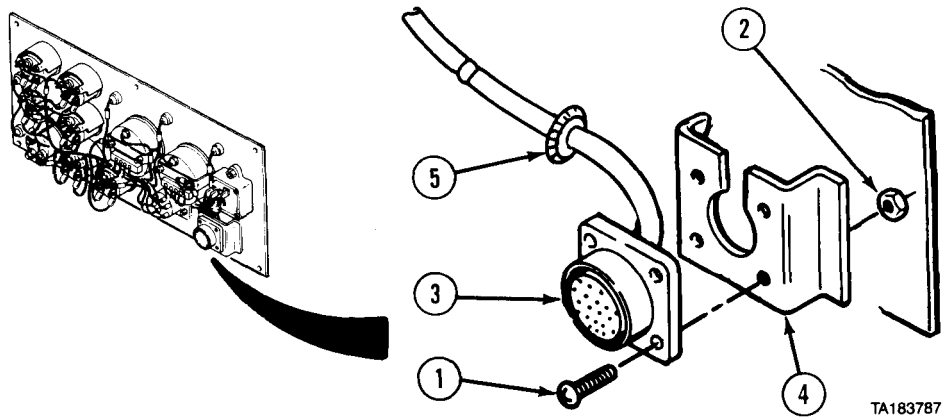


TA185591

Electrical System Maintenance Instructions (Cont)

| | | |
|---|---|------------------------------|
| 7-36. INSTRUMENT PANEL RECEPTACLE REMOVAL/INSTALLATION. | | |
| This task covers: | | |
| a. Removal | c. Follow-on Maintenance | |
| b. Installation | | |
| INITIAL SETUP | | |
| <i>Models</i> | <i>References</i> | |
| All | None | |
| <i>Test Equipment</i> | <i>Equipment Condition</i> | |
| None | <i>TM or Para</i> | <i>Condition Description</i> |
| <i>Special Tools</i> | Para 7-19 | Instrument panel removed. |
| None | <i>Special Environmental Conditions</i> | |
| <i>Supplies</i> | None | |
| Tags, identification, Item 48, Appendix C | <i>General Safety Instructions</i> | |
| <i>Personnel Required</i> | None | |
| MOS 63S, Heavy wheel vehicle mechanic | | |

a. Removal.



- (1) Remove four screws (1), locknuts (2), and receptacle (3) from instrument panel bracket (4).
- (2) Unscrew back shell (5) from receptacle (3).

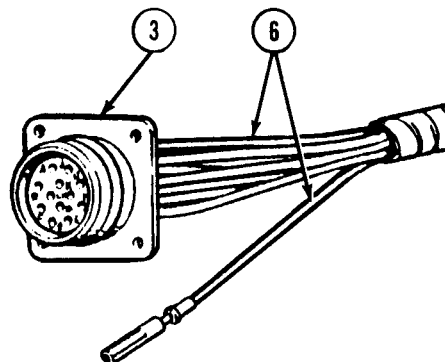
Electrical System Maintenance Instructions (Cont)

7-36. INSTRUMENT PANEL RECEPTACLE REMOVAL/INSTALLATION (CONT).

NOTE

Tag and mark wires before removing.

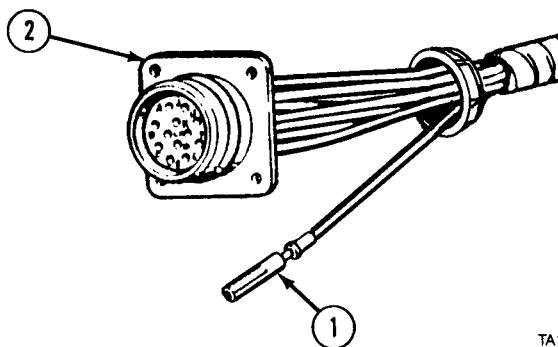
(3) Remove harness wires (6) from receptacle (3).



TA183788

b. Installation.

(1) Insert pins (1) in receptacle (2).



TA183789

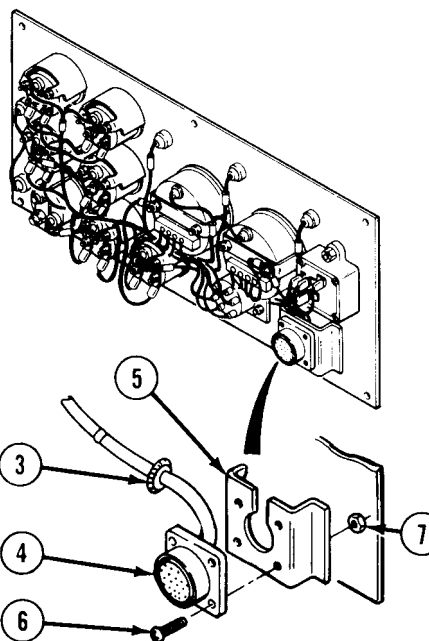
(2) Install back shell (3) on receptacle (4).

(3) Install receptacle (4) on instrument panel bracket (5) with four screws (6) and locknuts (7).

c. Follow-on Maintenance.

(1) Install instrument panel (para 7-19).

(2) Test operation of instrument panel indicators and gages (TM 9-2320-279-10).



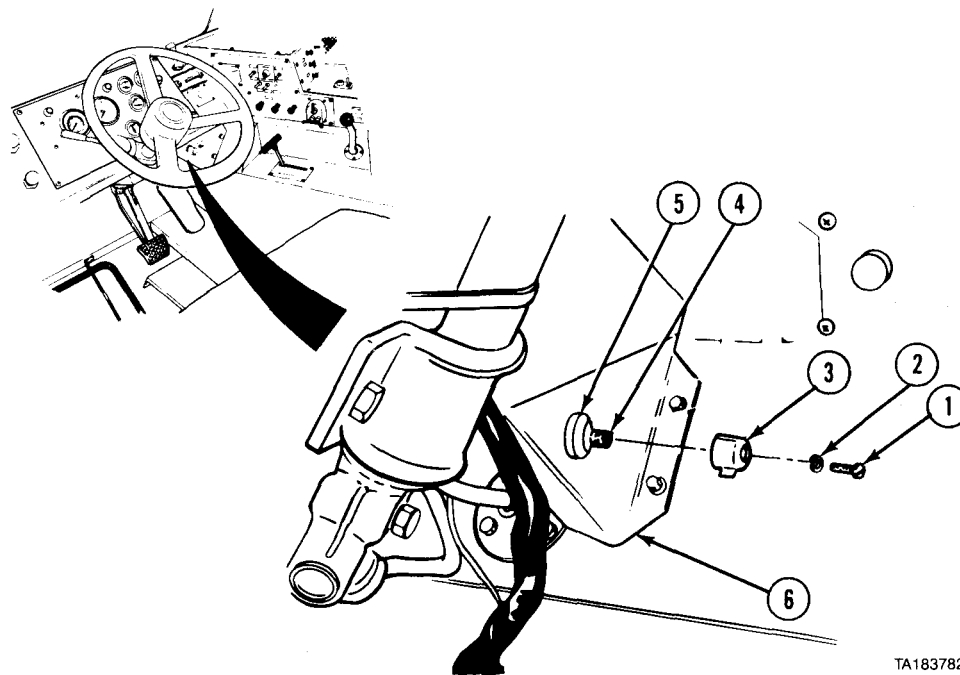
TA185600

END OF TASK

Electrical System Maintenance Instructions (Cont)

| | | |
|---|---|------------------------------|
| 7-37. ENGINE START SWITCH REMOVAL/INSTALLATION. | | |
| This task covers: | | |
| a. Removal | c. Follow-on Maintenance | |
| b. Installation | | |
| INITIAL SETUP | | |
| <i>Models</i> | <i>References</i> | |
| All | None | |
| <i>Test Equipment</i> | <i>Equipment Condition</i> | |
| None | <i>TM or Para</i> | <i>Condition Description</i> |
| <i>Special Tools</i> | Para 7-91 | Batteries disconnected. |
| None | <i>Special Environmental Conditions</i> | |
| <i>Supplies</i> | None | |
| Tags, identification, Item 48, Appendix C | <i>General Safety Instructions</i> | |
| <i>Personnel Required</i> | None | |
| MOS 63S, Heavy wheel vehicle mechanic | | |

a. Removal.



TA183782

- (1) Remove screw (1), lockwasher (2), and engine start switch knob (3) from engine start switch (4).
- (2) Remove knurled nut (5) from engine start switch (4).
- (3) Remove engine start switch (4) from back of mounting bracket (6).

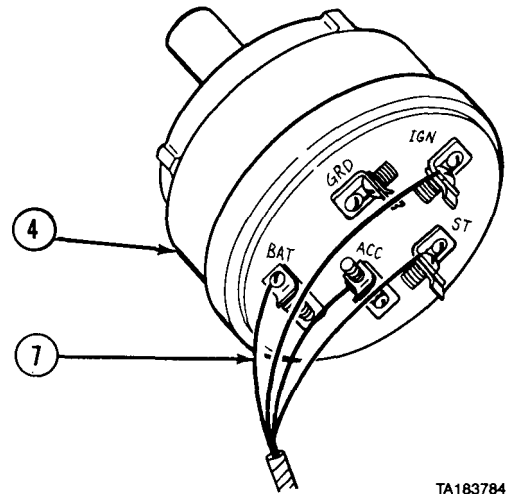
Electrical System Maintenance Instructions (Cont)

7-37. ENGINE START SWITCH REMOVAL/INSTALLATION (CONT).

NOTE

Tag and mark wires before disconnecting.

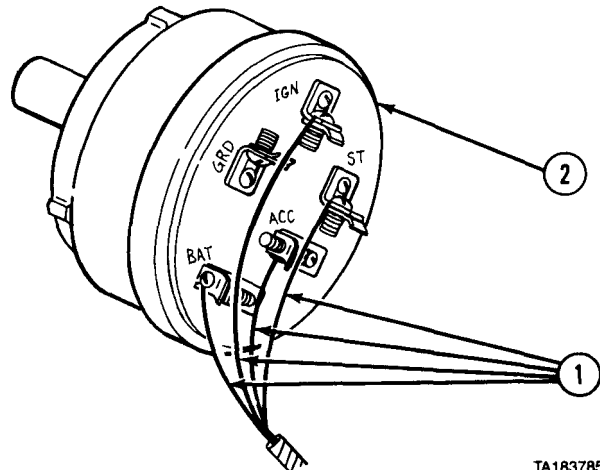
(4) Disconnect four wires (7) from engine start switch (4).



TA183784

b. Installation.

(1) Connect four wires (1) to engine start switch (2).

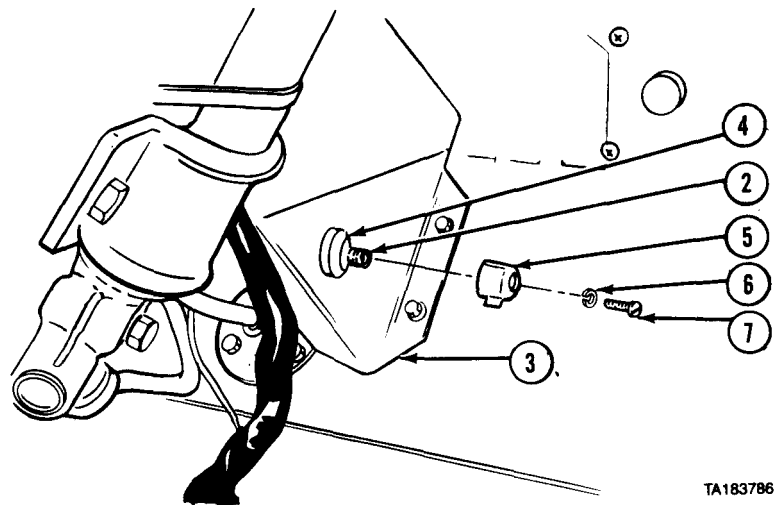


TA183785

- (2) Position engine start switch (2) into mounting hole from behind mounting bracket (3).
- (3) Install and tighten knurled nut (4) on engine start switch (2).
- (4) Install engine start switch knob (5) with lockwasher (6) and screw (7).

c. Follow-on Maintenance.

- (1) Connect batteries (para 7-91).
- (2) Check operation of engine start switch (TM 9-2320-279-10).



TA183786

END OF TASK

Electrical System Maintenance Instructions (Cont)

| | | |
|---|---|------------------------------|
| 7-38. ENGINE STOP SWITCH REMOVAL/INSTALLATION. | | |
| This task covers: | | |
| a. Removal | c. Follow-on Maintenance | |
| b. Installation | | |
| INITIAL SETUP | | |
| <i>Models</i> | <i>References</i> | |
| All | None | |
| <i>Test Equipment</i> | <i>Equipment Condition</i> | |
| None | <i>TM or Para</i> | <i>Condition Description</i> |
| <i>Special Tools</i> | Para 7-91 | Batteries disconnected. |
| None | <i>Special Environmental Conditions</i> | |
| <i>Supplies</i> | None | |
| Tags, identification, Item 48, Appendix C | <i>General Safety Instructions</i> | |
| <i>Personnel Required</i> | None | |
| MOS 63S, Heavy wheel vehicle mechanic | | |

a. Removal.

- (1) Remove nut (1) from ENGINE STOP switch (2).
- (2) Remove ENGINE STOP switch (2) from bracket (3).

NOTE

Tag and mark wires before disconnecting.

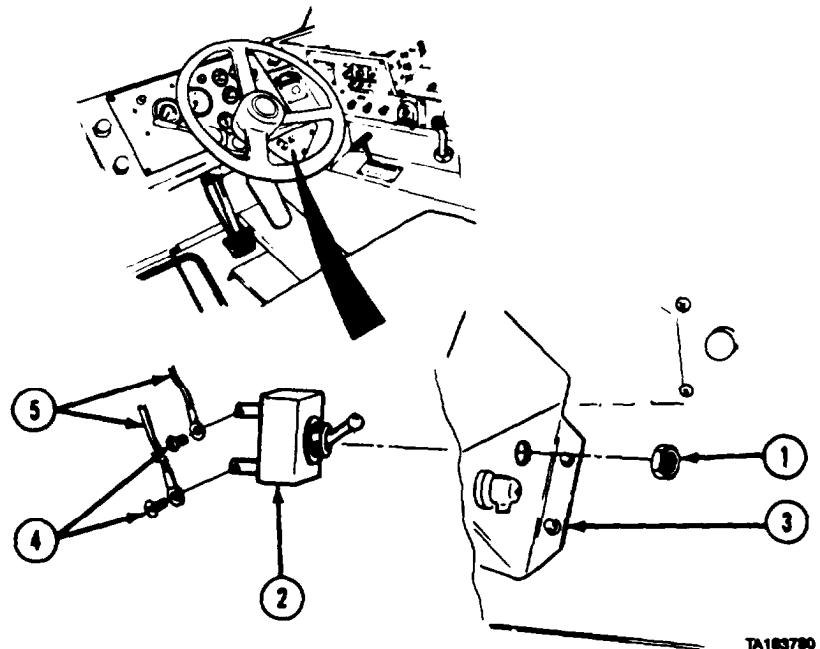
- (3) Remove two screws (4) and disconnect wires (5).

b. Installation.

- (1) Connect two wires (5) to ENGINE STOP switch (2) with two screws (4).
- (2) Install ENGINE STOP switch (2) in bracket (3).
- (3) Install nut (1) on ENGINE STOP switch (2).

c. follow-on Maintenance.

- (1) Connect batteries (para 7-91).
- (2) Start engine, check operation of ENGINE STOP switch (TM 9-2320-279-10).



TA183780

END OF TASK

Electrical System Maintenance Instructions (Cont)

7-39. SIDE PANEL SWITCHES REMOVAL/INSTALLATION.

This task covers:

- a. Removal
- b. Installation
- c. Follow-on Maintenance

INITIAL SETUP

Models

All (M983, M984, M1977-CBT only work light switch)

References

None

Test Equipment

None

Equipment Condition

| <i>TM or Para</i> | <i>Condition</i> | <i>Description</i> |
|-------------------|-------------------------|--------------------|
| Para 7-91 | Batteries disconnected. | |

Special Tools

None

Special Environmental Conditions

None

Supplies

Tags, identification, Item 48, Appendix C

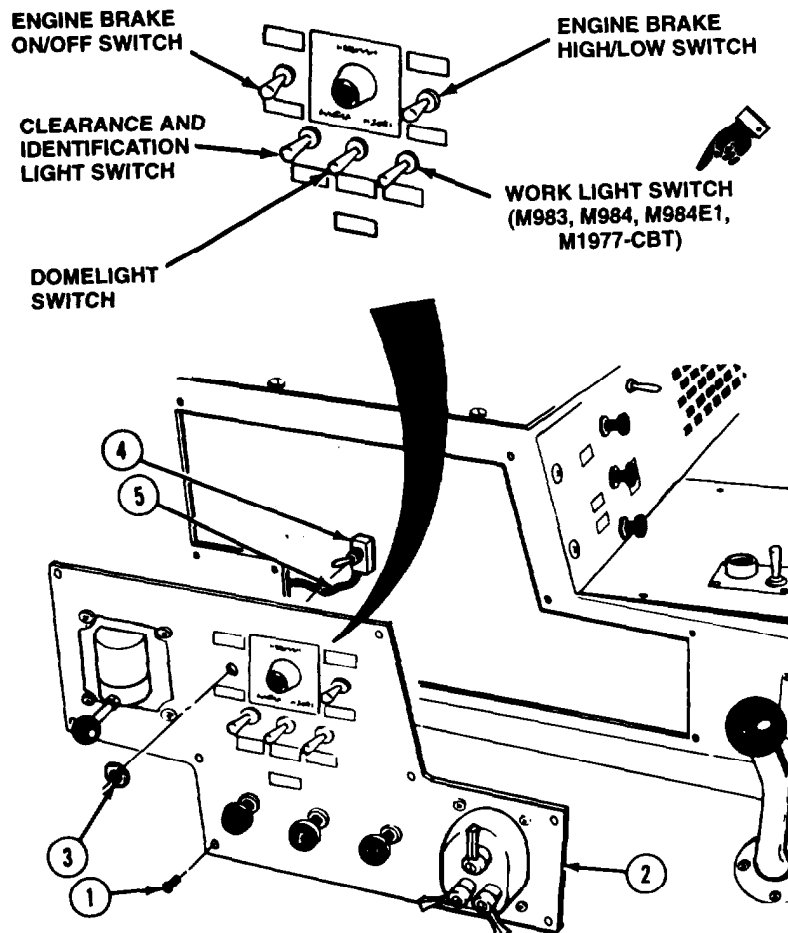
General Safety Instructions

None

Personnel Required

MOS 63S, Heavy wheel vehicle mechanic

Electrical System Maintenance Instructions (Cont)

a. Removal**NOTE**

- The following switches are removed and installed the same way; ENGINE BRAKE ON/OFF switch, ENGINE BRAKE HIGH/LOW switch, clearance and identification light switch, domelight switch, and WORK LIGHT switch.
- ENGINE BRAKE ON/OFF switch is shown.

- (1) Remove eight screws (1) and side panel (2).
- (2) Remove nut (3) and switch (4) from side panel (2).

NOTE

Tag and mark wires before disconnecting.

- (3) Disconnect wires (5).

b. Installation.

- (1) Connect wires (5) to switch (4).
- (2) Install switch (4) and nut (3) on side panel (2). Tighten nut.
- (3) position side panel (2) and make sure all wires (5) are behind side panel. Install and tighten eight screws (1).

c. Follow-on Maintenance.

- (1) Connect batteries (para 7-91).
- (2) Check switch operation (TM 9-2320-279-10).

END OF TASK

Electrical System Maintenance Instructions (Cont)

7-40. ENGINE BRAKE INDICATOR LIGHT REMOVAL/INSTALLATION.

This task covers:

- a. Removal
- b. Installation
- c. Follow-on Maintenance

INITIAL SETUP

Models
All

References
None

Test Equipment
None

Equipment Condition

Special Tools
None

TM or Para Condition Description
Para 7-91 Batteries disconnected.

Supplies
Tags, identification, Item 48, Appendix C

Special Environmental Conditions
None

Personnel Required
MOS 63S, Heavy wheel vehicle mechanic

General Safety Instructions
None

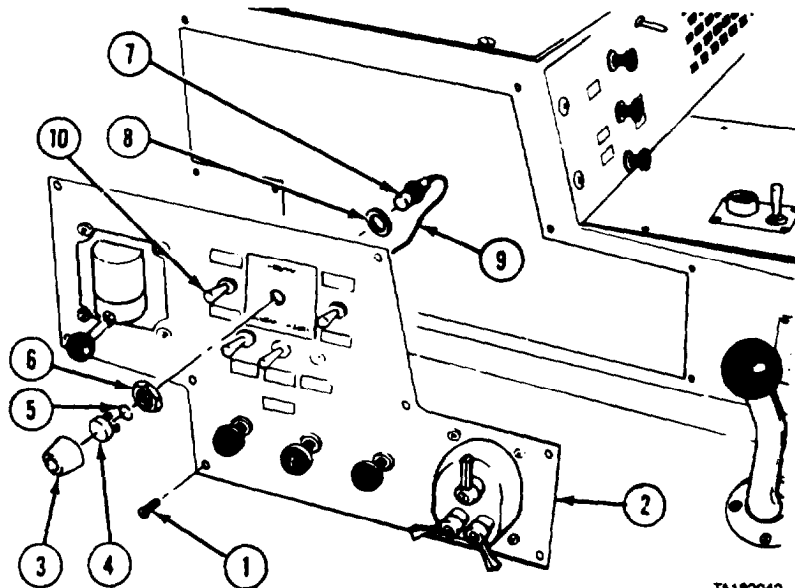
a. Removal.

- (1) Remove eight screws (1) and side panel (2).
- (2) Remove light shield (3). Remove lens (4) from light shield. Remove force ring (5) from lens.
- (3) Remove nut (6), indicator light (7), and washer (8) from side panel (2).

NOTE

Tag and mark wire before disconnecting.

- (4) Disconnect wire (9) attached to ON-OFF switch (10) and remove indicator light (7).



TA182042

6. Installation.

- (1) Connect wire (9) to indicator light (7) and ON-OFF switch (10).
- (2) Insert indicator light (7) and washer (8) through side panel (2) and install nut (6).
- (3) Install force ring (5) in lens (4). Install lens in light shield (3).
- (4) Position side panel (2) and make sure wire (9) is behind side panel. Install and tighten eight screws (1).

c. Follow-on Maintenance.

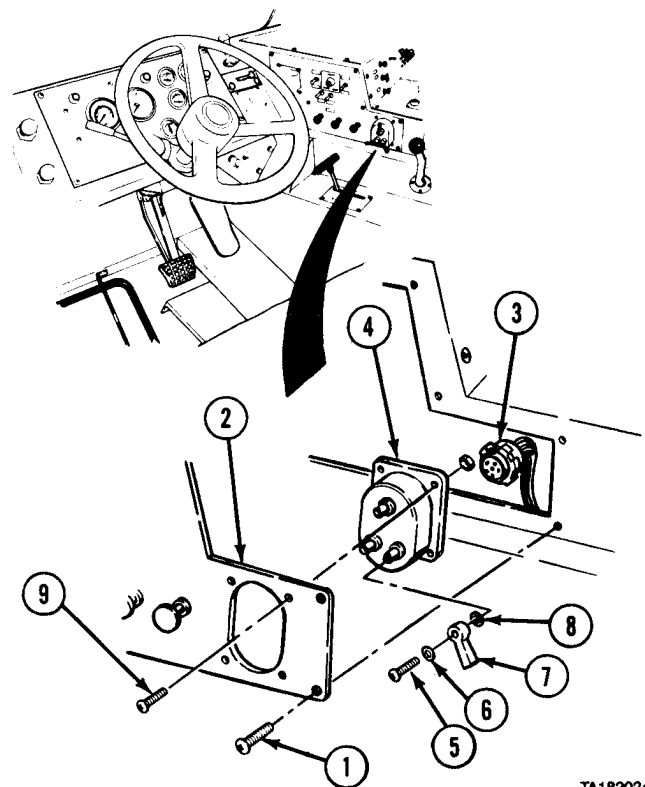
- (1) Connect batteries (para 7-91).
- (2) Check ENGINE BRAKE indicator light operation (TM 9-2320-279-10).

END OF TASK

Electrical System Maintenance Instructions (Cont)

| | |
|--|--|
| 7-41. MAIN LIGHT SWITCH REMOVAL/INSTALLATION. | |
| This task covers: | |
| a. Removal c. Follow-on Maintenance | b. Installation |
| INITIAL SETUP | |
| <i>Models</i> All | <i>References</i> None |
| <i>Test Equipment</i> None | <i>Equipment Condition</i> <i>TM or Para</i> <i>Condition Description</i> Para 7-91 Batteries disconnected. |
| <i>Special Tools</i> None | <i>Special Environmental Conditions</i> None |
| <i>Supplies</i> None | <i>General Safety Instructions</i> None |
| <i>Personnel Required</i> MOS 63S, Heavy wheel vehicle mechanic | |

- a. *Removal.*
- (1) Remove eight screws (1) and side panel (2).
 - (2) Disconnect plug (3) from main light switch (4).
 - (3) Remove three screws (5), washers (6), knobs (7), and washers (8) from main light switch (4).
 - (4) Remove four screws (9) and main light switch (4) from side panel (2).
- b. *Installation.*
- (1) Install four screws (9) and main light switch (4) in side panel (2).
 - (2) Install three screws (5), washers (6), knobs (7), and washers (8).
 - (3) Connect plug (3) to back of main light switch (4).
 - (4) Install side panel (2) and make sure all wires are behind side panel.
 - (5) Install and tighten eight screws (1).
- c. *Follow-on Maintenance.*
- (1) Connect batteries (para 7-91).
 - (2) Check operation of lights (TM 9-2320-279-10).



END OF TASK

TA182024

Electrical System Maintenance Instructions (Cont)

7-42. HEATER FAN SWITCH REMOVAL/INSTALLATION.

This task covers:

- a. Removal
- b. Installation
- c. Follow-on Maintenance

INITIAL SETUP

| | | | | | | | |
|---|--|-------------------|------------------------------|-----------|-------------------------|------------|-----------------------------------|
| <p><i>Models</i> All</p> <p><i>Test Equipment</i> None</p> <p><i>Special Tools</i> None</p> <p><i>Supplies</i> Tags, identification, Item 48, Appendix C</p> <p><i>Personnel Required</i> MOS 63S, Heavy wheel vehicle mechanic</p> | <p><i>References</i> None</p> <p><i>Equipment Condition</i></p> <table border="0"> <tr> <td style="padding-right: 20px;"><i>TM or Para</i></td> <td><i>Condition Description</i></td> </tr> <tr> <td>Para 7-91</td> <td>Batteries disconnected.</td> </tr> <tr> <td>Para 16-11</td> <td>Heater compartment cover removed.</td> </tr> </table> <p><i>Special Environmental Conditions</i> None</p> <p><i>General Safety Instructions</i> None</p> | <i>TM or Para</i> | <i>Condition Description</i> | Para 7-91 | Batteries disconnected. | Para 16-11 | Heater compartment cover removed. |
| <i>TM or Para</i> | <i>Condition Description</i> | | | | | | |
| Para 7-91 | Batteries disconnected. | | | | | | |
| Para 16-11 | Heater compartment cover removed. | | | | | | |

a. Removal.

- (1) Remove four screws (1).
- (2) Remove jamnut (2) and heater fan switch (3) from back of heater control panel (4).

NOTE

Tag and mark wires before disconnecting.

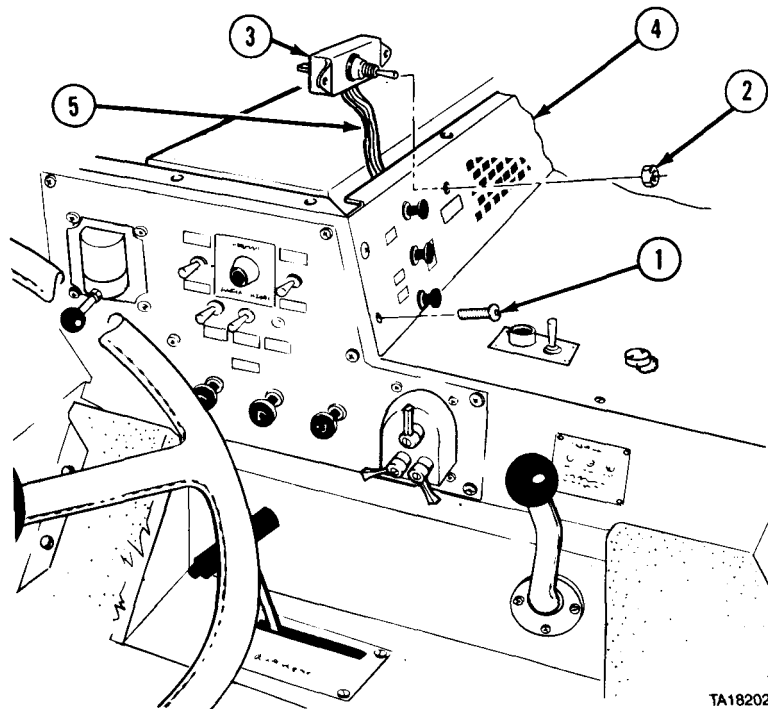
- (3) Disconnect wires (5) from heater fan switch (3).

b. Installation.

- (1) Connect wires (5) to heater fan switch (3).
- (2) Install heater fan switch (3) and jamnut (2) in heater control panel (4).
- (3) Install four screws (1).

c. Follow-on Maintenance.

- (1) Connect batteries (para 7-91).
- (2) Check operation of heater fan switch (TM 9-2320-279-10).
- (3) Install heater compartment cover (para 16-11).



TA182025

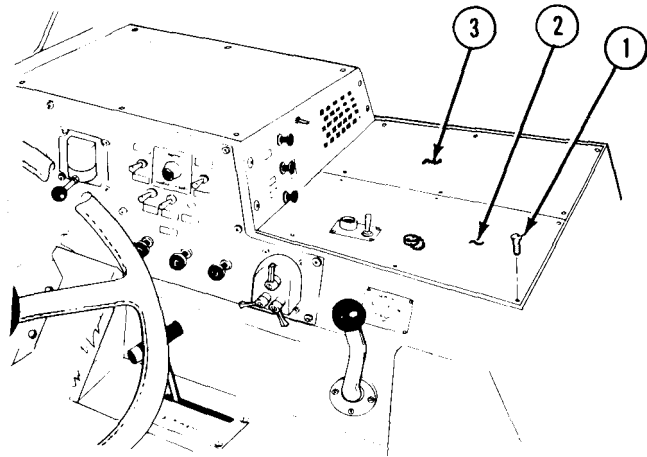
END OF TASK

Electrical System Maintenance Instructions (Cont)

| | |
|--|--|
| 7-43. CIRCUIT BREAKER (CENTER CONSOLE) REMOVAL/INSTALLATION. | |
| This task covers: | |
| a. Removal | b. Installation |
| c. Follow-on Maintenance | |
| INITIAL SETUP | |
| <i>Models</i> | <i>References</i> |
| All | None |
| <i>Test Equipment</i> | <i>Equipment Condition</i> |
| None | <i>TM or Para</i> <i>Condition Description</i> |
| <i>Special Tools</i> | Para 7-91 Batteries disconnected. |
| None | <i>Special Environmental Conditions</i> |
| <i>Supplies</i> | None |
| Tags, identification, Item 48, Appendix C | <i>General Safety Instructions</i> |
| <i>Personnel Required</i> | None |
| MOS 63S, Heavy wheel vehicle mechanic | |

a. Removal.

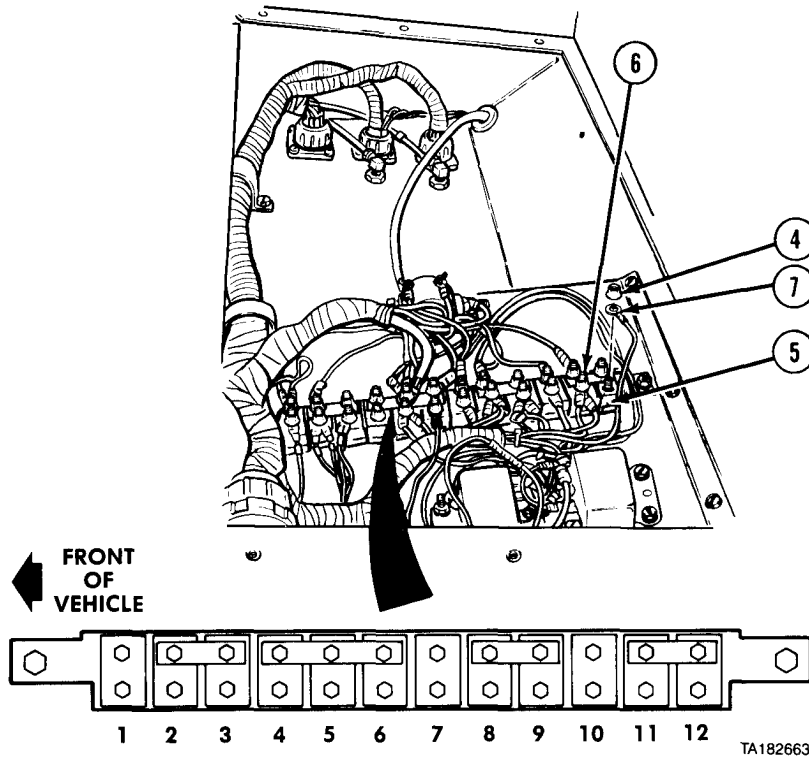
- (1) Remove 11 screws (1) and heater compartment covers (2 and 3).



TA182664

Electrical System Maintenance Instructions (Cont)

7-43. CIRCUIT BREAKER (CENTER CONSOLE) REMOVAL/INSTALLATION (CONT).



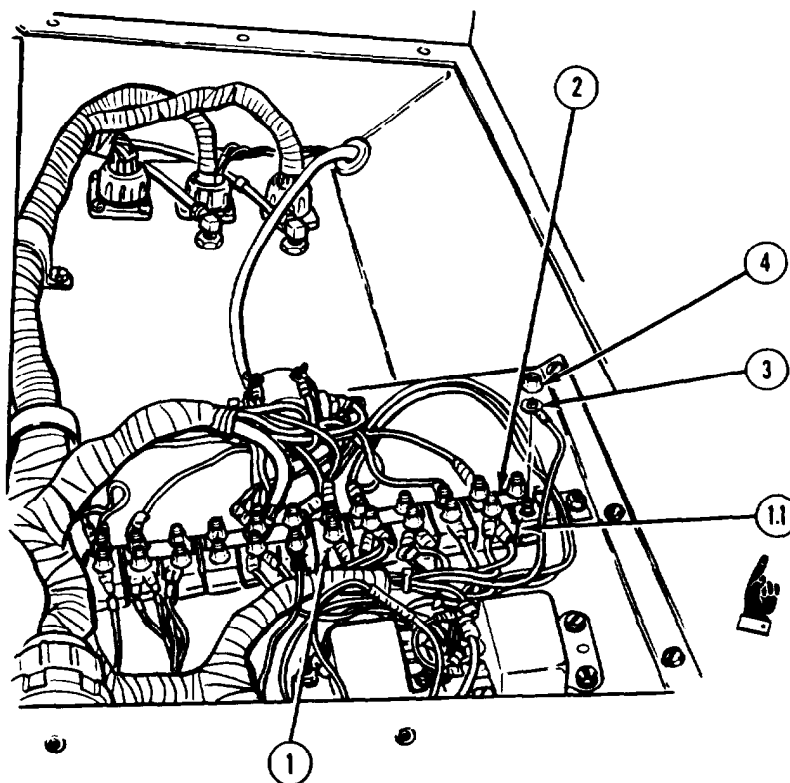
NOTE

- All 12 circuit breakers are removed in a similar manner.
- Tag and mark wires before removing.

- (2) Remove two nuts (4) and wires (5) from circuit breaker (6) to be replaced.
- (3) If there is bus bar (7), remove nuts (4), wires (5), and bus bar.
- (4) Snap out circuit breaker (6).
- (5) Repeat steps (2) through (4) if other circuit breakers are to be removed.

Electrical System Maintenance Instructions (Cont)

b. Installation.



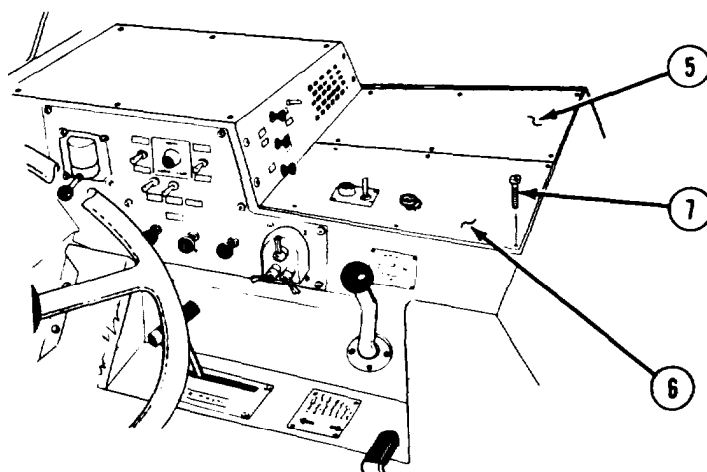
NOTE

- One circuit breaker requires special orientation at installation. Do step (1) and continue with step (2).
- Remaining 11 circuit breakers are installed in a similar manner. Do step (1.1) and continue with step (2).

- (1) Snap in circuit breaker (1) with short post to No. 084 wire (driver's side).
- (1.1) Snap in circuit breaker (1.1).
- (2) Install bus bar (2) if required.
- (3) Install wires (3).
- (4) Install two nuts (4) on circuit breaker (1) plus those required on bus bar (2).
- (5) Install heater compartment covers (5 and 6) with 11 screws (7).

c. Follow-on Maintenance. Connect batteries (para 7-91).

END OF TASK



Electrical System Maintenance Instructions (Cont)

7-44. CIRCUIT BREAKER RACK AND PANEL REMOVAL/INSTALLATION.

This task covers:

- a. Removal
- b. Installation
- c. Follow-on Maintenance

INITIAL SETUP

Models

All

Test Equipment

None

Special Tools

None

Supplies

None

Personnel Required

MOS 63S, Heavy wheel vehicle mechanic

References

None-

Equipment Condition

| TM or Para | Condition Description |
|------------|---------------------------|
| Para 7-43 | Circuit breakers removed. |
| Para 7-33 | Ignition relay removed. |
| Para 7-34 | Horn relay removed. |
| Para 7-35 | Magnetic switch removed. |

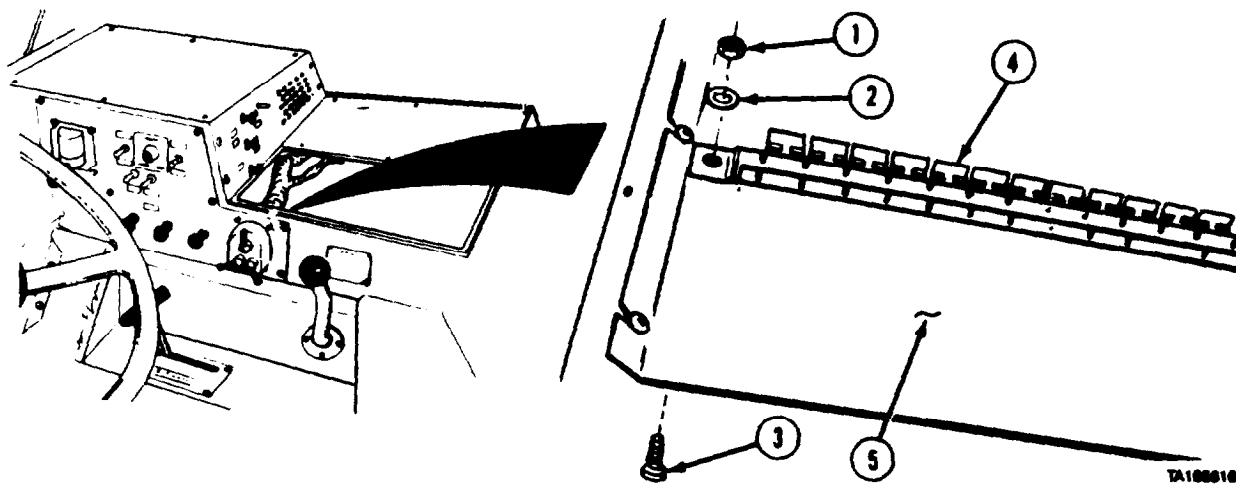
Special Environmental Conditions

None

General Safety Instructions

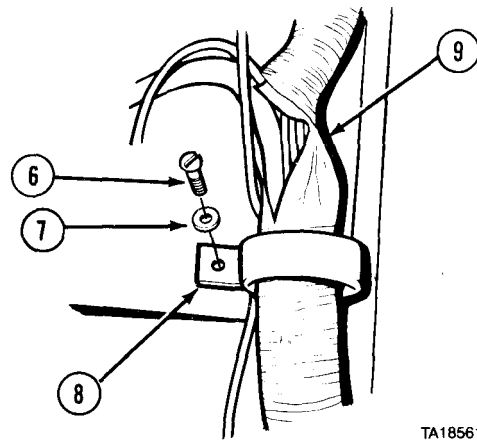
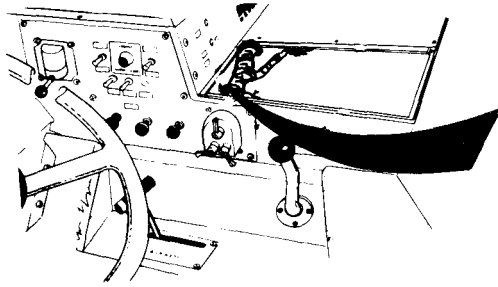
None

a. Removal.



- (1) Remove two locknuts (1), washers (2), and screws (3).
- (2) Remove circuit breaker rack (4) from circuit breaker plate (5).

Electrical System Maintenance Instructions (Cont)

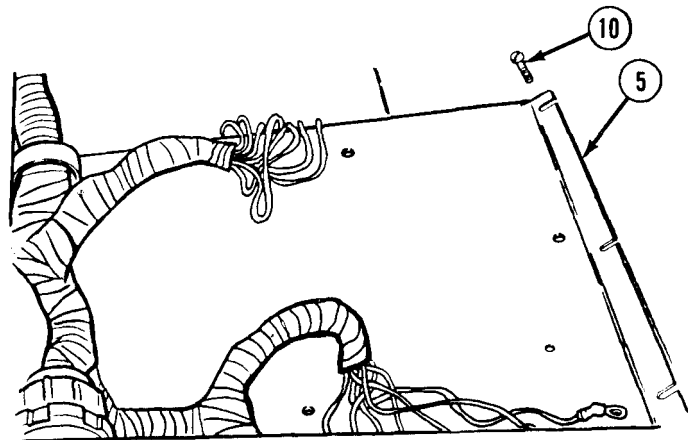


TA185617

(3) Remove two screws (6) and washers (7) from two cushion clips (8).

(4) Move cushion clips (8) and wiring harness (9) aside.

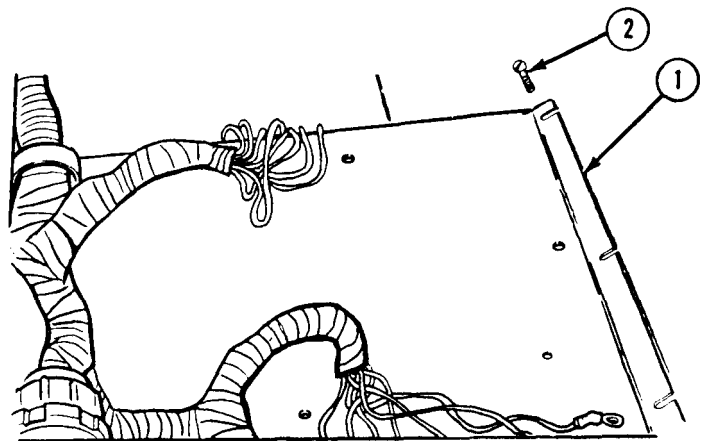
(5) Remove six screws (10) and circuit breaker plate (5).



TA185618

b. Installation.

(1) Install circuit breaker plate (1) with six screws (2).

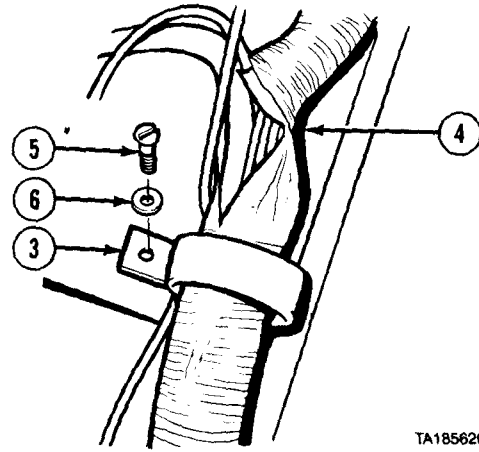


TA185619

Electrical System Maintenance Instructions (Cont)

7-44. CIRCUIT BREAKER RACK AND PANEL REMOVAL/INSTALLATION (CONT).

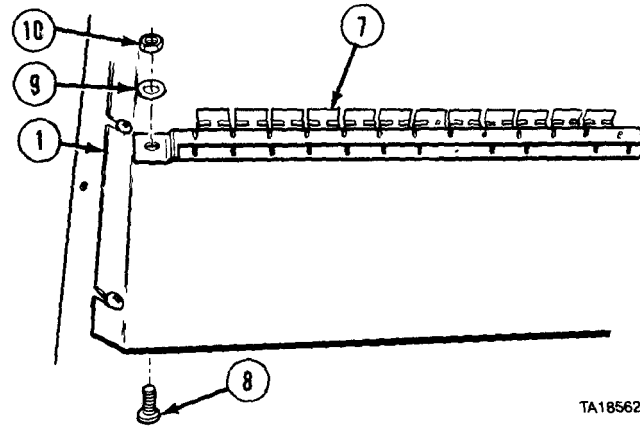
- (2) Install two cushion clips (3) on wiring harness (4) with two screws (5) and washers (6).



- (3) Install circuit breaker rack (7) on circuit breaker plate (1).
- (4) Install two screws (8), washers (9), and locknuts (10).

c. Follow-on Maintenance.

- (1) Install circuit breakers (para 7-43).
- (2) Install magnetic switch (para 7-35).
- (3) Install horn relay (para 7-34).
- (4) Install ignition relay (para 7-33).

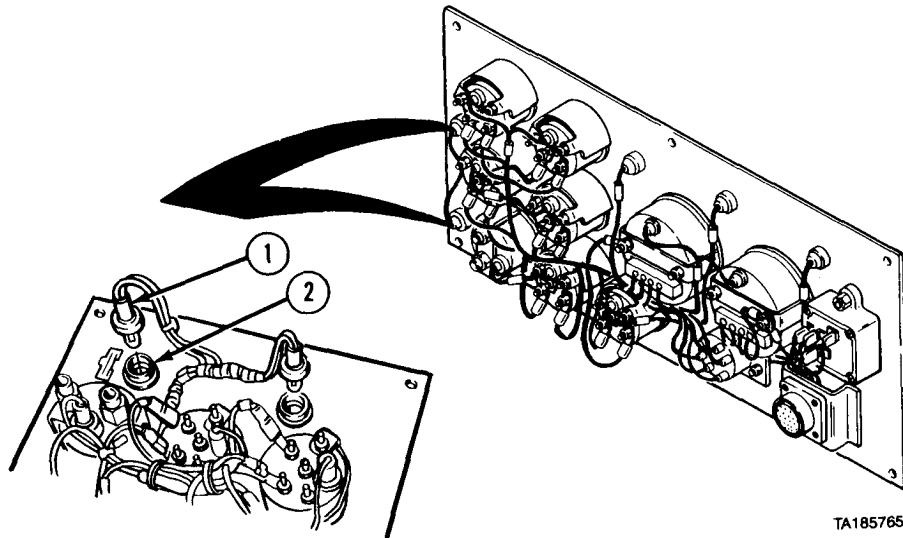


END OF TASK

Electrical System Maintenance Instructions (Cont)

| | |
|--|--|
| 7-45. INSTRUMENT PANEL HARNESS REMOVAL/INSTALLATION. | |
| This task covers: | |
| a. Removal | b. Installation |
| c. Follow-on Maintenance | |
| INITIAL SETUP | |
| <i>Models</i> | <i>References</i> |
| All | None |
| <i>Test Equipment</i> | <i>Equipment Condition</i> |
| None | <i>TM or Para</i> <i>Condition Description</i> |
| <i>Special Tools</i> | Para 7-19 Instrument panel removed. |
| None | <i>Special Environmental Conditions</i> |
| <i>Supplies</i> | None |
| Tags, identification, Item 48, Appendix C | <i>General Safety Instructions</i> |
| <i>Personnel Required</i> | None |
| MOS 63S, Heavy wheel vehicle mechanic | |

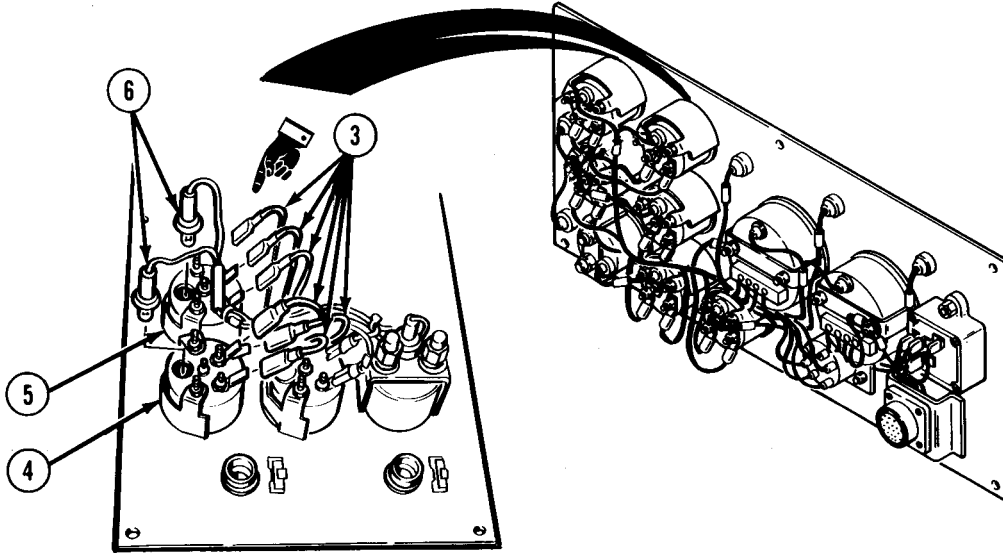
a. Removal.



(1) Remove two warning indicator light sockets (1) from receptacles (2).

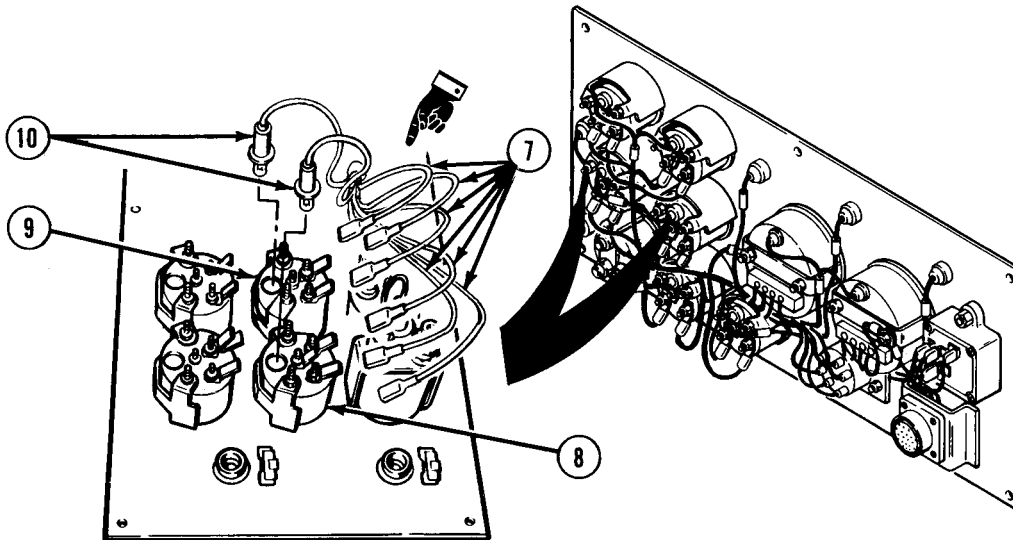
Electrical System Maintenance Instruction (Cont)

7-45. INSTRUMENT PANEL HARNESS REMOVAL/INSTALLATION (CONT).



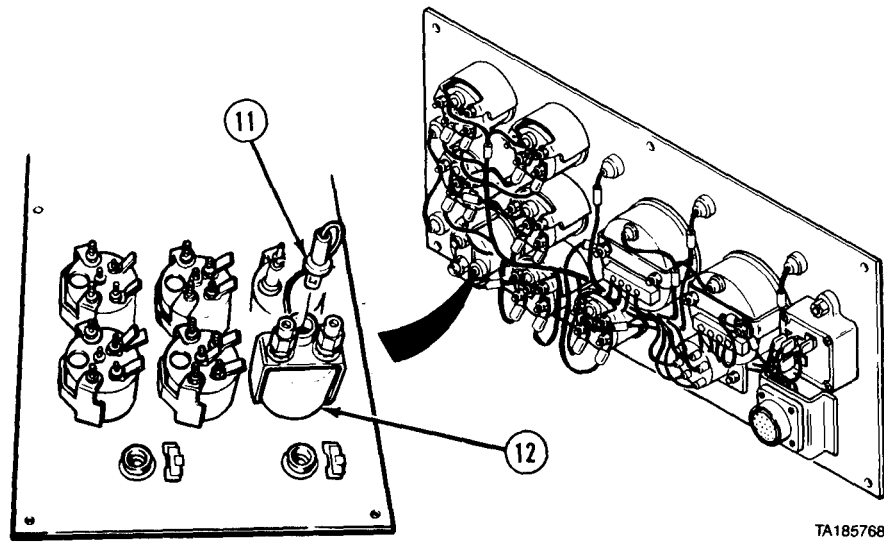
NOTE

- Tag and mark wires before disconnecting.
 - Some trucks have five wires, some trucks have six.
- (2) Disconnect six wires (3) from OIL PRESS gage (4) and FUEL gage (5).
 (3) Remove two light sockets (6) from gages (4 and 5).

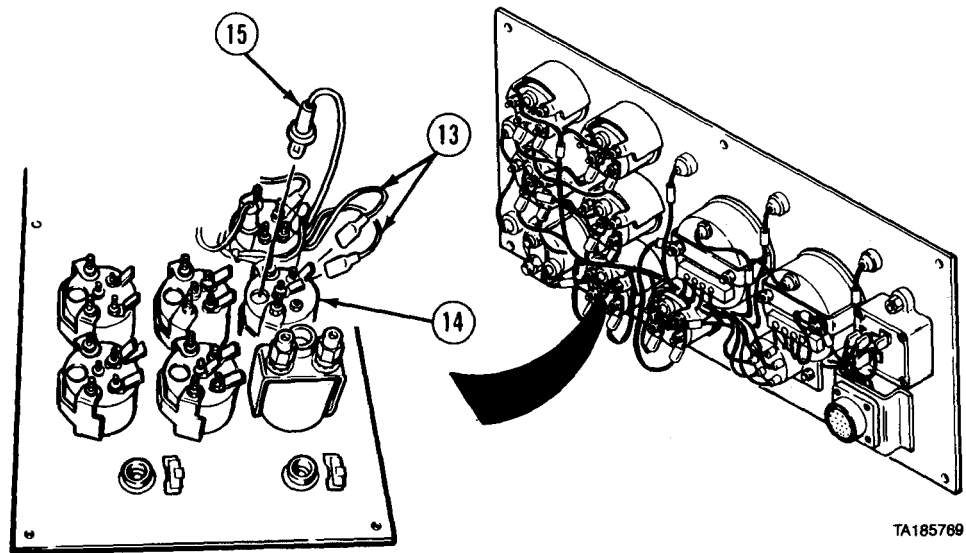


- (4) Disconnect six wires (7) from water temperature gage (8) and transmission oil temperature gage (9).
 (5) Remove two light sockets (10) from gages (8 and 9).

Electrical System Maintenance Instructions (Cont)



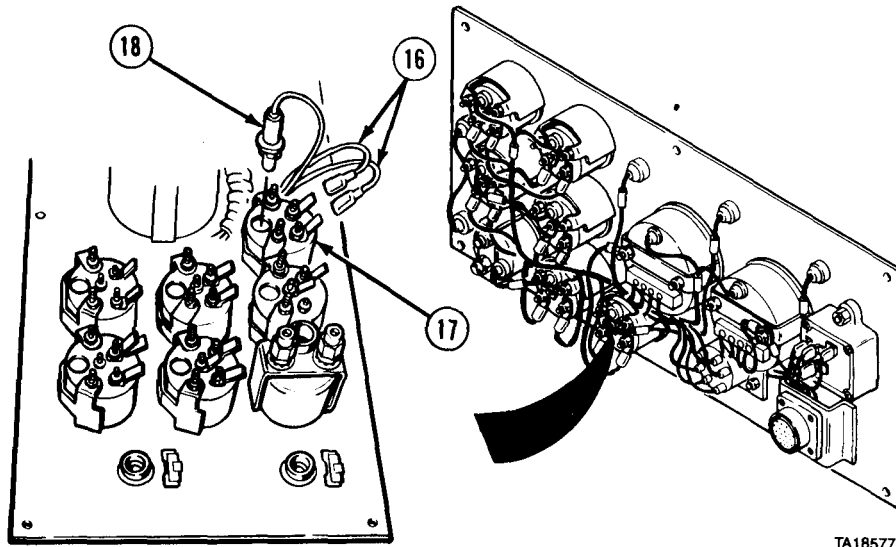
(6) Remove light socket (11) from AIR PRESS gage (12).



(7) Disconnect two wires (13) from BATTERY gage (14).
 (8) Remove light socket (15) from BATTERY gage (14).

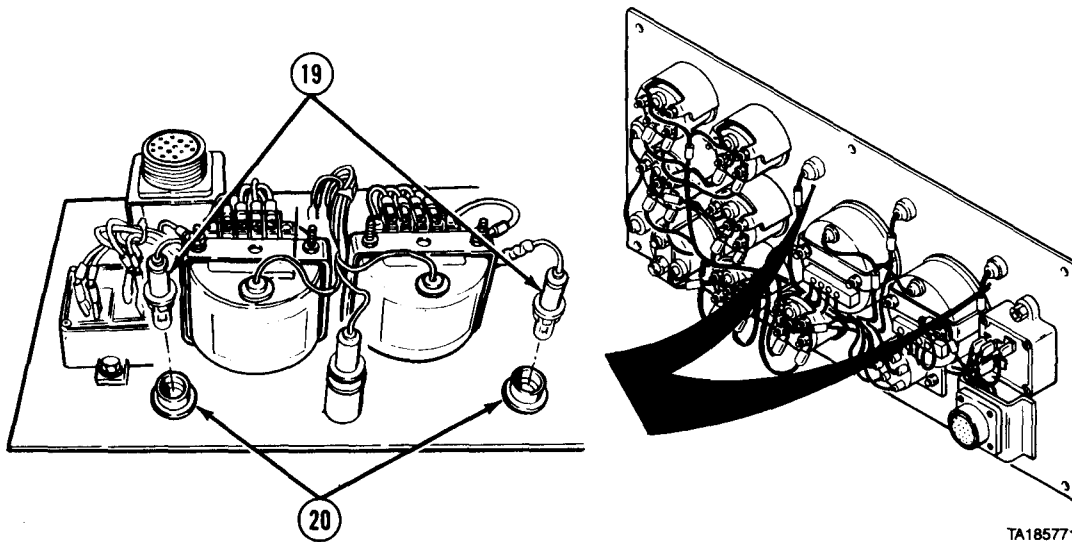
Electrical System Maintenance Instructions (Cont)

7-45. INSTRUMENT PANEL HARNESS REMOVAL/INSTALLATION (CONT.)



TA185770

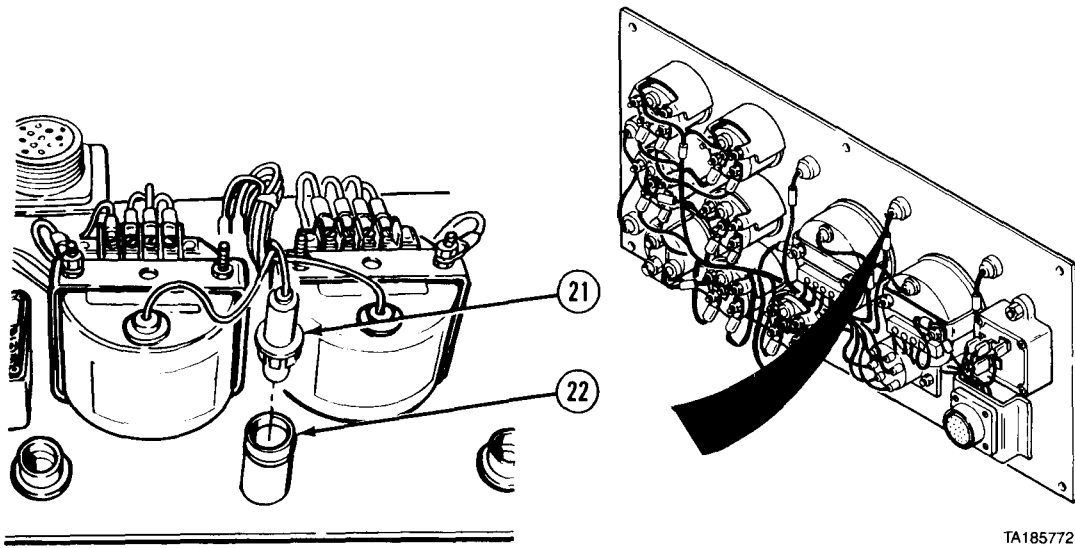
- (9) Disconnect two wires (16) from AMPERES gage (17).
- (10) Remove light socket (18) from AMPERES gage (17).



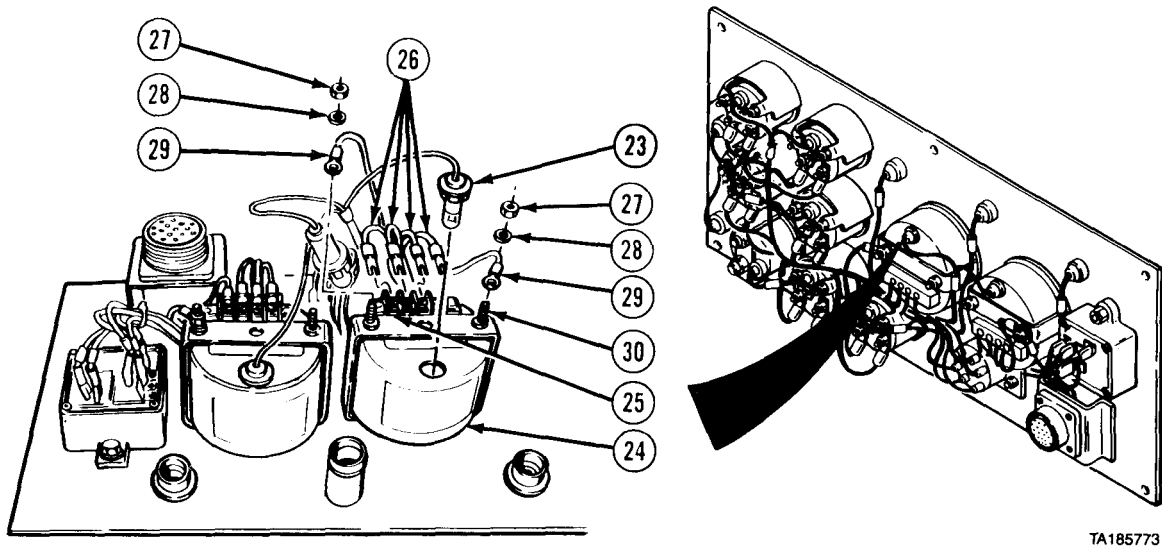
TA185771

- (11) Remove two turn indicator light sockets (19) from receptacles (20).

Electrical System Maintenance Instructions (Cont)



(12) Remove high beam indicator light socket (21) from receptacle (22).



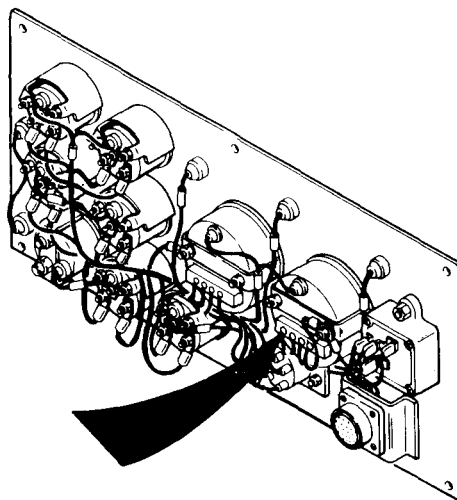
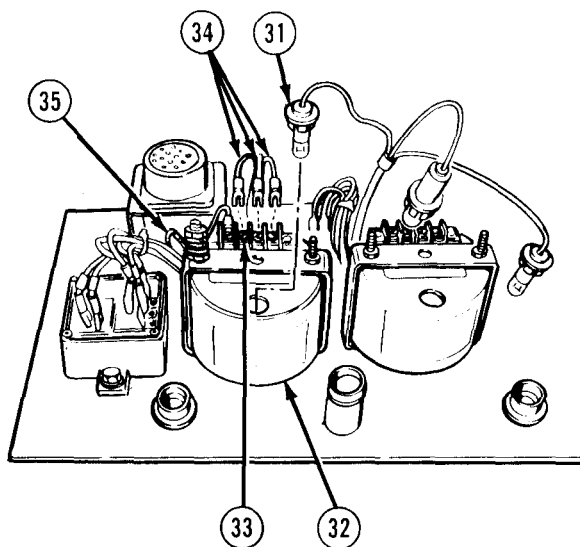
(13) Remove light socket (23) from tachometer/hourmeter (24).

(14) Loosen four screws (25) and disconnect four wires (26) from back of tachometer/hourmeter (24).

(15) Remove two nuts (27), lockwashers (28), and ground wires (29) from posts (30).

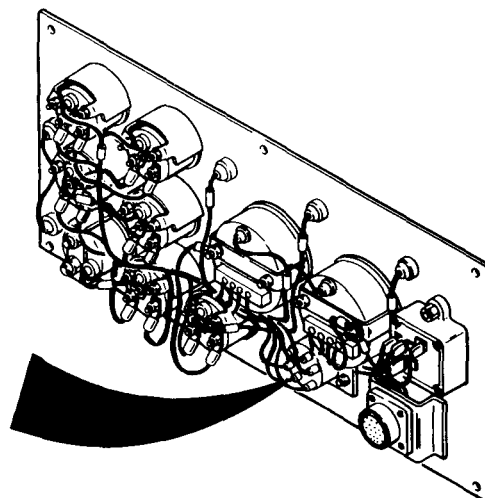
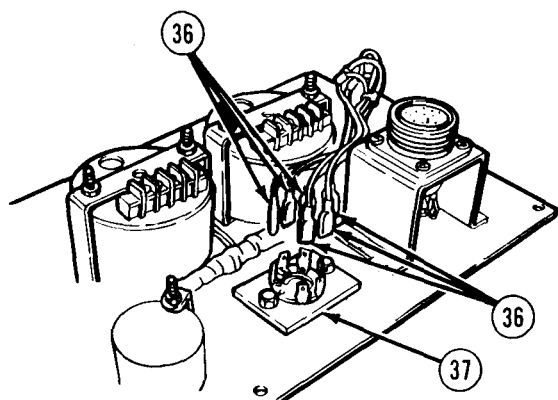
Electrical System Maintenance Instructions (Cont)

7-45. INSTRUMENT PANEL HARNESS REMOVAL/INSTALLATION (CONT).



TA185774

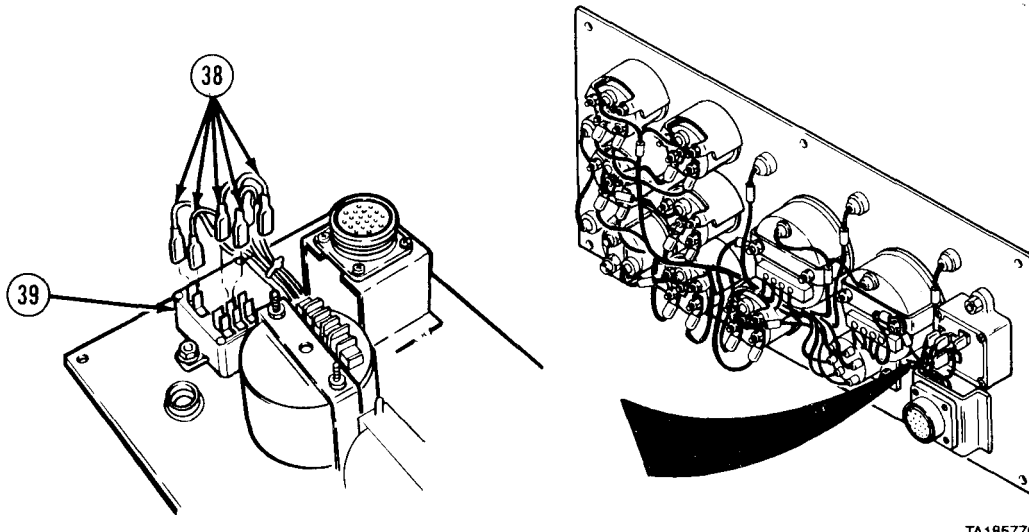
- (16) Remove light socket (31) from speedometer/odometer (32).
- (17) Loosen three screws (33) and disconnect three wires (34) from back of speedometer/odometer (32).
- (18) Remove wire (35) from speedometer/odometer (32).



TA185775

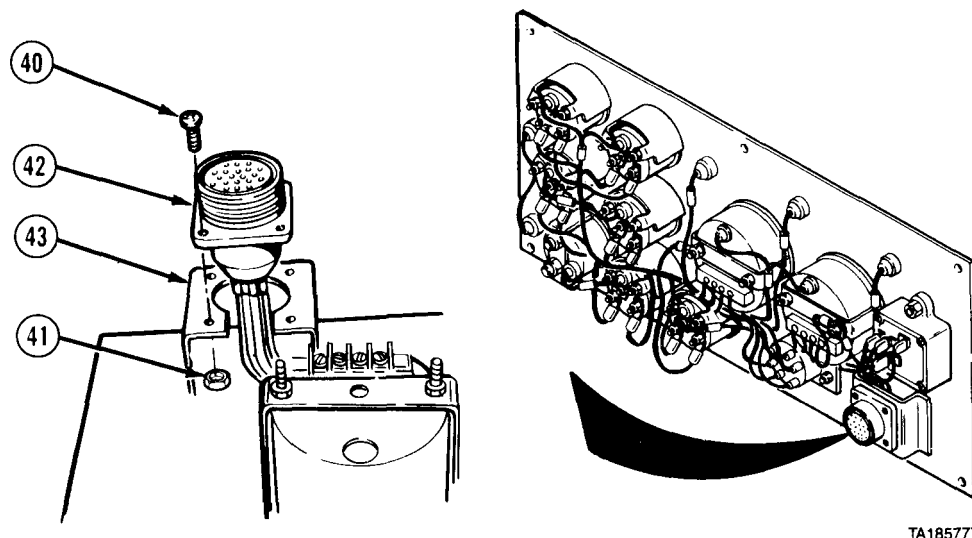
- (19) Disconnect six wires (36) from junction block (37).

Electrical System Maintenance Instructions (Cont)



TA185776

(20) Disconnect six wires (38) from system buzzer (39).



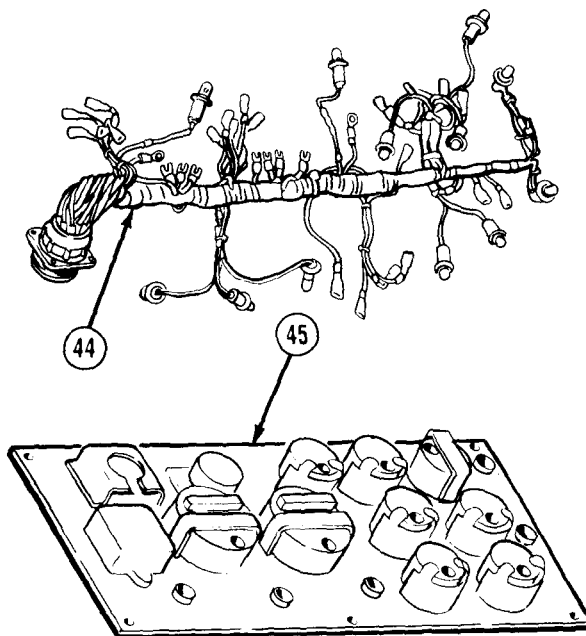
TA185777

(21) Remove four screws (40) and locknuts (41) from receptacle (42).
 (22) Remove receptacle (42) from bracket (43).

Electrical System Maintenance Instructions (Cont)

7-45. INSTRUMENT PANEL HARNESS REMOVAL/INSTALLATION (CONT).

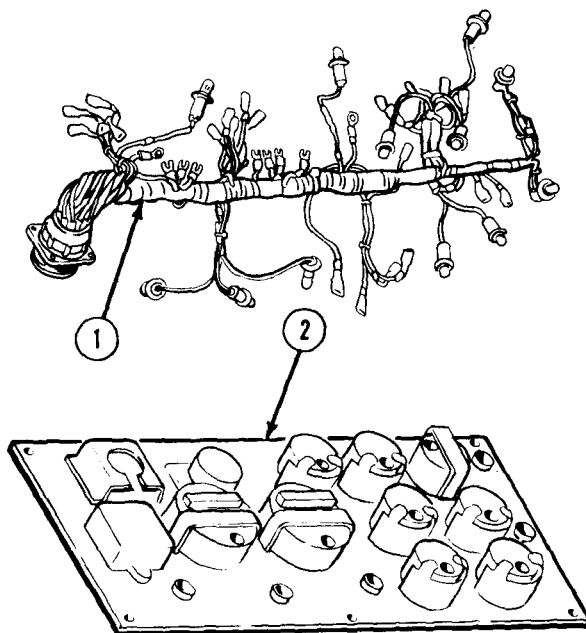
(23) Remove wiring harness (44) from instrument panel (45).



TA185778

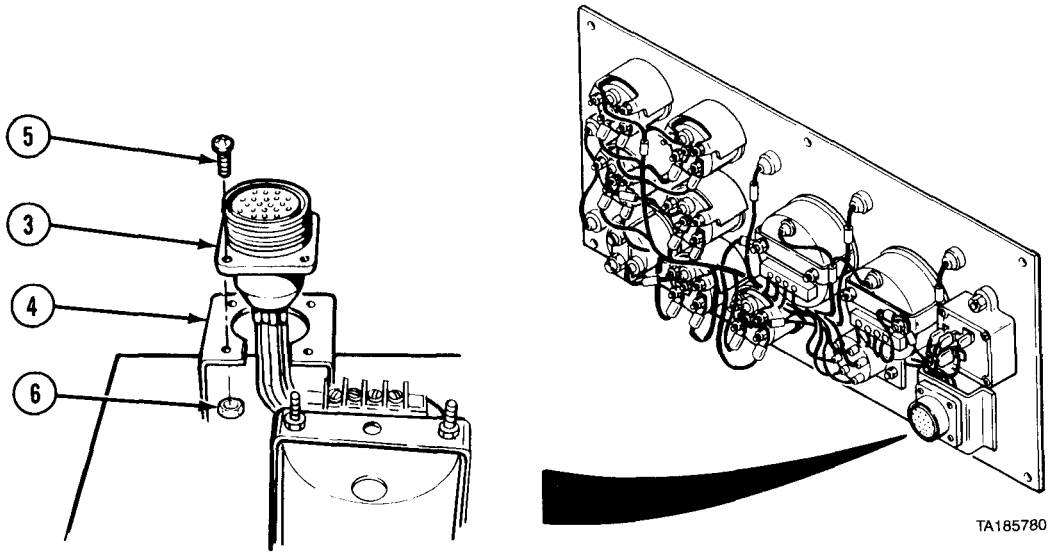
b. Installation.

(1) Position wiring harness (1) in instrument panel (2).

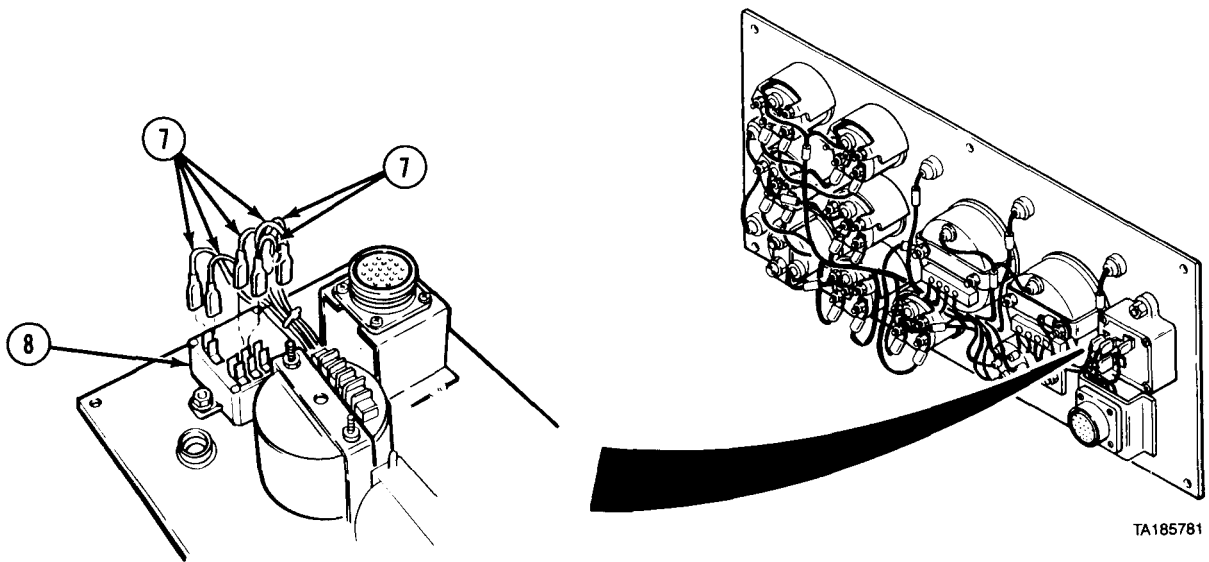


TA185779

Electrical System Maintenance Instructions (Cont)



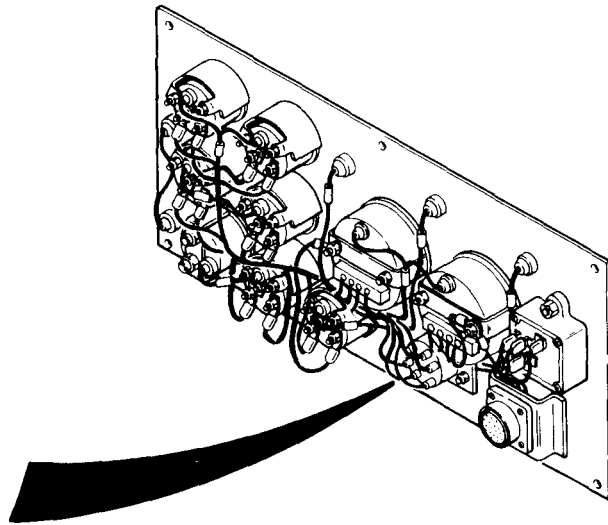
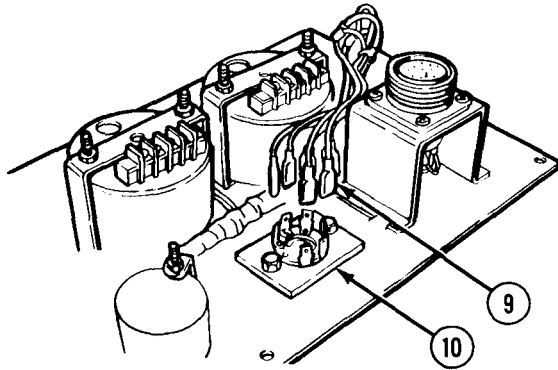
(2) Install receptacle (3) in bracket (4) with four screws (5) and locknuts (6).



(3) Connect six wires (7) to system buzzer (8).

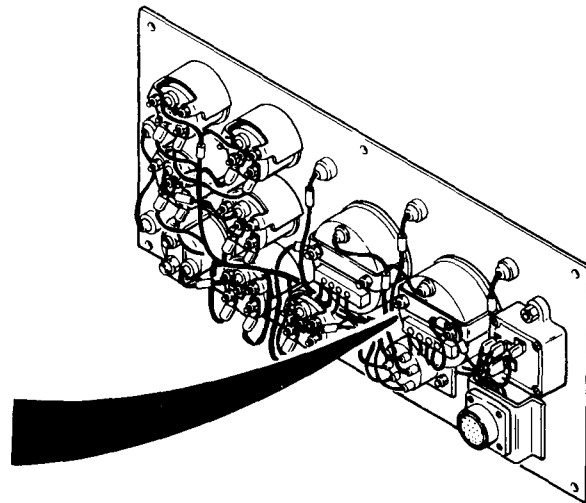
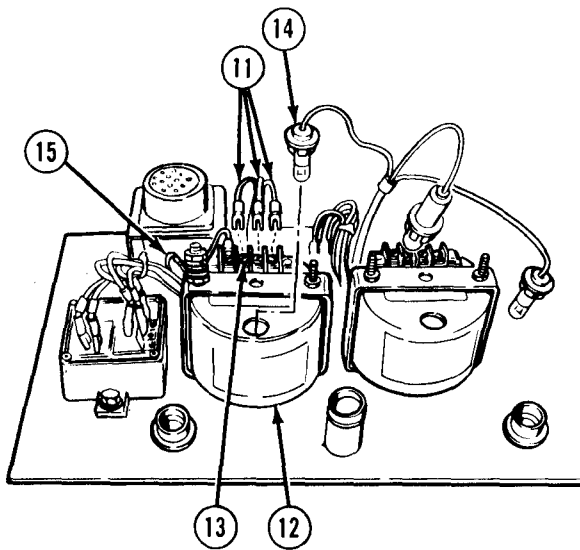
Electrical System Maintenance Instructions (Cont)

7-45. INSTRUMENT PANEL HARNESS REMOVAL/INSTALLATION (CONT).



TA185782

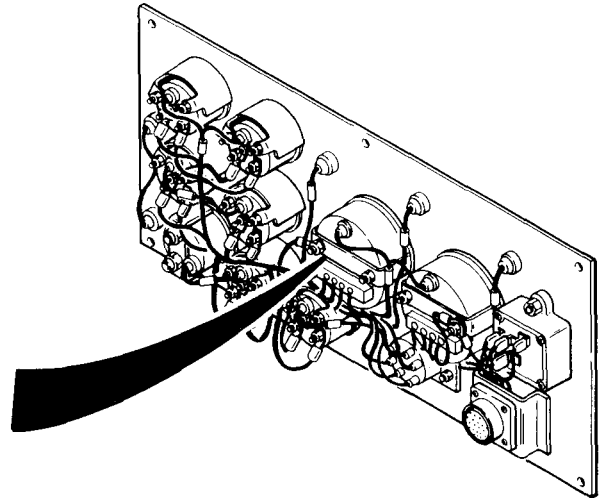
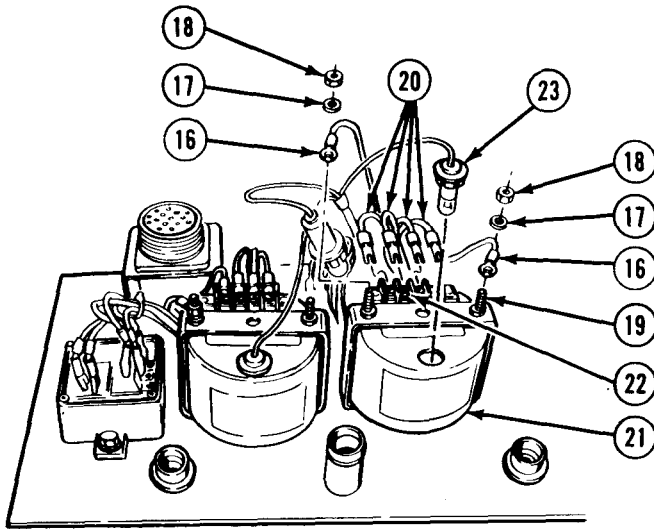
(4) Connect six wires (9) to junction block (10).



TA185764

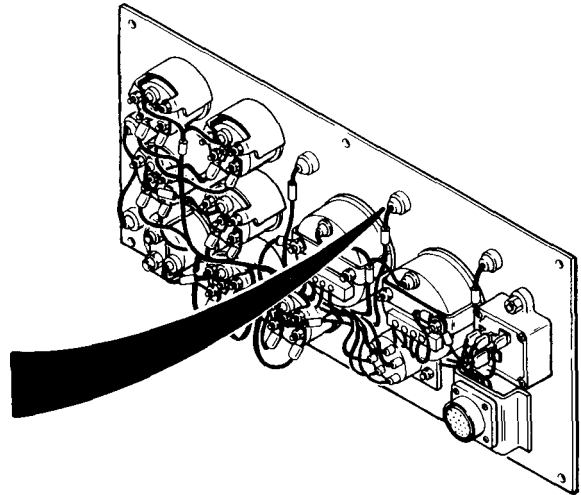
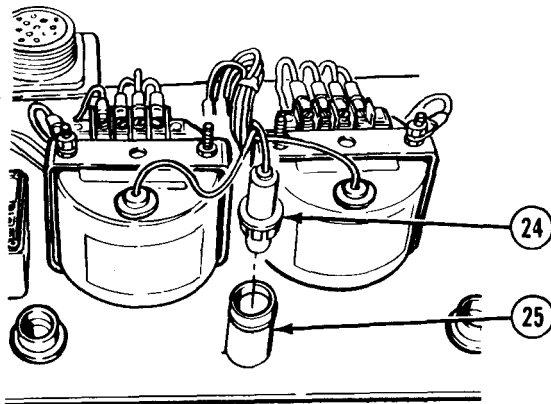
- (5) Connect three wires (11) to back of speedometer/odometer (12). Tighten three screws (13).
- (6) Install light socket (14).
- (7) Connect wire (15) to speedometer/odometer (12).

Electrical System Maintenance Instructions (Cont)



TA185783

- (8) Install two ground wires (16), lockwashers (17), and nuts (18) on posts (19).
- (9) Connect four wires (20) to tachometer/hourmeter (21). Tighten four screws (22).
- (10) Install light socket (23) in tachometer/hourmeter (21).

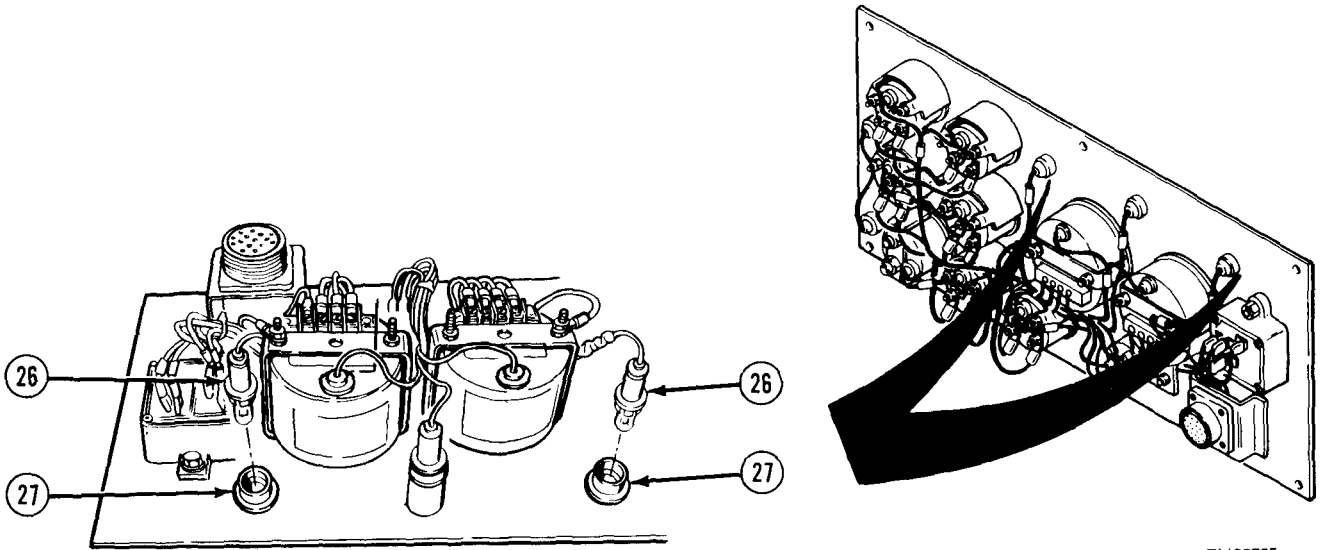


TA185784

- (11) Install high beam indicator light socket (24) in receptacle (25).

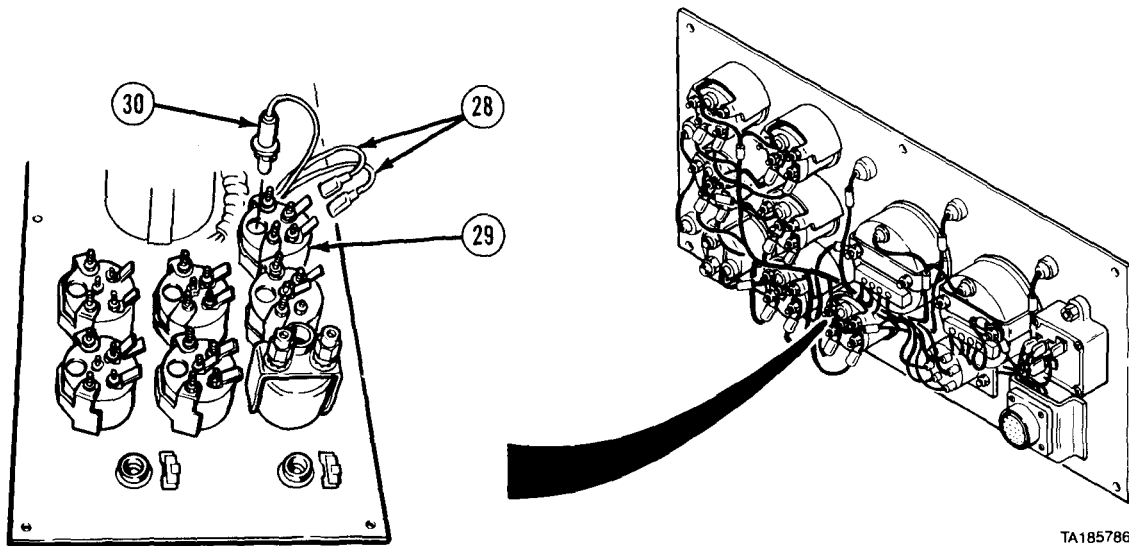
Electrical System Maintenance Instructions (Cont)

7-45. INSTRUMENT PANEL HARNESS REMOVAL/INSTALLATION (CONT).



TA185785

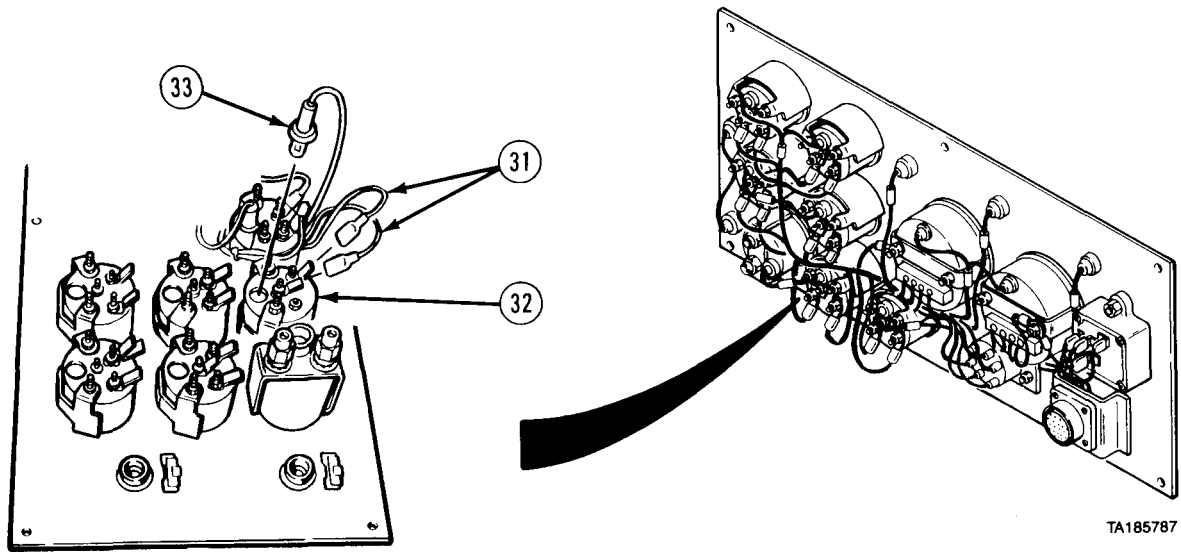
(12) Install two turn indicator light sockets (26) in receptacles (27).



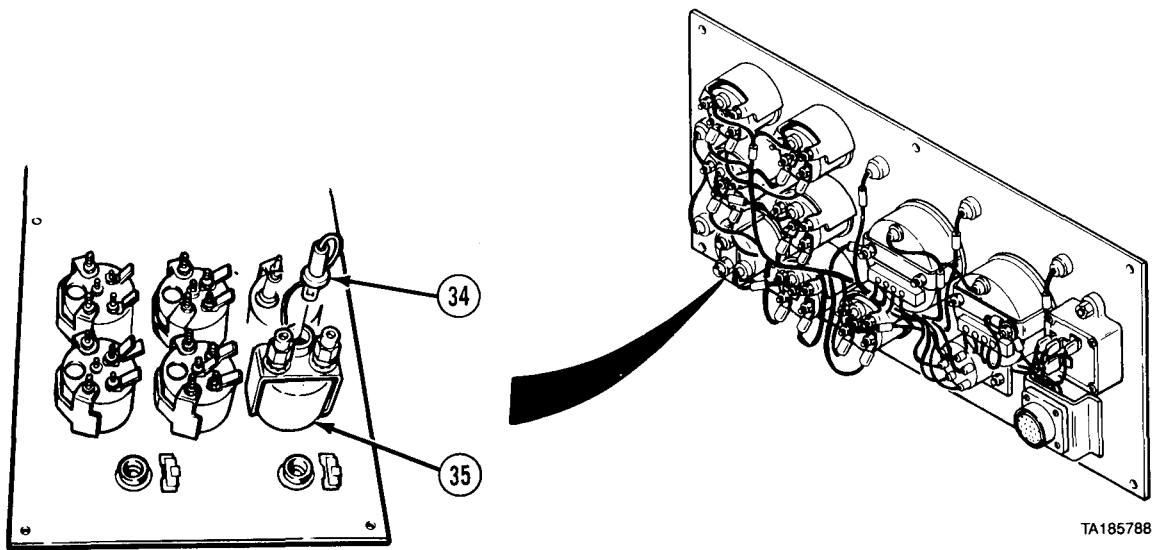
TA185786

(13) Connect two wires (28) to AMPERES gage (29).
(14) Install light socket (30) in AMPERES gage (29).

Electrical System Maintenance Instructions (Cont)



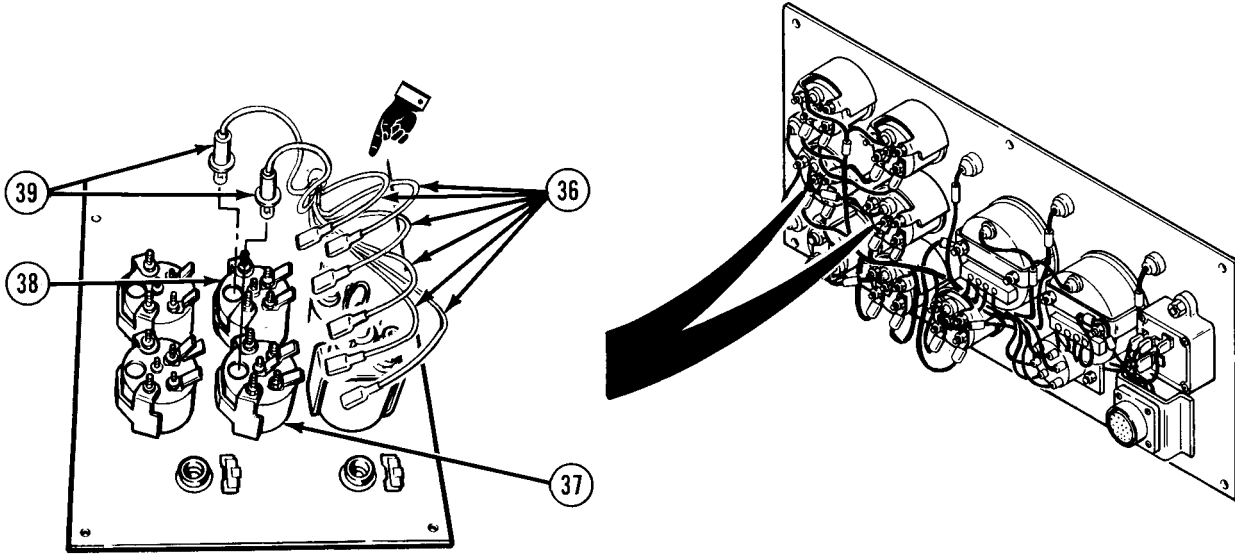
- (15) Connect two wires (31) to BATTERY gage (32).
- (16) Install light socket (33) in BATTERY gage (32).



- (17) Install light socket (34) in AIR PRESS gage (35).

Electrical System Maintenance Instruction (Cont)

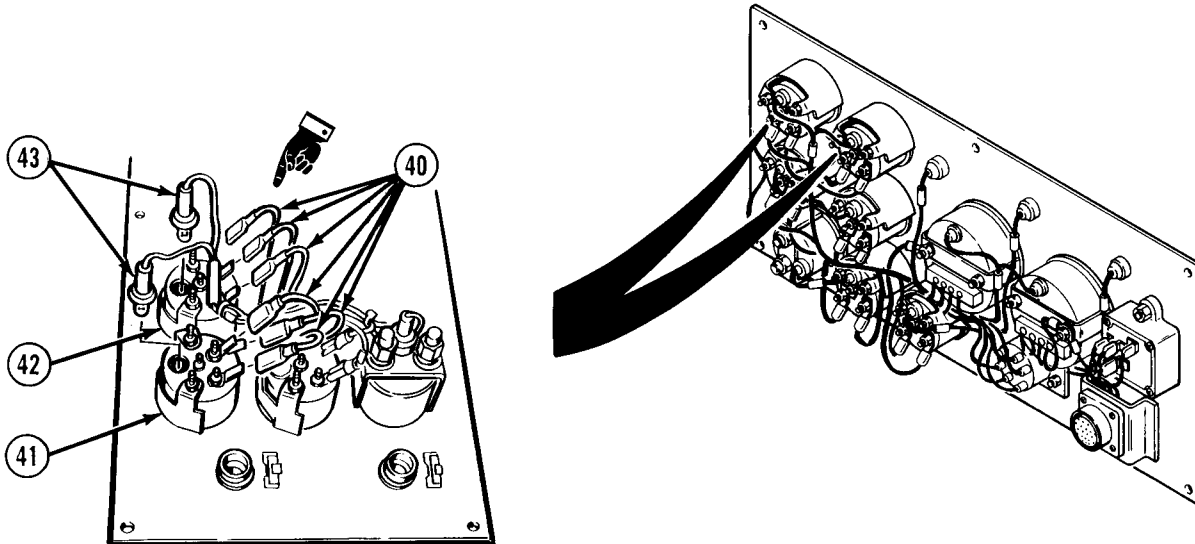
7-45. INSTRUMENT PANEL HARNESS REMOVAL/INSTALLATION (CONT).



NOTE

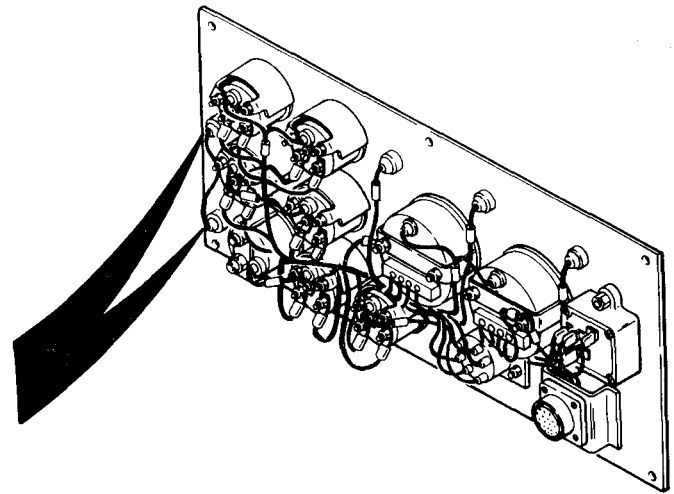
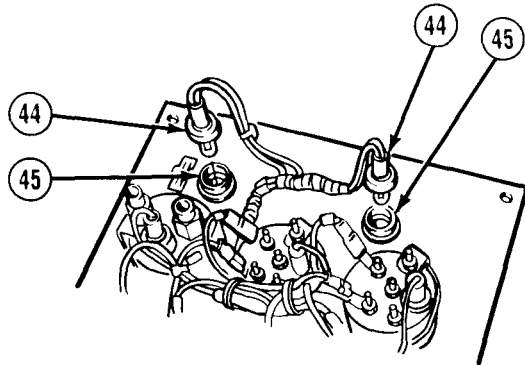
Some trucks have five wires, some trucks have six.

- (18) Connect six wires (36) to water temperature gage (37) and transmission oil temperature gage (38).
- (19) Install two light sockets (39) in gages (37 and 38).



- (20) Connect six wires (40) to OIL PRESS gage (41) and FUEL gage (42).
- (21) Install two light sockets (43) in gages (41 and 42).

Electrical System Maintenance Instructions (Cont)



TA185791

- (22) Install two warning indicator light sockets (44) in receptacles (45).
- c. *Follow-on Maintenance.* Install instrument panel (para 7-19).

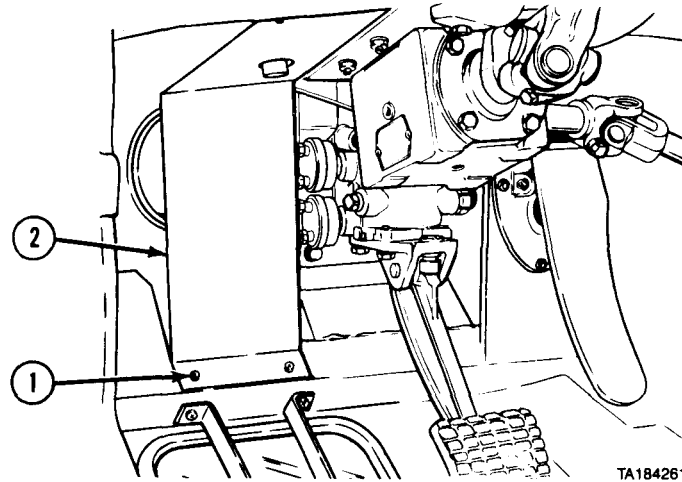
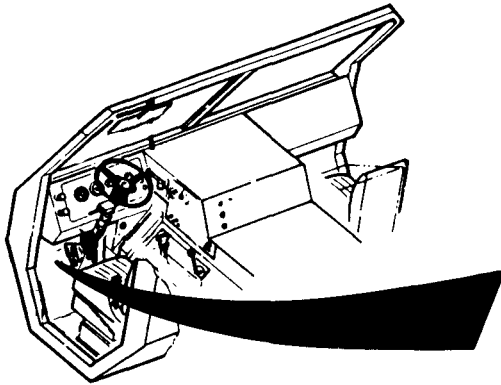
END OF TASK

| | | | | | | | |
|---|--|-------------------|------------------------------|------------------|---------------------|-----------|-------------------------|
| 7-46. BRAKE TREADLE VALVE STOPLIGHT SWITCH REMOVAL/INSTALLATION. | | | | | | | |
| This task covers: | | | | | | | |
| <ul style="list-style-type: none"> a. Removal b. Installation | <ul style="list-style-type: none"> c. Follow-on Maintenance | | | | | | |
| INITIAL SETUP | | | | | | | |
| <p><i>Models</i> All</p> <p><i>Test Equipment</i> None</p> <p><i>Special Tools</i> None</p> <p><i>Supplies</i> Compound, sealing, pipe thread, Item 18, Appendix C Tags, identification, Item 48, Appendix C</p> <p><i>Personnel Required</i> MOS 63S, Heavy wheel vehicle mechanic</p> | <p><i>References</i> None</p> <p><i>Equipment Condition</i></p> <table border="0"> <tr> <td><i>TM or Para</i></td> <td><i>Condition Description</i></td> </tr> <tr> <td>TM 9-2320-279-10</td> <td>Air system drained.</td> </tr> <tr> <td>Para 7-91</td> <td>Batteries disconnected.</td> </tr> </table> <p><i>Special Environmental Conditions</i> None</p> <p><i>General Safety Instructions</i> Wheels chocked.</p> | <i>TM or Para</i> | <i>Condition Description</i> | TM 9-2320-279-10 | Air system drained. | Para 7-91 | Batteries disconnected. |
| <i>TM or Para</i> | <i>Condition Description</i> | | | | | | |
| TM 9-2320-279-10 | Air system drained. | | | | | | |
| Para 7-91 | Batteries disconnected. | | | | | | |

Electrical System Maintenance Instructions (Cont)

7-46. BRAKE TREADLE VALVE STOPLIGHT SWITCH REMOVAL/INSTALLATION (CONT).

a. Removal.



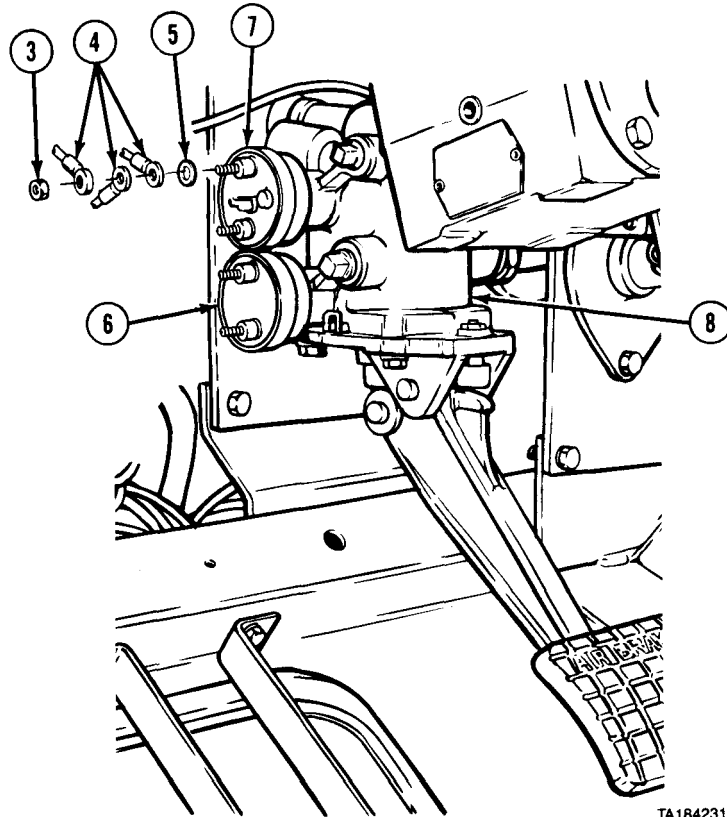
TA184261

(1) Remove four screws (1) and light guard (2).

NOTE

Tag and mark wires before removal.

- (2) Remove four nuts (3), nine wires (4), and four washers (5) from stoplight switches (6 and 7).
- (3) Remove stoplight switches (6 and 7) from brake treadle valve (8).



TA184231

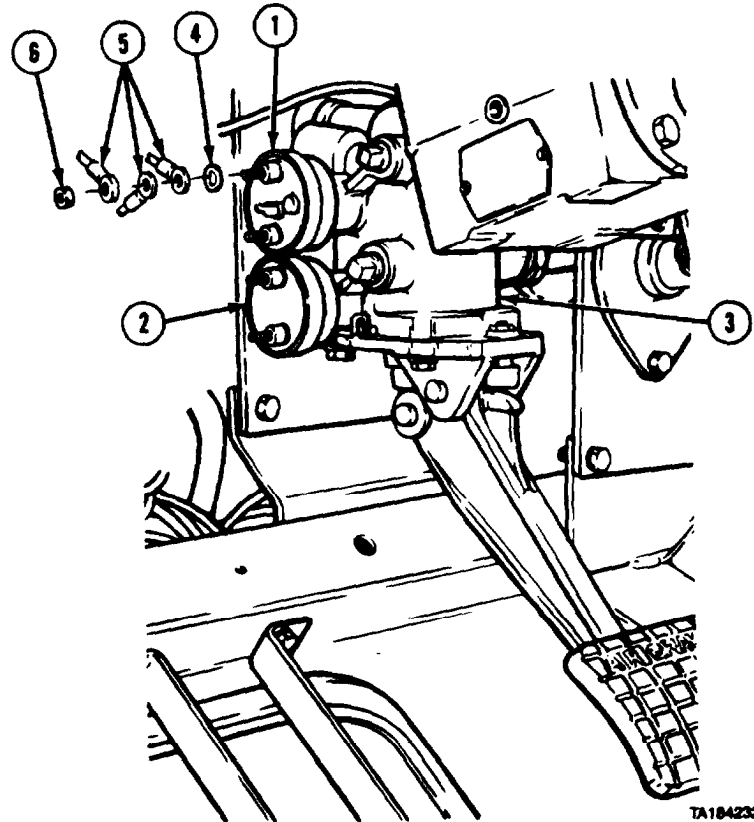
Electrical System Maintenance Instructions (Cont)

b. Installation.

WARNING

Adhesives, solvents, and sealing compounds can burn easily, can give off harmful vapors, and are harmful to skin and clothing. To avoid injury or death, keep away from open fire and use in well-ventilated area. If adhesive, solvent, or sealing compound gets on skin or clothing, wash immediately with soap and water.

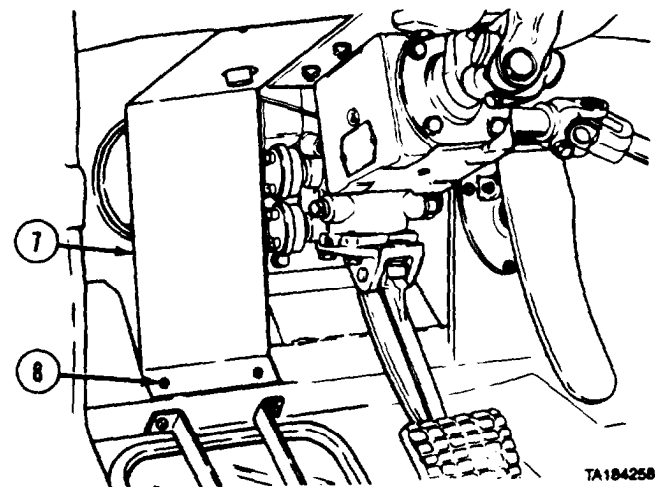
- (1) Coat threads of stoplight switches (1 and 2) with pipe thread sealing compound.
- (2) Install stoplight switches (1 and 2) in brake treadle valve (3).
- (3) Install four washers (4), nine wires (5), and four nuts (6).



- (4) Install light guard (7) with four screws (8).

c. Follow-on Maintenance.

- (1) Connect batteries (para 7-91).
- (2) Start engine and build up air pressure (TM 9-2320-279-10).
- (3) Check operation of stoplight switches (TM 9-2320-279-10).
- (4) Shut off engine (TM 9-2320-279-10).



END OF TASK

Electrical System Maintenance Instructions (Cont)

Section VI. JUNCTION BOXES

7-47. MAIN JUNCTION BOX ASSEMBLY REMOVAL/INSTALLATION.

This task covers:

- a. Removal
- b. Installation
- c. Follow-on Maintenance

INITIAL SETUP

Models

M978

Test Equipment

None

Special Tools

None

Supplies

Adhesive-sealant, silicone, Item 4, Appendix C
 Tags, identification, Item 48, Appendix C
 Compound, sealing, pipe thread, Item 18, Appendix C

Personnel Required

MOS 63S, Heavy wheel vehicle mechanic

References

None

Equipment Condition

| | |
|-------------------|------------------------------|
| <i>TM or Para</i> | <i>Condition Description</i> |
| Para 7-91 | Batteries disconnected. |

Special Environmental Conditions

None

General Safety Instructions

No smoking, flame, sparks, and hot or glowing objects within 50 ft (15 m) of vehicle.

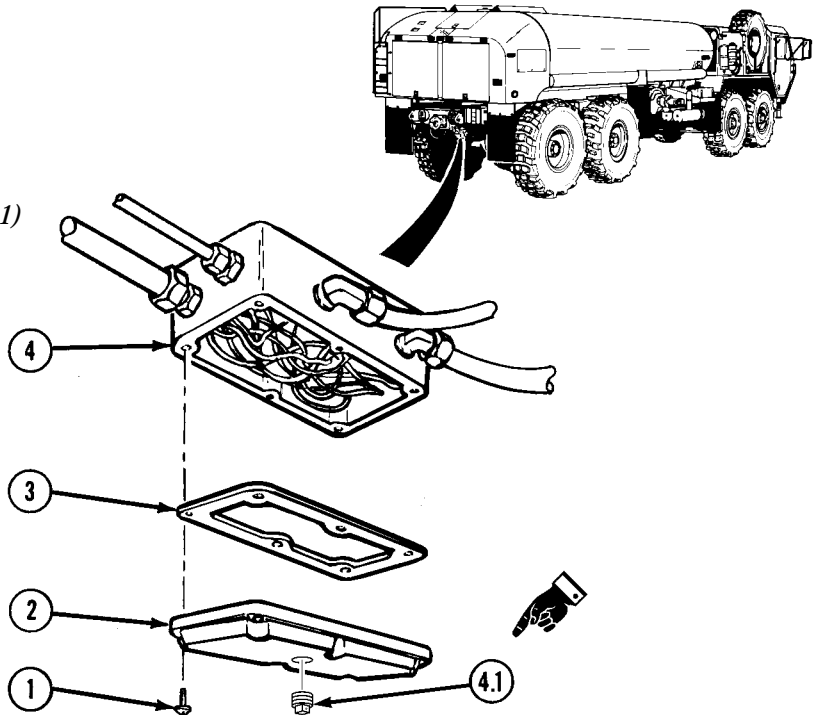
a. Removal.

- (1) Remove six screws (1), cover (2), and gasket (3) from main junction box (4).

NOTE

Some covers have a plug. Do step (1.1) for these covers.

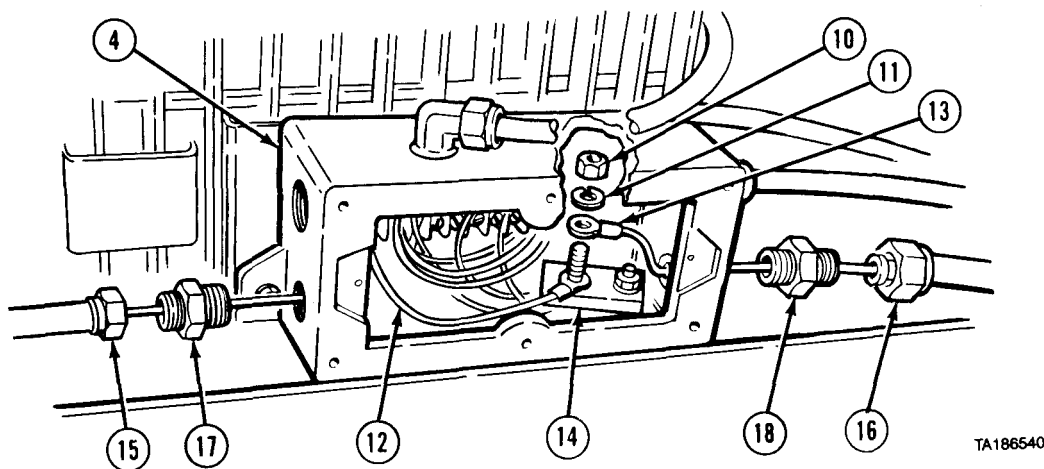
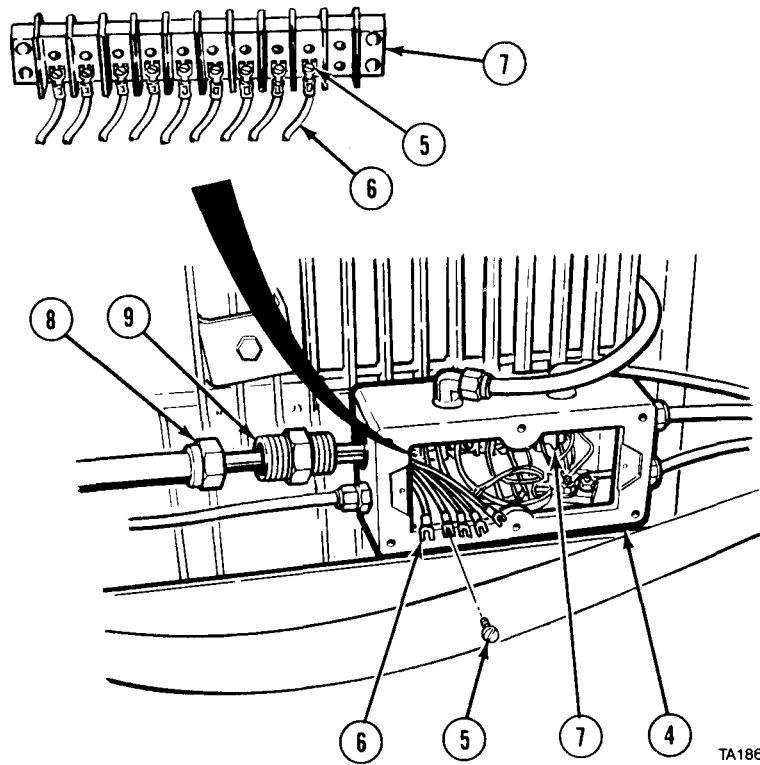
- (1.1) Remove plug (4.1) from cover (2).



Electrical System Maintenance Instructions (Cont)

NOTE

- Tag and mark all wires before disconnecting or removing.
 - Cut plastic cable ties as necessary.
- (2) Remove nine screws (5) and disconnect wires (6) from main terminal board (7).
- (3) Remove nut (8), adapter (9), and wires (6) from main junction box (4).

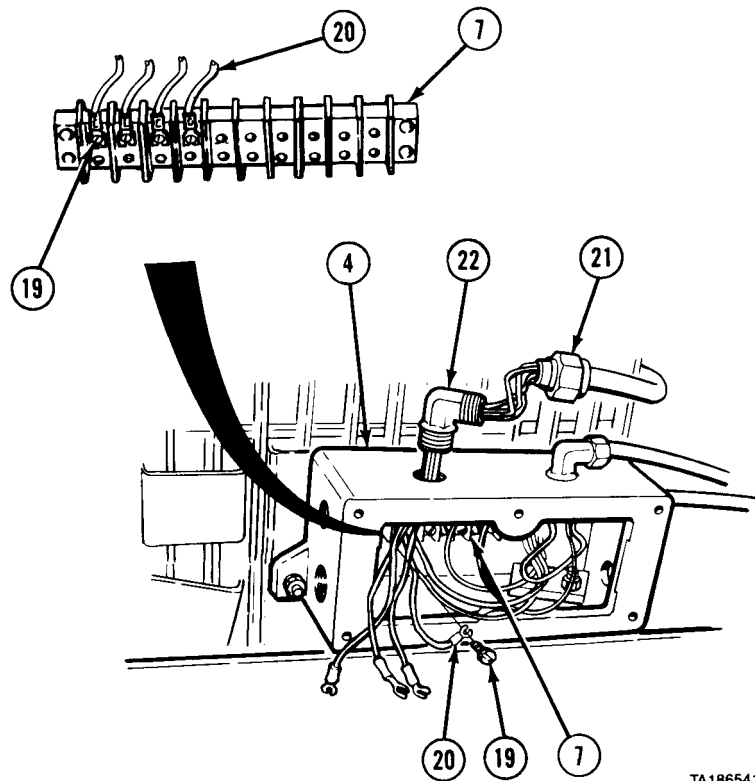


- (4) Remove nut (10), lockwasher (11), and two wires (12 and 13) from terminal board (14).
- (5) Remove two nuts (15 and 16), adapters (17 and 18), and wires (12 and 13) from main junction box (4).

Electrical System Maintenance Instructions (Cont)

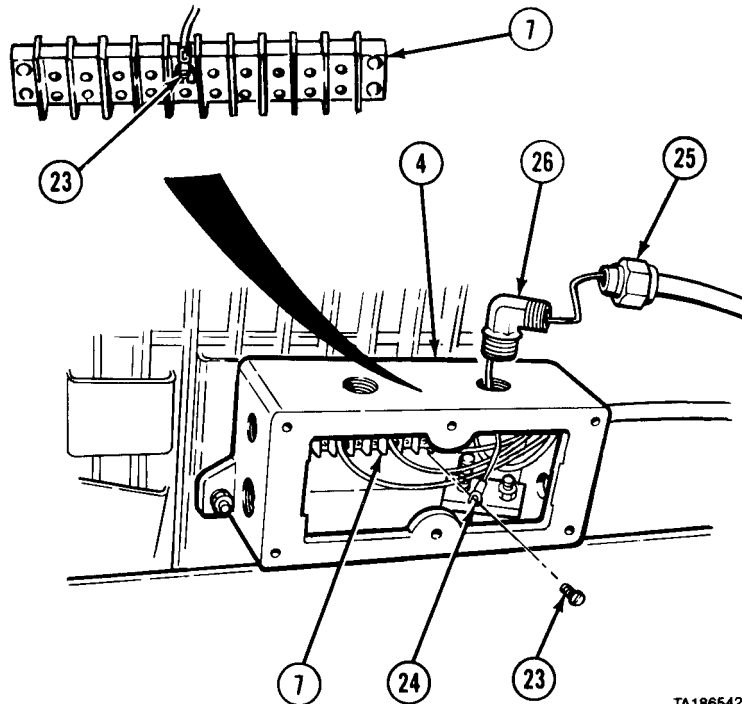
7-47. MAIN JUNCTION BOX ASSEMBLY REMOVAL/INSTALLATION (CONT).

- (6) Remove four screws (19) and wires (20) from main terminal board (7).
- (7) Remove nut (21), elbow (22), and four wires (20) from main junction box (4).



TA186541

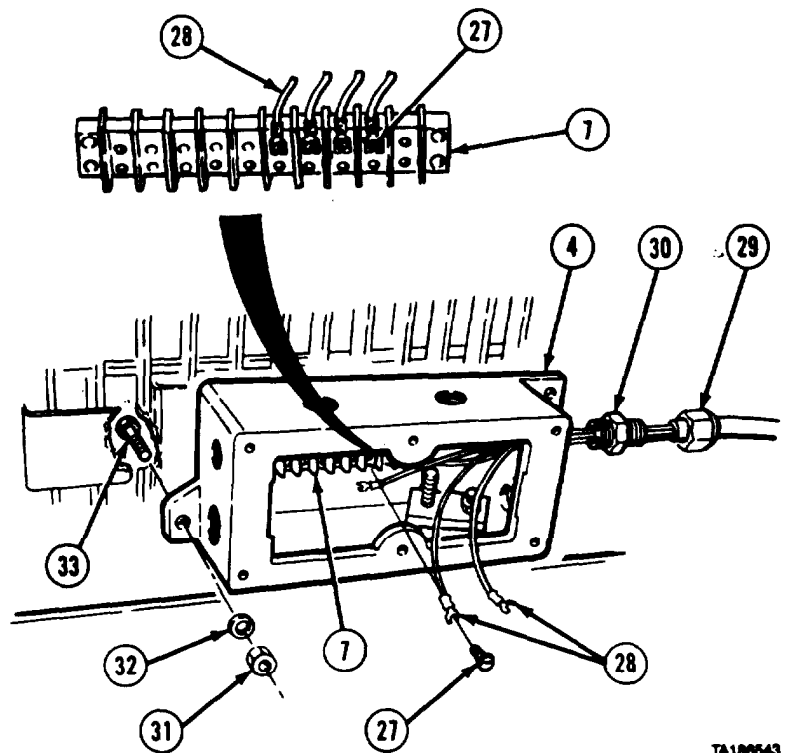
- (8) Remove screw (23) and wire (24) from main terminal board (7).
- (9) Remove nut (25), elbow (26) and wire (24) from main junction box (4).



TA186542

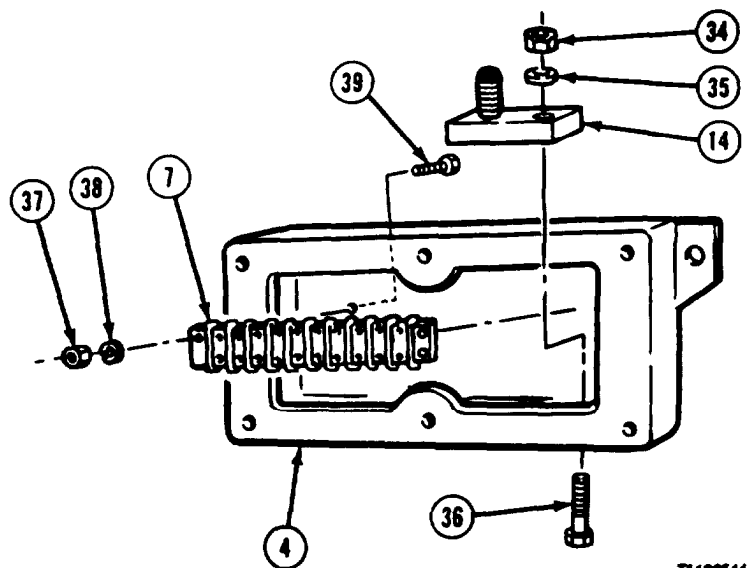
Electrical System Maintenance Instructions (Cont)

- (10) Remove four screws (27) and disconnect wires (28) from main terminal board (7).
- (11) Remove nut (29), adapter (30), and wires (28) from main junction box (4).
- (12) Remove two nuts (31), lockwashers (32), screws (33), and main junction box (4) from pump module.



TA100543

- (13) Remove nut (34), lockwasher (35), terminal board (14), and screw (36) from main junction box (4).
- (14) Remove two nuts (37), lockwashers (38), main terminal board (7), and two screws (39).



TA100544

Electrical System Maintenance Instructions (Cont)

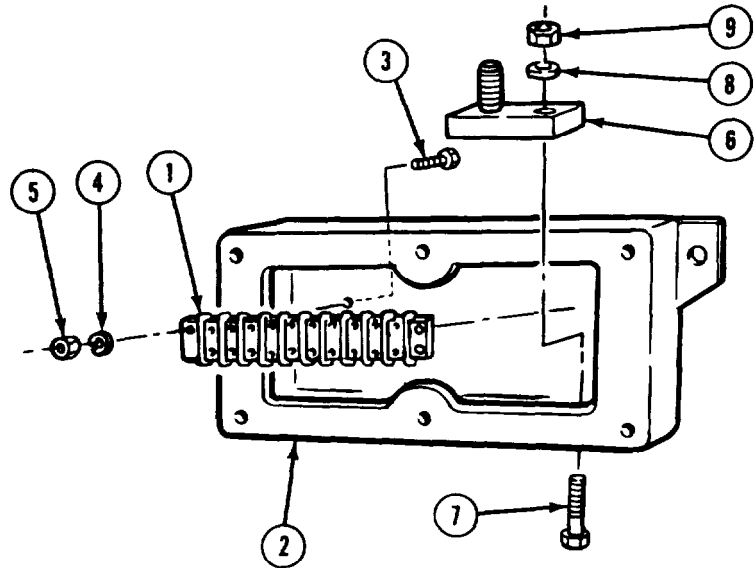
7-47. MAIN JUNCTION BOX ASSEMBLY REMOVAL/INSTALLATION (CONT).

b. Installation.

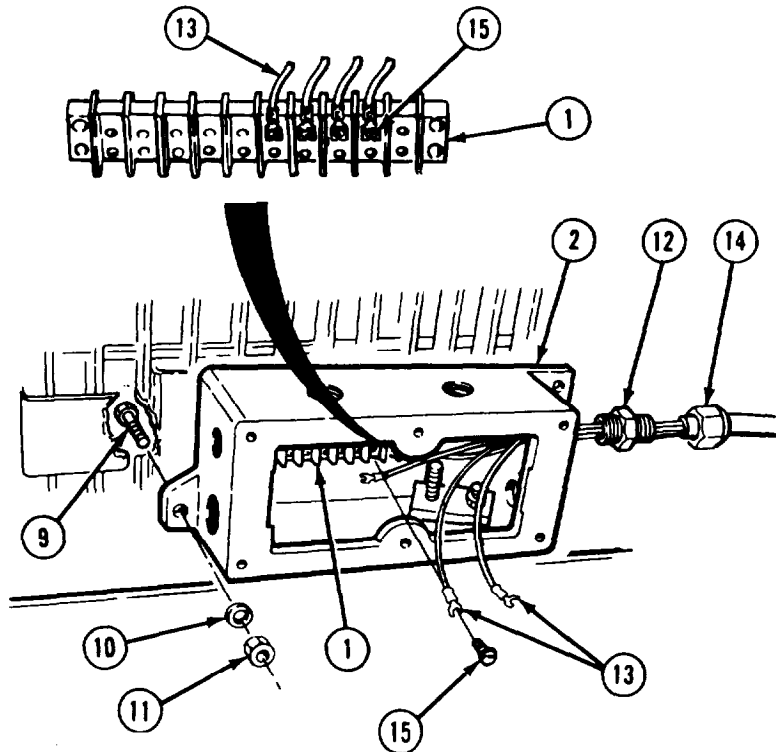
- (1) Install main terminal board (1) in main junction box (2) with two screws (3), lockwashers (4), and nuts (5).
- (2) Install terminal board (6) with screw (7), lockwashers (8), and nut (9).

WARNING

Adhesives, solvents, and sealing compounds can burn easily, can give off harmful vapors, and are harmful to skin and clothing. To avoid injury or death, keep away from open fire and use in well-ventilated area. If adhesive, solvent, or sealing compound gets on skin or clothing, wash immediately with soap and water.



- (3) Apply silicone adhesive-sealant over screw heads (3 and 7).
- (4) Install main junction box (2) on pump module with two screws (9), lockwashers (10), and nuts (11).
- (5) Apply sealing compound to threads of adapter (12).
- (6) Install four wires (13), adapter (12), and nut (14) in main junction box (2).
- (7) Install four wires (13) on terminal board (1) with four screws (15).

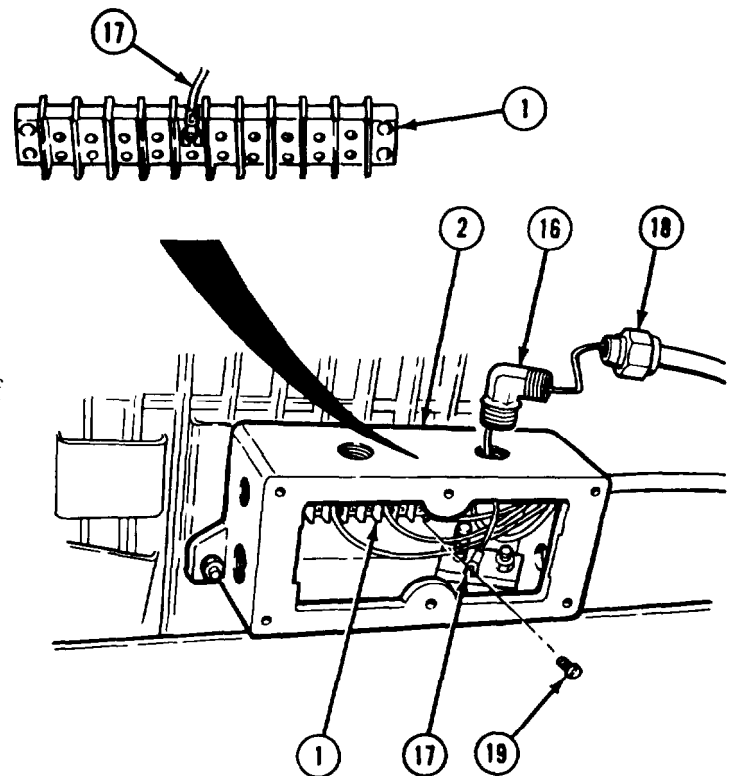


Electrical System Maintenance Instructions (Cont)

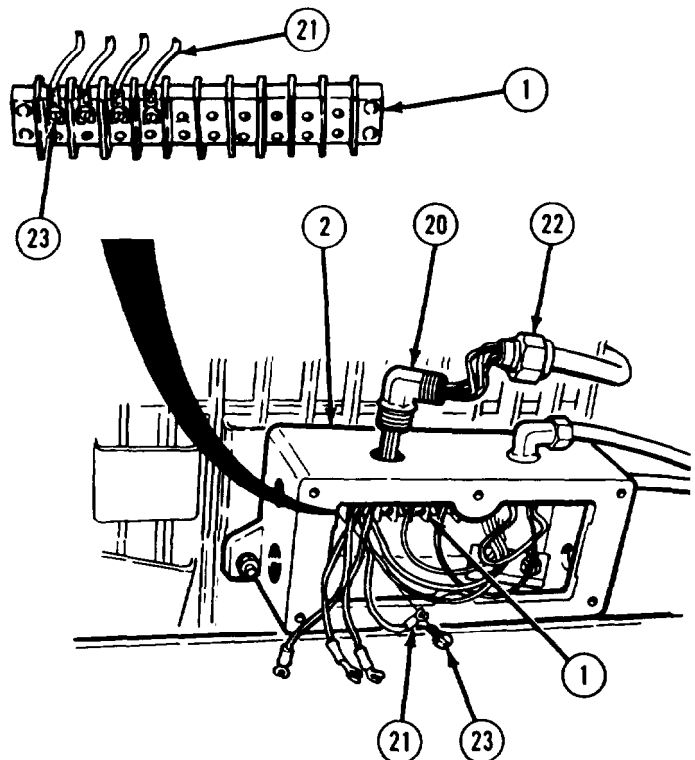
WARNING

Adhesives, solvents, and sealing compounds can burn easily, can give off harmful vapors, and are harmful to skin and clothing. To avoid injury or death, keep away from open fire and use in well-ventilated area. If adhesive, solvent, or sealing compound gets on skin or clothing, wash immediately with soap and water.

- (8) Apply sealing compound to threads of elbow (16).
- (9) Install elbow (16), wire (17), and nut (18) in main junction box (2).
- (10) Install wire (17) on main terminal board (1) with screw (19).



- (11) Apply sealing compound to threads of elbow (20).
- (12) Install elbow (20), four wires (21), and nut (22) in main junction box (2).
- (13) Install four wires (21) on main terminal board (1) with four screws (23).



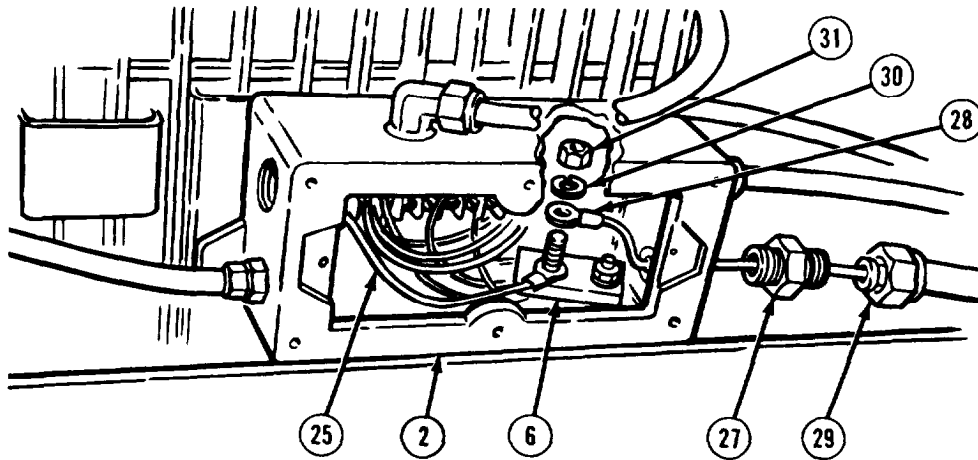
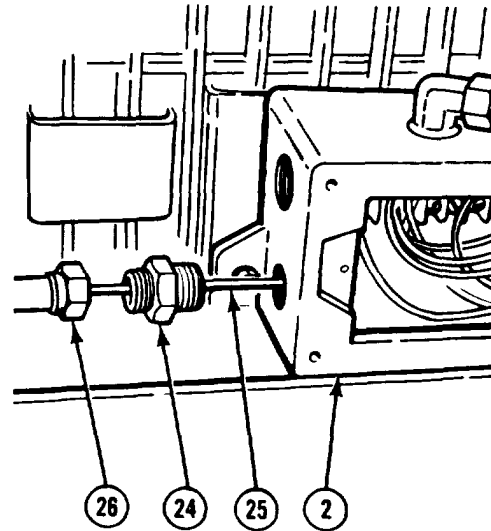
Electrical System Maintenance Instructions (Cont)

7-47. MAIN JUNCTION BOX ASSEMBLY REMOVAL/INSTALLATION (CONT).

WARNING

Adhesives, solvents, and sealing compounds can burn easily, can give off harmful vapors, and are harmful to skin and clothing. To avoid injury or death, keep away from open fire and use in well-ventilated area. If adhesive, solvent, or sealing compound gets on skin or clothing, wash immediately with soap and water.

- (14) Apply sealing compound to threads of adapter (24).
- (15) Install wire (25), adapter (24), and nut (26) in main junction box (2).



- (16) Apply sealing compound to threads of adapter (27).
- (17) Install wire (28), adapter (27), and nut (29) in main junction box (2).
- (18) Install two wires (25 and 28) on terminal board (6) with lockwasher (30) and nut (31).

Electrical System Maintenance Instructions (Cont)

WARNING

Adhesives, solvents, and sealing compounds can burn easily, can give off harmful vapors, and are harmful to skin and clothing. To avoid injury or death, keep away from open fire and use in well-ventilated area. If adhesive, solvent, or sealing compound gets on skin or clothing, wash immediately with soap and water.

NOTE

Replace plastic ties as necessary.

- (19) Apply sealing compound to threads of adapter (32) and install adapter.
- (20) Install nine wires (33) and nut (34) in main junction box (2).
- (21) Install nine wires (33) on main terminal board (1) with nine screws (35).

- (22) Apply silicone adhesive-sealant to both sides of gasket (36).
- (23) Install cover (37) and gasket (36) on main junction box (2) with six screws (38).

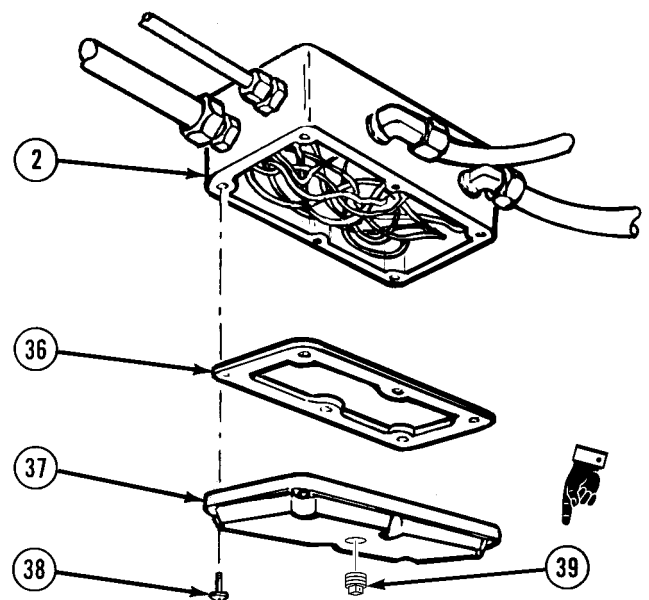
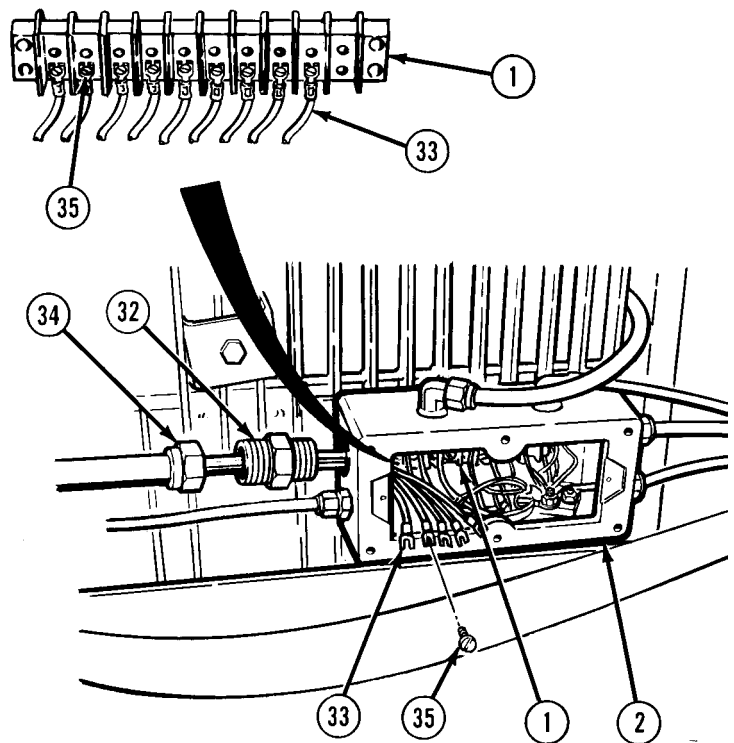
NOTE

Some covers have a plug. Do step (24) for these covers.

- (24) Apply sealing compound to threads of plug (39) and install plug in cover (37).

c. **Follow-on Maintenance.**

- (1) Connect batteries (para 7-91).
- (2) Check that TANK LEVEL INDICATOR and compartment and marker lights work (TM 9-2320-279-10).
- (3) Check tanker operation (TM 9-2320-279-10).



END OF TASK

Electrical System Maintenance Instructions (Cont)

7-48. AUXILIARY PUMP JUNCTION BOX ASSEMBLY REMOVAL/INSTALLATION (M978).

This task covers:

- a. Removal
- b. Installation
- c. Follow-on Maintenance

INITIAL SETUP

Models
M978

Test Equipment
None

Special Tools
None

Supplies
Compound, sealing, pipe thread, Item 18, Appendix C
Tags, identification, Item 48, Appendix C

Personnel Required
MOS 63S, Heavy wheel vehicle mechanic

References
None

Equipment Condition

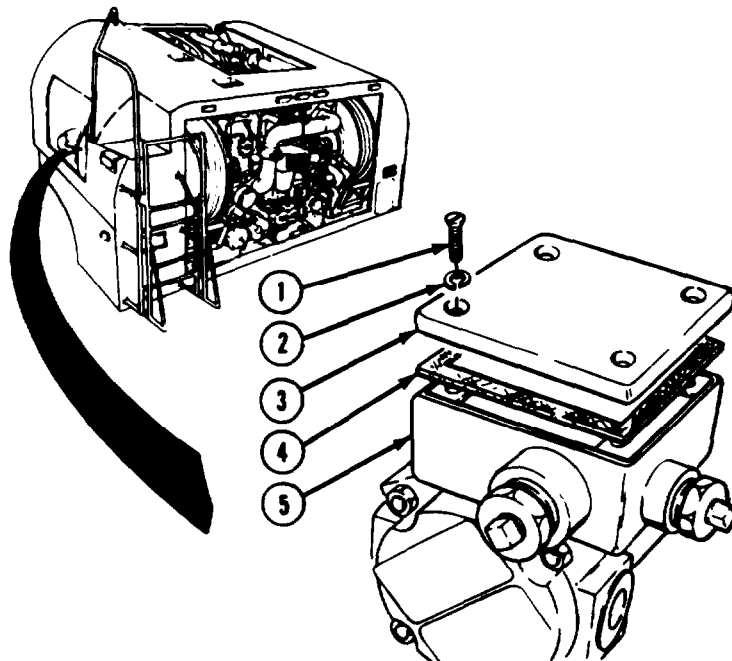
| | | |
|------------|-------------|---------------------------------|
| TM or Para | condition | Description |
| Para 7-91 | Batteries | disconnected. |
| Para 16-48 | Pump module | left side access panel removed. |

Special Environmental Conditions
None

General Safety Instructions
No smoking, flame, sparks, and hot or glowing objects within 50 ft (15 m) of vehicle.

a. Removal.

- (2) Remove four screws (1), lockwashers (2), cover (3), and gasket (4) from junction box (5).

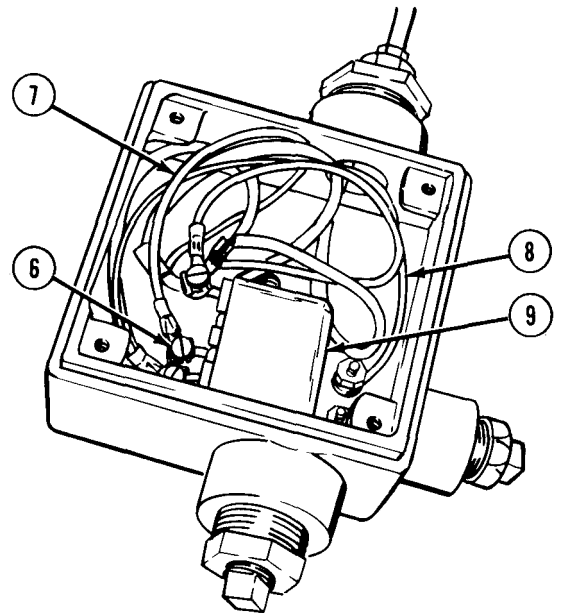


TA100863

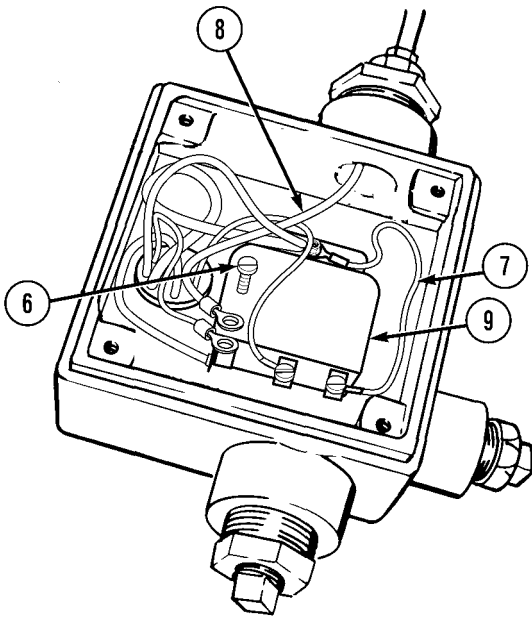
Electrical System Maintenance Instructions (Cont)

NOTE

- Tag and mark all wires before disconnecting or removing.
 - There are two model configurations when working on auxiliary pump system. Model A does not incorporate a ground strap. Model B incorporates a ground strap from auxiliary pump junction box to auxiliary pump.
- (2) Remove four screws (6) and disconnect six wires (7 and 8) from relay (9).



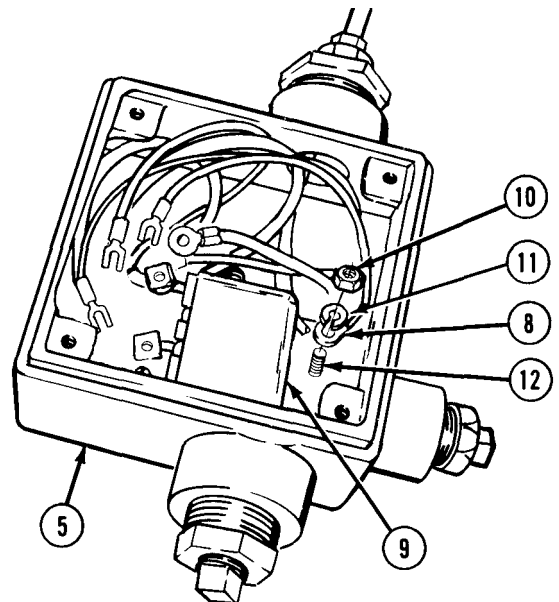
MODEL A



MODEL B

NOTE

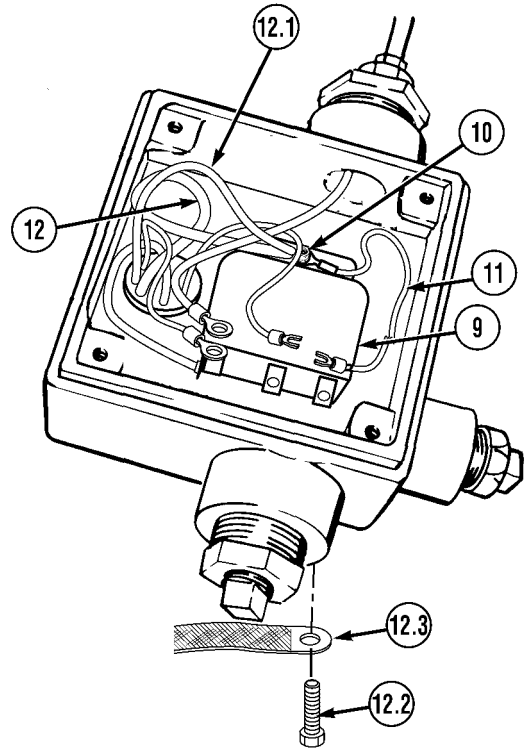
- Perform step (3) if working on Model A.
 - Perform step (3.1) if working on Model B.
- (3) Remove two nuts (10), lockwashers (11), wire (8), relay (9), and two screws (12) from junction box (5).



MODEL A

Electrical System Maintenance Instructions (Cont)

- (3.1) Remove nut (10), wire (11), wire (12), wire (12.1) relay (9), screw (12.2), and ground strap (12.3) from junction box (5).

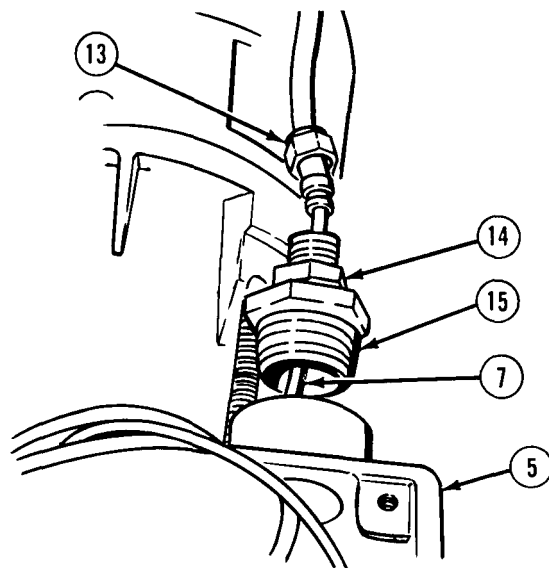


MODEL B

Electrical System Maintenance Instructions (Cont)

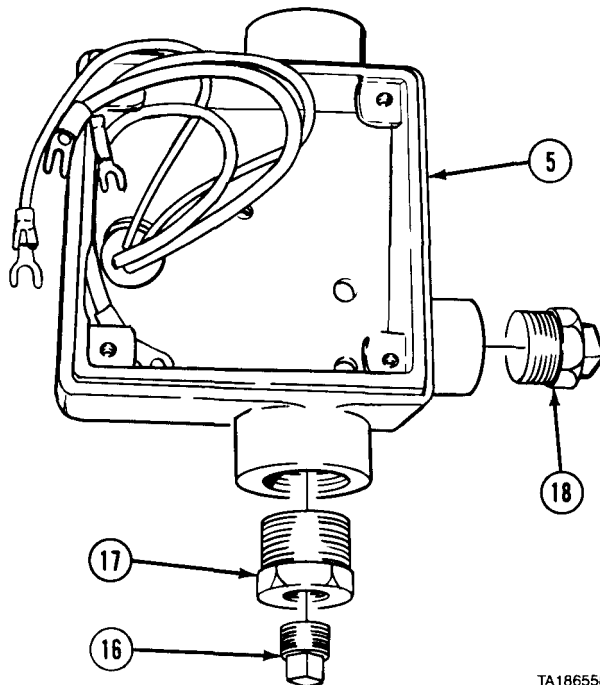
7-48. AUXILIARY PUMP JUNCTION BOX ASSEMBLY REMOVAL/INSTALLATION (M978)
(CONT).

(4) Remove nut (13), adapter (14), adapter (15),
and wire (7) from junction box (5).



TA186557

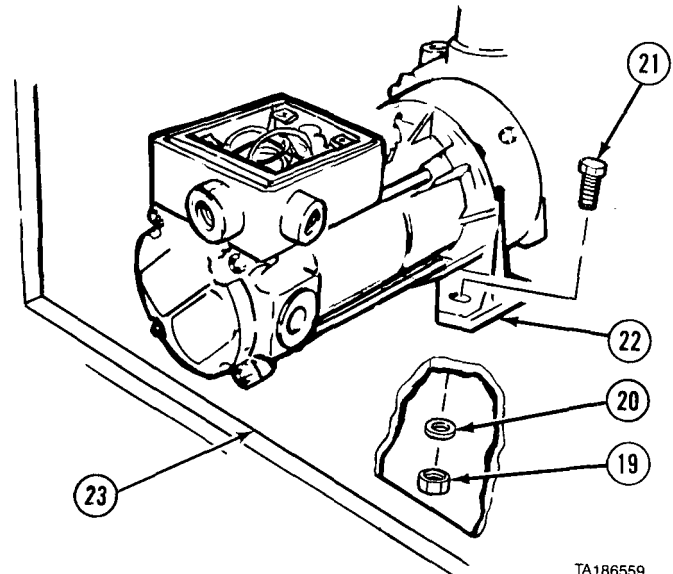
(5) Remove plug (16) and adapter (17).
(6) Remove plug (18) from junction box (5).



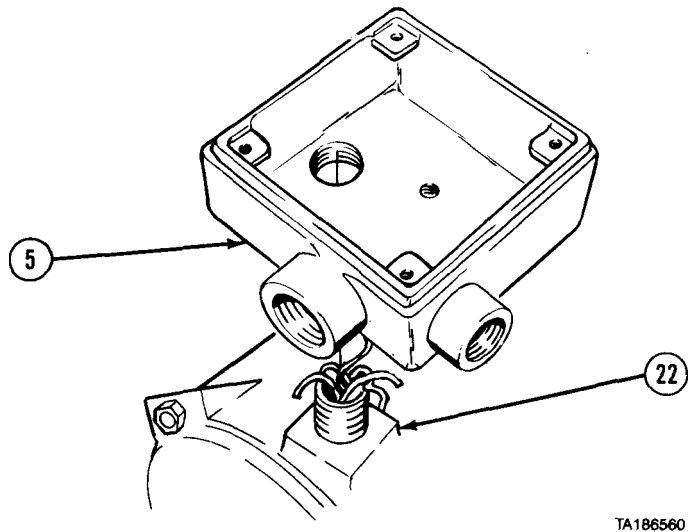
TA186558

Electrical System Maintenance Instructions (Cont)

- (7) Remove four locknuts (19), four washers (20), and four screws (21) from AUXILIARY PUMP (22) and wheel well (23).
- (8) Move AUXILIARY PUMP (22) down for clearance.



- (9) Remove junction box (5) from AUXILIARY PUMP (22).

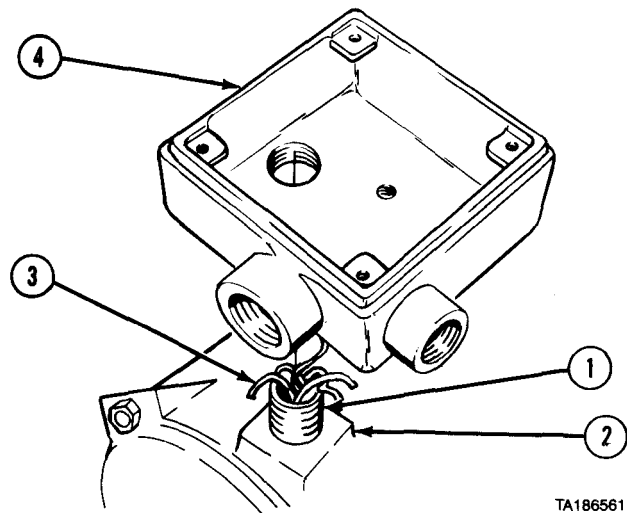


b. Installation.

WARNING

Adhesives, solvents, and sealing compounds can burn easily, can give off harmful vapors, and are harmful to skin and clothing. To avoid injury or death, keep away from open fire and use in well-ventilated area. If adhesive, solvent, or sealing compound gets on skin or clothing, wash immediately with soap and water.

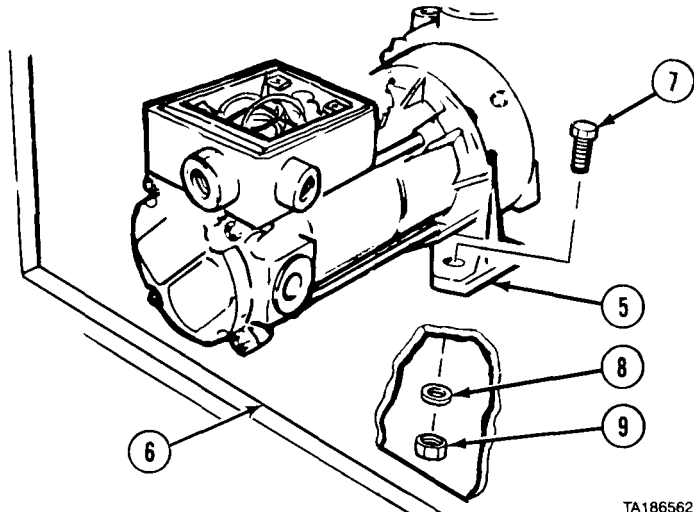
- (1) Apply pipe thread sealing compound to threads of pipe nipple (1) on AUXILIARY PUMP (2).
- (2) Thread wires (3) in junction box (4), and install junction box on pipe nipple (1).



Electrical System Maintenance Instructions (Cont)

7-48. AUXILIARY PUMP JUNCTION BOX ASSEMBLY REMOVAL/INSTALLATION (M978)
(CONT).

- (3) Position pump (5) on wheel well (6).
- (4) Install pump (5) with four screws (7), washers (8), and nuts (9).

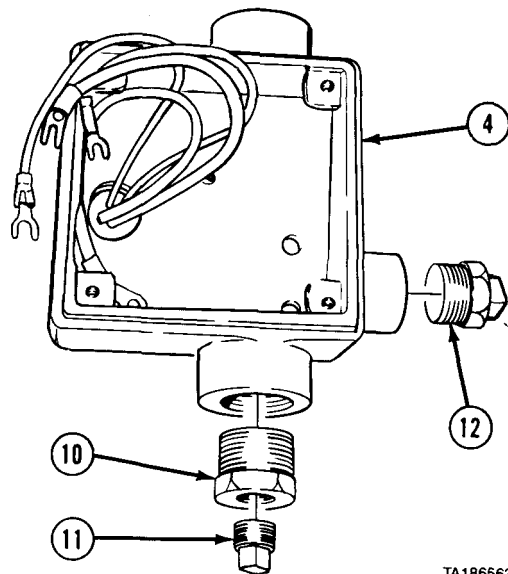


TA186562

W A R N I N G

Adhesives, solvents, and sealing compounds can burn easily, can give off harmful vapors, and are harmful to skin and clothing. To avoid injury or death, keep away from open fire and use in well-ventilated area. If adhesive, solvent, or sealing compound gets on skin or clothing, wash immediately with soap and water.

- (5) Apply pipe thread sealing compound to threads of adapter (10) and two plugs (11 and 12).
- (6) Install adapter (10) and two plugs (11 and 12) in junction box (4).



TA186563

Electrical System Maintenance Instructions (Cont)

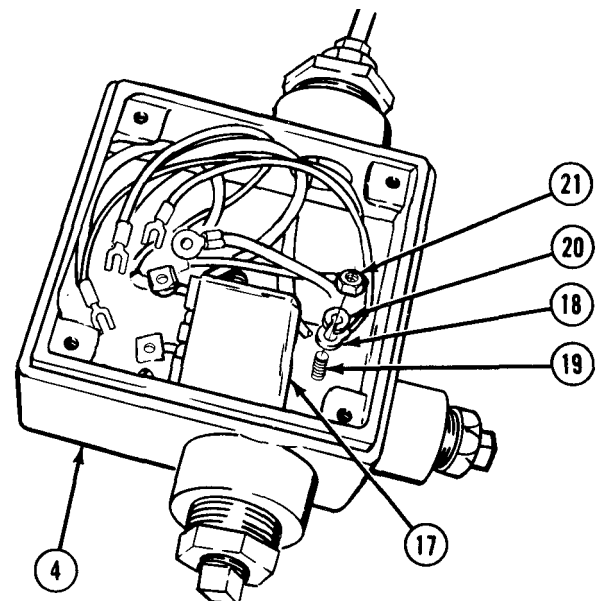
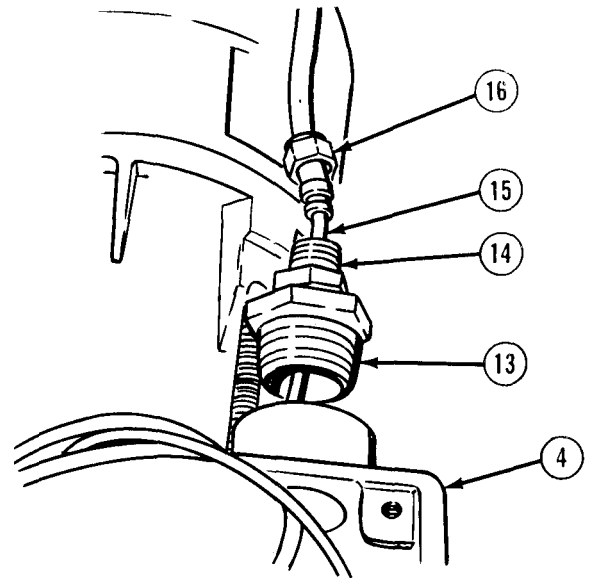
WARNING

Adhesives, solvents, and sealing compounds can burn easily, can give off harmful vapors, and are harmful to skin and clothing. To avoid injury or death, keep away from open fire and use in well-ventilated area. If adhesive, solvent, or sealing compound gets on skin or clothing, wash immediately with soap and water.

- (7) Apply pipe thread sealing compound to threads of two adapters (13 and 14).
- (8) Thread wire (15) in junction box (4) and install adapter (13), adapter (14), and nut (16).

NOTE

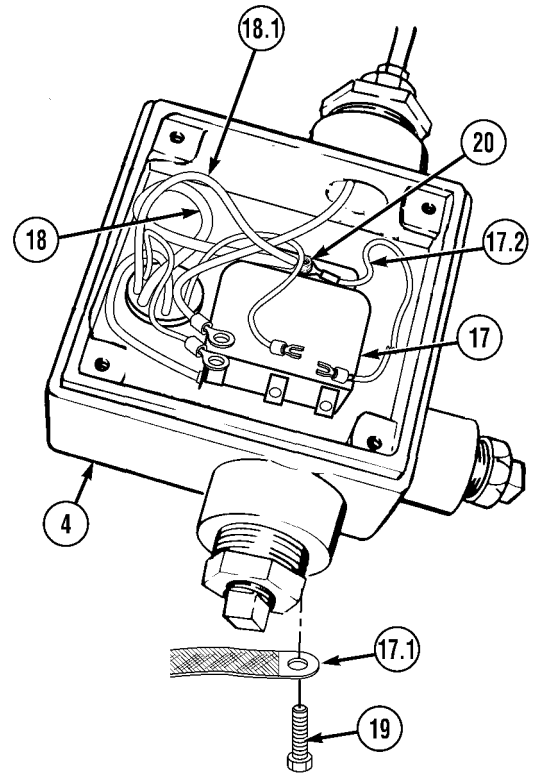
- There are two model configurations when working on auxiliary pump system. Model A does not incorporate a ground strap. Model B incorporates a ground strap from auxiliary pump junction box to auxiliary pump.
 - Perform step (9) if working on Model A.
 - Perform step (9.1) if working on Model B.
- (9) Install relay (17) and wire (18) in junction box (4) with two screws (19), lockwashers (20), and nuts (21).



MODEL A

Electrical System Maintenance Instructions (Cont)

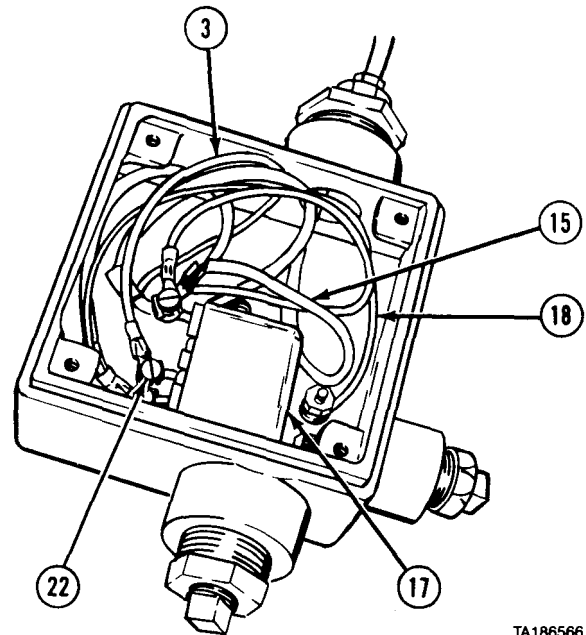
- (9.1) Install relay (17), ground strap (17.1), wire (17.2), wire (18), and wire (18.1) in junction box (4) with screw (19), and nut (20).

**MODEL B**

Electrical System Maintenance Instructions (Cont)

7-48. AUXILIARY PUMP JUNCTION BOX ASSEMBLY REMOVAL/INSTALLATION (M978) (CONT).

- (10) Connect four wires (3), wire (15), and wire (18) on relay (17) with four screws (22).

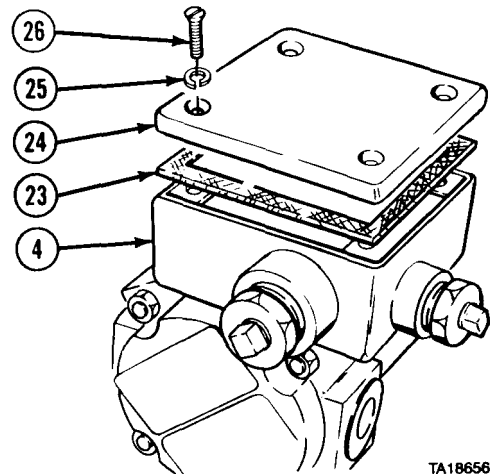


TA186566

- (11) Install gasket (23) and cover (24) on junction box (4) with four lockwashers (25) and screws (26).

c. Follow-on Maintenance.

- (1) Install pump module left side access panel (para 16-48).
- (2) Connect batteries (para 7-91).
- (3) Recirculate fuel using AUXILIARY PUMP (TM 9-2320-279-10).



TA186567

END OF TASK

Electrical System Maintenance Instructions (Cont)

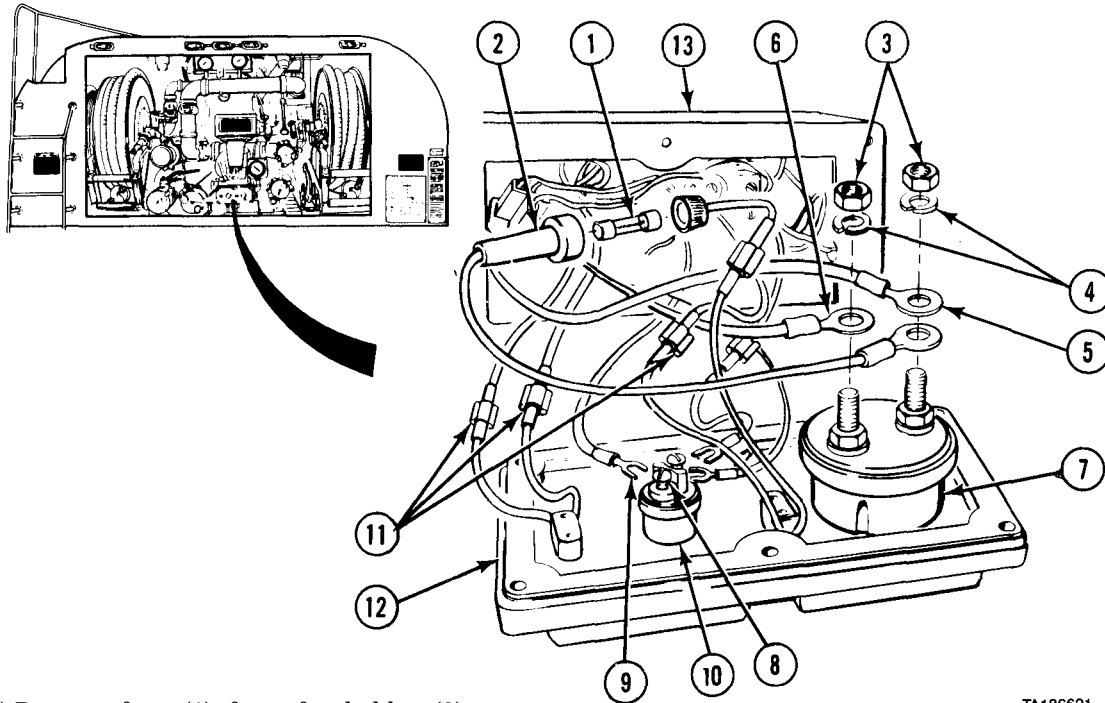
| | | |
|---|---|--|
| 7-49. CONTROL JUNCTION BOX REMOVAL/INSTALLATION (M978). | | |
| This task covers: | | |
| a. Removal | c. Follow-on Maintenance | |
| b. Installation | | |
| INITIAL SETUP | | |
| <i>Models</i> | <i>References</i> | |
| M978 | None | |
| <i>Test Equipment</i> | <i>Equipment Condition</i> | |
| None | <i>TM or Para</i> | <i>Condition Description</i> |
| <i>Special Tools</i> | Para 7-91 | Batteries disconnected. |
| None | Para 7-87 | TLI TANK LEVEL INDICATOR removed. |
| <i>Supplies</i> | Para 23-35 | SP SAMPLING PROBE valve bracket removed. |
| Ties, cable, plastic, Item 52, Appendix C | <i>Special Environmental Conditions</i> | |
| Adhesive-sealant, silicone, Item 4, Appendix C | None | |
| Compound, sealing, pipe thread, Item 18, Appendix C | <i>General Safety Instructions</i> | |
| <i>Personnel Required</i> | No smoking, flame, sparks, and hot or glowing objects within 50 ft (15 m) of vehicle. | |
| MOS 63S, Heavy wheel vehicle mechanic | | |



Electrical System Maintenance Instructions (Cont)

7-49. CONTROL JUNCTION BOX REMOVAL/INSTALLATION (M978) (CONT).

a. Removal.



(1) Remove fuse (1) from fuseholder (2).

TA186621

NOTE

- Tag and mark wires before disconnecting or removing.
- Remove plastic cable ties as necessary.

(2) Remove two nuts (3), lockwashers (4), fuseholder (2), and two wires (5 and 6) from rotary switch (7).

(3) Remove two screws (8) and three wires (9) from contact button (10).

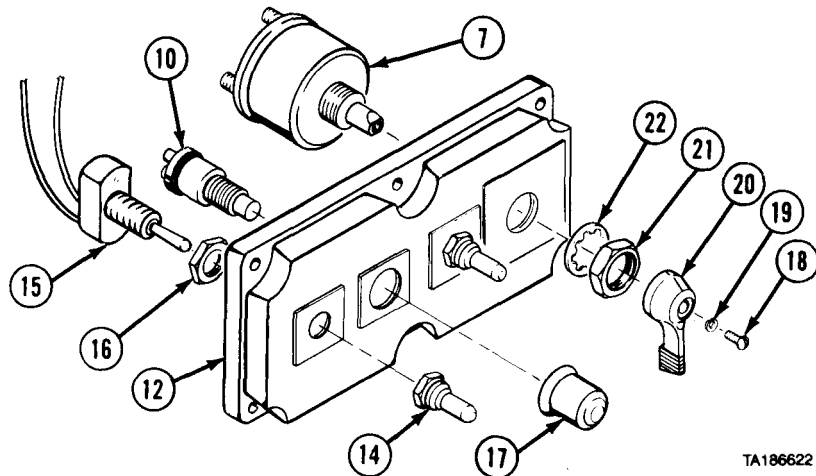
(4) Disconnect three connectors (11) and remove cover (12) from control junction box (13).

Matchmark position of contact button and switches.

(5) Remove two boots (14) from toggle switches (15) and remove switches from cover (12). Remove two nuts (16) from switches.

(6) Remove contact button cover (17) and contact button (10) from cover (12).

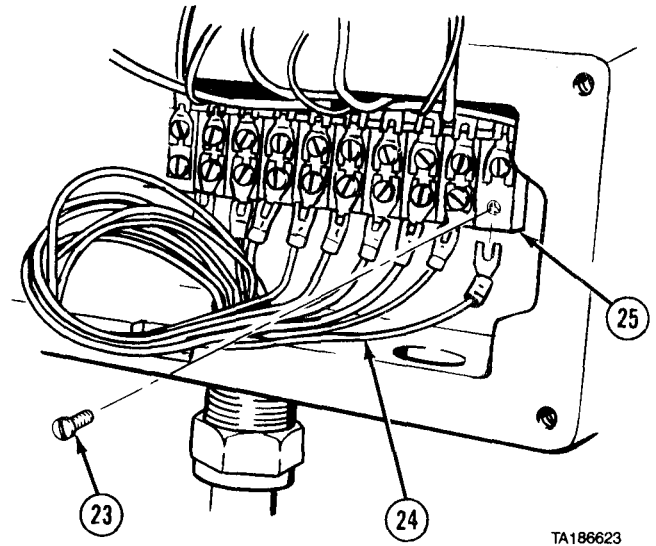
(7) Remove screw (18), lockwasher (19), knob (20), nut (21), and lockwasher (22) from rotary switch (7) and remove switch from cover (12).



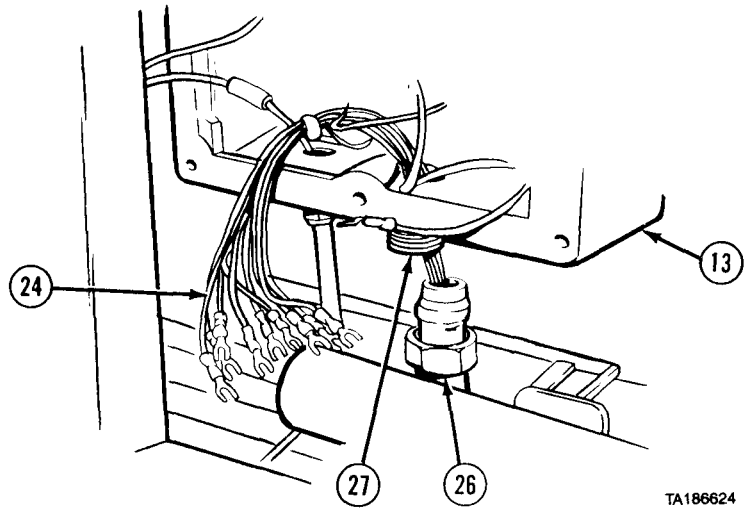
TA186622

Electrical System Maintenance Instructions (Cont)

- (8) Remove ten screws (23) and nine wires (24) from bottom of terminal board (25).



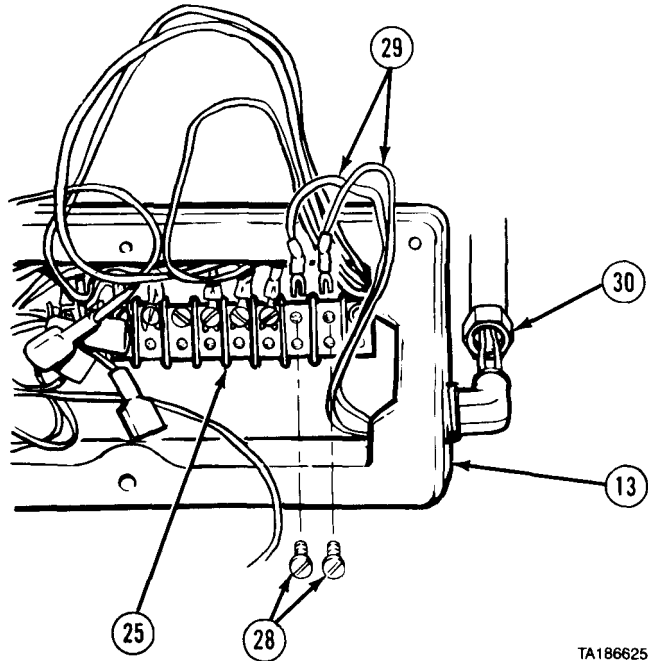
- (9) Remove nut (26) from adapter (27) and wires (24) from control junction box (13).



Electrical System Maintenance Instructions (Cont)

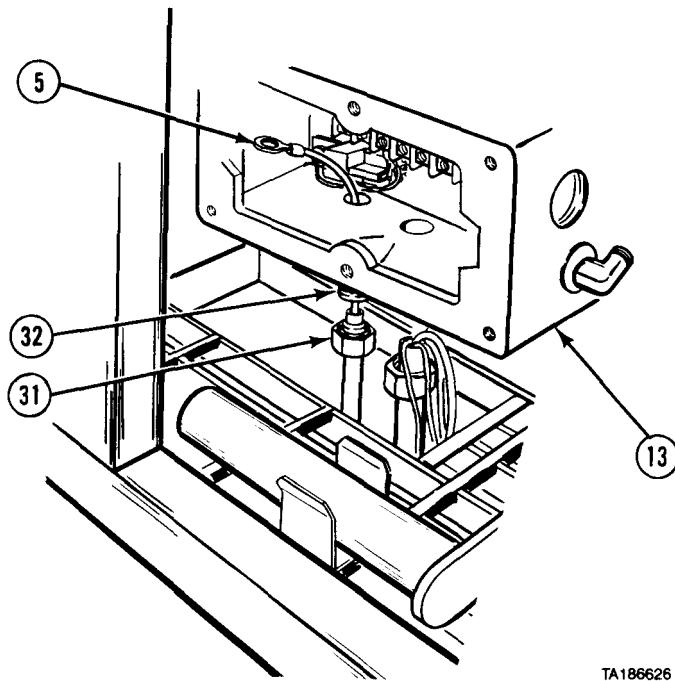
7-49. CONTROL JUNCTION BOX REMOVAL/INSTALLATION (M978) (CONT).

- (10) Remove two screws (28) and wires (29) from top of terminal board (25).
- (11) Remove nut (30) and two wires (29) from control junction box (13).



TA186625

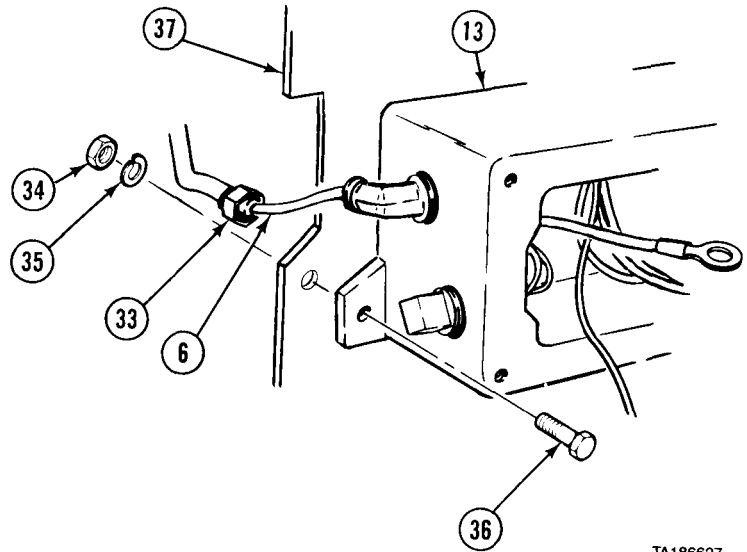
- (12) Remove nut (31) from adapter (32) and wire (5) from control junction box (13).



TA186626

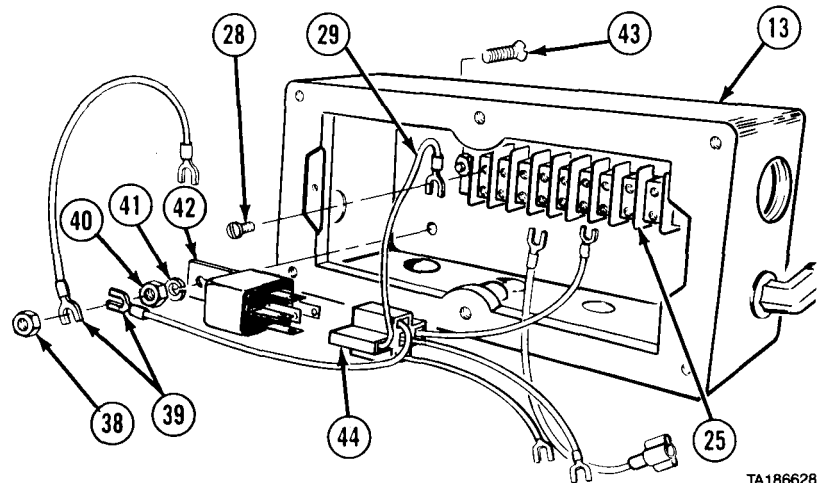
Electrical System Maintenance Instructions (Cont)

- (13) Remove nut (33) and wire (6) from control junction box (13).
- (14) Remove two nuts (34), lockwashers (35), screws (36), and control junction box (13) from bracket (37).



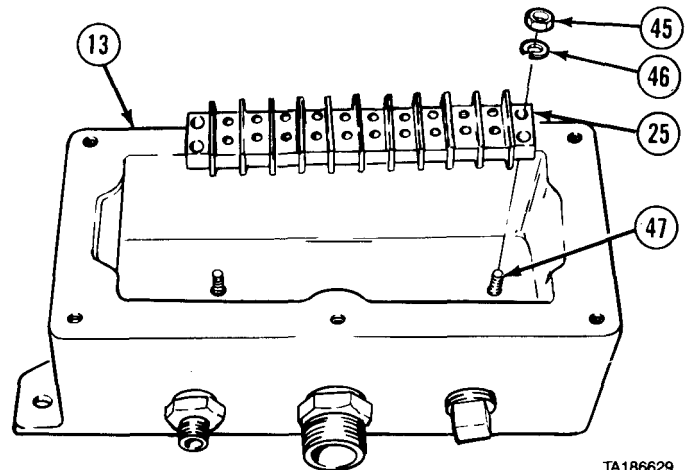
TA186627

- (15) Remove nut (38), two wires (39), nut (40), lockwasher (41), relay assembly (42), and screw (43) from junction box (13).
- (16) Remove connector (44) from relay assembly (42).
- (17) Remove five screws (28) and seven wires (29) from top of terminal board (25).



TA186628

- (18) Remove two nuts (45), lockwashers (46), terminal board (25), and two screws (47) from control junction box (13).



TA186629

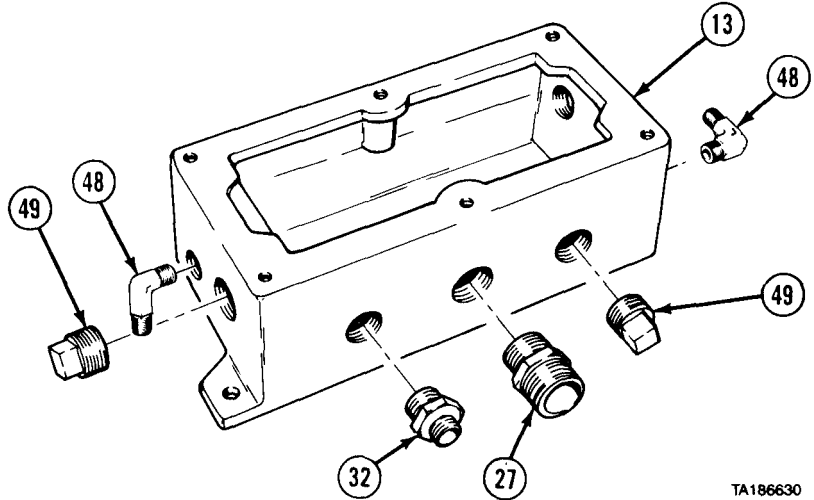
Electrical System Maintenance Instructions (Cont)

7-49. CONTROL JUNCTION BOX REMOVAL/INSTALLATION (M978) (CONT).

NOTE

Matchmark elbows.

- (19) Remove two elbows (48) from control junction box (13).
- (20) Remove two plugs (49) and adapters (32 and 27).

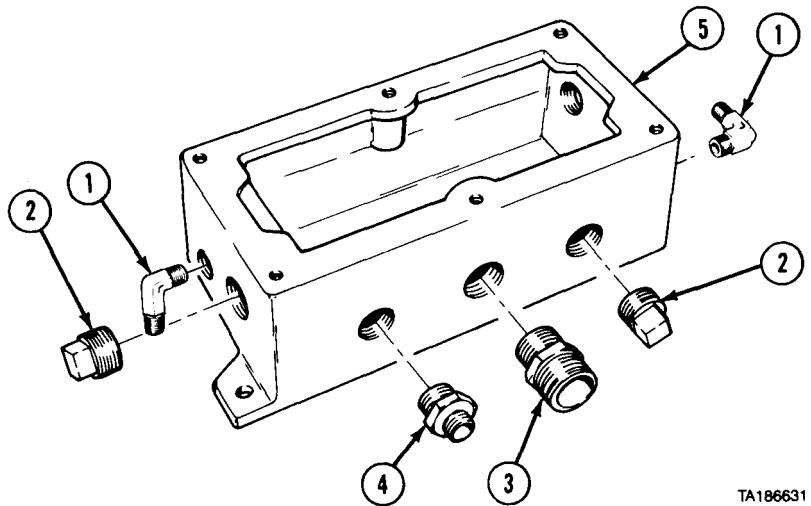


b. Installation.

WARNING

Adhesives, solvents, and sealing compounds can burn easily, can give off harmful vapors, and are harmful to skin and clothing. To avoid injury or death, keep away from open fire and use in well-ventilated area. If adhesive, solvent, or sealing compound gets on skin or clothing, wash immediately with soap and water.

- (1) Apply pipe thread sealing compound to threads of two elbows (1), plugs (2), and adapters (3 and 4).
- (2) Install two elbows (1), plugs (2), and adapters (3 and 4) in control junction box (5).

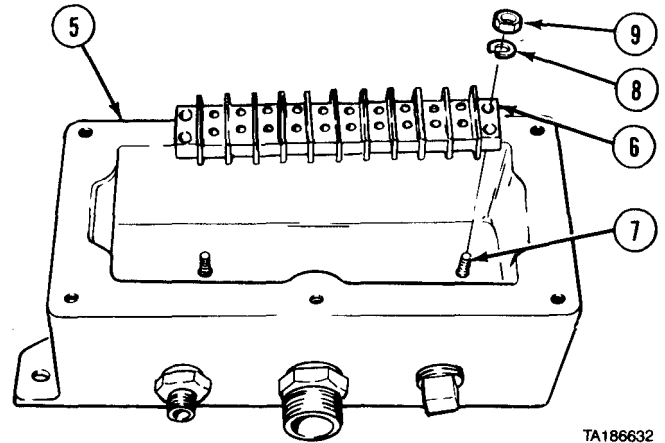


Electrical System Maintenance Instructions (Cont)

- (3) Install terminal board (6) in control junction box (5) with two screws (7), lockwashers (8), and nuts (9).

WARNING

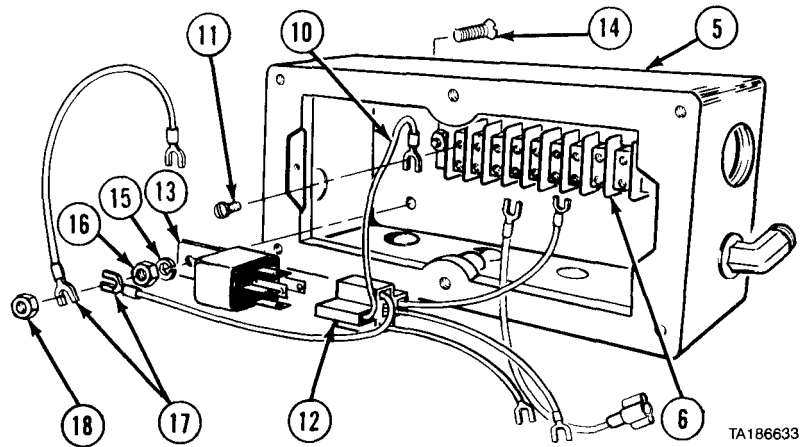
Adhesives, solvents, and sealing compounds can burn easily, can give off harmful vapors, and are harmful to skin and clothing. To avoid injury or death, keep away from open fire and use in well-ventilated area. If adhesive, solvent, or sealing compound gets on skin or clothing, wash immediately with soap and water.



TA186632

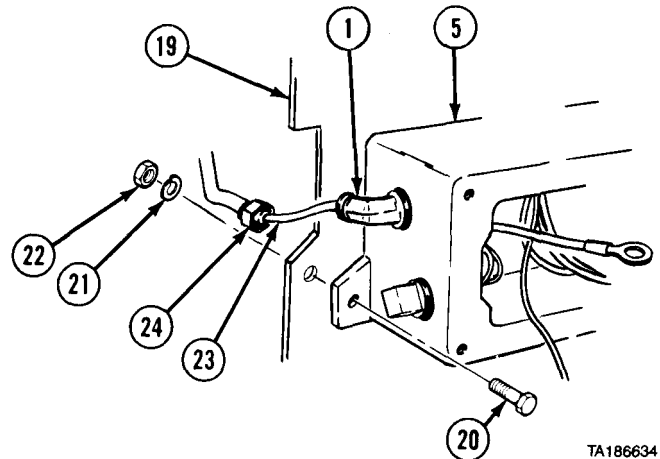
- (4) Apply silicone adhesive-sealant over screw heads (7).

- (5) Install seven wires (10) on terminal board (6) with five screws (11).
- (6) Install connector (12) on relay assembly (13).
- (7) Install screw (14), relay assembly (13), lockwasher (15), nut (16), two wires (17), and nut (18) in control junction box (5).
- (8) Apply silicone adhesive-sealant over screw head (14).



TA186633

- (9) Position control junction box (5) on bracket (19) and install two screws (20), lockwashers (21), and nuts (22).
- (10) Position wire (23) in control junction box (5) and install nut (24) on elbow (1).

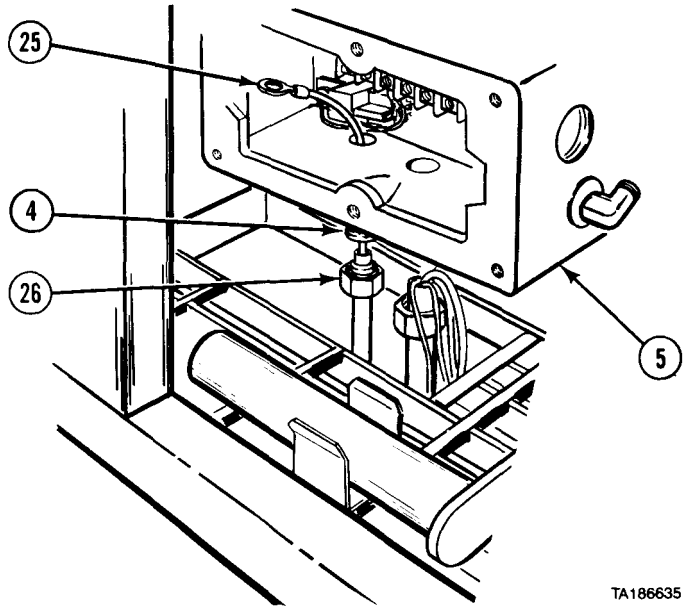


TA186634

Electrical System Maintenance Instructions (Cont)

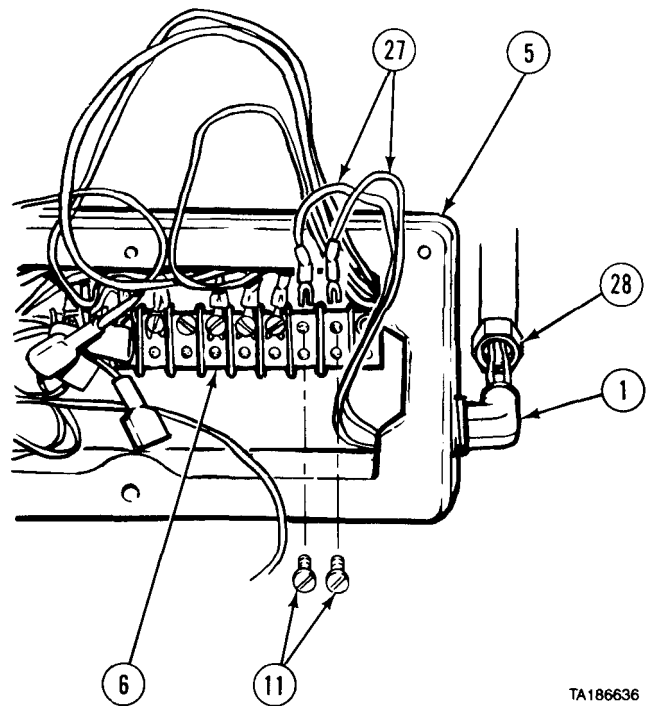
7-49. CONTROL JUNCTION BOX REMOVAL/INSTALLATION (M978) (CONT).

(11) Position wire (25) in control junction box (5) and install nut (26) on adapter (4).



TA186635

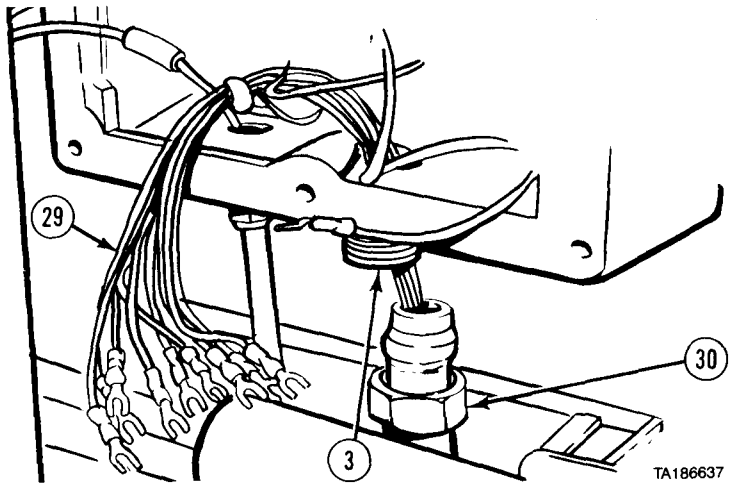
(12) Position two wires (27) in control junction box (5) and install nut (28) on elbow (1).
 (13) Install two wires (27) on terminal board (6) with two screws (11).



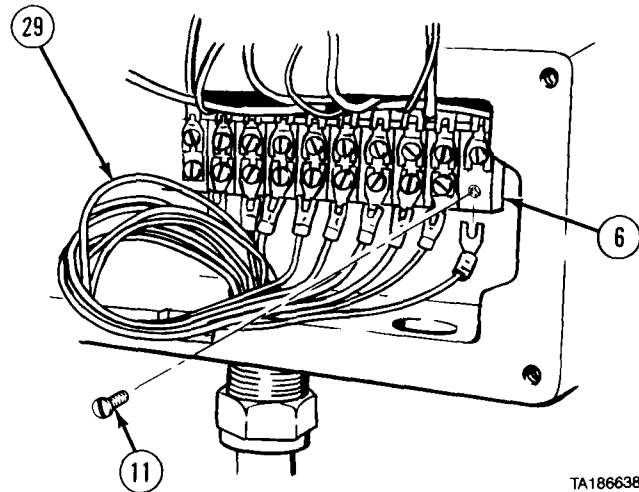
TA186636

Electrical System Maintenance Instructions (Cont)

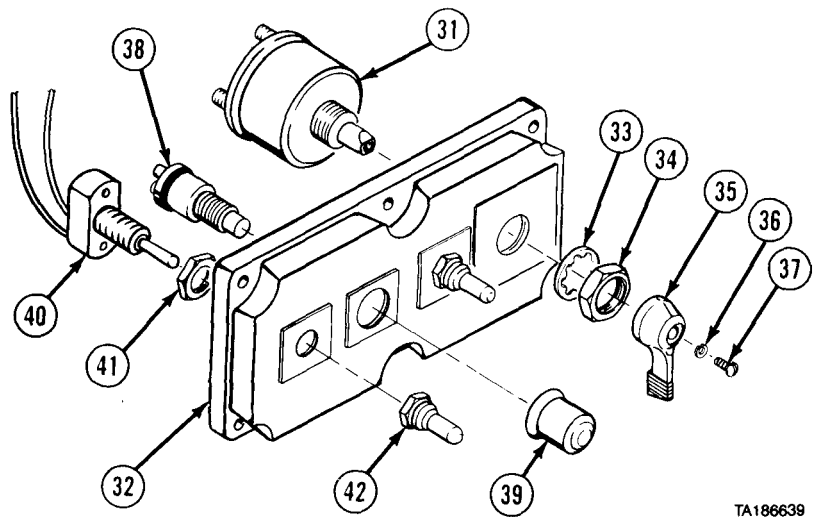
- (14) Position nine wires (29) through adapter (3) and install nut (30) on adapter.



- (15) Install nine wires (29) on terminal board (6) with ten screws (11).



- (16) Install rotary switch (31) in control junction box cover (32) with lockwasher (33), nut (34), and install knob (35), lockwasher (36), and screw (37).
- (17) Install contact button (38) with contact button cover (39).
- (18) Install two toggle switches (40) with nuts (41) and boots (42).



Electrical System Maintenance Instructions (Cont)

7-49. CONTROL JUNCTION BOX REMOVAL/INSTALLATION (M978) (CONT).

- (19) Connect three connectors (43).
- (20) Install three wires (44) on contact button (38) with two screws (45).

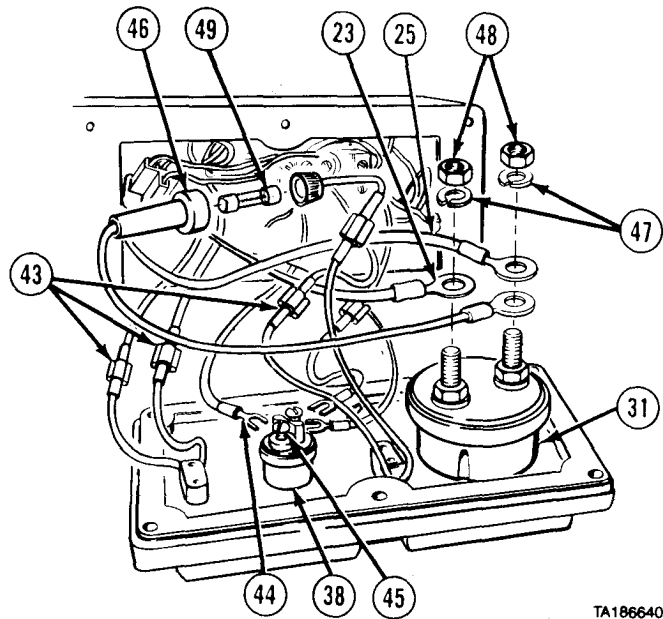
NOTE

Replace plastic cable ties as necessary.

- (21) Install two wires (23 and 25), fuseholder (46), two lockwashers (47), and nuts (48) on rotary switch (31).
- (22) Install fuse (49) in fuseholder (46) and connect.

c. Follow-on Maintenance.

- (1) Install TLI TANK LEVEL INDICATOR (para 7-87).
- (2) Install SP SAMPLING PROBE valve bracket (para 23-35).
- (3) Connect batteries (para 7-91).
- (4) Check operation of control functions (TM 9-2320-279-10).



TA186640

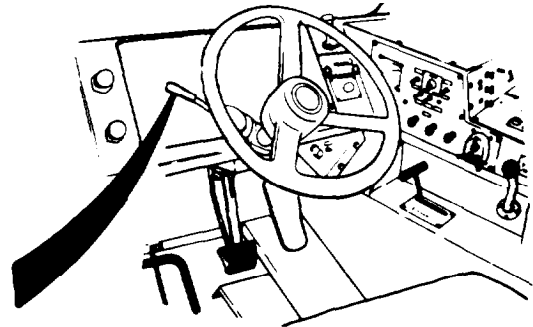
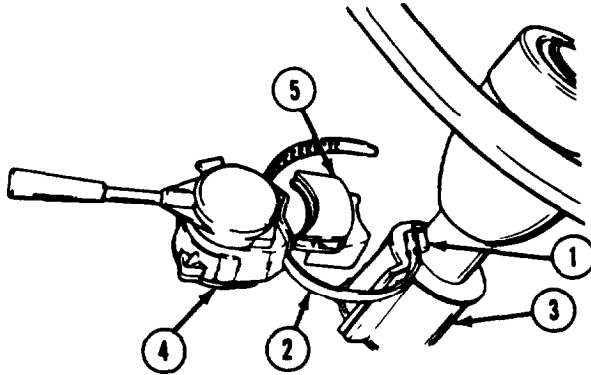
END OF TASK

Section VII. MISCELLANEOUS SWITCHES

| | | | | | |
|---|--|-------------------|------------------------------|-----------|---------------------------|
| 7-50. TURN SIGNAL SWITCH REMOVAL/INSTALLATION. | | | | | |
| This task covers: | | | | | |
| <ul style="list-style-type: none"> a. Removal b. Installation | <ul style="list-style-type: none"> c. Follow-on Maintenance | | | | |
| INITIAL SETUP | | | | | |
| <p><i>Models</i> All</p> <p><i>Test Equipment</i> None</p> <p><i>Special Tools</i> None</p> <p><i>Supplies</i> Connector, electrical, butt, Item 19, Appendix C Tags, identification, Item 48, Appendix C Ties, cable, plastic, Item 52, Appendix C</p> | <p><i>Personnel Required</i> MOS 63S, Heavy wheel vehicle mechanic</p> <p><i>References</i> None</p> <p><i>Equipment Condition</i></p> <table border="0"> <tr> <td><i>TM or Para</i></td> <td><i>Condition Description</i></td> </tr> <tr> <td>Para 7-19</td> <td>Instrument panel removed.</td> </tr> </table> <p><i>Special Environmental Conditions</i> None</p> <p><i>General Safety Instructions</i> None</p> | <i>TM or Para</i> | <i>Condition Description</i> | Para 7-19 | Instrument panel removed. |
| <i>TM or Para</i> | <i>Condition Description</i> | | | | |
| Para 7-19 | Instrument panel removed. | | | | |

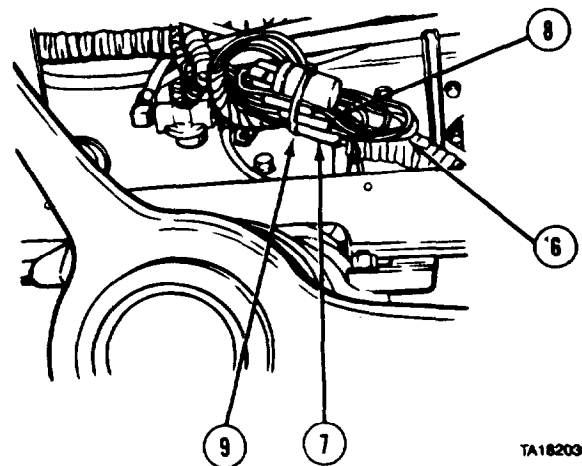
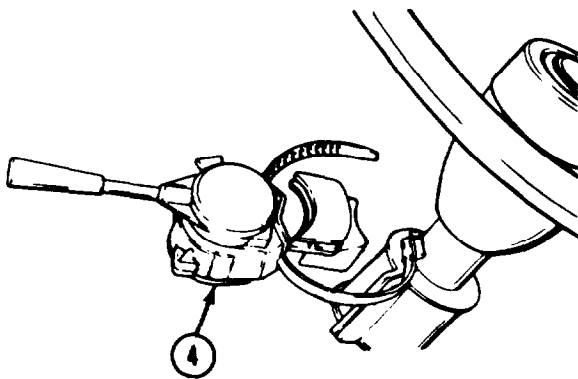
Electrical System Maintenance Instructions (Cont)

a. **Removal.**



TA182036

- (1) Loosen screw (1) and remove strap (2) from steering column (3).
- (2) Remove turn signal switch (4) and mounting base (5) from steering column (3).



TA182036

NOTE

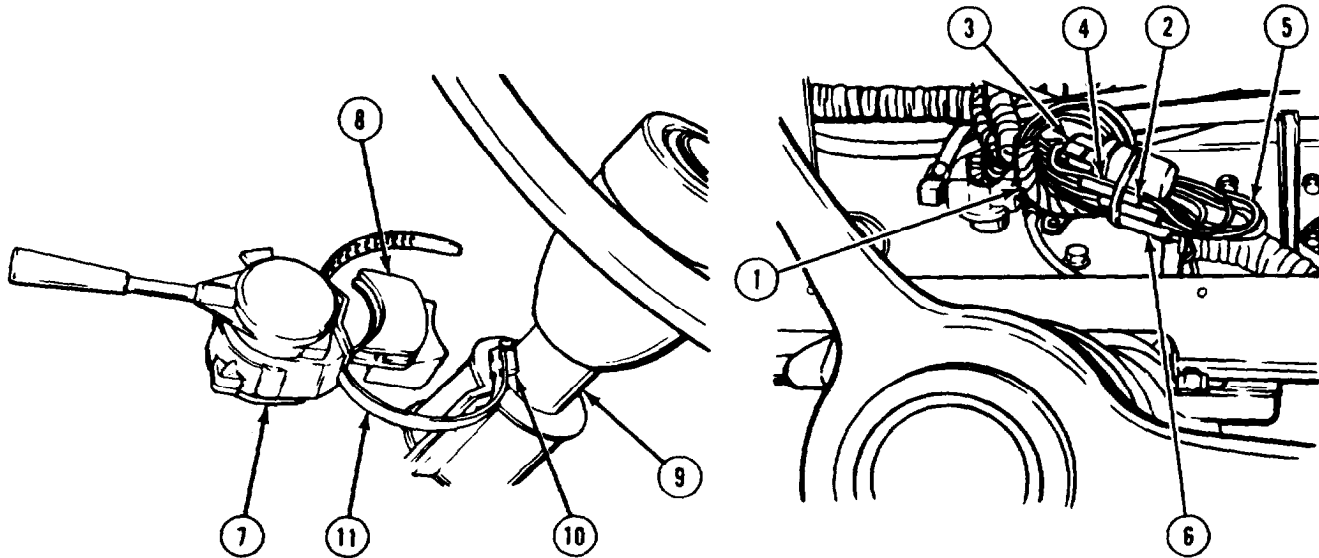
- Remove plastic cable ties as required.
- Tag and mark wires before removing or disconnecting.

- (3) Disconnect five wires (6) at inline connectors (7).
- (4) Cut flasher wire (8) to flasher socket wire (9).
- (5) Remove turn signal switch (4).

Electrical System Maintenance Instructions (Cont)

7-50. TURN SIGNAL SWITCH REMOVAL/INSTALLATION (CONT).

b. Installation.



NOTE

The turn signal switches on some models with brake override, are also supplied with a self-canceling ring, spring, and three mounting screws, packaged separately. The self-canceling feature is not used on the vehicle. Discard these items.

- (1) Install turn signal switch wire harness (1) under dash.
- (2) Connect flasher wire (2) to flasher socket wire (3) with electrical butt connector (4).
- (3) Connect five wires (5) to inline connectors (6).
- (4) Position turn signal switch (7) and mounting base (8) on steering column (9) and tighten screw (10) on strap (11).

c. Follow-on Maintenance.

- (1) Install instrument panel (para 7-19).
- (2) Check operation of turn signal switch (TM 9-2320-279-10).

END OF TASK

Electrical System Maintenance Instructions (Cont)

7-51. FLASHER RELAY REMOVAL/INSTALLATION.

This task covers:

- a. Removal
- b. Installation
- c. Follow-on Maintenance

INITIAL SETUP

Models

All

References

None

Test Equipment

None

Equipment Condition

| | |
|------------|-------------------------|
| TM or Para | Condition Description |
| Para 7-91 | Batteries disconnected. |

Special Tools

None

Special Environmental Conditions

None

Supplies

Ties, cable, plastic, Item 52, Appendix C
Compound, corrosion preventive, Item 12.1, Appendix C

General Safety Instructions

None

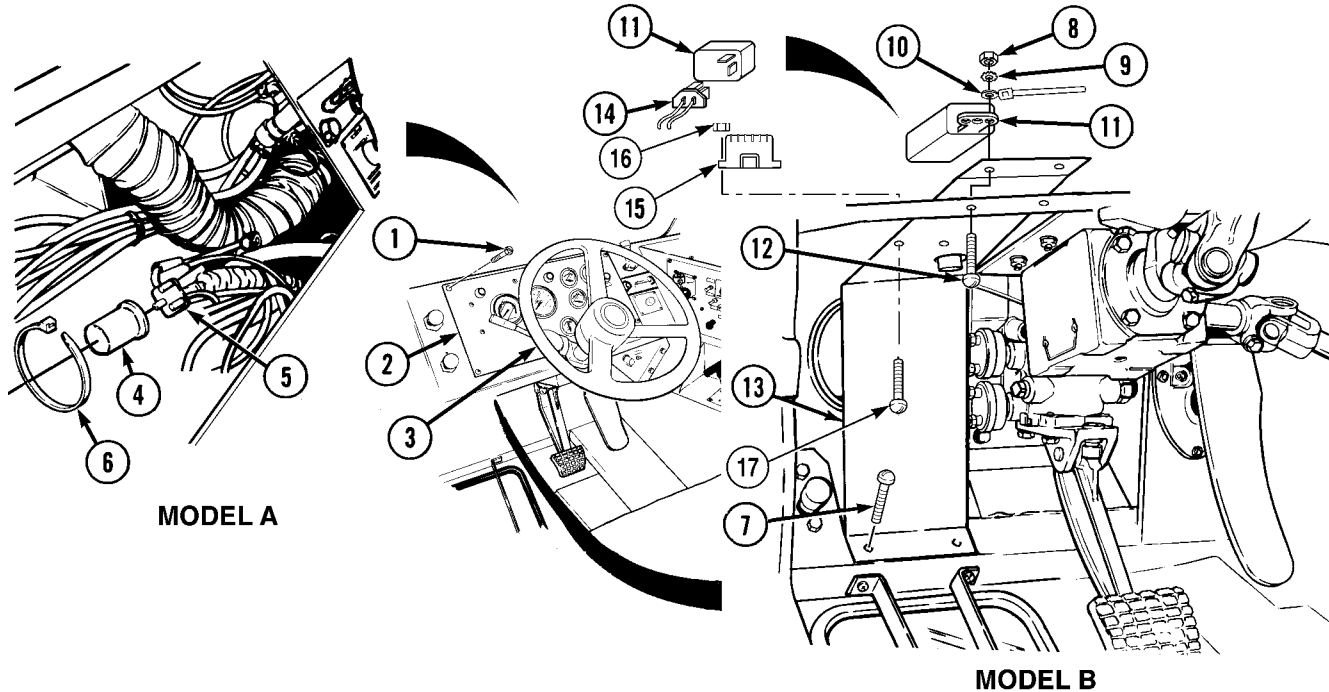
Personnel Required

MOS 63S, Heavy wheel vehicle mechanic

Electrical System Maintenance Instructions (Cont)

7-51. FLASHER RELAY REMOVAL/INSTALLATION (CONT).

a. Removal.

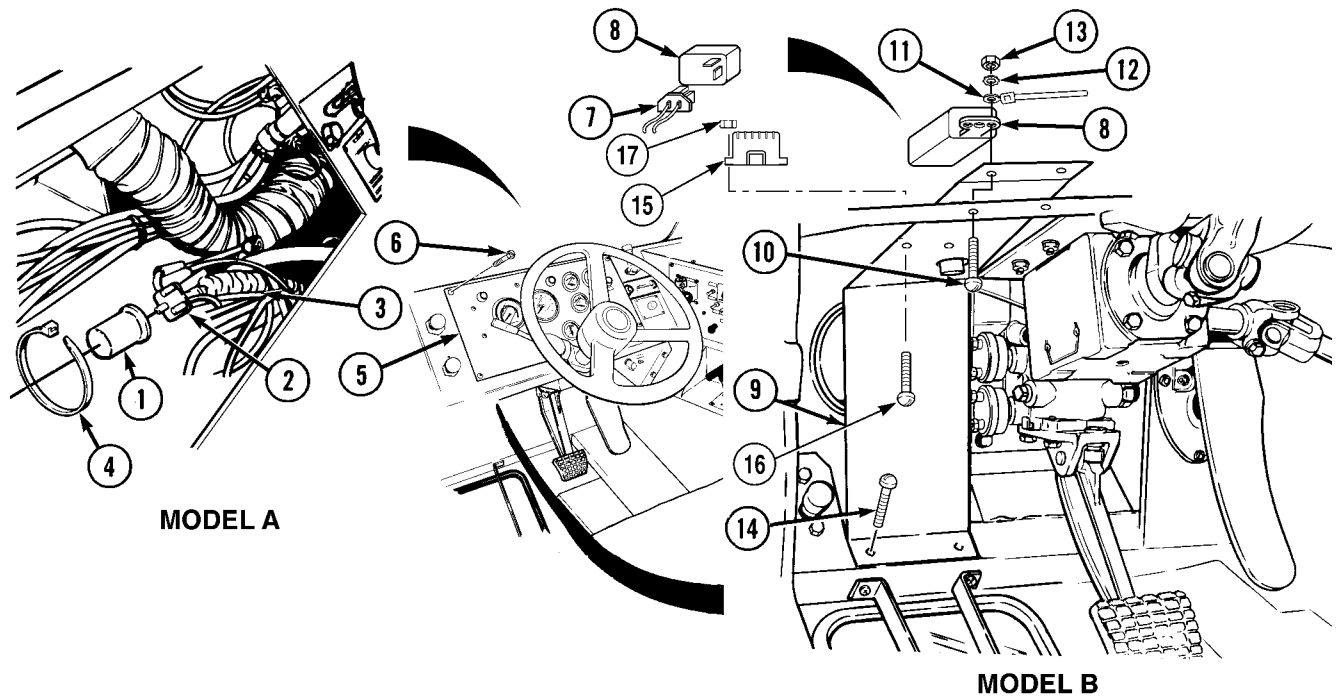


NOTE

- There are three kinds of flasher relays.
- Model A is round and is strapped to a wire harness with a plastic cable tie.
- Model B is square and is attached under the dash with a screw, lockwasher, and nut.
- Model C is attached to the headlight guard with two screws and locknuts.
- For Model A, do steps (1) through (4).
- For Model B, do steps (5) through (9).
- For Model C, do steps (10) and (11).

- (1) Remove six screws (1).
- (2) Move instrument panel (2) toward steering wheel (3).
- (3) Remove flasher relay (4) from base (5).
- (4) Cut plastic cable tie (6) and remove flasher relay (4).
- (5) Remove three screws (7).
- (6) Remove nut (8), lockwasher (9), ground wire (10), flasher relay (11), and screw (12).
- (7) Remove headlight guard (13).
- (8) Disconnect electrical connector (14) from flasher relay (11).
- (9) Remove flasher relay (11).
- (10) Remove electrical connector (14) from flasher relay (15).
- (11) Remove two locknuts (16), flasher relay (15), and two screws (17) from headlight guard (13).

Electrical System Maintenance instructions (Cont)

b. Installation.**NOTE**

- There are three kinds of flasher relays.
- Model A is round and is strapped to a wire harness with a plastic cable tie.
- Model B is square and is attached to the dash with a screw, lockwasher, and nut.
- Model C is attached to the headlight guard with two screws and locknuts.
- If a Model A relay must be replaced by a Model B relay, the top left side hole in the headlight guard must be drilled out and the self-tapping screw replaced by a screw, lockwasher, and nut. Also, a ground wire must be added. Route the ground wire along the wire harness to the ground point on the ignition switch bracket. Refer to TM 9-2320-279-24P for proper identification of parts.
- For Model A, do steps (1) through (3).
- For Model B, do steps (4) through (7).
- For Model C, do steps (8) and (9).

- (1) Install flasher relay (1) in base (2).
- (2) Secure flasher relay (1) to wire harness (3) with plastic cable tie (4).
- (3) Install instrument panel (5) with six screws (6).
- (4) Connect electrical connector (7) to flasher relay (8).
- (5) Position headlight guard (9) and relay (8) in appropriate area under driver-side dash panel.
- (6) Install screw (10), relay (8), ground wire (11), lockwasher (12), and nut (13).
- (7) Install three screws (14).
- (8) Install flasher relay (15) on headlight guard (9) with two screws (16) and locknuts (17).
- (9) Connect electrical connector (7) to flasher relay (15).

Electrical System Maintenance instructions (Cont)

7-51. FLASHER RELAY REMOVAL/INSTALLATION (CONT).

c. *Follow-on Maintenance.*

- (1) Connect batteries (para 7-91).
- (2) Check operation of turn signals (TM 9-2320-279-10).

END OF TASK

7-52. DELETED.

Electrical System Maintenance Instructions (Cont)

7-52.1 CONTROL BOX REMOVAL/REPAIR/INSTALLATION (M984E1).

This task covers:

- | | |
|--|--|
| a. Control Box Removal | g. Control Box Relays Removal |
| b. Control Box Installation | h. Control Box Relays Installation |
| c. Control Box Switches Removal | i. Control Box Junction Block Removal |
| d. Control Box Switches Installation | j. Control Box Junction Block Installation |
| e. Control Box Connectors Removal | k. Follow-on Maintenance |
| f. Control Box Connectors Installation | |

INITIAL SETUP

Models

M984E1

Test Equipment

None

Special Tools

None

Supplies

Tags, identification, Item 48, Appendix C
 Ties, plastic cable, Item 52, Appendix C
 Adhesive-Sealant, Item 4, Appendix C
 Treatment, Corrosion, Item 52.1, Appendix C

Personnel Required

MOS 63S, Heavy wheel vehicle mechanic

References

None

Equipment Condition

| | |
|-------------------|------------------------------|
| <i>TM or Para</i> | <i>Condition Description</i> |
| Para 7-91 | Batteries disconnected. |

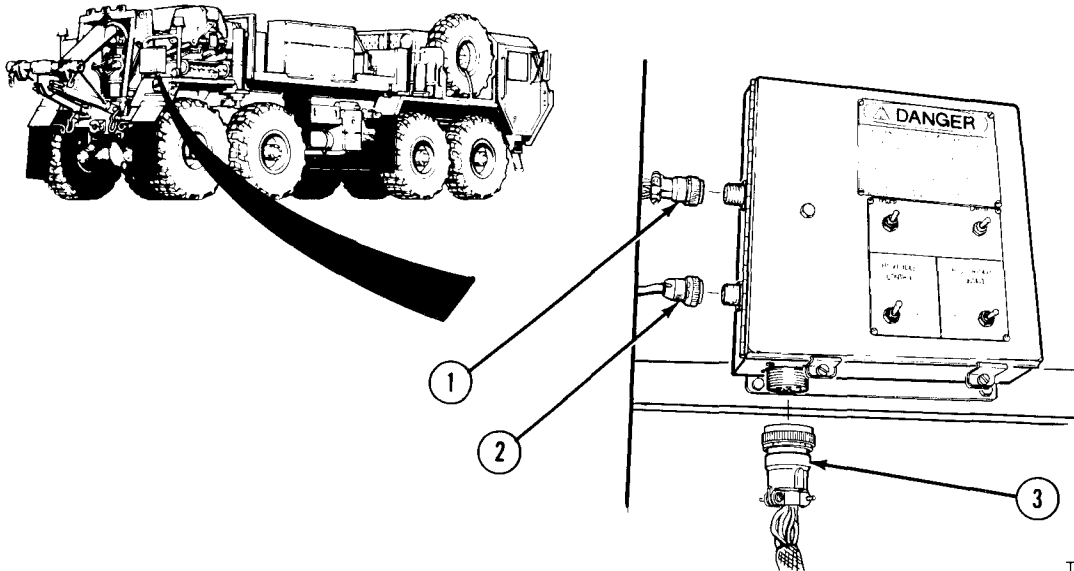
Special Environmental Conditions

None

General Safety Instructions

None

a. Control Box Removal.



TA475885

(1) Disconnect three connectors (1, 2, and 3).

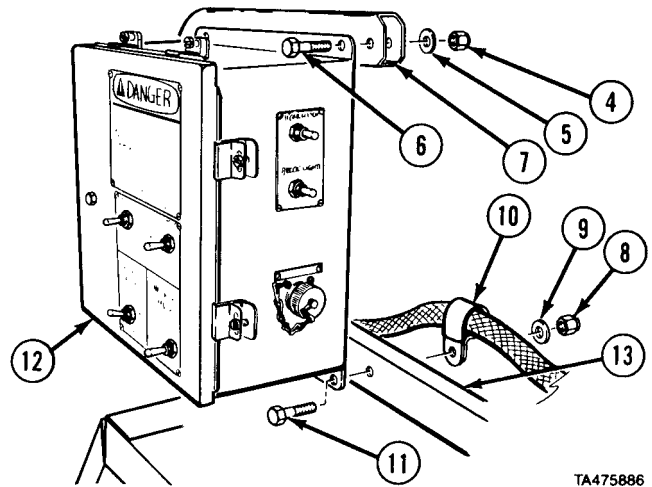
Electrical System Maintenance Instructions (Cont)

7-52.1. CONTROL BOX REMOVAL/REPAIR/INSTALLATION (M984E1) (CONT).

NOTE

Clips and plastic cable ties are removed as necessary.

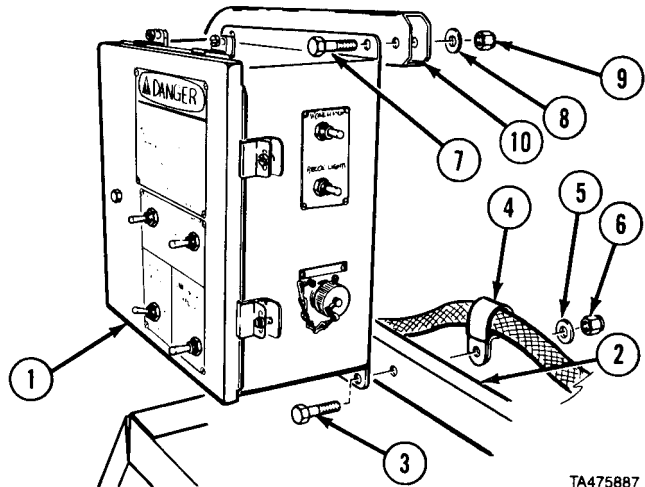
- (2) Remove two locknuts (4), washers (5), and screws (6) from bracket (7).
- (3) Remove two locknuts (8), washers (9), clamps (10), screws (11), and remove control box (12) from bracket (13).



TA475886

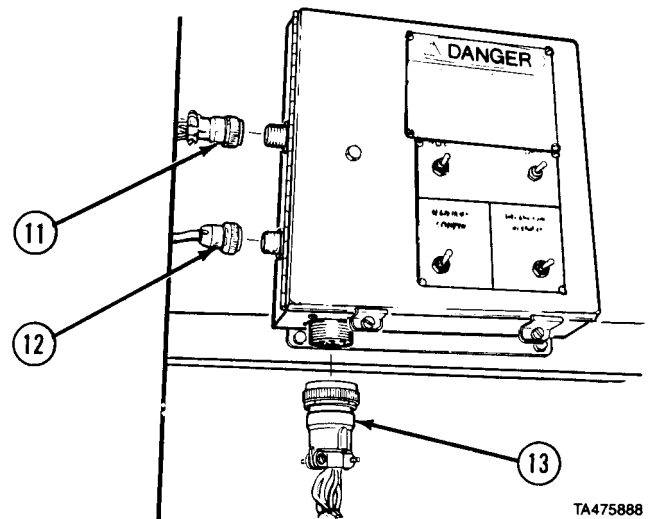
b. Control Box Installation.

- (1) Install control box (1) on bracket (2) with two screws (3), clamps (4), washers (5), and locknuts (6).
- (2) Install two screws (7), washers (8), and locknuts (9) on bracket (10).



TA475887

- (3) Connect three connectors (11, 12, and 13).

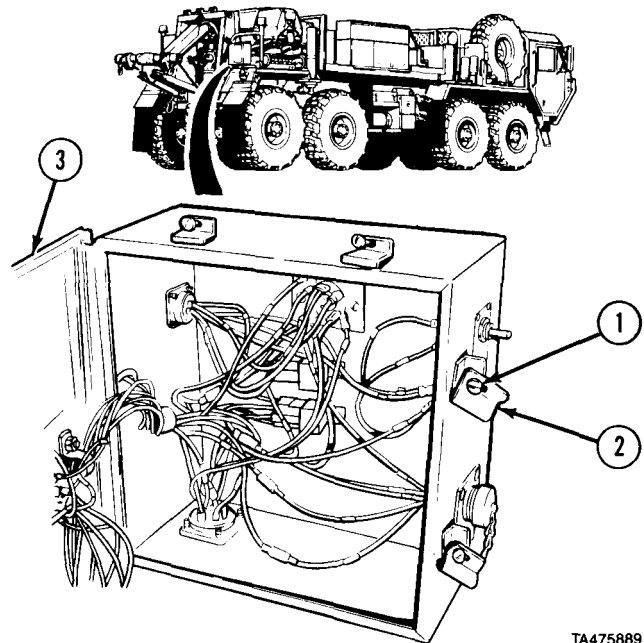


TA475888

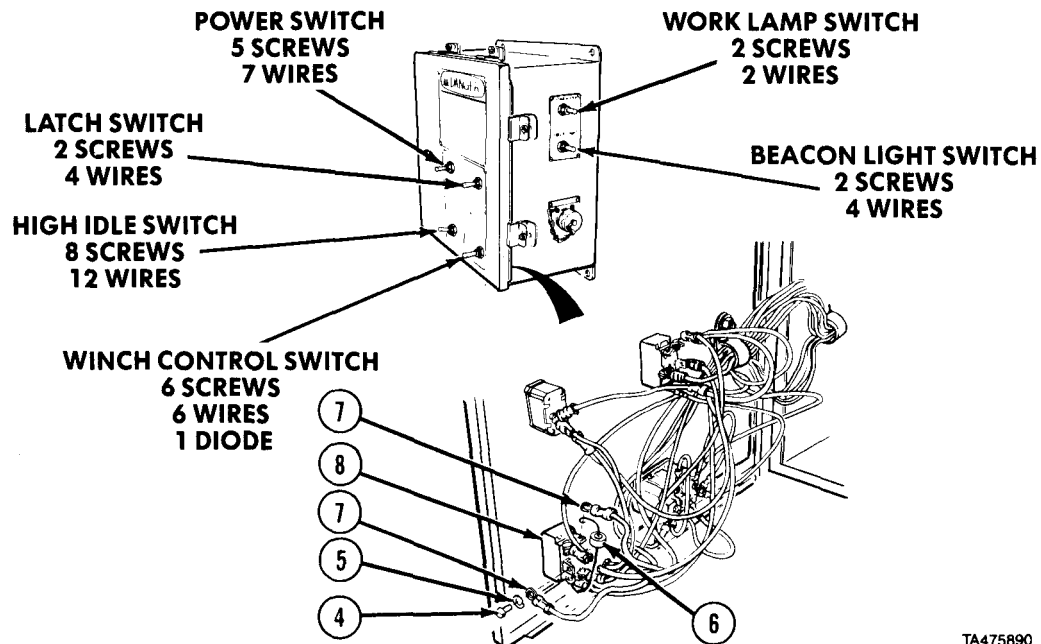
Electrical System Maintenance Instructions (Cont)

c. Control Box Switches Removal.

- (1) Loosen six screws (1), brackets (2), and open cover (3).



TA475889



TA475890

NOTE

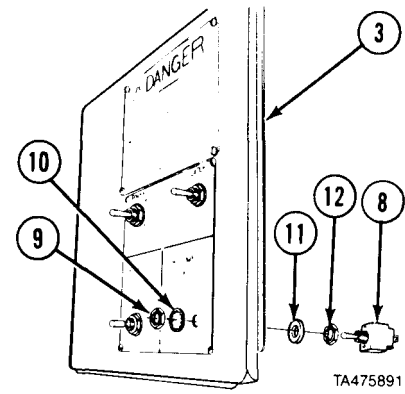
- Tag and mark all wires before removing.
- All switches are removed the same. Number of screws and wires will vary.
- Winch control switch is only switch with diode.

- (2) Remove screws (4), lockwashers (5), diode (6), and wires (7) from switch (8) as required.

Electrical System Maintenance Instructions (Cont)

7-52.1 CONTROL BOX REMOVAL/REPAIR/INSTALLATION (M984E1) (CONT).

- (3) Remove nut (9), lockwasher (10), and switch (8) from cover (3).
- (4) Remove panel seal (11) and nut (12) from switch (8).

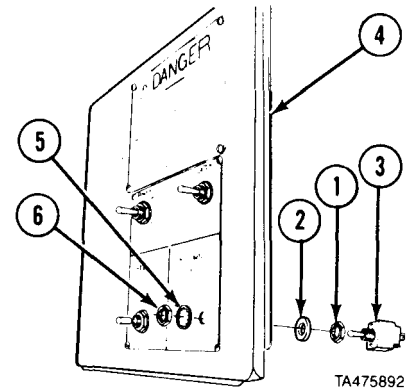


d. Control Box Switches Installation.

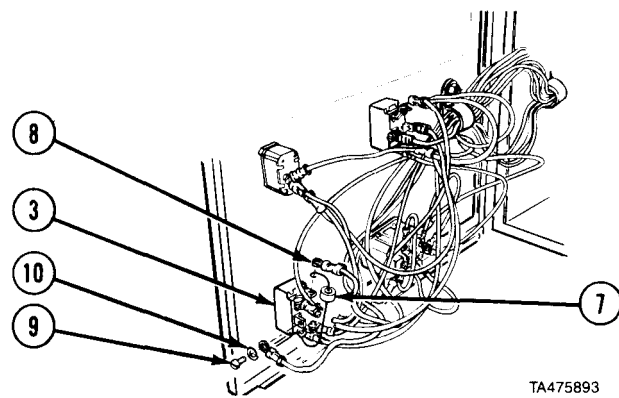
NOTE

- All switches are installed the same. Number of screws and wires will vary.
- Install sealing washer so that the surface marked **BOTTOM** is towards switch.

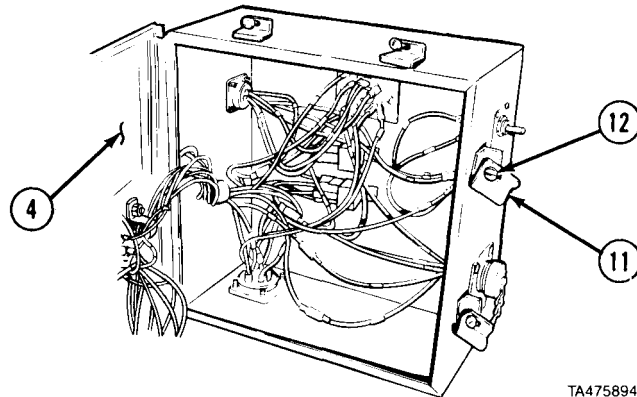
- (1) Install nut (1) and panel seal (2) on switch (3).
- (2) Install switch (3) on cover (4) with lockwasher (5) and nut (6).



- (3) Install diode (7) and wires (8) on switch (3) with screws (9) and lockwashers (10) as required.

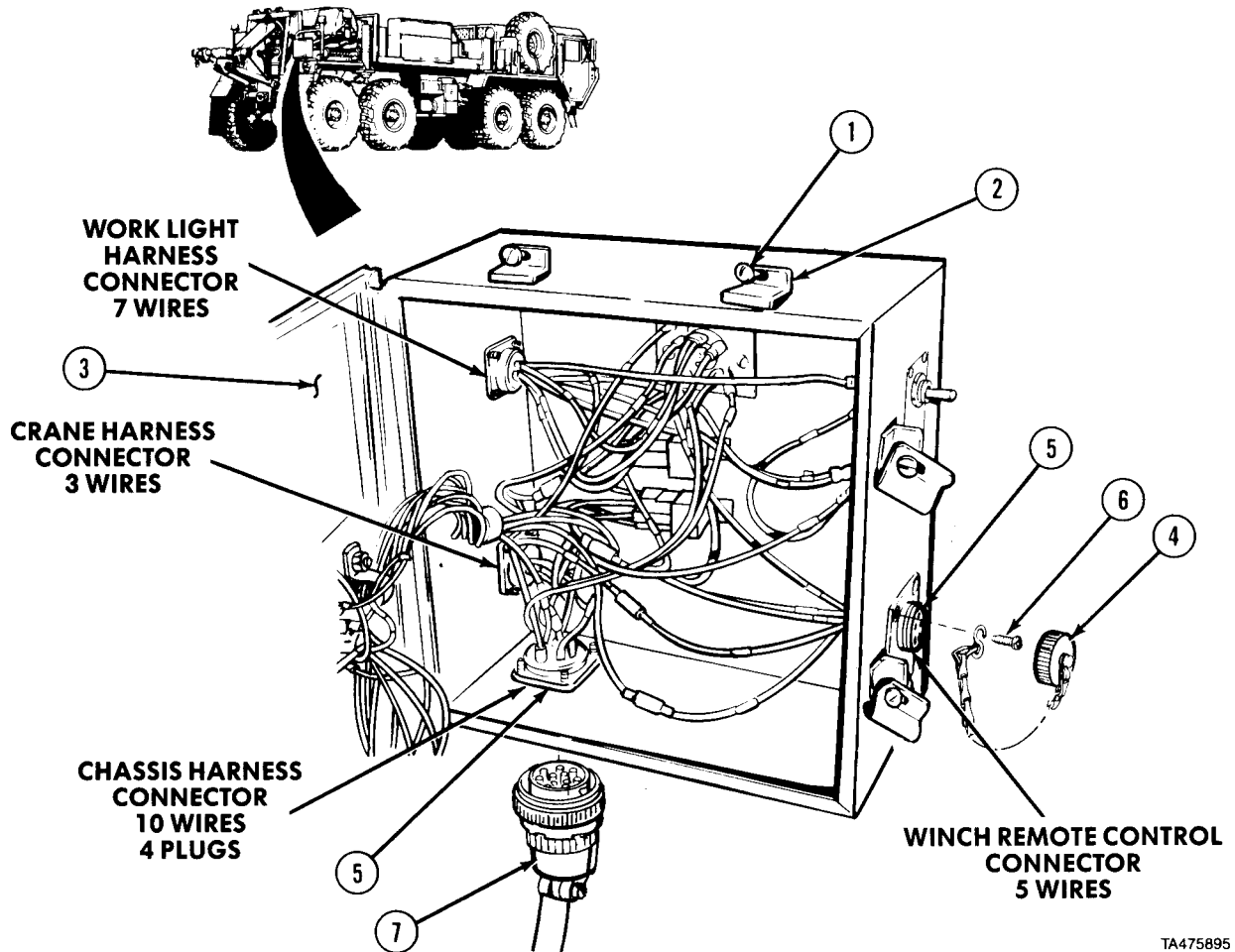


- (4) Close cover (4) and tighten six brackets (11) with screws (12).



Electrical System Maintenance Instructions (Cont)

e. Control Box Connectors Removal.



TA475895

(1) Loosen six screws (1), brackets (2), and open cover (3).

NOTE

- Tag and mark all wires before removing.
- All connectors are removed the same way. Number of wires will vary.
- Do steps (2) and (3) for winch remote control connectors.

(2) Disconnect cap and chain (4) from winch remote control connector (5).

(3) Remove screw (6) and cap and chain (4) from winch remote control connector (5).

(4) Disconnect cable connectors (7) from connectors (5).

Electrical System Maintenance Instructions (Cont)

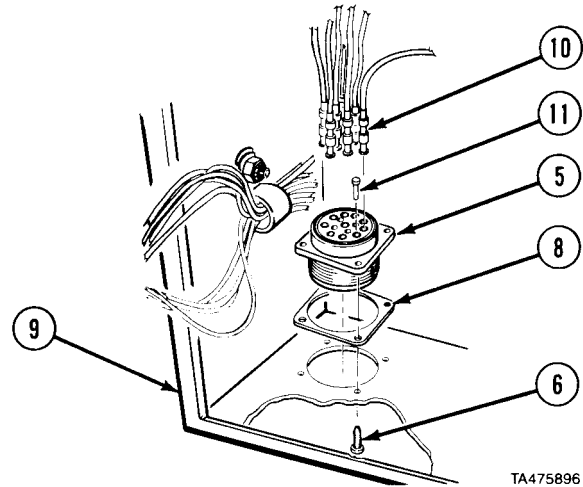
7-52.1. CONTROL BOX REMOVAL/REPAIR/INSTALLATION (M984E1) (CONT).

NOTE

- Chassis harness connector has 4 plugs. Note position of plugs.
- Mark position of connector in control box.
- Chassis harness connector shown. All connectors similar.

(5) Remove four screws (6), gasket (8), and connector (5) from control box (9).

(6) Remove wires (10) and plugs (11) from connector (5).



f. Control Box Connectors Installation.

NOTE

- Installation of harness connectors is similar. Winch remote control and chassis harness connectors are different.
- Aline matchmarks on connectors and control box.

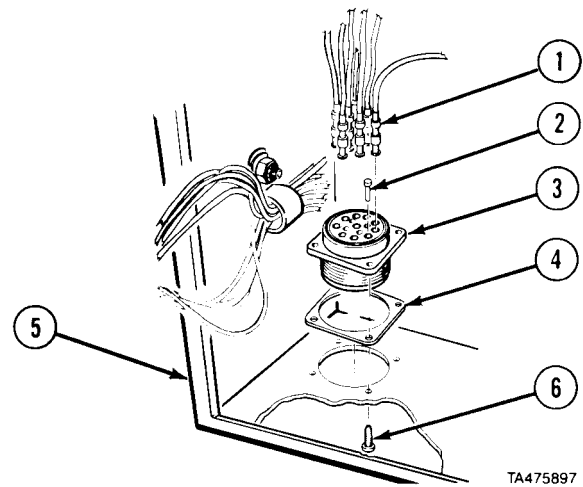
(1) Install wires (1) and plugs (2) in connector (3).

WARNING

Adhesives, solvents, and sealing compounds can burn easily, can give off harmful vapors, and are harmful to skin and clothing. To avoid injury or death, keep away from open fire and use in well-ventilated area. If adhesive, solvent, or sealing compound gets on skin or clothing, wash immediately with soap and water.

(2) Apply thin coat of adhesive-sealant to connector (3) and gasket (4) and install in control box (5).

(3) Apply corrosion treatment to area where wires (1) enter connector (3).



NOTE

Do step (4) for winch remote control connector. Do step (5) for other connectors.

(4) Install three screws (6) in connector (3).

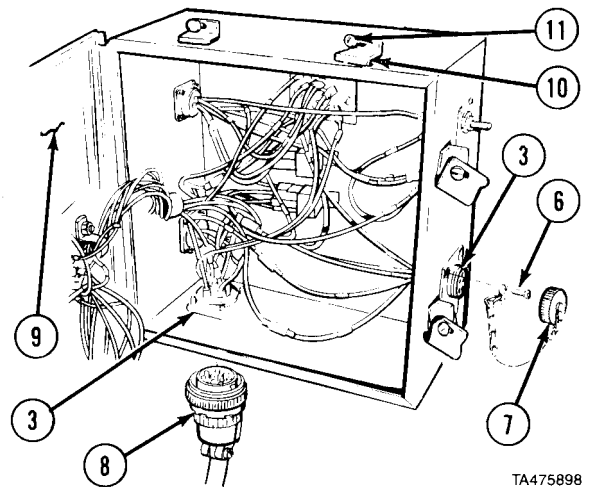
(5) Install four screws (6) in connector (3).

Electrical System Maintenance Instructions (Cont)

NOTE

Do step (6) for winch remote control connector.

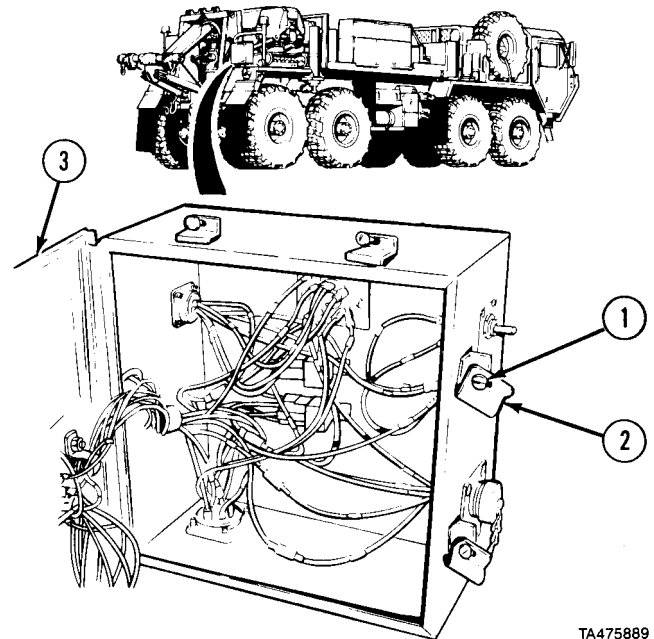
- (6) Install screw (6) and cap and chain (7) on winch remote control connector (3). Install cap and chain on connector.
- (7) Connect cable connectors (8) to connectors (3).
- (8) Close cover (9) and tighten six brackets (10) and screws (11).



TA475898

g. Control Box Relays Removal.

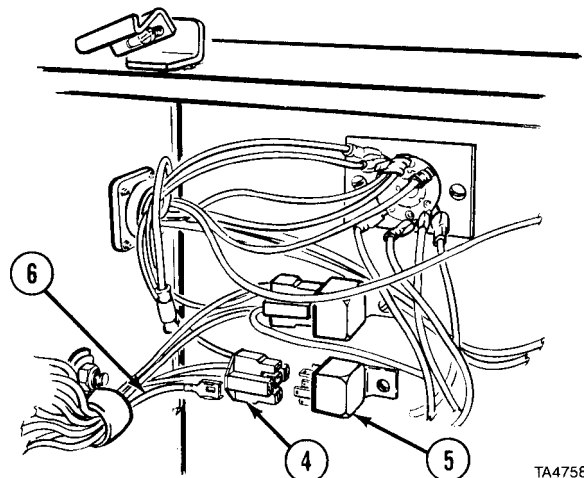
- (1) Loosen six screws (1), brackets (2), and open cover (3).



TA475889

NOTE

- Both relays are removed the same way.
- Tag and mark wires before removing.
 - (2) Disconnect connector (4) from relay (5).
 - (3) Remove four wires (6) from connector (4).

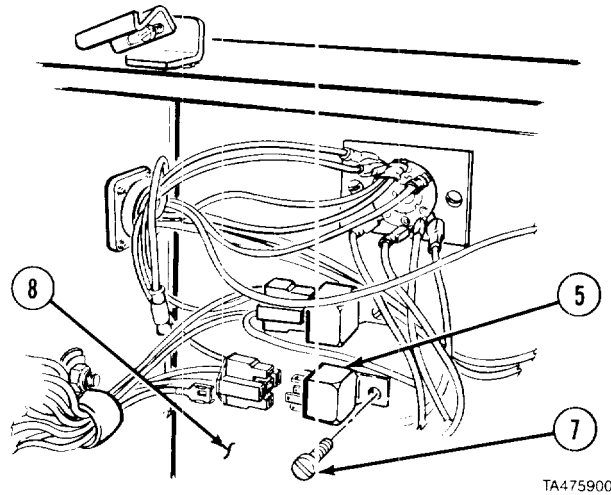


TA475899

Electrical System Maintenance Instructions (Cont)

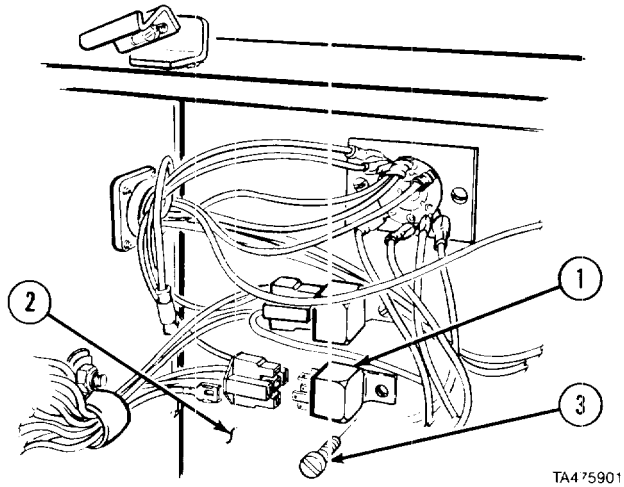
17-52.1. CONTROL BOX REMOVAL/REPAIR/INSTALLATION (M984E1) (CONT).

(4) Remove screw (7) and relay (5) from mounting plate (8).

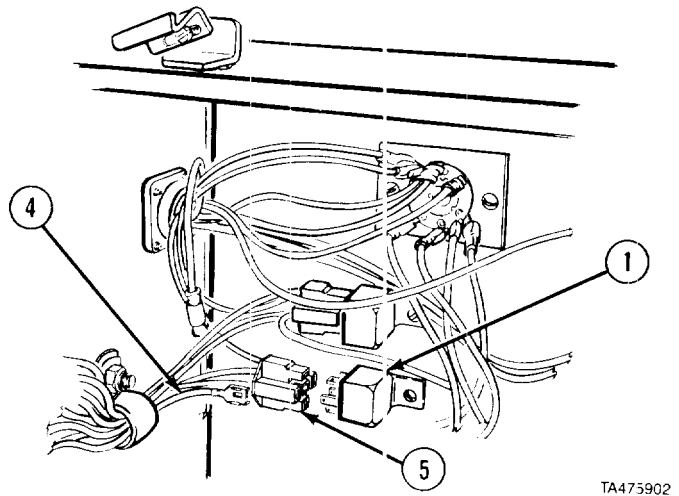


h. Control Box Relays Installation.

(1) Install relay (1) on mounting plate (2) with screw (3).

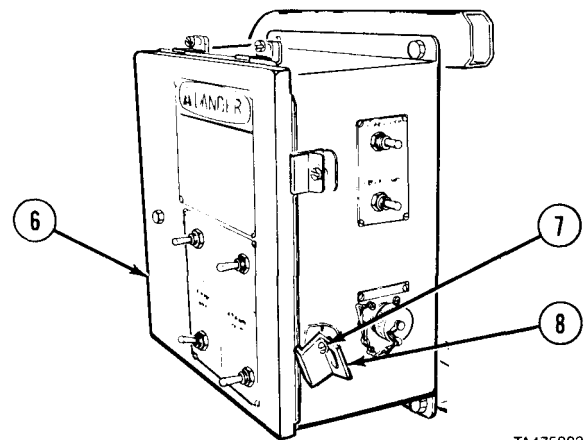


(2) Install four wires (4) on connector (5).
(3) Install connector (5) on relay (1).



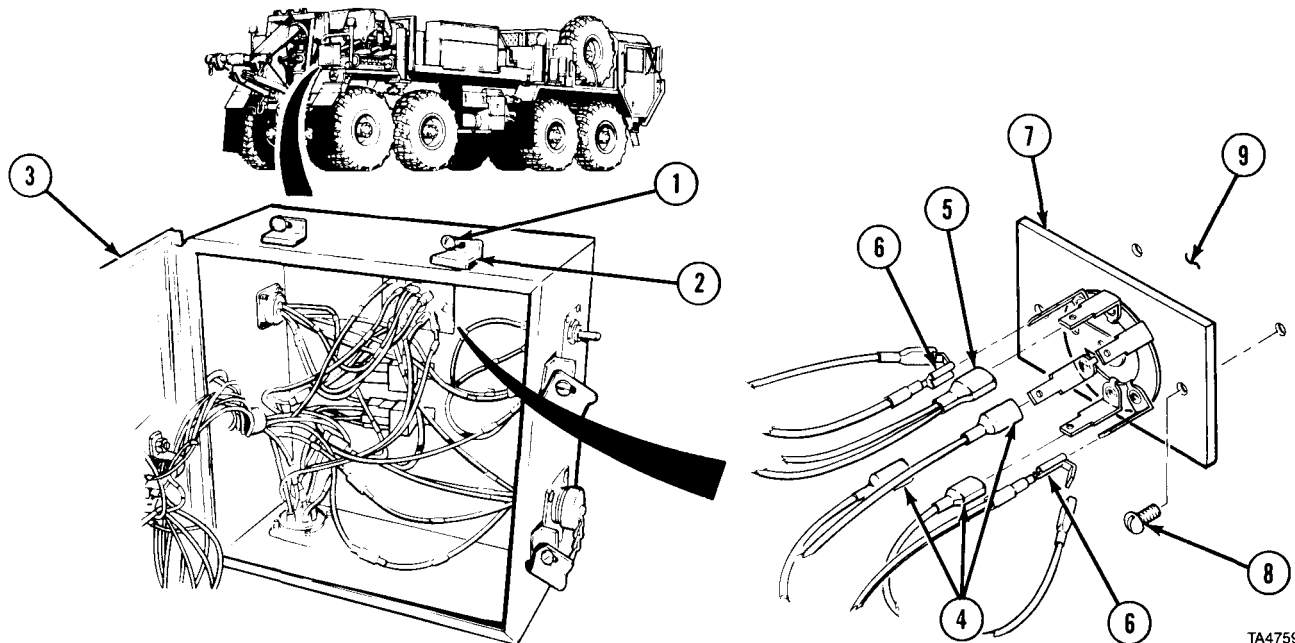
Electrical System Maintenance Instructions (Cont)

- (4) Close cover (6) and tighten six brackets (7) with six screws (8).



TA475903

i. Control Box Junction Block Removal.



TA475904

- (1) Loosen six screws (1), brackets (2) and open cover (3).

NOTE

Tag and mark all wires before removing.

- (2) Disconnect three wires (4), wire (5), and two wires (6) from junction block (7).
 (3) Remove two screws (8) and junction block (7) from mounting plate (9).

j. Control Box Junction Block Installation.

- (1) Install junction block (7) on mounting plate (9) with two screws (8).
 (2) Connect two wires (6), wire (5), and three wires (4) on junction block (7).
 (3) Close cover (3) and tighten six brackets (2) with screws (1).

k. Follow-on Maintenance.

- (1) Connect batteries (para 7-91).
 (2) Check operation of M984E1 control box (TM 9-2320-279-10).

END OF TASK

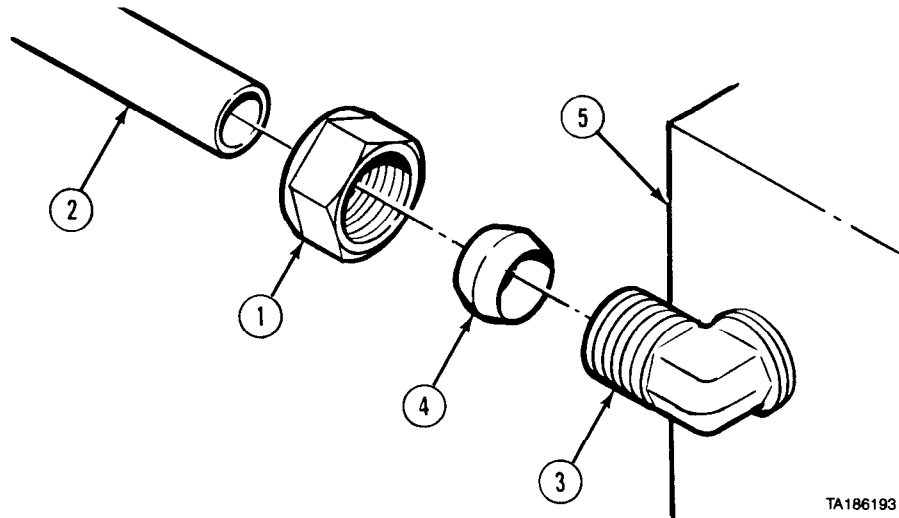
Electrical System Maintenance Instructions (Cont)

| | |
|--|---|
| 7-53. TANKER CONDUIT TUBING REMOVAL/INSTALLATION (M978). | |
| This task covers: | |
| a. Typical Conduit Tubing Removal | c. Conduit Tubing Removal/Installation |
| b. Typical Conduit Tubing Installation | d. Follow-on Maintenance |
| INITIAL SETUP | |
| <i>Models</i> | <i>Equipment Condition</i> |
| M978 | <i>TM or Para</i> <i>Condition Description</i> |
| <i>Test Equipment</i> | TM 9-2320-279-10 Tanker prepared for operation. |
| None | TM 9-2320-279-10 Pump module top and rear access doors opened. |
| <i>Special Tools</i> | Para 16-48 Pump module top and side access panels removed. |
| None | Para 7-91 Batteries disconnected. |
| <i>Supplies</i> | <i>Special Environmental Conditions</i> |
| Compound, sealing, pipe thread, Item 18, Appendix C | None |
| <i>Personnel Required</i> | <i>General Safety Instructions</i> |
| MOS 63S, Heavy wheel vehicle mechanic | No smoking, flame, sparks, hot or glowing objects within 50 ft (15 m) of vehicle. |
| <i>References</i> | |
| None | |

Electrical System Maintenance Instructions (Cont)

7-53. TANKER CONDUIT TUBING REMOVAL/INSTALLATION (M978) (CONT).

a. Typical Conduit Tubing Removal



NOTE

- This procedure is for reference only to show location of M978 tanker conduit tubing. It will never be necessary to remove all the conduit tubing at once. Refer to paragraph 7-53.c for locations of specific conduit tubing sections.
- All aluminum and plastic electrical conduit tubing on the M978 is connected with compression fittings. Fitting from which conduit tube is being removed or installed can be an elbow, tee, or adapter on an electrical light, junction box, or other electrical component. To disconnect or connect wiring before conduit tube removal or installation, refer to specific removal/installation task.
- All compression fittings are removed and installed the same way. Elbow is shown.
- Read paragraph 25-2.b before removing conduit tubing.

- (1) Remove nut (1) and tube (2) from elbow (3).
- (2) Remove compression ring (4) from tube (2).
- (3) Remove elbow (3) from component (5).

b. Typical Conduit Tubing Installation.

WARNING

Adhesives, solvents, and sealing compounds can burn easily, can give off harmful vapors, and are harmful to skin and clothing. To avoid injury or death, keep away from open fire and use in well-ventilated area. If adhesive, solvent, or sealing compound gets on skin or clothing, wash immediately with soap and water.

- (1) Coat threads of elbow (3) with pipe thread sealing compound and install in component (5).
- (2) Position nut (1) on tube (2) and install compression ring (4).
- (3) Install nut (1) and tube (2) on elbow (3).

Electrical System Maintenance Instructions (Cont)

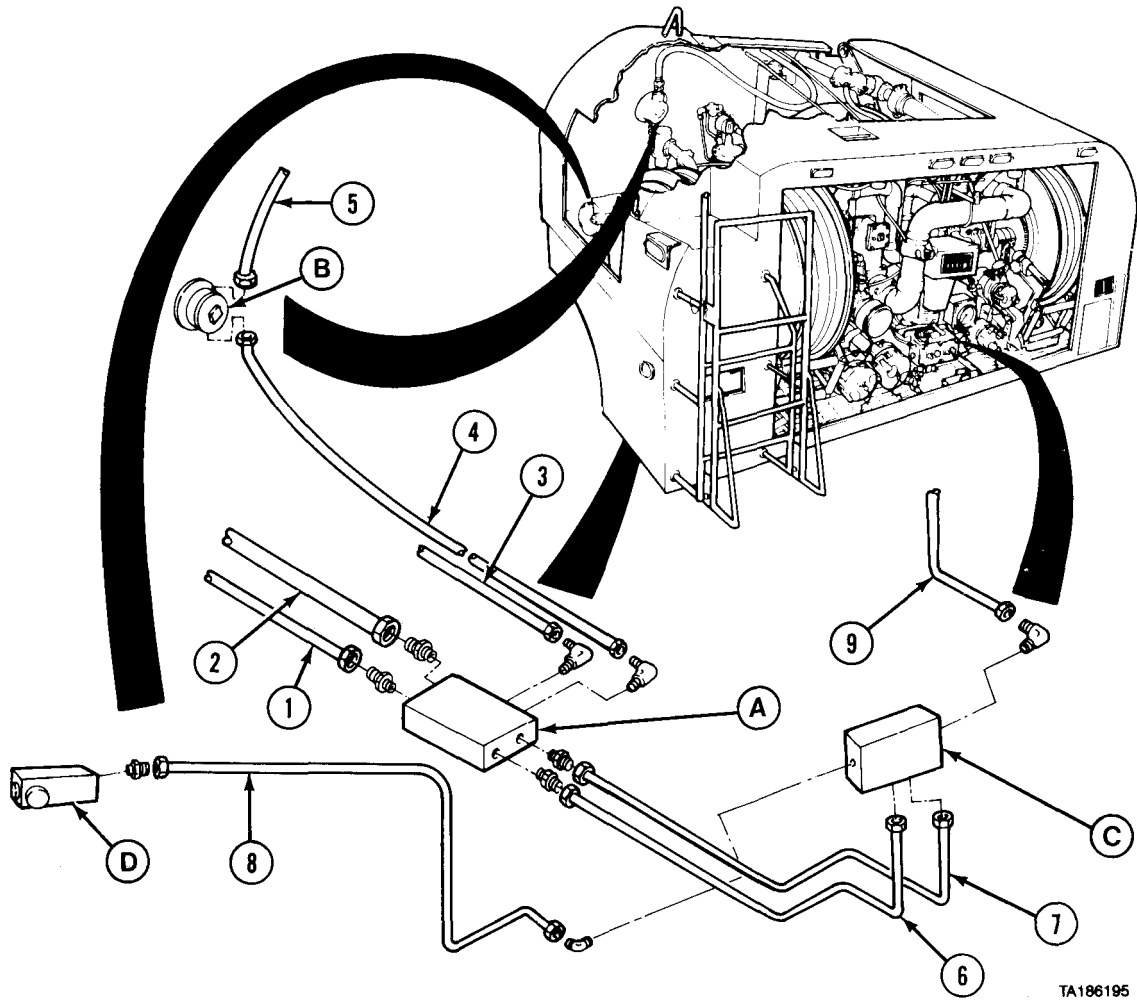
c. *Conduit Tubing Removal/Installation.* Refer to Table 7-1 and Figure 7-4 for location of specific tubing sections.

Table 7-1. Tanker Conduit Tubing

| Tube No. | From | To | Refer To Figure |
|----------|---|---|-----------------|
| 1 | Chassis Wiring Harness (inside left frame rail, single wire plug) | Main Junction box (a) | 7-4 |
| 2 | Main Junction Box (a) | Chassis Wiring Harness (inside left front rail, four wire plug) | 7-4 |
| 3 | Main Junction Box (a) | Clearance lights (on front of tank) | 7-4 |
| 4 | Main Junction Box (a) | Tank Level Sensor Adjuster (b) | 7-4 |
| 5 | Tank Level Sensor Adjuster (b) | Tank Level Sensor (on top of tank) | 7-4 |
| 6 | Main Junction Box (a) | Control Junction Box (c) | 7-4 |
| 7 | Main Junction Box (a) | Control Junction Box (c) | 7-4 |
| 8 | Control Junction Box (c) | Auxiliary Pump Junction Box (d) | 7-4 |
| 9 | Control Junction Box (c) | Right Module Interior Light (e) | 7-4 |
| 10 | Right Module Interior Light (e) | (Right) Side and Rear Clearance Lights (f) | 7-4 |
| 11 | Right Module Interior Light (e) | Left Module Interior Light (g) | 7-4 |
| 12 | Left Module Interior Light (g) | (Left) Side and Rear Clearance Lights (h) | 7-4 |
| 13 | Left Module Interior Light (g) | Three Center Rear Clearance Lights (j) | 7-4 |

Electrical System Maintenance Instructions (Cont)

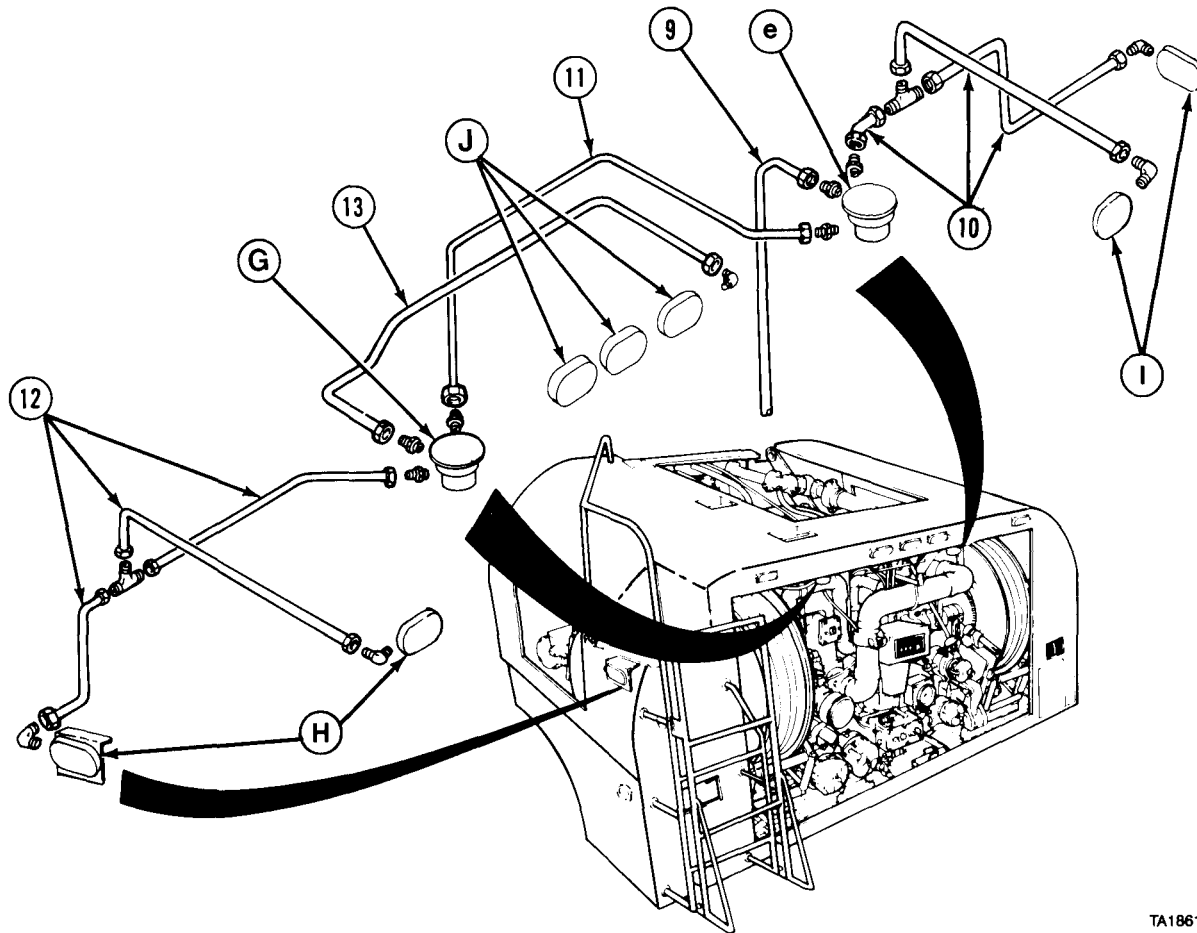
7-53. TANKER CONDUIT TUBING REMOVAL/INSTALLATION (M978) (CONT).



TA186195

Figure 7-4. Electrical Conduit Tubing (Sheet 1 of 2).

Electrical System Maintenance Instructions (Cont)



TA186196

Figure 7-4. Electrical Conduit Tubing (Sheet 2 of 2).

d. Follow-on Maintenance.

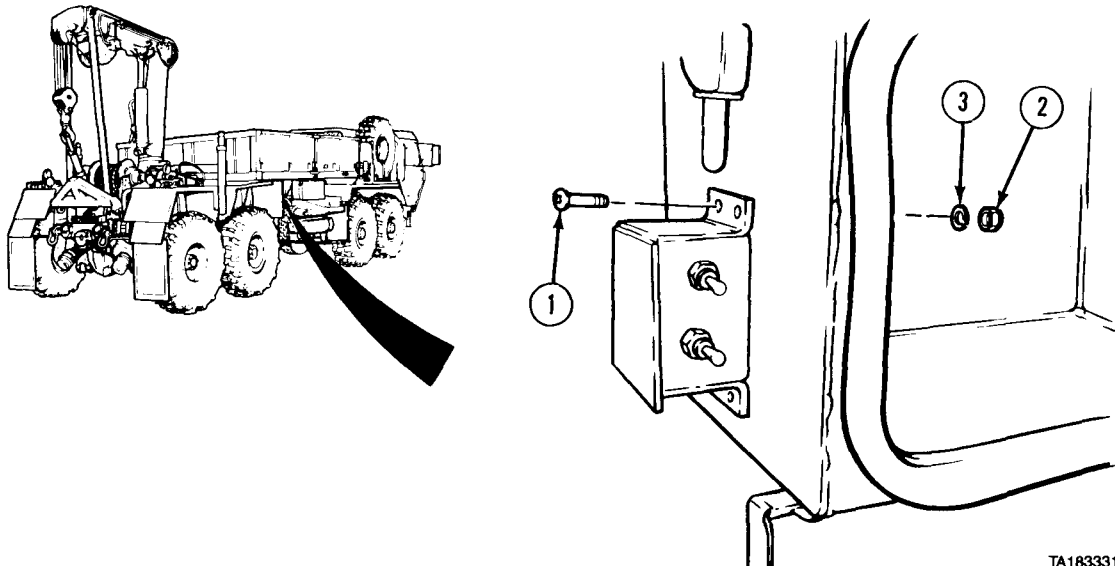
- (1) Connect batteries (para 7-91).
- (2) Check pump module for proper operation (TM 9-2320-279-10).
- (3) Close pump module top and rear access doors (TM 9-2320-279-10).
- (4) Install pump module top and side access panels (para 16-48).

END OF TASK

Electrical System Maintenance Instructions (Cont)

| | |
|---|--|
| 7-54. OUTRIGGER SWITCH BOX REMOVAL/INSTALLATION (M984). | |
| This task covers: | |
| a. Removal | c. Follow-on Maintenance |
| b. Installation | |
| INITIAL SETUP | |
| <i>Models</i> | <i>References</i> |
| M984 | None |
| <i>Test Equipment</i> | <i>Equipment Condition</i> |
| None | <i>TM or Para</i> <i>Condition Description</i> |
| <i>Special Tools</i> | Para 7-91 Batteries disconnected. |
| None | TM 9-2320-279-10 Stowage box open. |
| <i>Supplies</i> | <i>Special Environmental Conditions</i> |
| Tags, identification, Item 48, Appendix C | None |
| <i>Personnel Required</i> | <i>General Safety Instructions</i> |
| MOS 63S, Heavy wheel vehicle mechanic | None |

a. Removal.



(1) Remove four screws (1), nuts (2), and lockwashers (3).

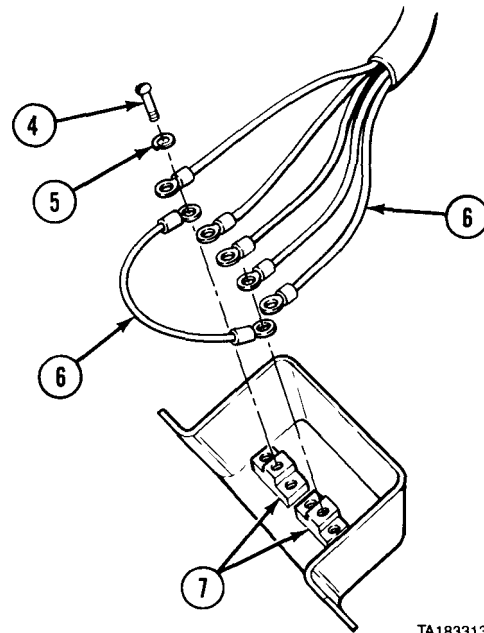
TA183331

Electrical System Maintenance Instructions (Cont)

NOTE

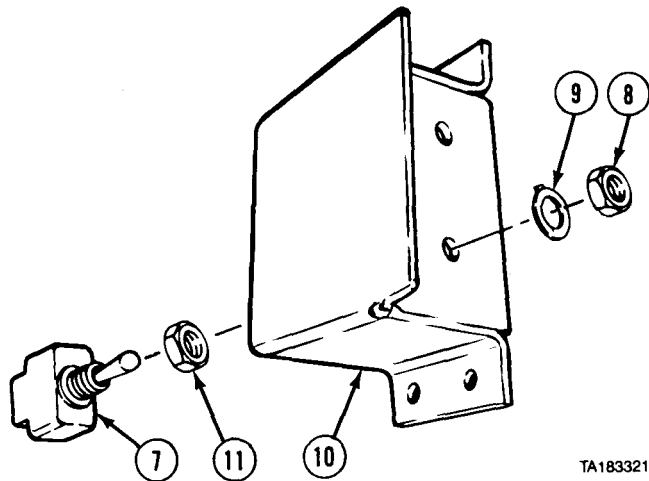
Tag and mark wires before removing.

- (2) Remove six screws (4), lockwashers (5), and wires (6) from two outrigger switches (7).



TA183313

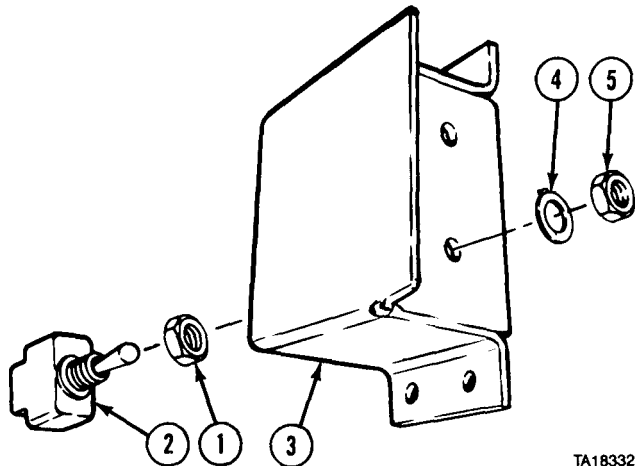
- (3) Remove two nuts (8) and retaining rings (9) from two outrigger switches (7). Remove two outrigger switches from outrigger switch box (10).
- (4) Remove two nuts (11).



TA183321

b. Installation.

- (1) Install two nuts (1) on two outrigger switches (2).
- (2) Install two outrigger switches (2) in outrigger switch box (3) with two retaining rings (4) and nuts (5).

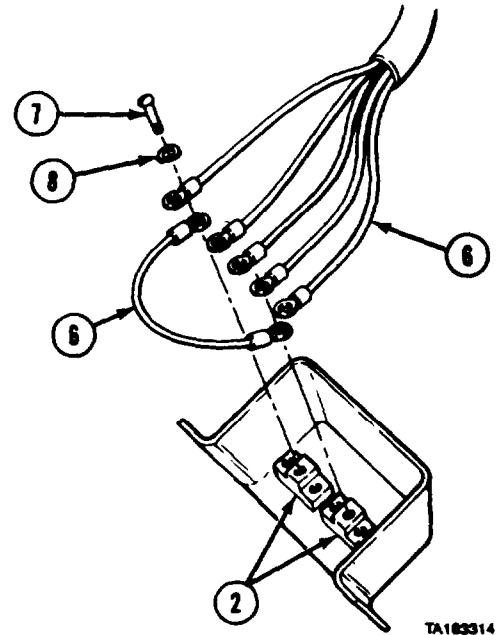


TA183322

Electrical System Maintenance Instructions (Cont)

7-54. OUTRIGGER SWITCH BOX REMOVAL/INSTALLATION (M984) (CONT).

- (3) Install six wires (6) on two outrigger switches (2) with six screws (7) and lockwashers (8).



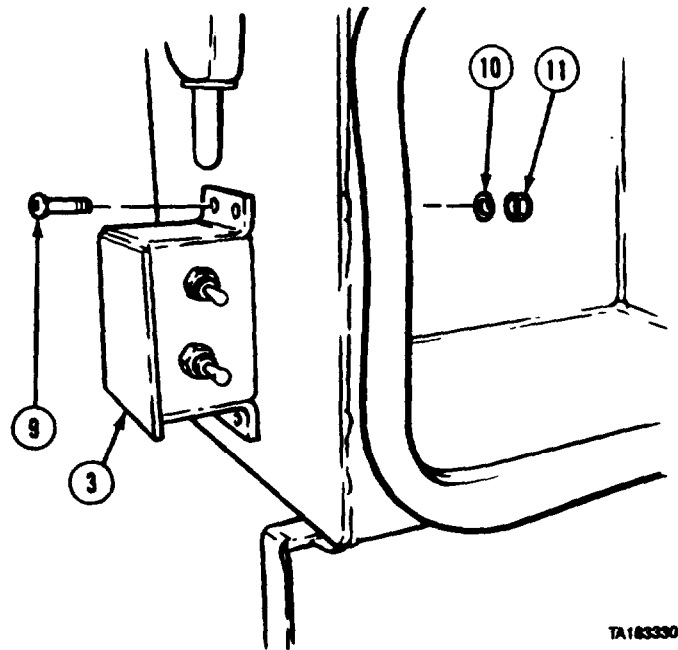
TA103314

- (4) Install outrigger switch box (3) with four screws (9), lockwashers (10), and nuts (11).

c. Follow-on Maintenance.

- (1) Connect batteries (para 7-91).
- (2) Close stowage box (TM 9-2320-279-10).
- (3) Start engine (TM 9-2320-279-10).
- (4) Check outrigger switch operation (TM 9-2320-354-10).
- (5) Shut off engine (TM 9-2320-279-10).

END OF TASK

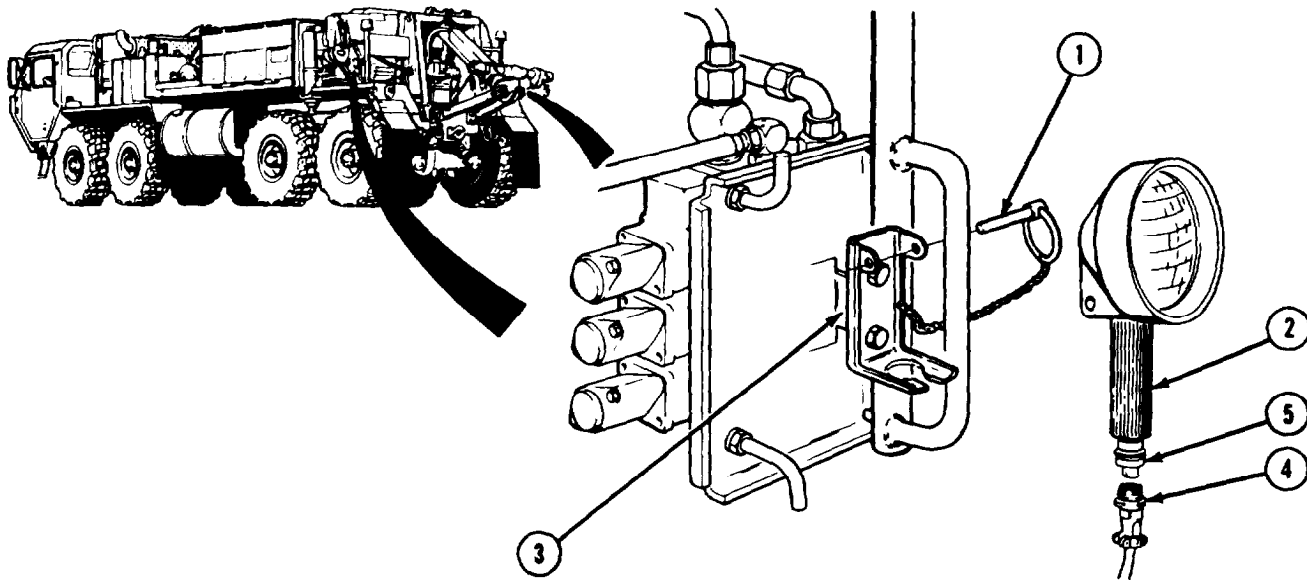


TA103330

Electrical System Maintenance Instructions (Cont)

| | |
|---|---|
| 7-54.1 REMOVABLE WORKLAMPS AND BRACKET REMOVAL/INSTALLATION (M984E1). | |
| This task covers: | |
| a. Removal b. Installation | c. Follow-on Maintenance |
| INITIAL SETUP | <i>Personnel Required</i> |
| <i>Models</i> M984E1 | MOS 63S, Heavy wheel vehicle mechanic |
| <i>Test Equipment</i> None | <i>References</i> None |
| <i>Special Tools</i> None | <i>Equipment Condition</i> TM or Para Para 7-91 |
| <i>Supplies</i> Connectors, electrical butt, Item 19, Appendix C Tags, identification, Item 48, Appendix C | <i>Condition Description</i> Batteries disconnected. |
| | <i>Special Environmental Conditions</i> None |
| | <i>General Safety Instructions</i> None |

a. Removal.



NOTE

Left and right worklamps are removed and installed in a similar manner.

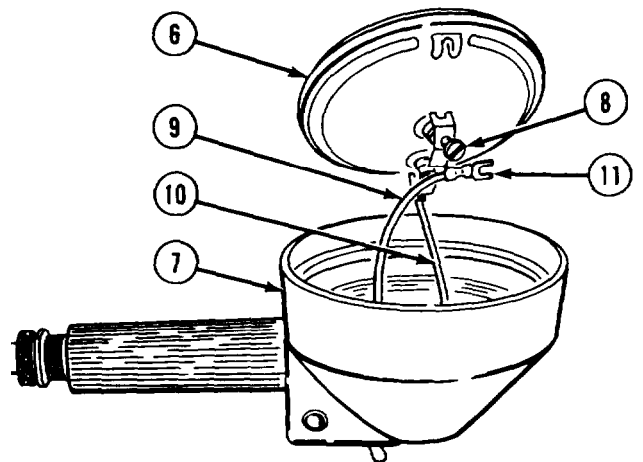
- (1) Remove pin (1) and worklamp (2) from bracket (3).
- (2) Disconnect connector (4) from connector (5).

Electrical System Maintenance Instructions (Cont)

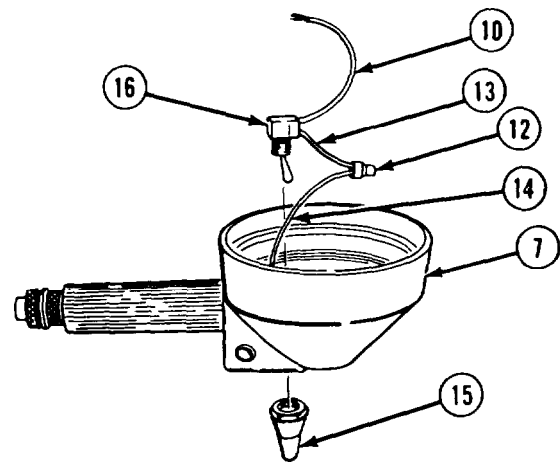
NOTE

Tag and mark all wires before removing.

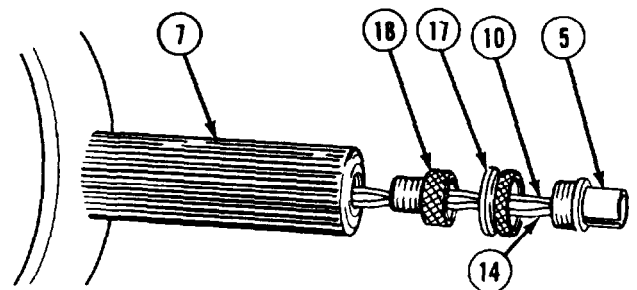
- (3) Remove lamp (6) from lamp housing (7).
- (4) Loosen two screws (8) and remove two wires (9 and 10) from lamp (6).
- (5) Remove two wire terminals (11) from wires (9 and 10).



- (6) Remove butt connector (12) from two wires (13 and 14).
- (7) Remove nut (15), switch (16), and two wires (10 and 13) from lamp housing (7).



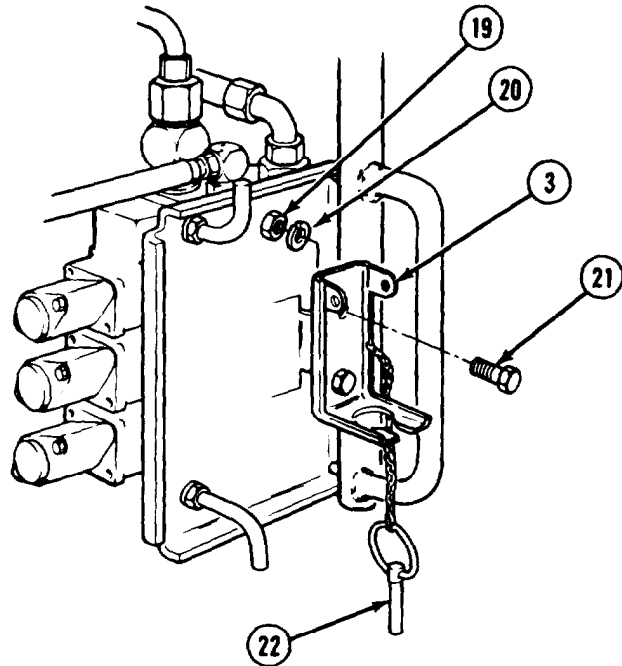
- (8) Deleted.
- (9) Remove connector (5), two wires (10 and 14), ring (17), and adapter (18) from lamp housing (7).
- (10) Remove two wires (10 and 14) from connector (5).



Electrical System Maintenance Instructions (Cont)

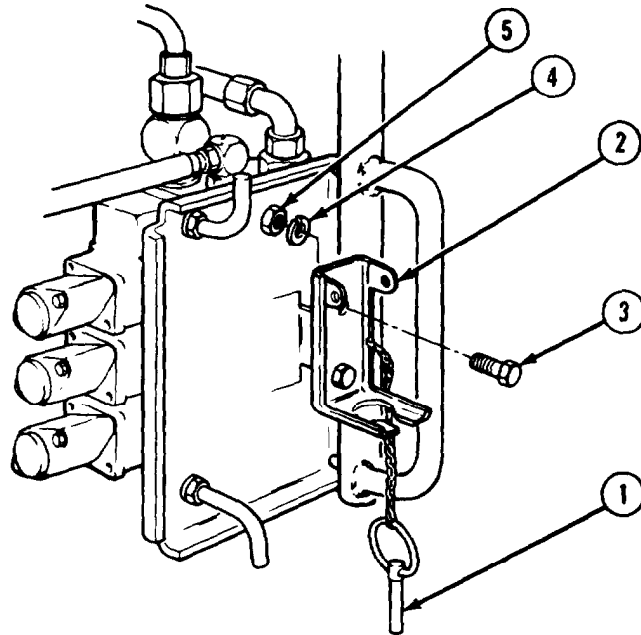
7-54.1 REMOVABLE WORKLAMPS AND BRACKET REMOVAL/INSTALLATION (M984E1) (CONT).

- (11) Remove two nuts (19), lockwashers (20), screws (21), and bracket (3).
- (12) Remove chain and pin assembly (22) from bracket (3).

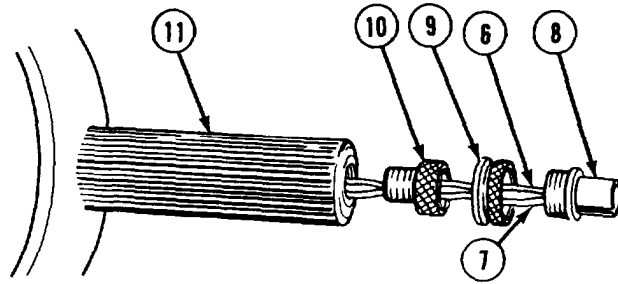


b. Installation.

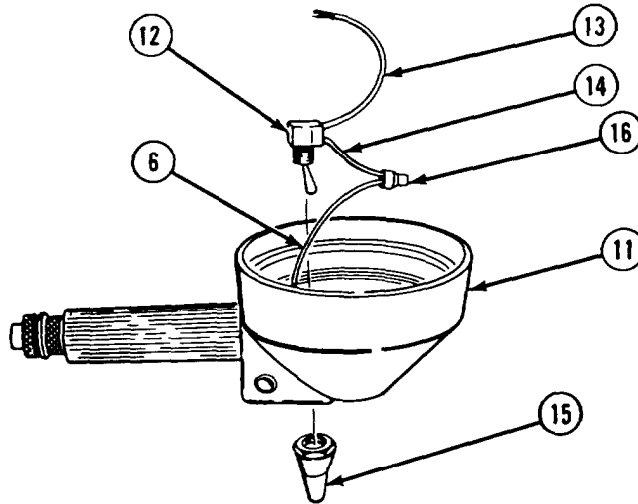
- (1) Install chain and pin assembly (1) on bracket (2).
- (2) Install bracket (2) with two screws (3), lockwashers (4), and nuts (5).



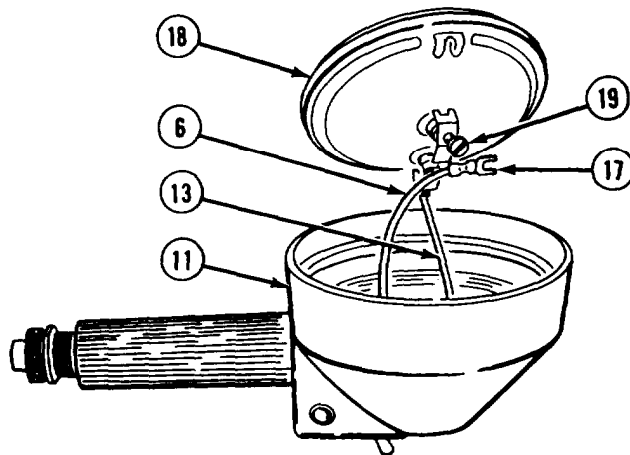
Electrical System Maintenance Instructions (Cont)



- (3) Install two wires (6 and 7) on connector (8).
- (4) Install ring (9) and adapter (10) on two wires (6 and 7).
- (5) Install adapter (10), ring (9), and connector (8) to lamp housing (11).



- (6) Deleted.
- (7) Install switch (12) and two wires (13 and 14) in lamp housing (11) with nut (15).
- (8) Install butt connector (16) on two wires (6 and 14).

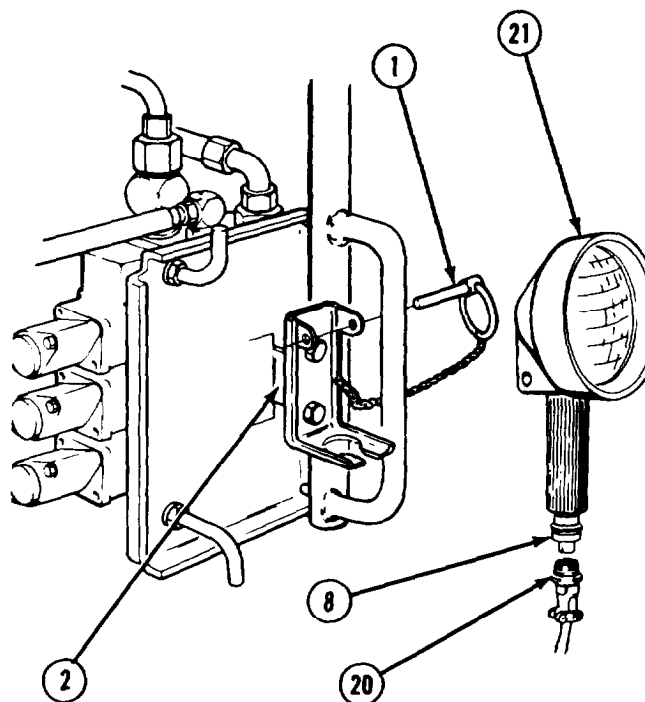


- (9) Install two wire terminals (17) on wires (6 and 13).
- (10) Install two wires (6 and 13) on lamp (18) with screws (19).
- (11) Install lamp (18) in lamp housing (11).

Electrical System Maintenance Instructions (Cont)

7-54.1 REMOVABLE WORKLAMPS AND BRACKET REMOVAL/INSTALLATION (M984E1) (CONT).

- (12) Connect connector (20) to connector (8).
- (13) Install worklamp (21) on bracket (2)



c. Follow-on Maintenance.

- (1) Connect batteries (para 7-91).
- (2) Check operation of worklamp (TM 9-2320-279-10).

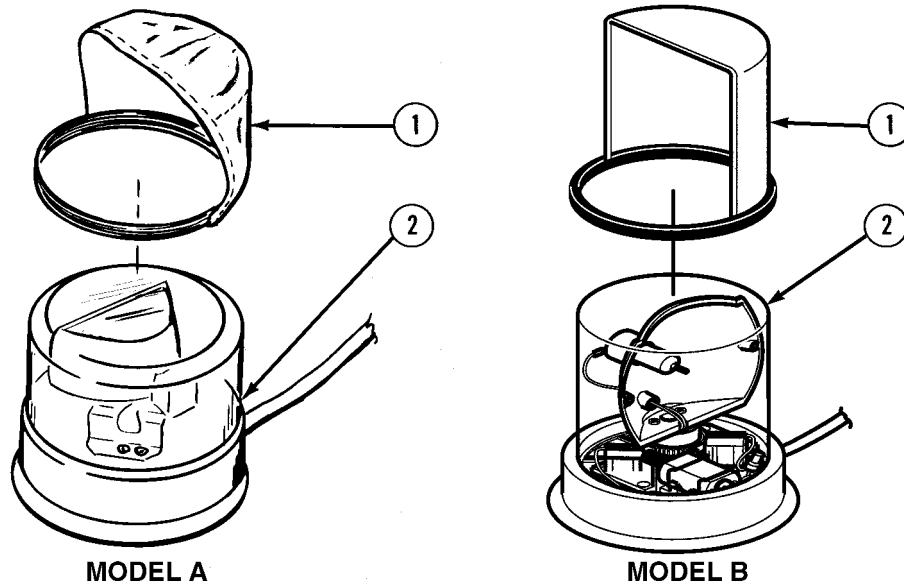
END OF TASK

Electrical System Maintenance Instructions (Cont)

Section VIII. LIGHTS

| | |
|--|--|
| 7-55. REMOVABLE WARNING LIGHT REPAIR (MODELS A AND B). | |
| This task covers: | |
| a. Disassembly | c. Follow-on Maintenance |
| b. Assembly | |
| INITIAL SETUP | |
| <i>Models</i> All | <i>References</i> None |
| <i>Test Equipment</i> None | <i>Equipment Condition</i> TM or Para |
| <i>Special Tools</i> None | <i>Condition Description</i> Light on clean work surface. |
| <i>Supplies</i> Adhesive, No. 4500, Item 1, Appendix C | <i>Special Environmental Conditions</i> None |
| <i>Personnel Required</i> MOS 63S, Heavy wheel vehicle mechanic | <i>General Safety Instructions</i> None |

a. Disassembly.



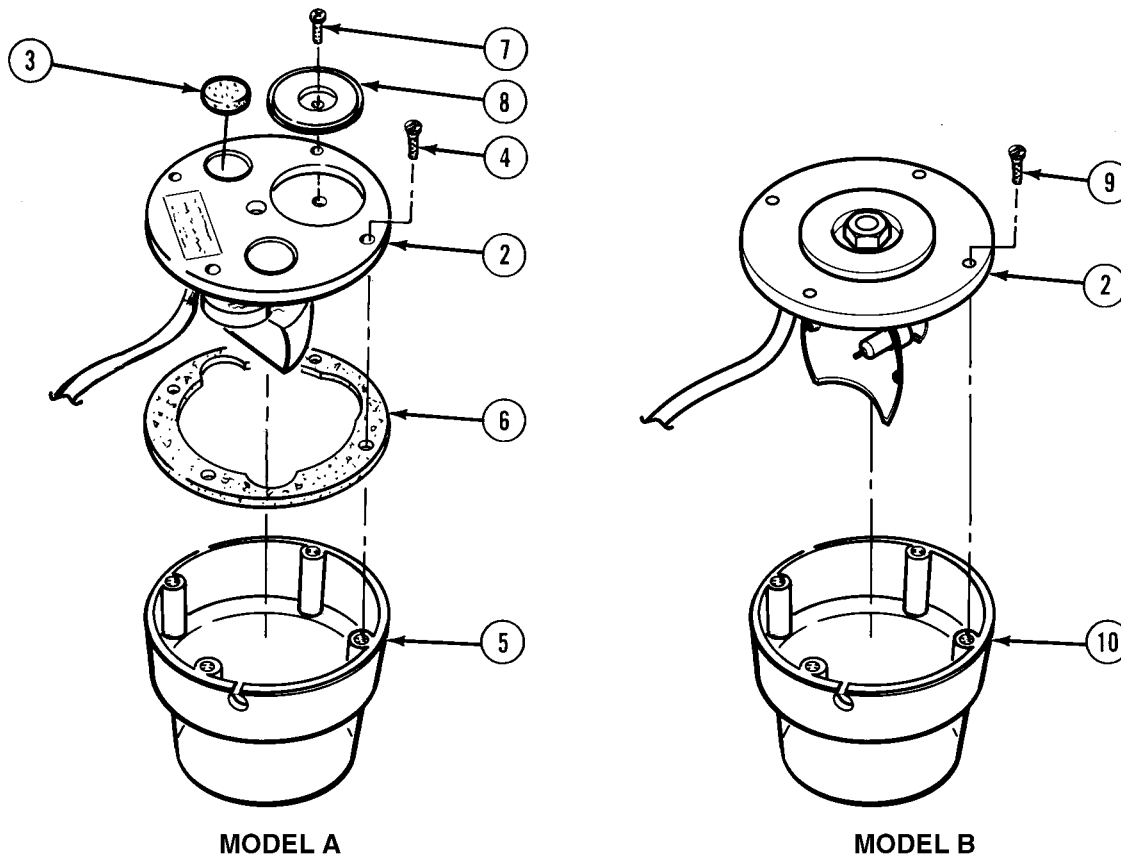
NOTE

There are two types of warning lights.

- (1) Remove protective shield (1) from light (2).

Electrical System Maintenance Instructions (Cont)

7-55. REMOVABLE WARNING LIGHT REPAIR (MODELS A AND B) (CONT).

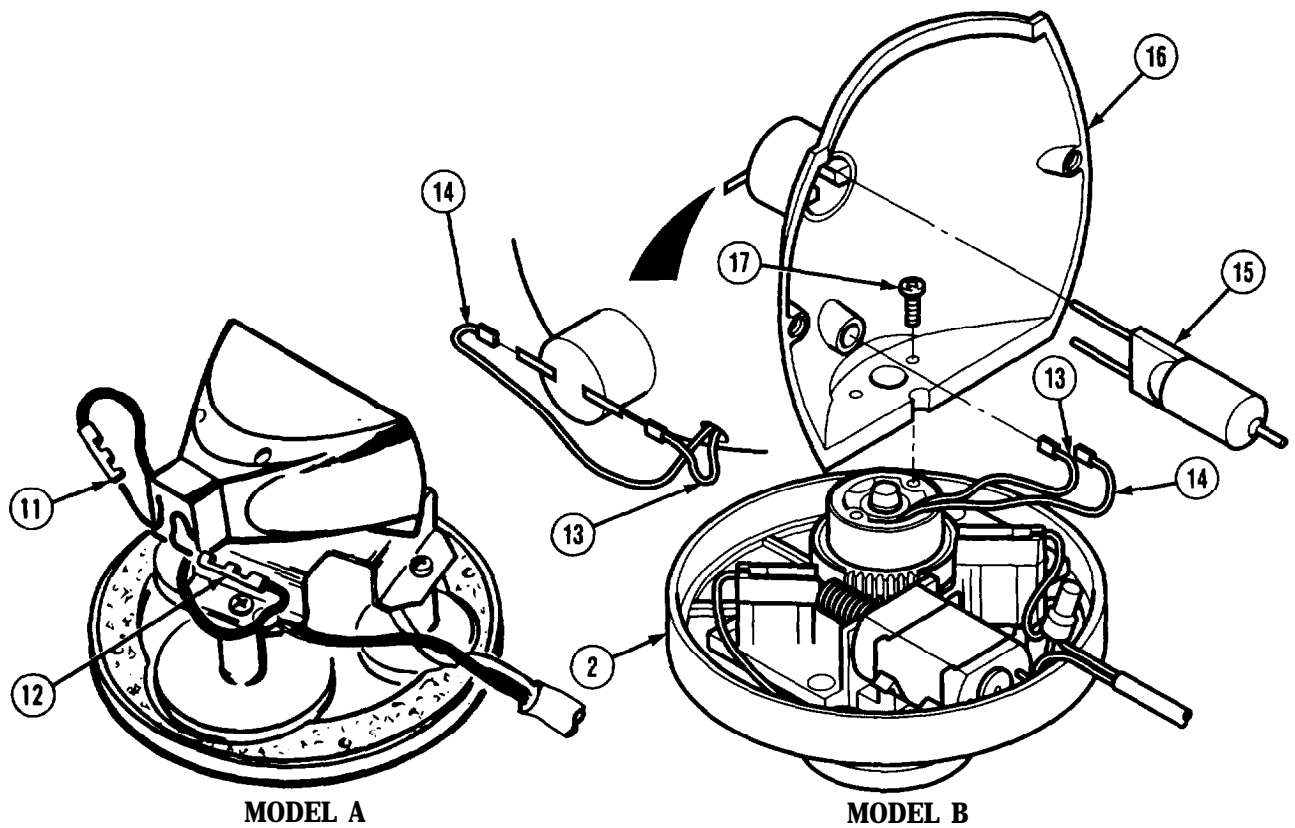


NOTE

- Model A has a magnet and two pads on base. Model B has a magnet only.
- Do steps (2) thru (4) for Model A.
- Do step (5) for Model B.

- (2) Remove two pads (3).
- (3) Remove four screws (4), dome (5), and gasket (6).
- (4) Remove screw (7) and magnet (8) from light (2).
- (5) Remove four screws (9) and dome (10) from light (2).

Electrical System Maintenance Instructions (Cont)



NOTE

- Model A has a sealed unit with a non-replaceable lamp. Model B has a replaceable lamp.
- Do step (6) for Model A.
- Do steps (7) thru (10) for Model B.
- Tag and mark wires prior to removal.

- (6) Disconnect two wires (11) and (12).
- (7) Disconnect two wires (13) and (14).
- (8) Remove lamp (15) from reflector (16).
- (9) Remove two wires (13) and (14) from reflector (16).
- (10) Remove two screws (17) and reflector (16) from light (2).

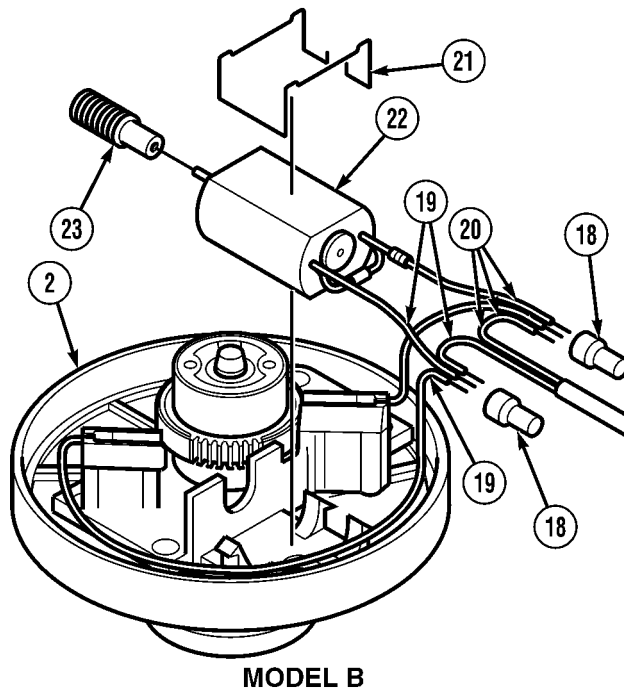
Electrical System Maintenance Instructions (Cont)

7-55. REMOVABLE WARNING LIGHT REPAIR (MODELS A AND B) (CONT).

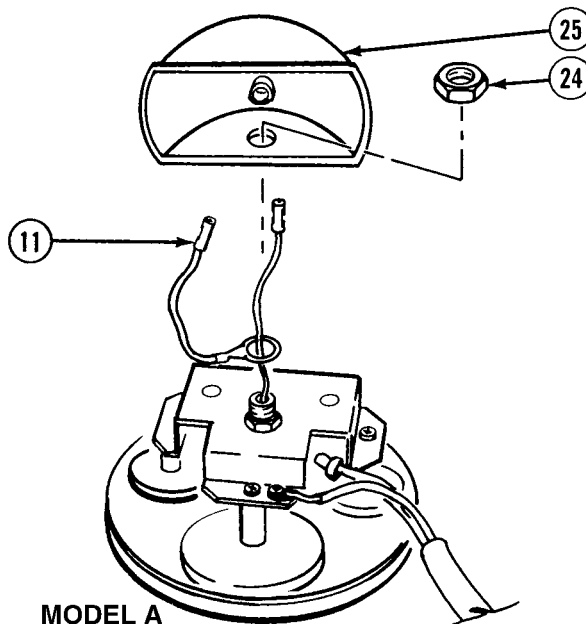
NOTE

- Model B has a replaceable worm gear on motor.
- Do steps (11) thru (13) for Model B.
- Do step (14) for Model A.
- Tag and mark all wires prior to removal.

- (11) Remove two terminal connectors (18) from wire connections (19) and (20).
- (12) Remove retainer (21), motor (22), and worm gear (23) from light (2).
- (13) Remove worm gear (23) from motor (22).



- (14) Remove nut (24), reflector (25), and wire (11).

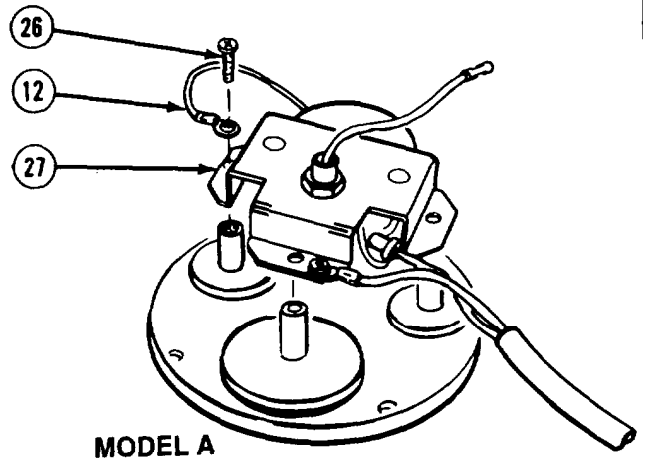


Electrical System Maintenance Instructions (Cont)

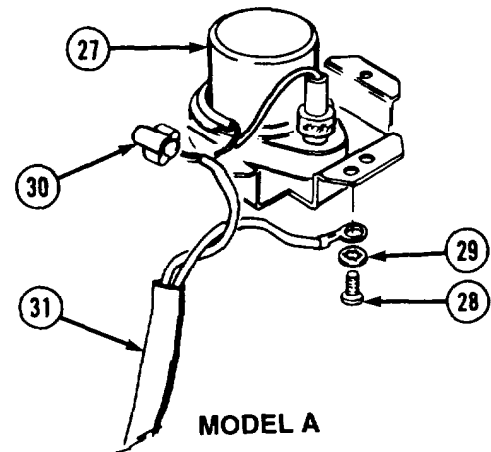
NOTE

Model A has a replaceable resistor on motor.

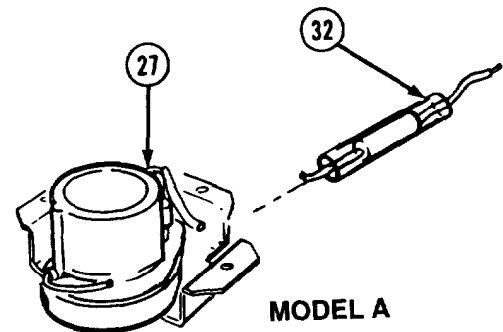
- (15) Remove three screws (26), wire (12), and motor (27).



- (16) Remove screw (28), lockwasher (29), terminal (30), and harness (31) from motor (27).



- (17) Remove resistor (32) from motor (27).



Electrical System Maintenance Instructions (Cont)

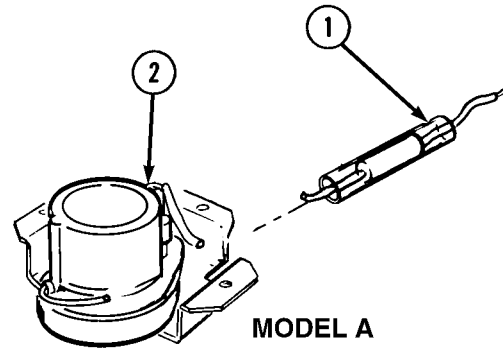
7-55. REMOVABLE WARNING LIGHT REPAIR (MODELS A AND B) (CONT).

b. Assembly.

NOTE

Model A has a replaceable resistor on motor.

- (1) Install resistor (1) on motor (2).

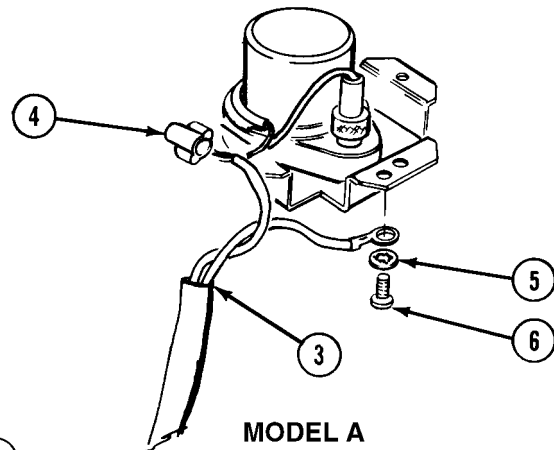


NOTE

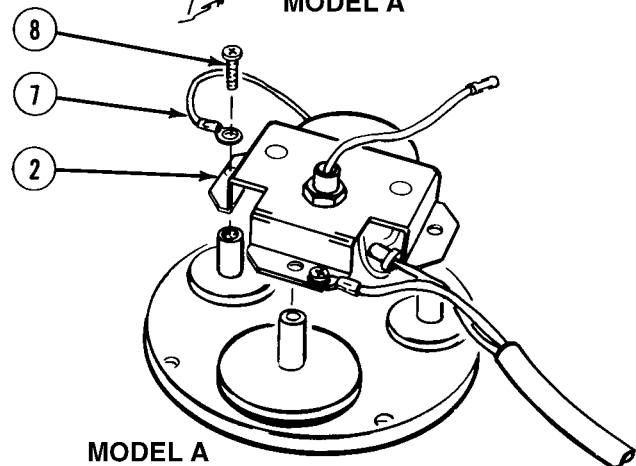
- Model B has a replaceable worm gear on motor while Model A does not.

- Do steps (2) and (3) for Model A.

- (2) Install wire harness (3) with terminal (4), lockwasher (5), and screw (6).



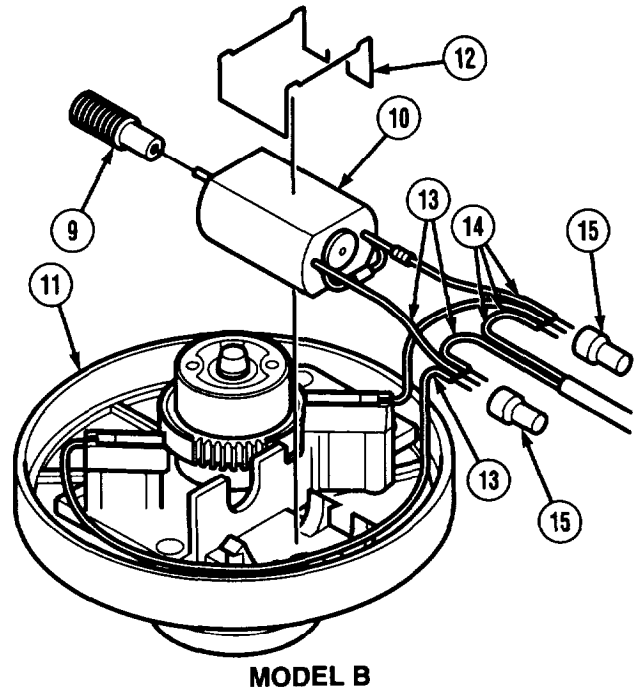
- (3) Install motor (2) with wire (7) and three screws (8).



Electrical System Maintenance Instructions (Cont)

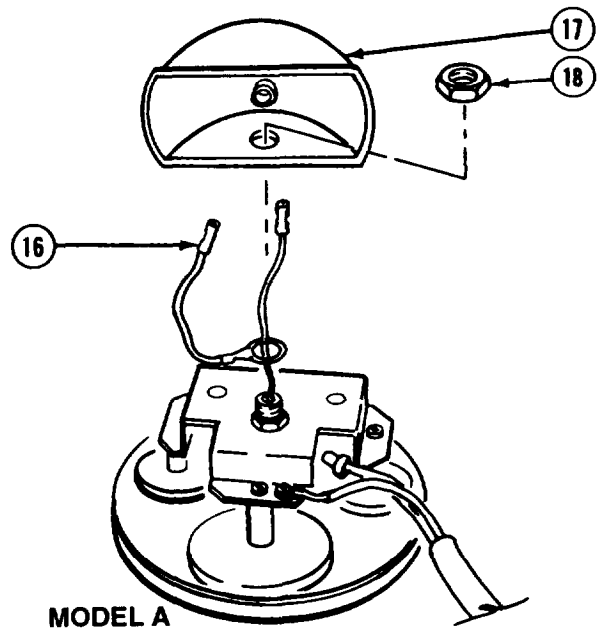
NOTE

- Model B has a replaceable worm gear on motor while Model A does not.
- Do steps (4) thru (6) for Model B.
- (4) Install worm gear (9) on motor (10).
- (5) Install motor (10) in light (11) with retainer (12).
- (6) Connect wires (13) and wires (14) with two connectors (15).



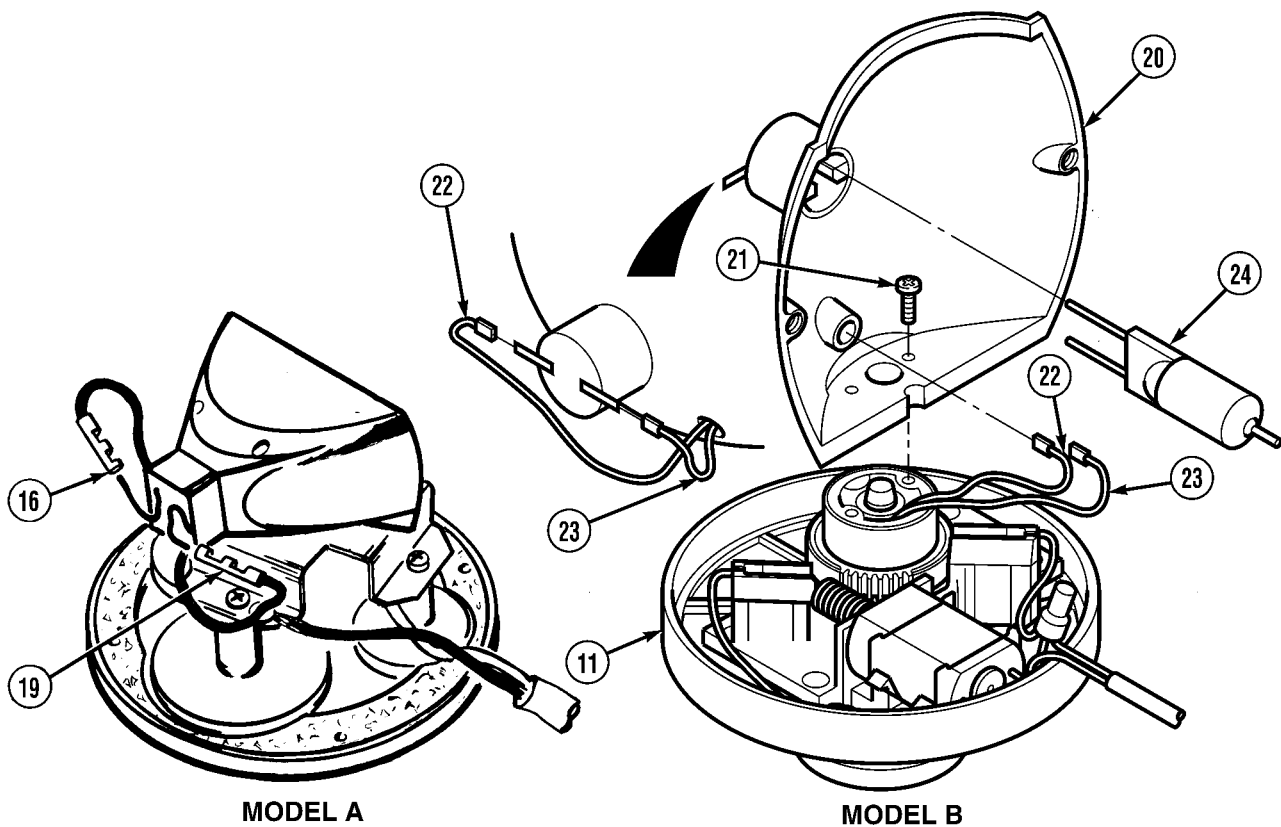
NOTE

- Model A has a sealed unit with a nonreplaceable lamp. Model B has a replaceable lamp.
- Do step (7) for Model A.
- (7) Install wire (16), reflector (17), and nut (18).



Electrical System Maintenance Instructions (Cont)

7-55. REMOVABLE WARNING LIGHT REPAIR (MODELS A AND B) (CONT).

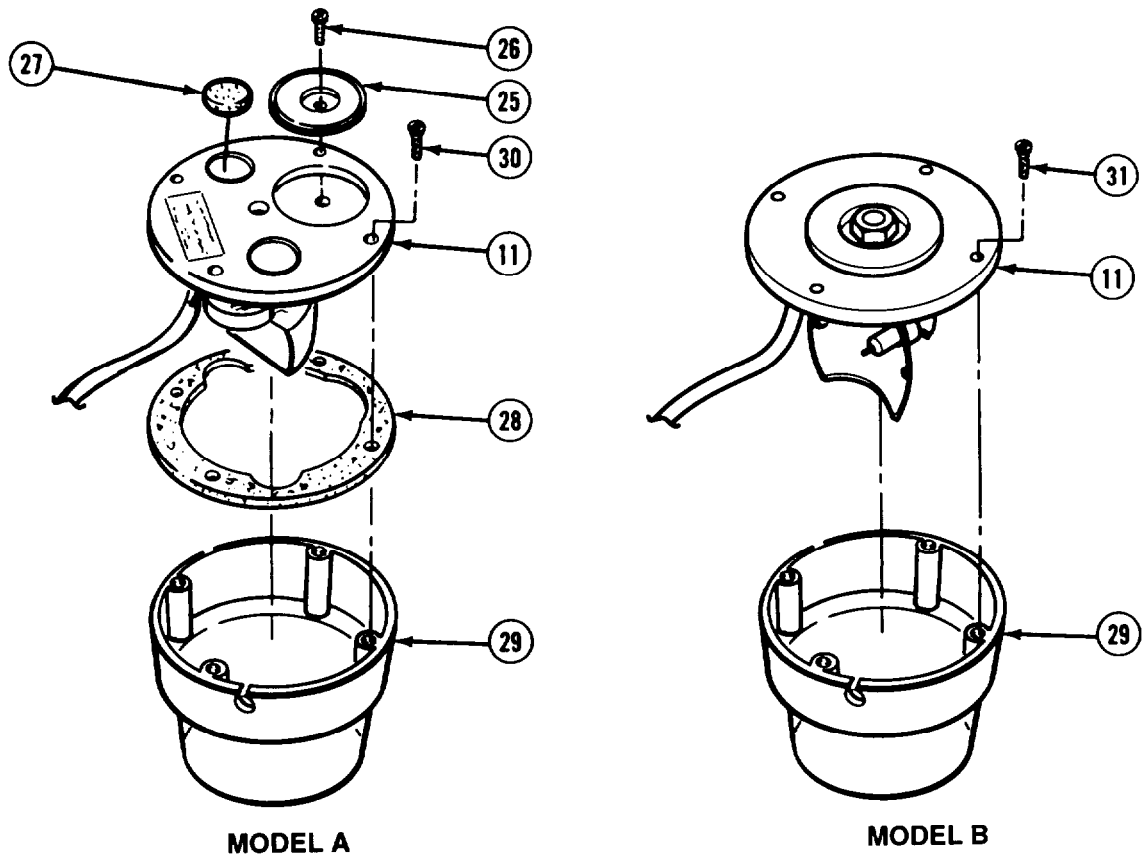


NOTE

- Model A has a sealed unit with a nonreplaceable lamp. Model B has a replaceable lamp.
- Do step (8) for Model A.
- Do steps (9) thru (12) for Model B.

- (8) Connect two wires (16) and (19).
- (9) Install reflector (20) on light (11) with two screws (21).
- (10) Position two wires (22) and (23) through reflector (20).
- (11) Install lamp (24) in reflector (20).
- (12) Connect two wires (22) and (23).

Electrical System Maintenance Instructions (Cont)



NOTE

- Model A has a magnet and two pads on base. Model B has a magnet only.
- Do steps (13) thru (15) for Model A.
- Do step (16) for Model B.

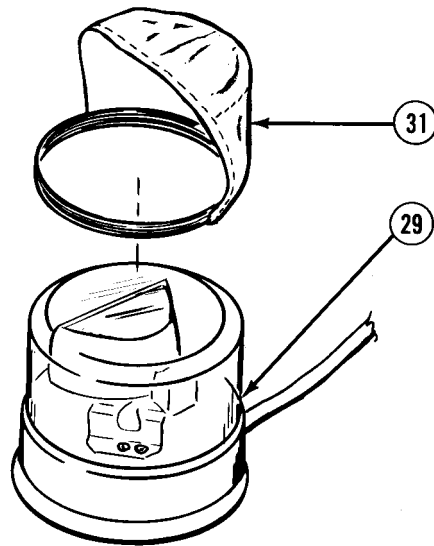
(13) Install magnet (25) with screw (26). _____

WARNING

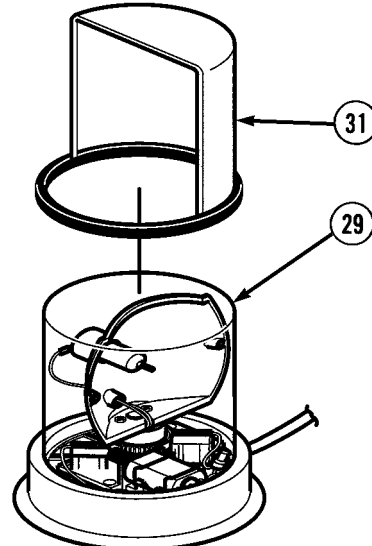
Adhesives, solvents, and sealing compounds can burn easily, can give off harmful vapors, and are harmful to skin and clothing. To avoid injury or death, keep away from open fire and use in well-ventilated area. If adhesive, solvent, or sealing compound gets on skin or clothing, wash immediately with soap and water.

- (14) Apply adhesive to two pads (27) and install.
- (15) Install gasket (28) and dome (29) on light (11) with four screws (30).
- (16) Install dome (29) on light (11) with four screws (31).

Electrical System Maintenance Instructions (Cont)



MODEL A



MODEL B

(17) Install protective shield (31) on dome (29).

c. **Follow-on Maintenance.** Check operation of beacon light (TM 9-2320-279-10).

END OF TASK

Electrical System Maintenance Instructions (Cont)

| | | |
|--|---|------------------------------|
| 7-55.1. REMOVABLE WARNING LIGHT REPAIR (MODEL C). | | |
| This task covers: | | |
| a. Disassembly | c. Follow-on Maintenance | |
| b. Assembly | | |
| INITIAL SETUP | | |
| <i>Models</i> | <i>References</i> | |
| All | None | |
| <i>Test Equipment</i> | <i>Equipment Condition</i> | |
| None | TM or Para | <i>Condition Description</i> |
| <i>Special Tools</i> | Light on clean work surface. | |
| None | <i>Special Environmental Conditions</i> | |
| <i>Supplies</i> | None | |
| Adhesive, No. 4500, Item 1, Appendix C | <i>General Safety Instructions</i> | |
| <i>Personnel Required</i> | None | |
| MOS 63S, Heavy wheel vehicle mechanic | | |

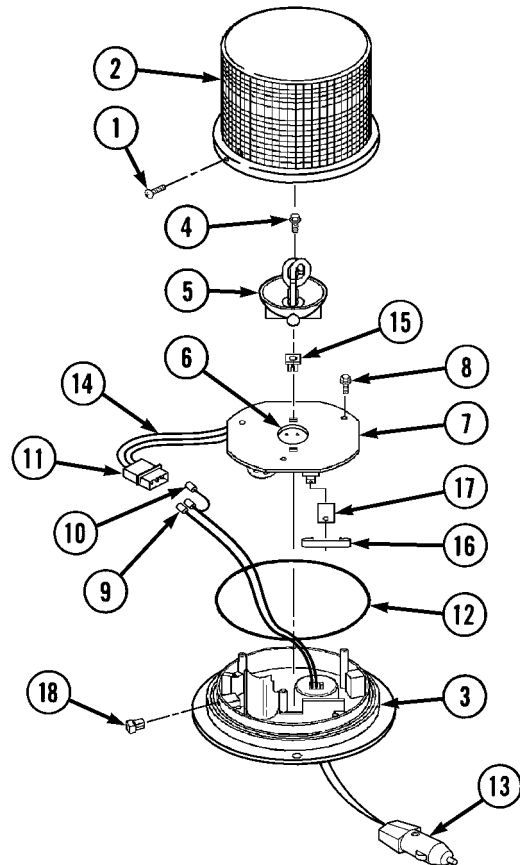
a. Disassembly.

- (1) Remove two screws (1) and lens (2) from warning light assembly (3).
- (2) Remove two screws (4) and flash tube assembly (5) from plug connection (6) and power supply (7).
- (3) Remove three screws (8) from power supply (7).
- (4) Disconnect three sockets (9) and (10) from socket housing (11) and remove power supply (7) and preformed packing (12) from warning light assembly (3).

NOTE

Tag and mark wires prior to removal.

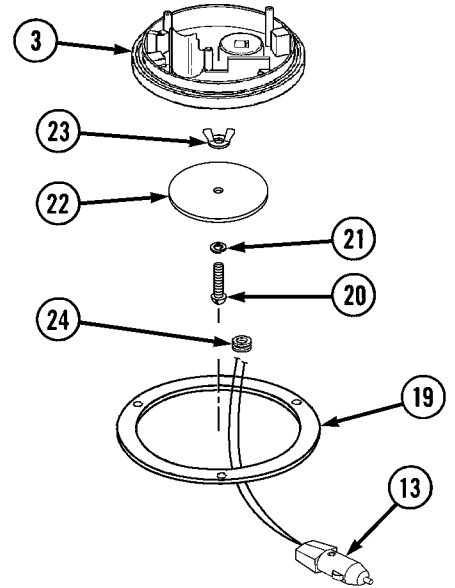
- (5) Remove three sockets (9) and (10) from power cord (13).
- (6) Remove socket housing (11) from wires (14).
- (7) Remove two grommets (15) from power supply (7).
- (8) Remove spring clip (16), insulator (17), and two grommets (18) from warning light assembly (3).



Electrical System Maintenance Instructions (Cont)

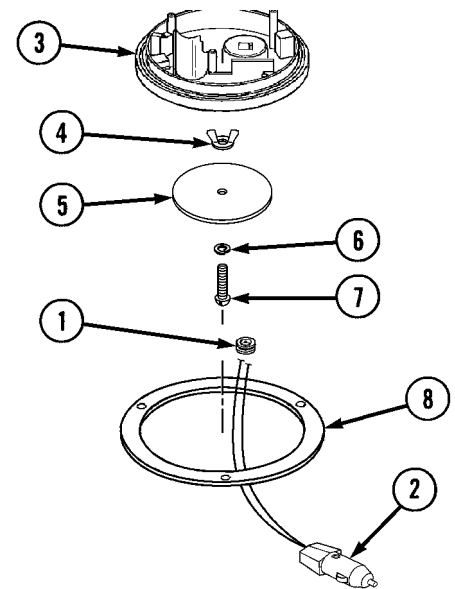
7-55.1. REMOVABLE WARNING LIGHT REPAIR (MODEL C) (CONT).

- (9) Remove gasket (19), screw (20), lockwasher (21), magnet (22), grommet (23), grommet (24), and power cord (13) from warning light assembly (3).
- (10) Remove wire grommet (24) from power cord (13).



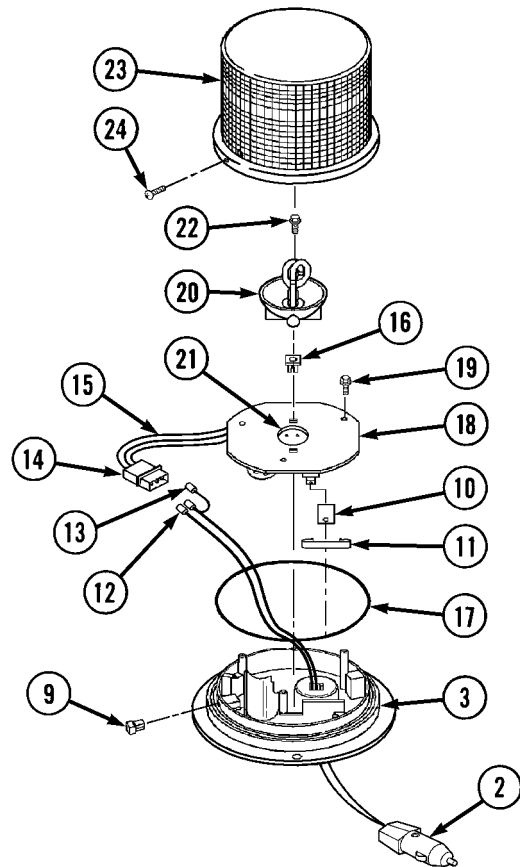
b. Assembly.

- (1) Install grommet (1) on power cord (2) and install power cord in warning light assembly (3).
- (2) Install grommet (4), magnet (5), lockwasher (6), screw (7), and gasket (8) on warning light assembly (3).



Electrical System Maintenance Instructions (Cont)

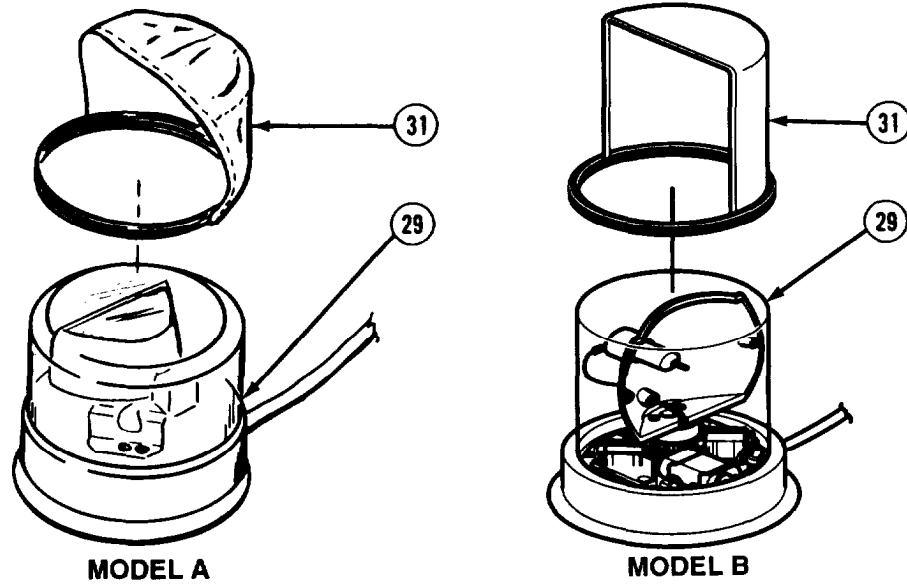
- (3) Install two grommets (9), insulator (10), and spring clip (11), on warning light assembly (3).
- (4) Attach three sockets (12) and (13) to power cord (2).
- (5) Attach socket housing (14) to wires (15).
- (6) Install two grommets (16) and preformed packing (17) on power supply (18).
- (7) Plug three sockets (12) and (13) into socket housing (14) and attach power supply (18) to warning light assembly (3) using three screws (19).
- (8) Attach flash tube assembly (20) to power supply (18) using plug connection (21) and two screws (22).
- (9) Attach lens (23) to warning light assembly (3) using two screws (24).



c. Follow-on Maintenance. Check operation of beacon light (TM 9-2320-279-10).

END OF TASK

Electrical System Maintenance Instructions (Cont)



(17) Install protective shield (31) on dome (29).

c. **Follow-on Maintenance.** Check operation of beacon light (TM 9-2320-279-10).

END OF TASK

Electrical System Maintenance Instructions (Cont)

| | |
|--|--|
| 7-55.1. REMOVABLE WARNING LIGHT REPAIR MODEL C. | |
| This task covers: | |
| a. Disassembly b. Assembly | c. Follow-on Maintenance |
| INITIAL SETUP | |
| <i>Models</i> All | <i>References</i> None |
| <i>Test Equipment</i> None | <i>Equipment Condition</i> TM or Para |
| <i>Special Tools</i> None | <i>Condition Description</i> Light on clean work surface. |
| <i>Supplies</i> Adhesive, No. 4500, Item 1, Appendix C | <i>Special Environmental Conditions</i> None |
| <i>Personnel Required</i> MOS 63S, Heavy wheel vehicle mechanic | <i>General Safety Instructions</i> None |

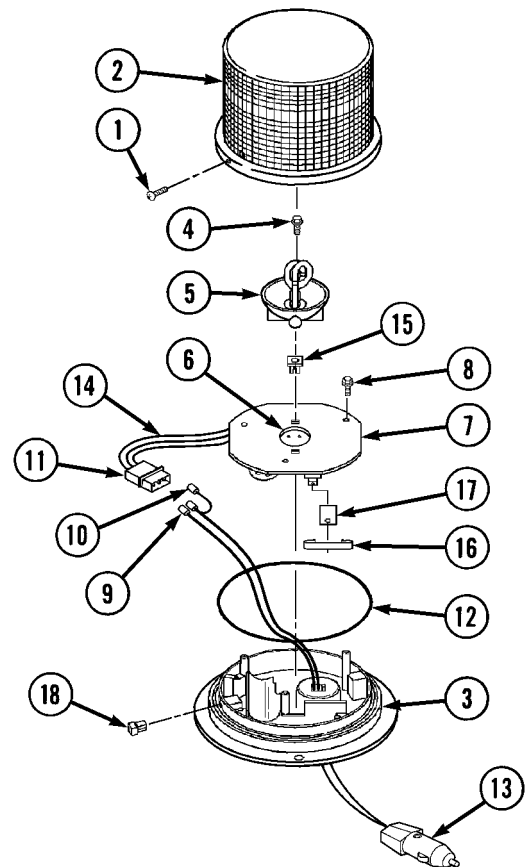
a. *Disassembly.*

- (1) Remove two screws (1) and lens (2) from warning light assembly (3).
- (2) Remove two screws (4) and flash tube assembly (5) from plug connection (6) and power supply (7).
- (3) Remove three screws (8) from power supply (7).
- (4) Disconnect three sockets (9) and (10) from socket housing (11) and remove power supply (7) and preformed packing (12) from warning light assembly (3).

NOTE

Tag and mark wires prior to removal.

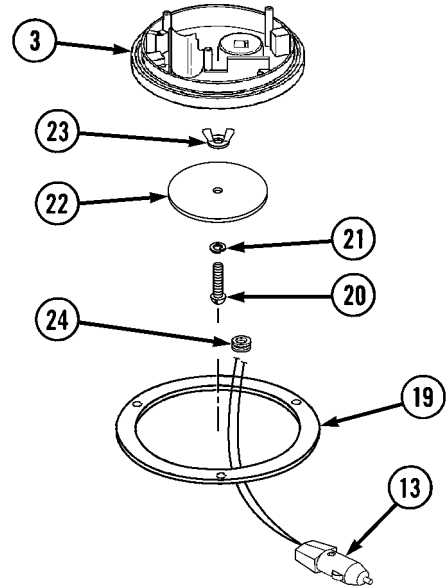
- (5) Remove three sockets (9) and (10) from power cord (13).
- (6) Remove socket housing (11) from wires (14).
- (7) Remove two grommets (15) from power supply (7).
- (8) Remove spring clip (16), insulator (17), and two grommets (18) from warning light assembly (3).



Electrical System Maintenance Instructions (Cont)

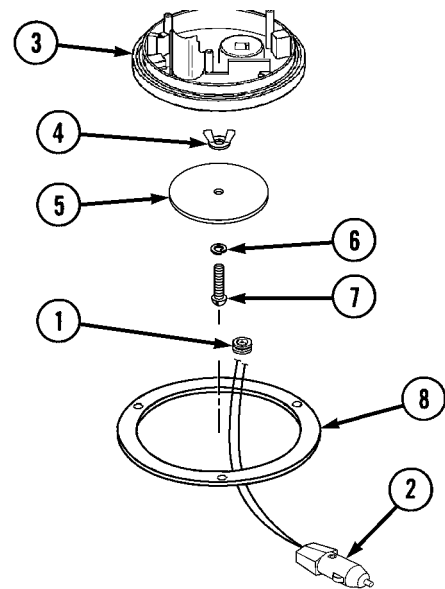
7-55.1. REMOVABLE WARNING LIGHT REPAIR MODEL C (CONT).

- (9) Remove gasket (19), screw (20), lockwasher (21), magnet (22), grommet (23), grommet (24), and power cord (13) from warning light assembly (3).
- (10) Remove wire grommet (24) from power cord (13).



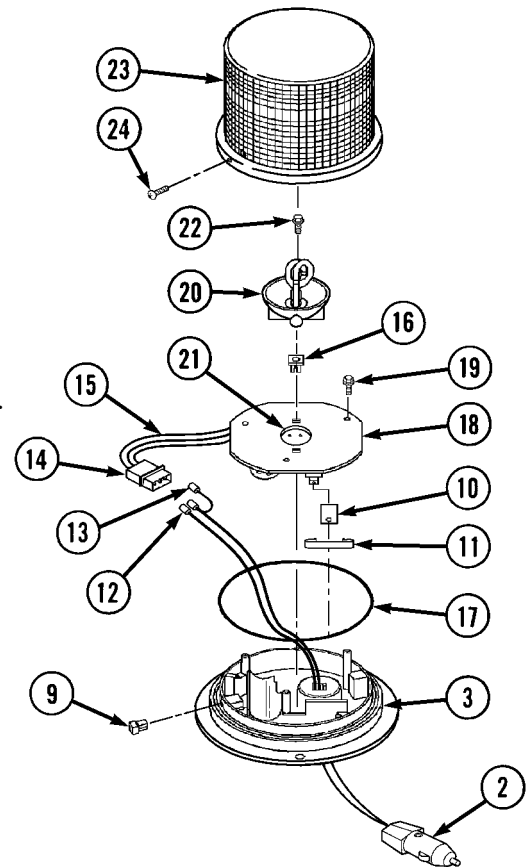
b. Assembly.

- (1) Install grommet (1) on power cord (2) and install power cord in warning light assembly (3).
- (2) Install grommet (4), magnet (5), lockwasher (6), screw (7), and gasket (8) on warning light assembly (3).



Electrical System Maintenance Instructions (Cont)

- (3) Install two grommets (9), insulator (10), and spring clip (11), on warning light assembly (3).
- (4) Attach three sockets (12) and (13) to power cord (2).
- (5) Attach socket housing (14) to wires (15).
- (6) Install two grommets (16) and preformed packing (17) on power supply (18).
- (7) Plug three sockets (12) and (13) into socket housing (14) and attach power supply (18) to warning light assembly (3) using three screws (19).
- (8) Attach flash tube assembly (20) to power supply (18) using plug connection (21) and two screws (22).
- (9) Attach lens (23) to warning light assembly (3) using two screws (24).



c. **Follow-on Maintenance.** Check operation of beacon light (TM 9-2320-279-10).

END OF TASK

Electrical System Maintenance Instructions (Cont)

7-56. OPTIC RIBBON ASSEMBLY REMOVAL/INSTALLATION.

This task covers:

- a. Removal
- b. Installation
- c. Follow-on Maintenance

INITIAL SETUP

Models

All

Test Equipment

None

Special Tools

None

Supplies

Tags, identification, Item 48, Appendix C

Personnel Required

MOS 63S, Heavy wheel vehicle mechanic

References

None

Equipment Condition

Tm or Para

Para 7-91

Condition Description

Batteries disconnected.

Special Environmental Conditions

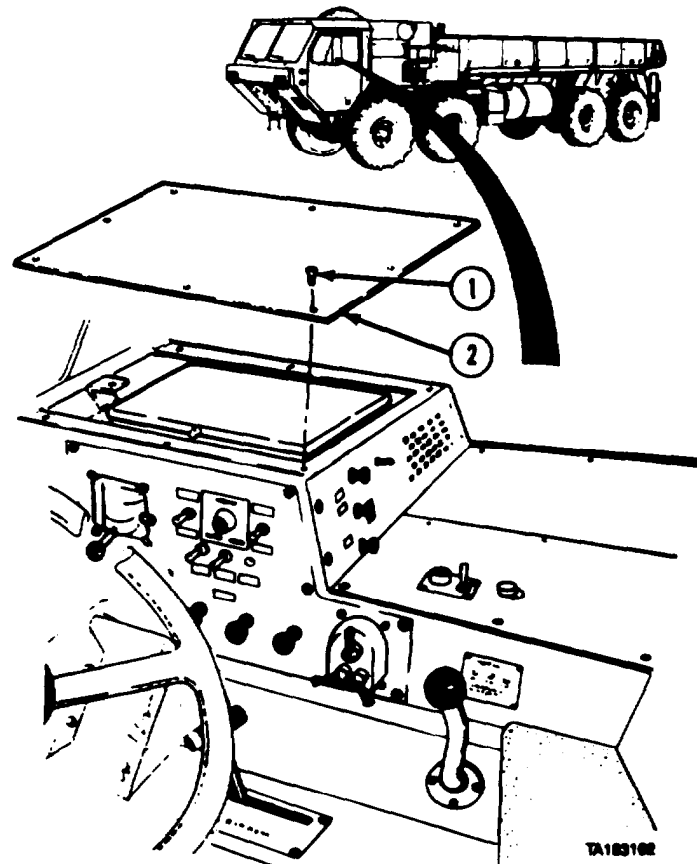
None

General Safety Instructions

None

a. Removal.

- (1) Remove eight screws (1) and heater compartment cover (2).



Electrical System Maintenance Instructions (Cont)

NOTE

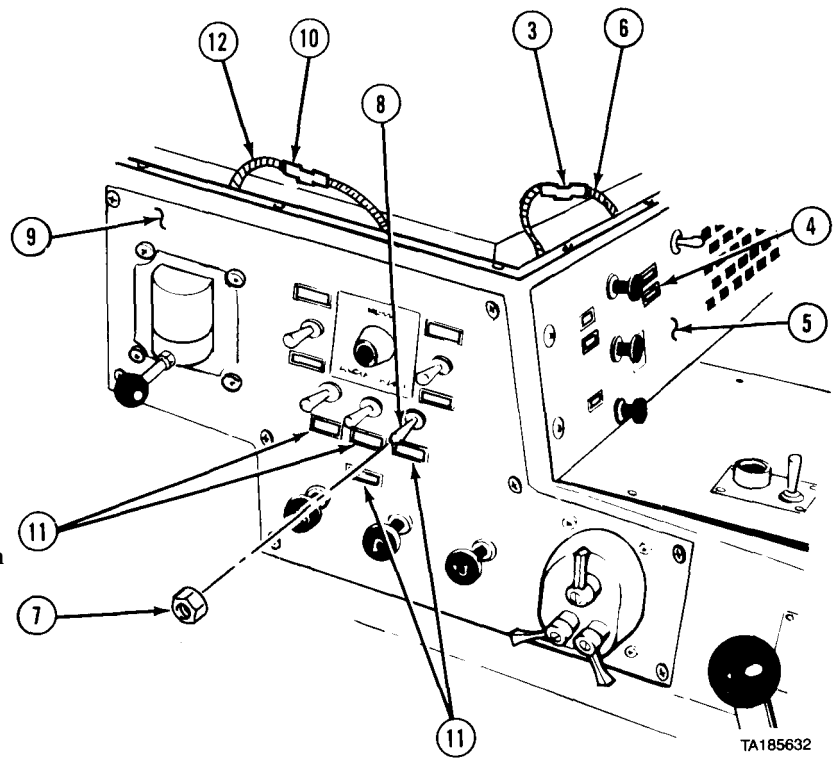
Mark panel openings for position of identification markers.

- (2) Remove five identification markers (3) from lens (4) on heater control panel (5) and move optic ribbon (6) aside.

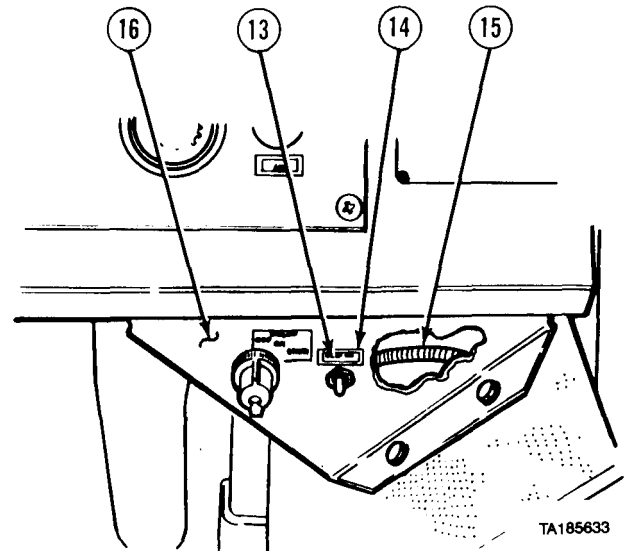
NOTE

Tag and mark switches before removing.

- (3) Remove three nuts (7) and switches (8) from side panel (9).
- (4) Remove four identification markers (10) from lens (11) on side panel (9) and move optic ribbon (12) aside.



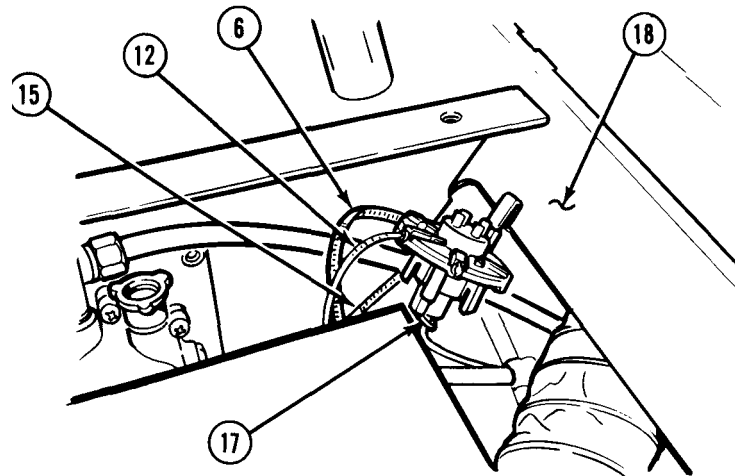
- (5) Remove ENGINE STOP identification marker (13) from lens (14) and remove optic ribbon (15) from bracket (16).



Electrical System Maintenance Instructions (Cont)

7-56. OPTIC RIBBON ASSEMBLY REMOVAL/INSTALLATION (CONT).

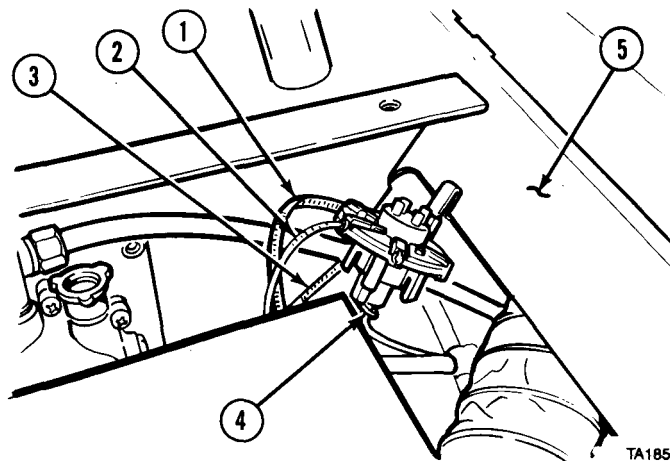
- (6) Remove light source (17) from instrument panel (18).
- (7) Unplug and remove three optic ribbons (6, 12, and 15) from light source (17).



TA185634

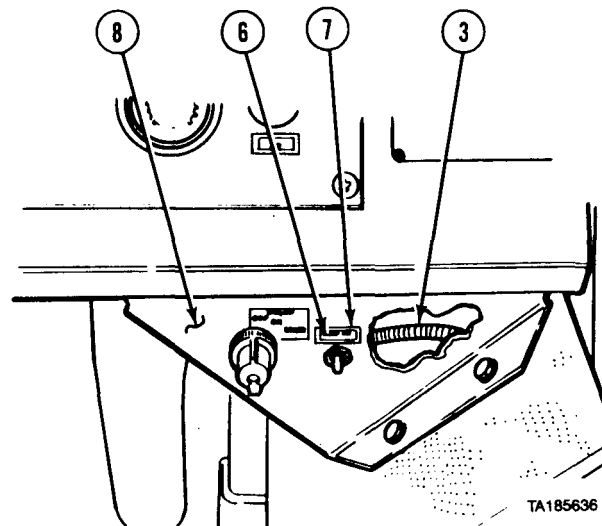
b. Installation.

- (1) Plug three optic ribbons (1, 2, and 3) into light source (4).
- (2) Install light source (4) on instrument panel (5).



TA185635

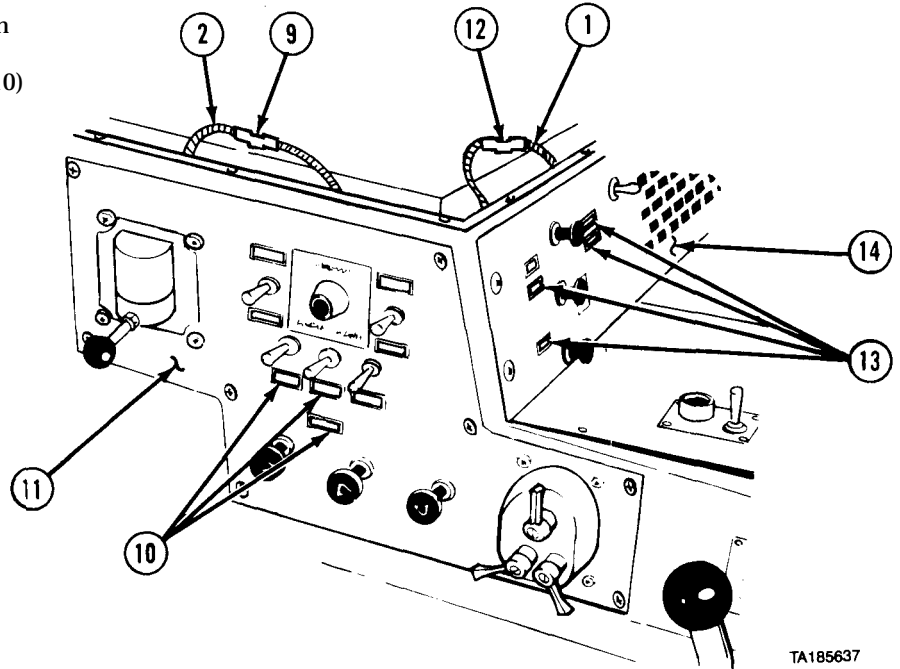
- (3) Install ENGINE STOP identification marker (6) with optic ribbon (3) in lens (7) and bracket (8).



TA185636

Electrical System Maintenance Instructions (Cont)

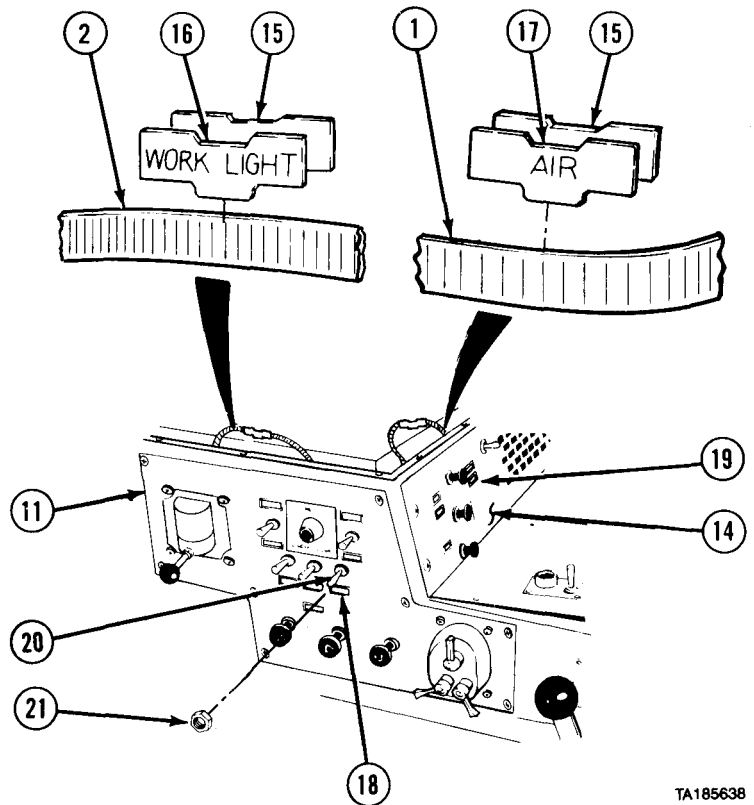
- (4) Install three identification markers (9) with optic ribbon (2) in three lens (10) on side panel (11).
- (5) Install four identification markers (12) with optic ribbon (1) in lens (13) on heater control panel (14).



TA185637

WORK LIGHT identification marker is installed on M983 and M984 only. AIR and WORK LIGHT identification markers must be installed on new optic ribbons.

- (6) Peel backup plate (15) from identification markers (16 and 17).
- (7) Install backup plate (15) and identification marker (16) on optic ribbon (2).
- (8) Install backup plate (15) and identification marker (17) on optic ribbon (1).
- (9) Install identification marker (16) with optic ribbon (2) in lens (18) on side panel (11).
- (10) Install identification marker (17) with optic ribbon (1) in lens (19) on heater control panel (14).
- (11) Install three switches (20) with three nuts (21).



TA185638

Electrical System Maintenance Instructions (Cont)

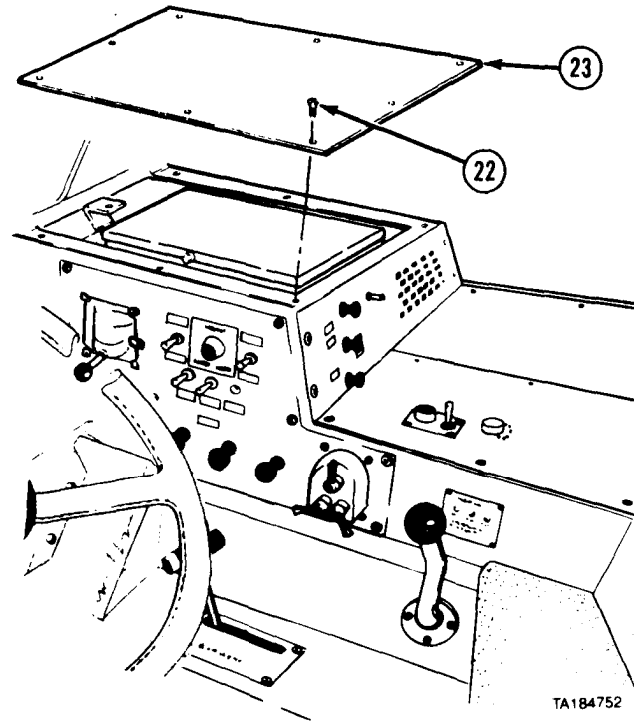
7-56. OPTIC RIBBON ASSEMBLY REMOVAL/INSTALLATION (CONT).

(12) Install heater compartment cover (23) with eight screws (22).

c. *Follow-on Maintenance.*

- (1) Connect batteries (para 7-91).
- (2) Check operation of optic ribbon and placement of identification markers (TM 9-2320-279-10).

END OF TASK



7-57. HEADLIGHT ADJUSTMENT.

This task covers:

- a. Headlight Aim Check
- b. Headlight Adjustment
- c. Follow-on Maintenance

INITIAL SETUP

Models

All

Test Equipment

None

Special Tools

None

Supplies

Chalk, Item 8, Appendix C

Personnel Required

MOS 63S, Heavy wheel vehicle mechanic

References

None

Equipment Condition

| | | |
|-------------------|----------------------|--------------------|
| <i>TM or Para</i> | <i>Condition</i> | <i>Description</i> |
| TM 9-2320-279-10 | Check tire pressure. | |

Special Environmental Conditions

None

General Safety Instructions

None

Electrical System Maintenance Instructions (Cont)

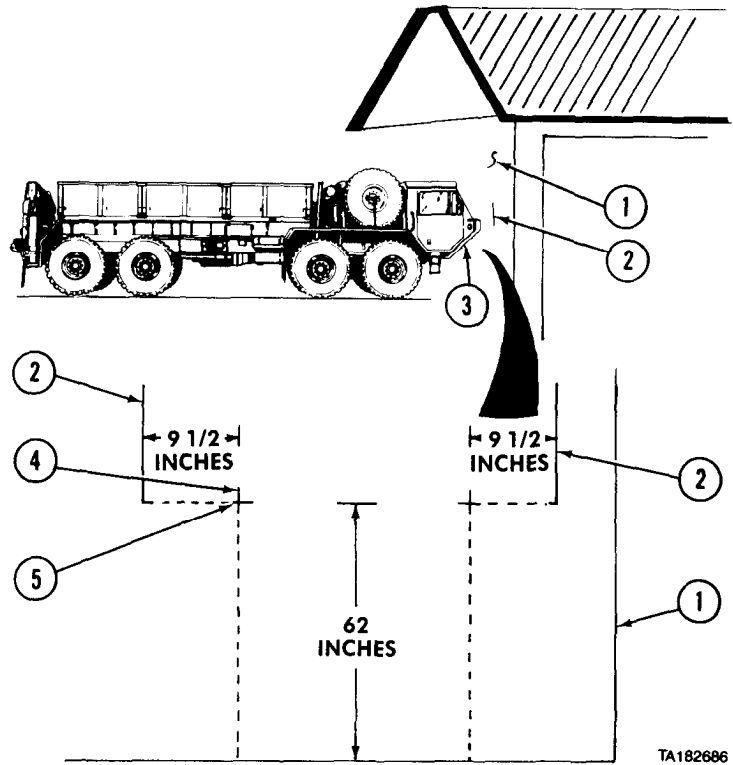
a. Headlight Aim Check.

- (1) Park vehicle 18 in. (46 cm) from flat vertical surface (1). Set parking brakes and shut off engine (TM 9-2320-279-10).

NOTE

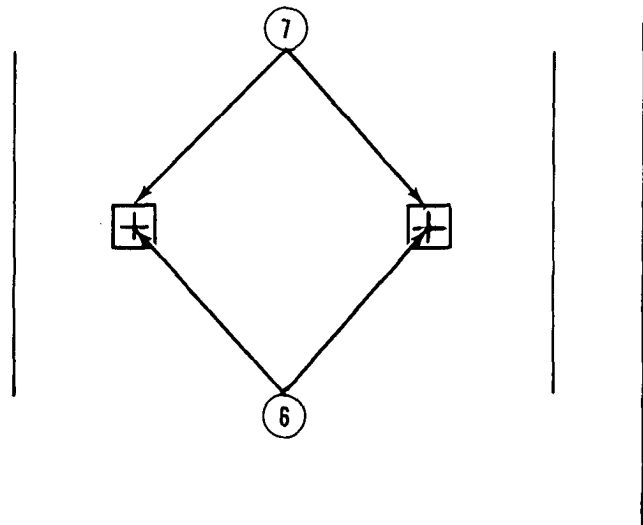
Vehicle should be empty before checking aim of headlights.

- (2) Using chalk, draw vertical line (2) on flat vertical surface (1) from each end of skid plate (3).
- (3) Measure in 9 1/2 in. (24 cm) from each vertical chalk line (2) and draw small vertical chalk line (4).
- (4) Measure up 62 in. (157.5 cm) from ground and draw horizontal chalk line (5) of step making a cross.



TA182686

- (5) Measure out 4 in. (10 cm) from center of each cross (6) in four directions to make an 8-in. (20 cm) square (7).
- (6) Turn headlights on low beam (TM 9-2320-279-10).

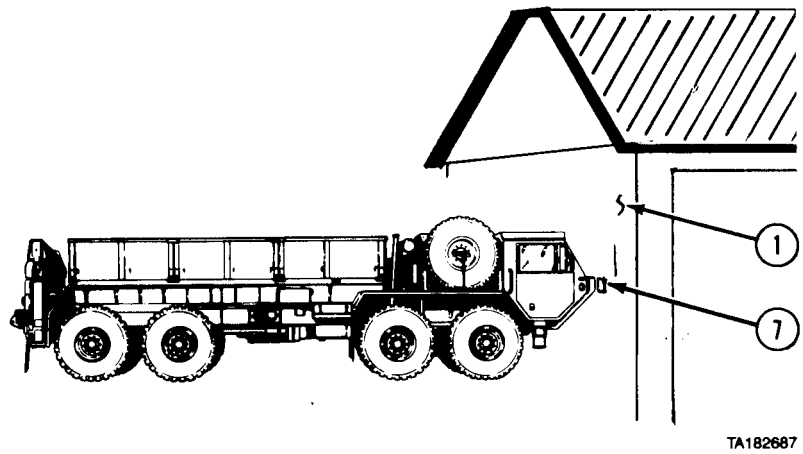


TA182686

Electrical System Maintenance Instructions (Cont)

7-57. HEADLIGHT ADJUSTMENT (CONT).

(7) Observe spots of light headlights make on surface (1). If spots of light are within squares (7), alignment is correct. If not, adjust headlights.

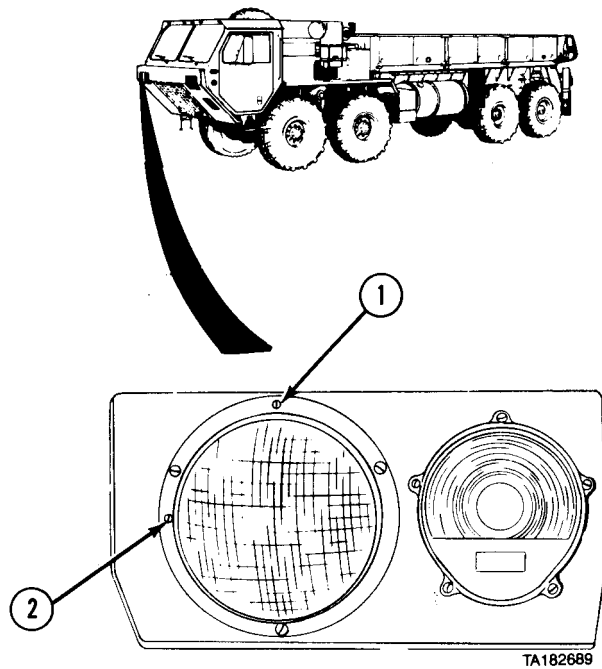


b. Headlight Adjustment.

- (1) Adjust screw (1) to move headlight spot on vertical surface up or down.
- (2) Adjust screw (2) to move headlight spot on vertical surface right or left.

c. Follow-on Maintenance. None.

END OF TASK



Electrical System Maintenance Instructions (Cont)

7-58. HEADLIGHT REMOVAL/INSTALLATION.

This task covers:

- a. Removal
- b. Installation
- c. Follow-on Maintenance

INITIAL SETUP

Models

All

Test Equipment

None

Special Tools

None

Supplies

Tags, identification, Item 48, Appendix C

Personnel Required

MOS 63S, Heavy wheel vehicle mechanic

References

None

Equipment Condition

TM or Para

Condition Description

TM 9-2320-279-10 Headlight switch off.
Para 7-91 Batteries disconnected.

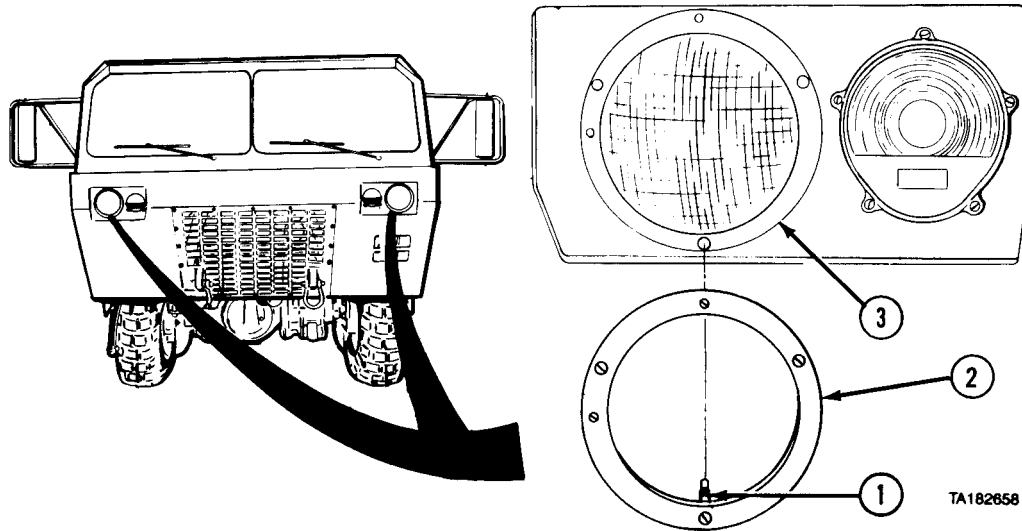
Special Environmental Conditions

None

General Safety Instructions

None

a. Removal.



- (1) Loosen three captive screws (1) from headlight retaining ring (2) and mount (3).
- (2) Remove headlight retaining ring (2).

Electrical System Maintenance Instructions (Cont)

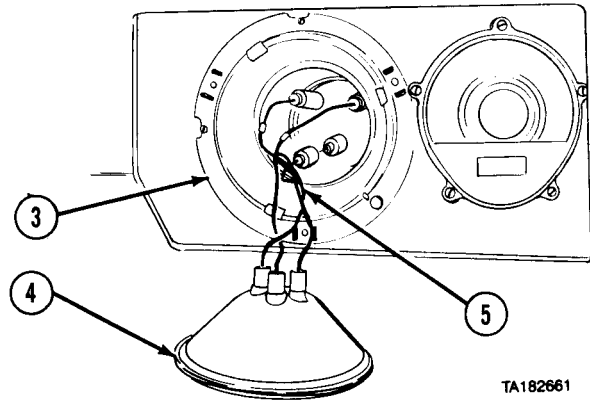
7-58. HEADLIGHT REMOVAL/INSTALLATION (CONT).

(3) Remove headlight (4) from mount (3).

NOTE

Tag and mark wires before disconnecting.

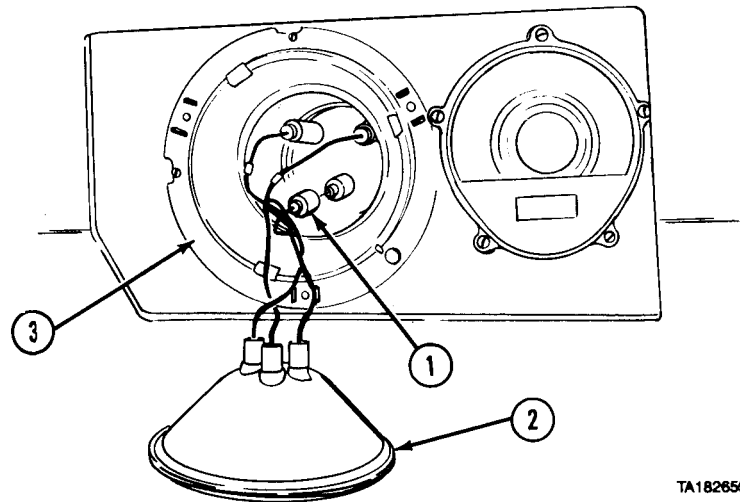
(4) Disconnect three wires (5).



b. Installation.

(1) Connect three wires (1).

(2) Install headlight (2) in mount (3).



(3) Install headlight retaining ring (4) on mount (3).

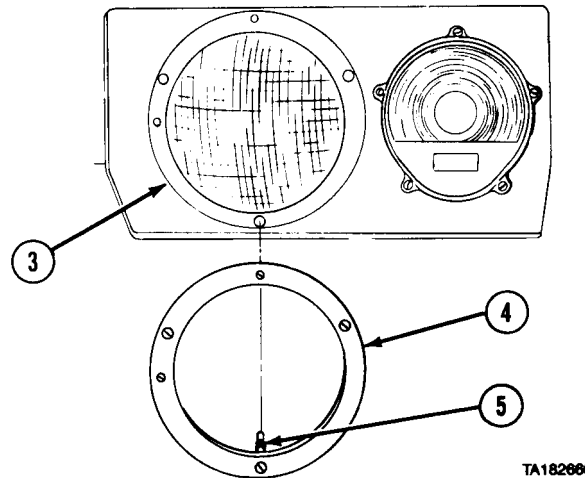
(4) Tighten three captive screws (5) to fasten headlight retaining ring (4) to mount (3).

c. Follow-on Maintenance.

(1) Connect batteries (para 7-91).

(2) Check operation of headlights (TM 9-2320-279-10).

(3) Adjust headlights (para 7-57).



END OF TASK

Electrical System Maintenance Instructions (Cont)

7-59. HEADLIGHT ASSEMBLY REMOVAL/INSTALLATION.

This task covers:

- a. Removal
- b. Installation
- c. Follow-on Maintenance

INITIAL SETUP

Models
All

Test Equipment
None

Special Tools
None

Supplies
Tags, identification, Item 48, Appendix C

Personnel Required
MOS 63S, Heavy wheel vehicle mechanic

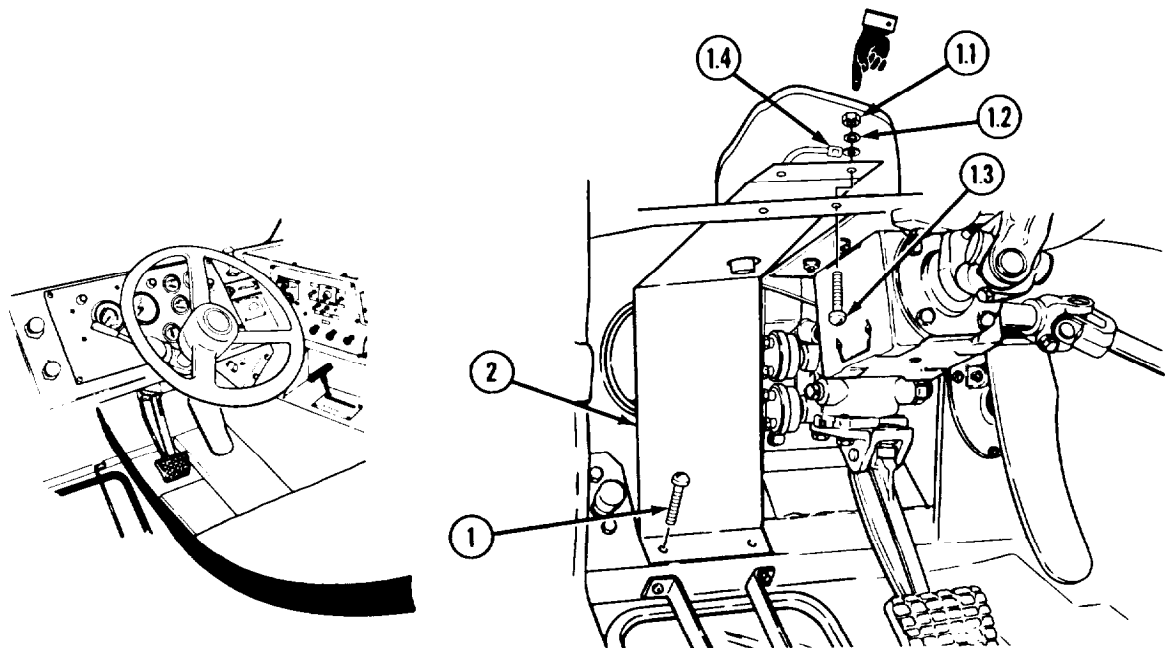
References
None

Equipment Condition
TM or Para *Condition Description*
Para 7-58 Headlight removed.

Special Environmental Conditions
None

General Safety Instructions
None

a. Removal.



NOTE

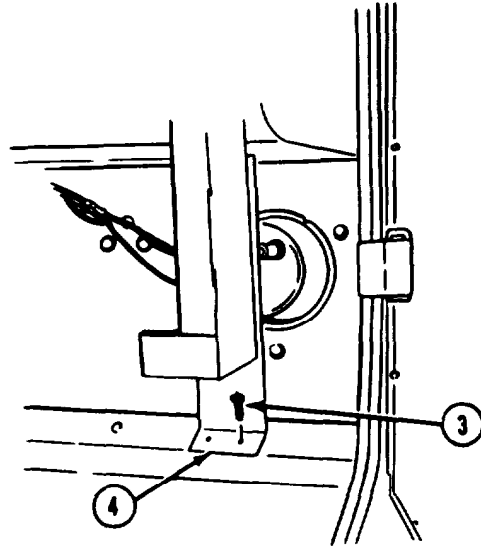
If turn signal flasher relay is not mounted to guard, there are four screws and no nut or lockwasher.

- (1) Remove three screws (1), nut (1.1), lockwasher (1.21), screw (1.31), ground wire (1.4), and wide guard (2) from driver side.

Electrical System Maintenance Instructions (Cont)

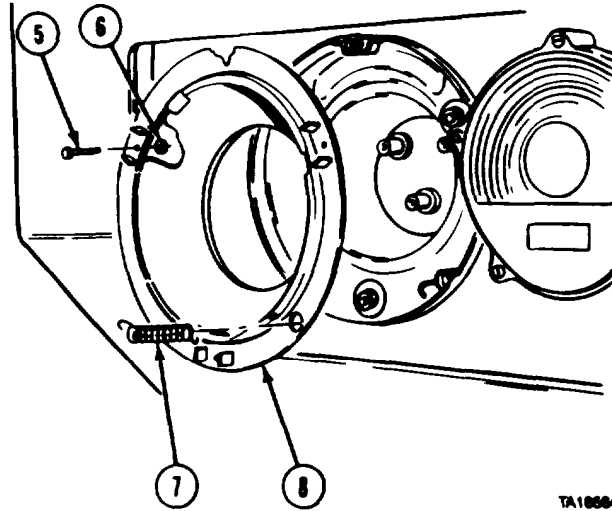
7-59. HEADLIGHT ASSEMBLY REMOVAL/INSTALLATION (CONT).

- (2) Remove four screws (3) and narrow guard (4) from passenger side.



TA102067

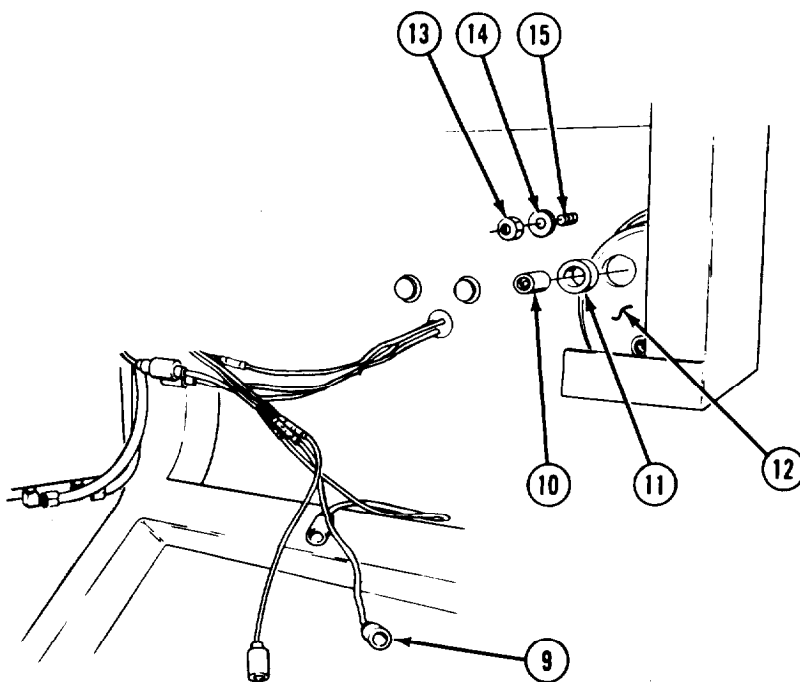
- (3) Remove three screws (5) and nuts (6).
- (4) Remove spring (7) and ring assembly (8).



TA106040

Electrical System Maintenance Instructions (Cont)

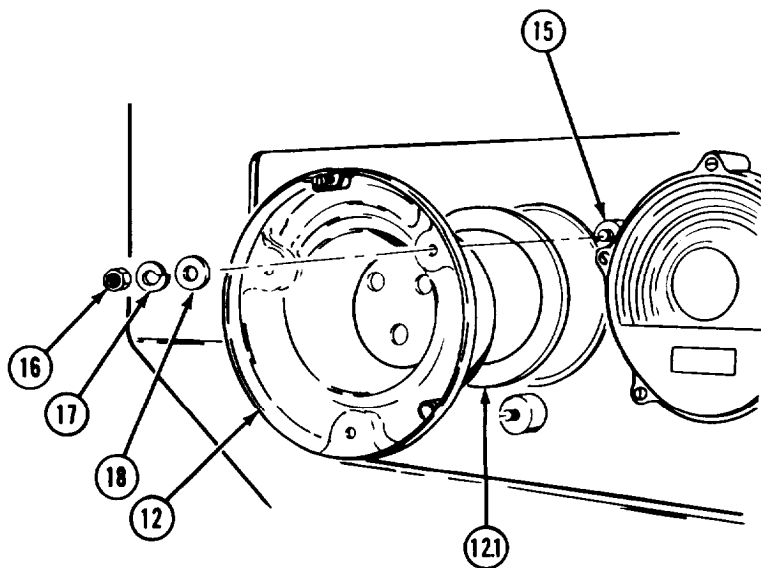
- (5) Disconnect three plug-in connectors (9) from connectors (10) inside cab.
- (6) Remove three connectors (10) and grommets (11) from housing assembly (12).
- (7) Remove three nuts (13) and washers (14) from mounts (15) inside cab.



NOTE

There are two kinds of sealing materials for the headlight. One is a channel type seal while the other is a round gasket.

- (8) Remove housing assembly (12) and gasket or seal (12.1).
- (9) Remove three nuts (16), lockwashers (17), and washers (18) from three mounts (15).
- (10) Remove three mounts (15) from housing (12).



Electrical System Maintenance Instructions (Cont)

7-59. HEADLIGHT ASSEMBLY REMOVAL/INSTALLATION (CONT).

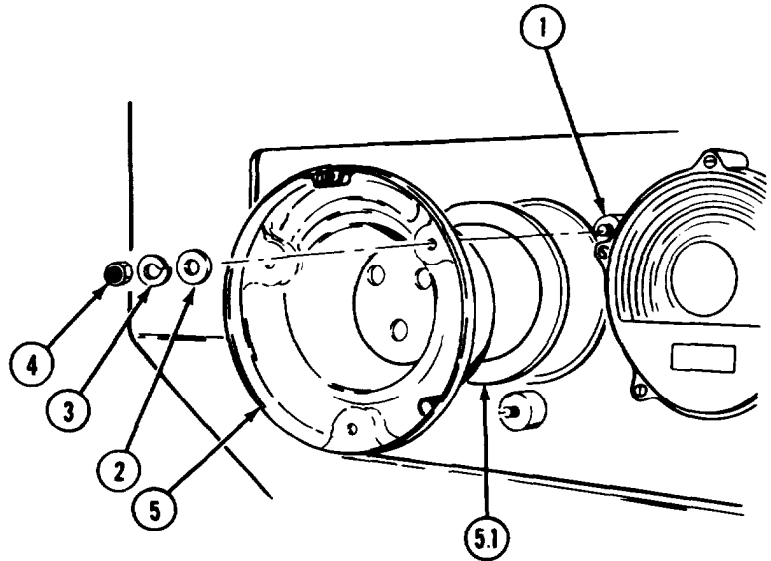
b. Installation.

- (1) Install three mounts (1) with three washers (2), lockwashers (3), and nuts (4) on housing assembly (5).

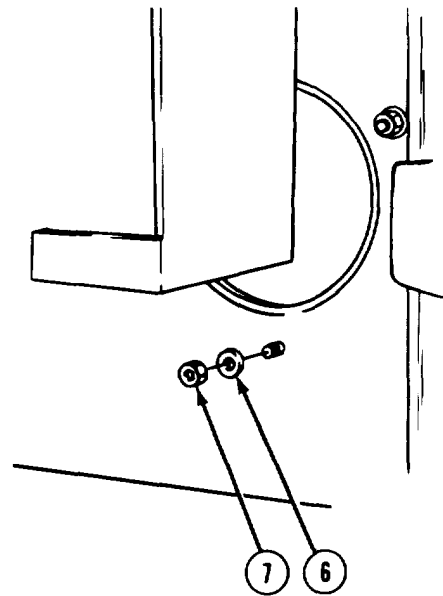
NOTE

There are two kinds of sealing materials for the headlight. One is a channel type seal while the other is a round gasket.

- (1.1) Install gasket or seal (5.1) and housing assembly (5).

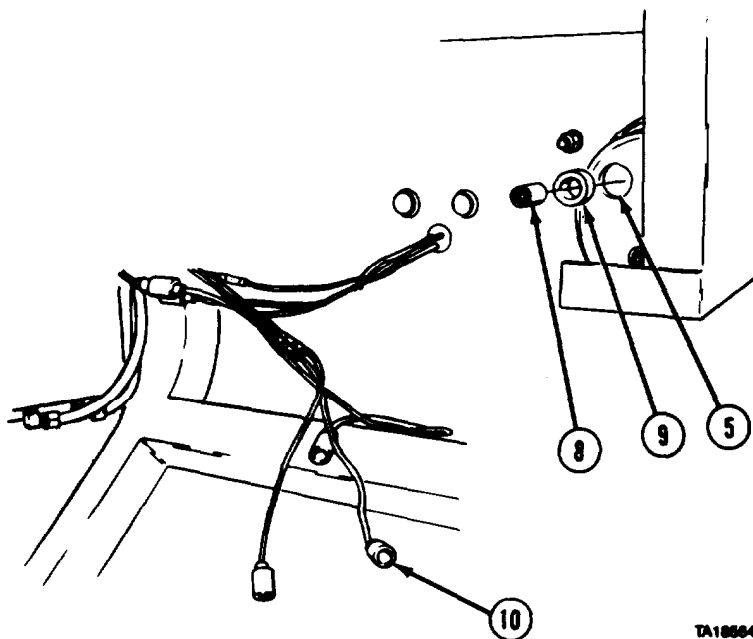


- (2) Install three washers (6) and nuts (7) inside cab.



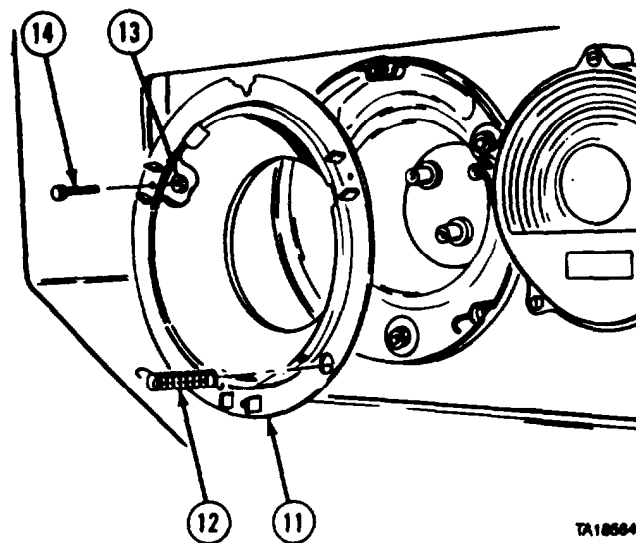
Electrical System Maintenance Instructions (Cont)

- (3) *Install* three connectors (8) and grommets (9) in housing assembly (6) inside cab.
- (4) *Connect* three plug-in connectors (10) to connectors (8).



TA185645

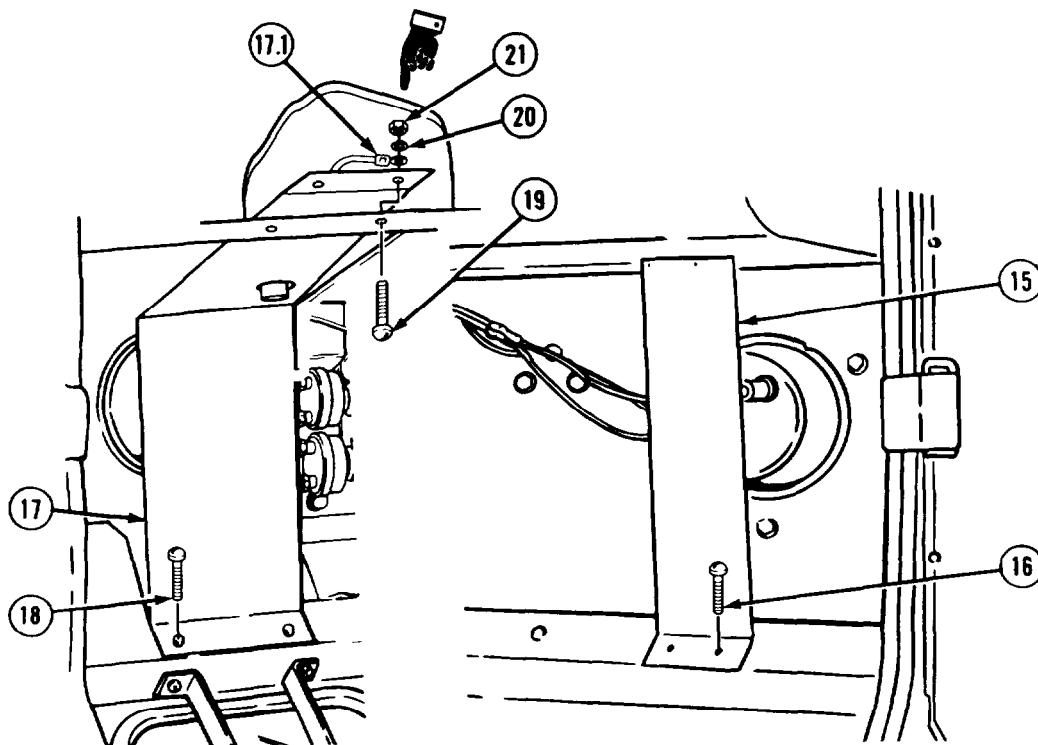
- (5) *Install* ring assembly (11) with spring (12), three nuts (13), and screws (14).



TA185646

Electrical System Maintenance Instructions (Cont)

7-59. HEADLIGHT ASSEMBLY REMOVAL/INSTALLATION (CONT).



(6) Install narrow guard (15) on passenger side with four screws (16).

NOTE

- If the turn signal flasher relay is not mounted to guard, there are four screws and no nut or lockwasher.
- If turn signal flasher relay is mounted to guard, screw, lockwasher, and nut also attach flasher relay and ground wire.

(7) Install wide guard (17) and ground wire (17.1) on driver side with three screws (18), screw (19), lockwasher (20), and nut (21).

c. **Follow-on Maintenance.** Install headlight (para 7-58).

END OF TASK

Electrical System Maintenance Instructions (Cont)

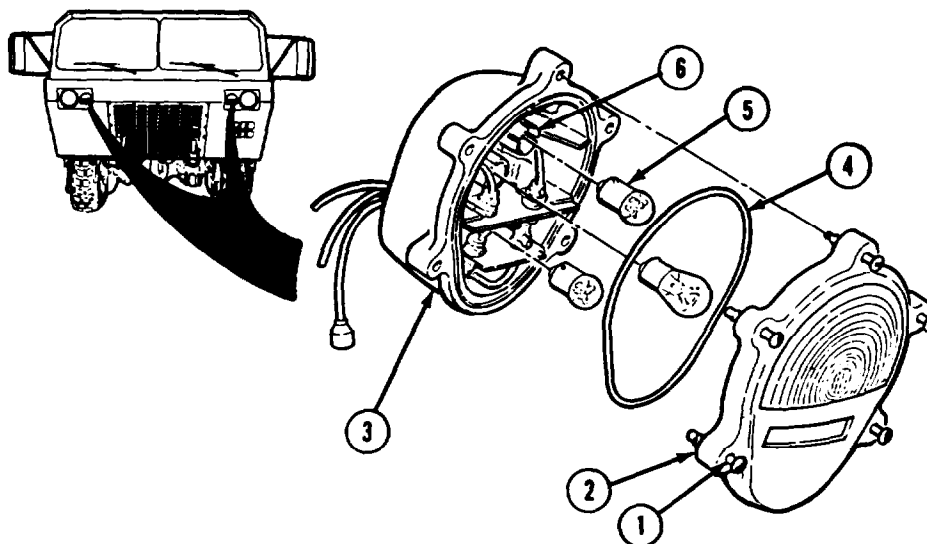
| | | |
|--|---|------------------------------|
| 7-60. FRONT AND REAR COMPOSITE LIGHT LAMP REMOVAL/INSTALLATION. | | |
| This task covers: | | |
| a. Removal | c. Follow-on Maintenance | |
| b. Installation | | |
| INITIAL SETUP | | |
| <i>Models</i> | <i>References</i> | |
| All | None | |
| <i>Test Equipment</i> | <i>Equipment Condition</i> | |
| None | <i>TM or Para</i> | <i>condition Description</i> |
| <i>Special Tools</i> | Para 7-91 | Batteries disconnected. |
| None | <i>Special Environmental Conditions</i> | |
| <i>Supplies</i> | None | |
| None | <i>General Safety Instructions</i> | |
| <i>Personnel Required</i> | None | |
| MOS 63S, Heavy wheel vehicle mechanic | | |



Electrical System Maintenance Instructions (Cont)

7-60. FRONT AND REAR COMPOSITE LIGHT LAMP REMOVAL/INSTALLATION (CONT).

a. Removal.



NOTE

- Rear door assembly held by six screws.
- There are two types of front and rear composite lights. Model A has a larger lens than Model B. Removal and installation procedures are the same for both. Not all parts are interchangeable.
- Model B front composite light has a printed circuit board for the blackout marker.
- Model B rear composite light has a printed circuit board for the blackout marker and the stop lamp.

- (1) Loosen five screws (1) that fasten door assembly (2) to composite light body (3).
- (2) Remove door assembly (2) and gasket (4) from composite light body (3).
- (3) Remove lamp (5) from socket (6).

b. Installation.

- (1) Install lamp (5) in socket (6).
- (2) Install gasket (4).

NOTE

Rear door assembly held by six screws.

- (3) Install door assembly (2) on composite light body (3). Tighten five screws (1).

c. Follow-on Maintenance.

- (1) Connect batteries (para 7-91).
- (2) Check operation of composite light (TM 9-2320-279-10).

END OF TASK

Electrical System Maintenance instructions (Cont)

7-61. FRONT COMPOSITE LIGHT ASSEMBLY REMOVAL/INSTALLATION.

This task covers:

- a. Removal
- b. Installation
- c. Follow-on Maintenance

INITIAL SETUP

Models

All

References

None

Test Equipment

None

Equipment Condition

TM or Para

Condition Description

Special Tools

None

Para 7-91

Batteries disconnected.

Para 11-10

Brake treadle valve removed. (Only when removing left front composite light.)

Supplies

Tags, identification, Item 48, Appendix C

Personnel Required

MOS 63S, Heavy wheel vehicle mechanic (2)

Special Environmental Conditions

None

General Safety Instructions

None

Electrical System Maintenance Instructions (Cont)

7-61. FRONT COMPOSITE LIGHT ASSEMBLY REMOVAL/INSTALLATION (CONT).

NOTE

- There are three types of front and rear composite lights. Model A has a larger lens than Model B. Model C is an LED composite light. Removal and installation procedures are the same for Model A and Model B. Not all parts are interchangeable.
- Model B front composite light has a printed circuit board for the blackout marker.
- Model C front composite light is an LED with a ground wire pigtail.

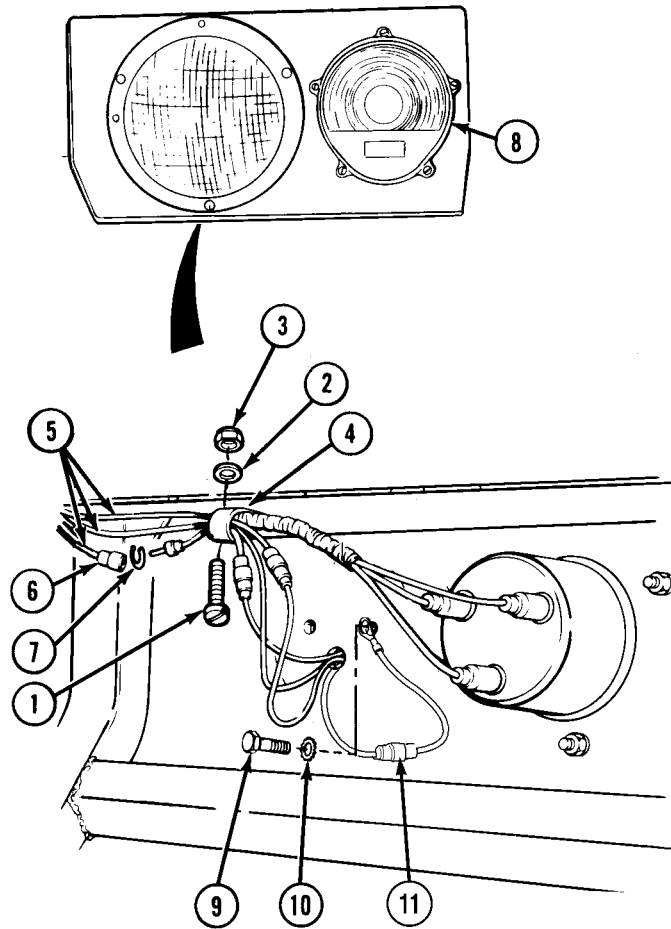
a. Removal.

- (1) Remove screw (1), washer (2), nut (3), and clamp (4).

NOTE

Tag and mark wires before disconnecting.

- (2) Disconnect three wires (5) at connectors (6).
- (3) Push three wires (5) back through connectors (6) and remove three C washers (7).
- (4) Soldier A holds front composite light (8) from outside of cab while Soldier B removes two screws (9) and lockwashers (10) (Model C only) and ground wire pigtail (11) from inside cab.
- (5) Remove front composite light (8) from outside of cab.



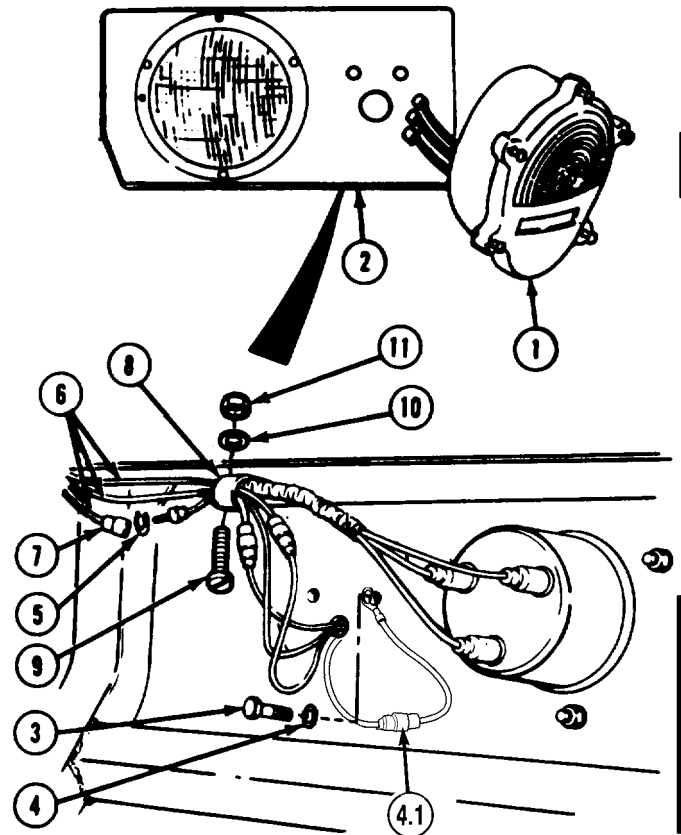
Electrical System Maintenance Instructions (Cont)

b. Installation.

- (1) Soldier A positions front composite light (1) in cab (2) while Soldier B installs two screws (3), lockwashers (4), and ground wire pigtail (4.1) (Model C only).
- (2) Connect three C washers (5) and three wires (6) at connectors (7).
- (3) Install clamp (8) on three wires (6) with screw (9), washers (10), and nut (11).

c. Follow-on Maintenance.

- (1) Install brake treadle valve (if removed) (para 11-10).
- (2) Connect batteries (para 7-91).
- (3) Check operation of front composite light (TM 9-2320-279-10).



END OF TASK

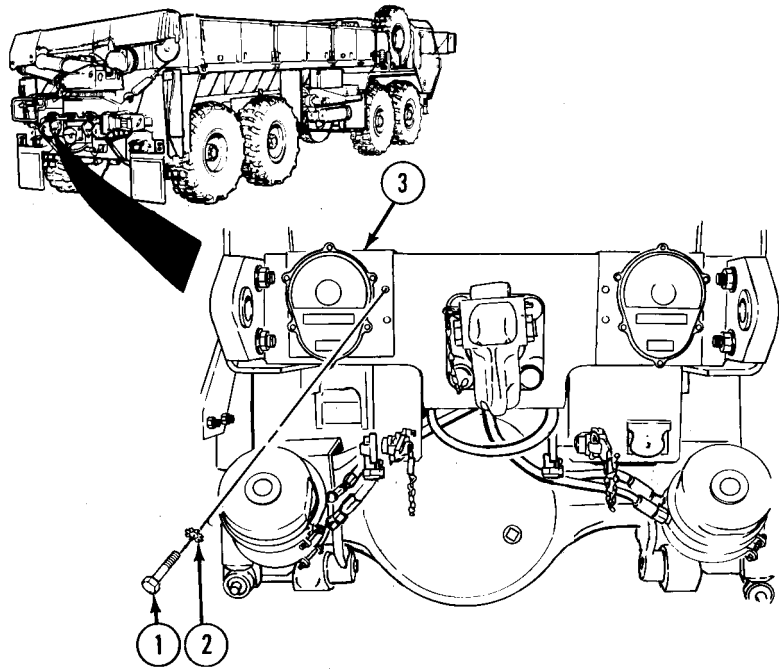
| 7-62. COMPOSITE TAILLIGHT ASSEMBLY REMOVAL/INSTALLATION. | |
|--|---|
| This task covers: | |
| a. Removal (M977, M983, M984, M985) | d. Installation (M984E1) |
| b. Installation (M977, M983, M984, M985) | e. Follow-on Maintenance |
| c. Removal (M984E1) | |
| INITIAL SETUP | |
| <i>Models</i> M977, M983, M984, M984E1, M985 | <i>References</i> None |
| <i>Test Equipment</i> None | <i>Equipment Condition</i> TM or Para Para 7-91 |
| <i>Special Tools</i> None | <i>Condition Description</i> Batteries disconnected. |
| <i>Supplies</i> Tags, identification, Item 48, Appendix C | <i>Special Environmental Conditions</i> None |
| <i>Personnel Required</i> MOS 63S, Heavy wheel vehicle mechanic | <i>General Safety Instructions</i> None |

Electrical System Maintenance Instructions (Cont)

7-62. COMPOSITE TAILLIGHT ASSEMBLY REMOVAL/INSTALLATION (CONT).

NOTE

- There are three types of rear composite lights.
- Model A has a larger lens than Model B.
- Model C is an LED composite light and has a ground wire pigtail.
- Removal and installation procedures are the same for Model A and B. Not all parts are interchangeable.
- Model B rear composite light has a printed circuit board for the blackout marker and the stop lamp.



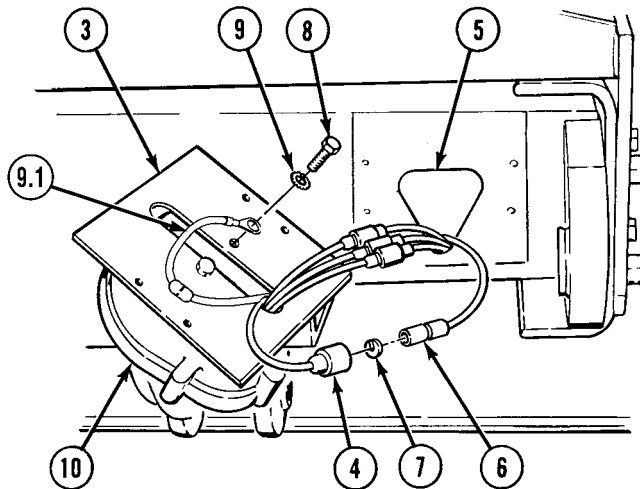
a. Removal (M977, M983, M984, M985).

- (1) Remove four screws (1) and lockwashers (2) from composite taillight bracket (3).
- (2) Pull four wires (4) from hole (5) until four connectors (6) are showing.

NOTE

Tag and mark wires before disconnecting.

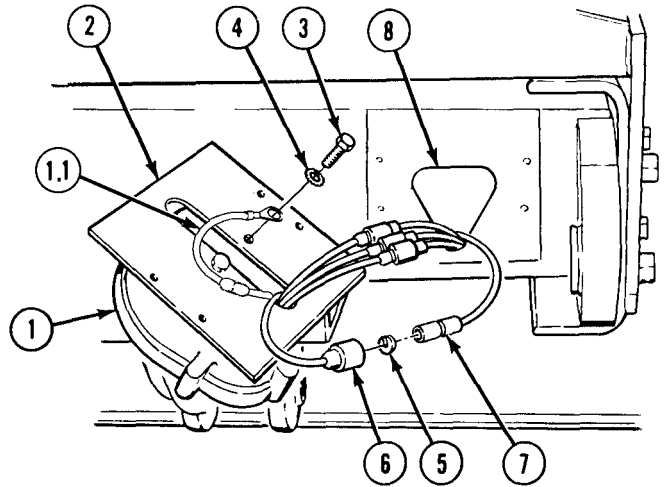
- (3) Disconnect four wires (4).
- (4) Push wires (4) back through connectors (6) and remove four C washers (7).
- (5) Remove two screws (8), lockwashers (9), ground wire pigtail (9.1) (Model C only), and composite taillight (10) from composite taillight bracket (3).



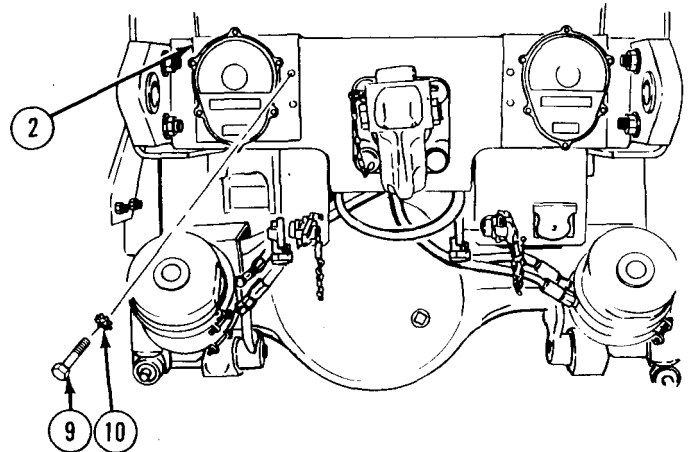
Electrical System Maintenance Instructions (Cont)

b. Installation (M977, M983, M984, M985).

- (1) Install composite light (1) and ground wire pigtail (1.1) (Model C only) on composite taillight bracket (2) with two screws (3) and lockwashers (4).
- (2) Install four C washers (5) on wires (6) and connect wires at connectors (7).
- (3) Push four wires (6) back through hole (8).



- (4) Install composite taillight bracket (2) with four screws (9) and lockwashers (10).



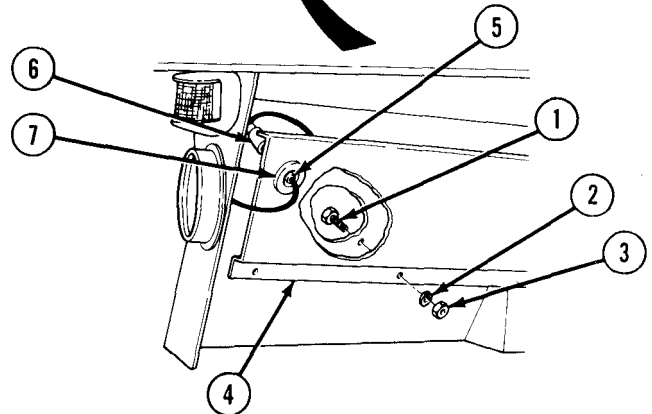
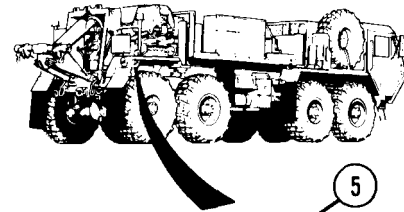
c. Removal (M984E1).

- (1) Remove three screws (1), lockwashers (2), and nuts (3) from cover (4).

NOTE

Tag and mark wires before disconnecting.

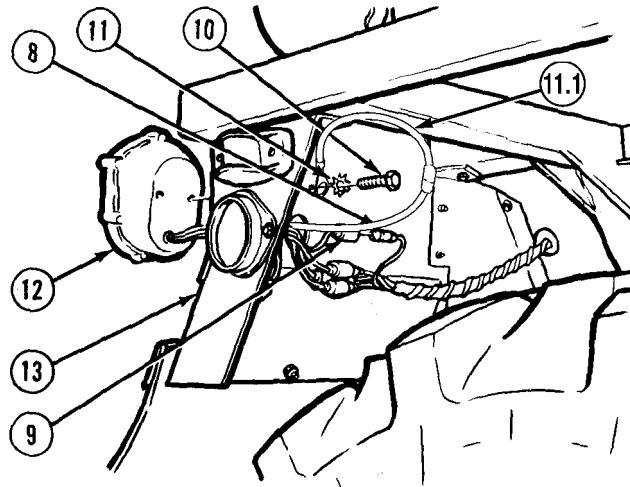
- (2) Disconnect wire (5) from wire (6) and remove cover (4).
- (3) Remove grommet (7) from cover (4).



Electrical System Maintenance Instructions (Cont)

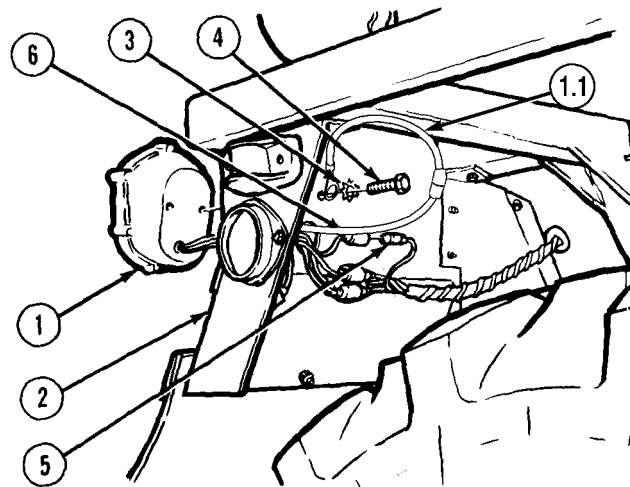
7-62. COMPOSITE TAILLIGHT ASSEMBLY REMOVAL/INSTALLATION (CONT).

- (4) Disconnect four wires (8) from connectors (9).
- (5) Remove two screws (10), lockwashers (11), ground wire pigtail (11.1) (Model C only), and composite taillight (12) from fender (13).

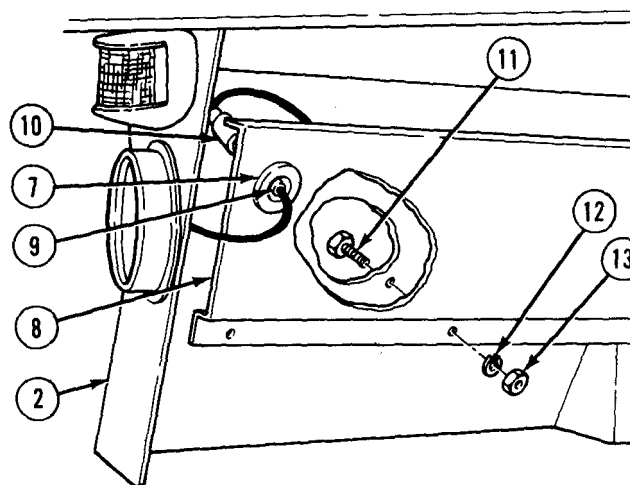


d. Installation (M984E1).

- (1) Install composite taillight (1) and ground wire pigtail (1.1) (Model C only) on fender (2) with two lockwashers (3) and screws (4).
- (2) Connect four wires (5) to connectors (6).



- (3) Install grommet (7) in cover (8).
- (4) Connect wire (9) at connector (10).
- (5) Install cover (8) on fender (2) with three screws (11), lockwashers (12), and nuts (13).



Electrical System Maintenance Instructions (Cont)

e. Follow-on Maintenance.

- (1) Connect batteries (para 7-91).
- (2) Check operation of composite taillights (TM 9-2320-279-10).

END OF TASK

| 7-62.1. HIGH MOUNT STOP LAMP ASSEMBLY REMOVAL/INSTALLATION (M978). | | |
|---|---|--------------------------------|
| This task covers: | | |
| a. Removal | | c. Follow-on Maintenance |
| b. Installation | | |
| INITIAL SETUP | | |
| <i>Models</i> | <i>References</i> | |
| M978 | None | |
| <i>Test Equipment</i> | <i>Equipment Condition</i> | |
| None | <i>TM or Para</i> | <i>Condition Description</i> |
| | Para 7-91 | Batteries disconnected. |
| <i>Special Tools</i> | TM 9-2320-279-10 | Pump module rear doors opened. |
| None | | |
| <i>Supplies</i> | <i>Special Environmental Conditions</i> | |
| Tags, identification, Item 48, Appendix C | None | |
| <i>Personnel Required</i> | <i>General Safety Instructions</i> | |
| MOS 63S, Heavy wheel vehicle mechanic | None | |

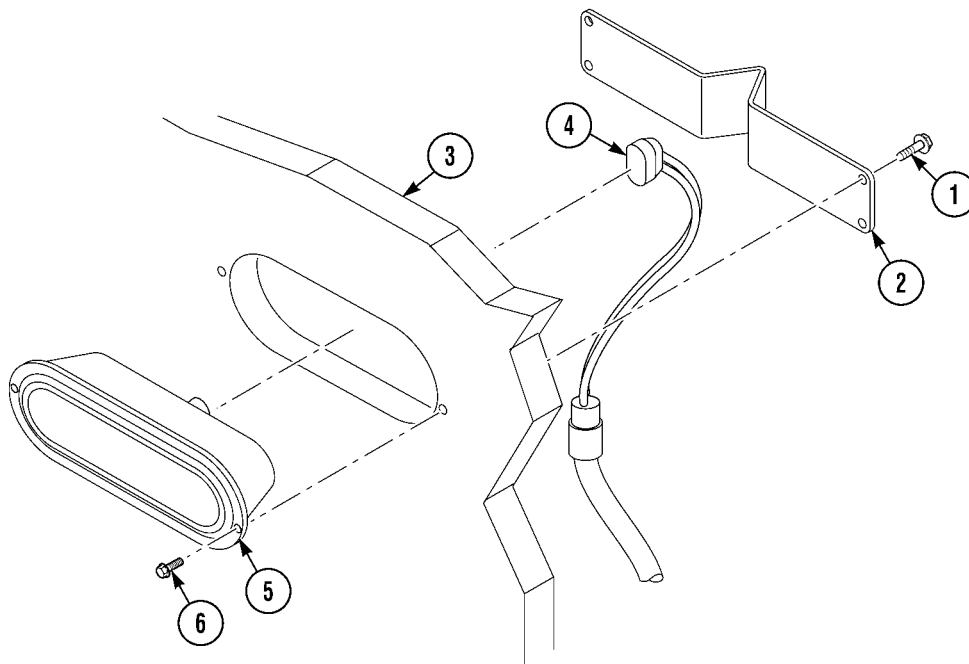
Electrical System Maintenance Instructions (Cont)

7-62.1. HIGH MOUNT STOP LAMP ASSEMBLY REMOVAL/INSTALLATION (M978) (CONT).

NOTE

- Vehicle may be equipped with two high mount stop lamps on rear of vehicle.
- Removal and installation procedures are the same for both.

a. Removal.



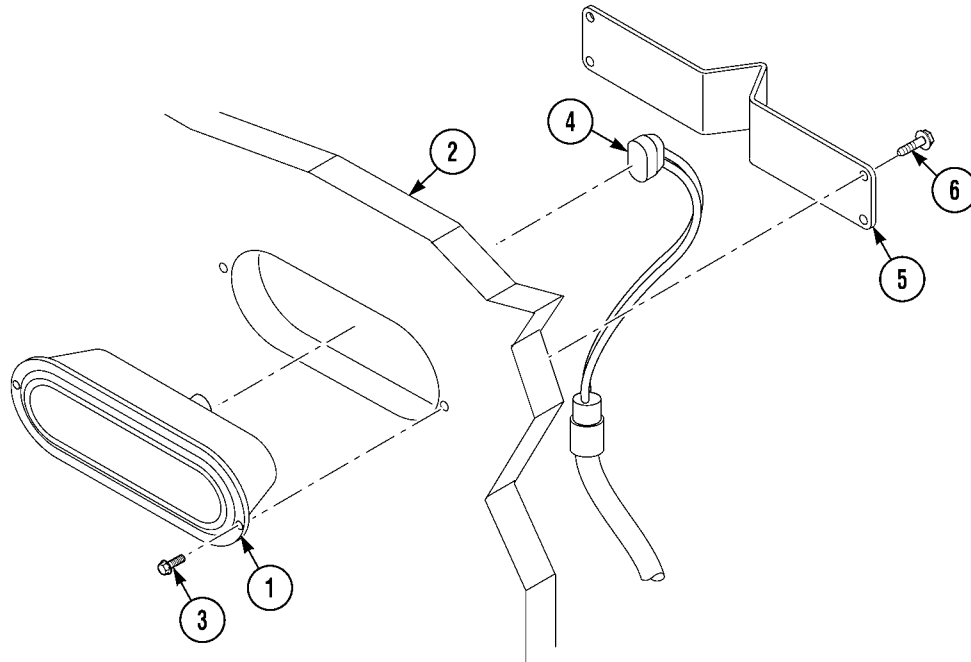
NOTE

Tag and mark wires before disconnecting.

- (1) Remove four screws (1) and guard (2) from rear door (3).
- (2) Disconnect connector (4) from high mount stop lamp (5).
- (3) Remove two screws (6) and high mount stop lamp (5) from rear door (3).

Electrical System Maintenance Instructions (Cont)

b. Installation.



- (1) Install high mount stop lamp (1) on door (2) with two screws (3).
- (2) Connect connector (4) to high mount stop lamp (1).
- (3) Install guard (5) on rear of door (2) with four screws (6).

c. Follow-on Maintenance.

- (1) Connect batteries (para 7-91).
- (2) Close pump module rear doors (TM 9-2320-279-10).
- (3) Check operation of high mount stop lamps.

END OF TASK

Electrical System Maintenance Instructions (Cont)

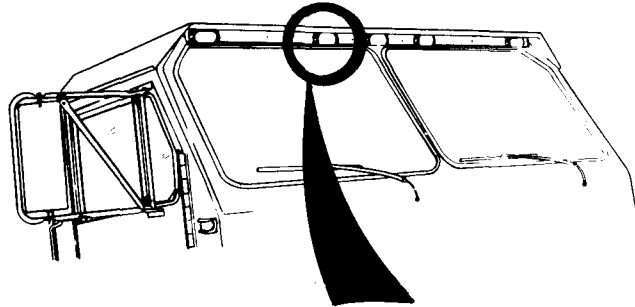
| | | |
|---|---|------------------------------|
| 7-63. FRONT CAB CLEARANCE LAMP REMOVAL/INSTALLATION. | | |
| This task covers: | | |
| a. Removal | | c. Follow-on Maintenance |
| b. Installation | | |
| INITIAL SETUP | | |
| <i>Models</i> | <i>References</i> | |
| All | None | |
| <i>Test Equipment</i> | <i>Equipment Condition</i> | |
| None | <i>TM or Para</i> | <i>Condition Description</i> |
| | Para 7-91 | Batteries disconnected. |
| <i>Special Tools</i> | <i>Special Environmental Conditions</i> | |
| None | None | |
| <i>Supplies</i> | <i>General Safety Instructions</i> | |
| None | None | |
| <i>Personnel Required</i> | | |
| MOS 63S, Heavy wheel vehicle mechanic | | |

Electrical System Maintenance Instructions (Cont)

7-63. FRONT CAB CLEARANCE LAMP REMOVAL/INSTALLATION (CONT).

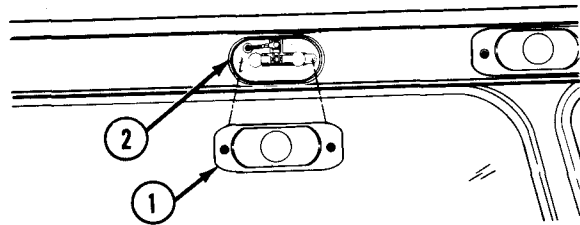
NOTE

- There are two types of clearance lights.
- Model A is a lamp type light.
- Model B is an LED type light and cannot be repaired.

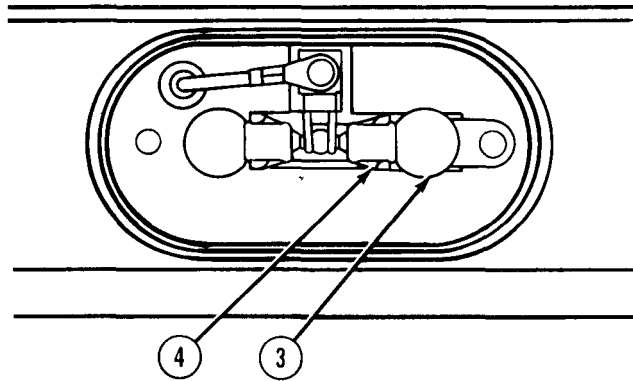


a. Removal.

- (1) Pry off lens (1) from clearance light assembly (2).

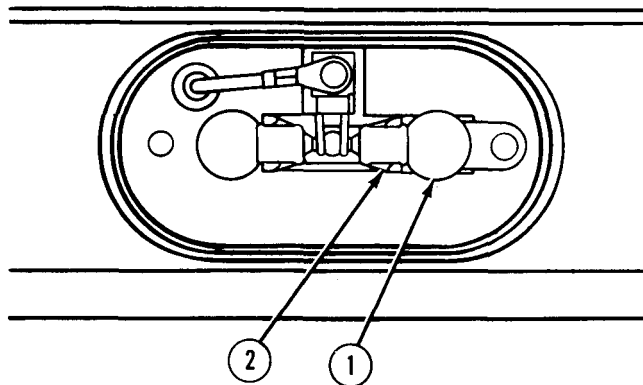


- (2) Remove lamp (3) from socket (4).



b. Installation.

- (1) Install lamp (1) in socket (2).

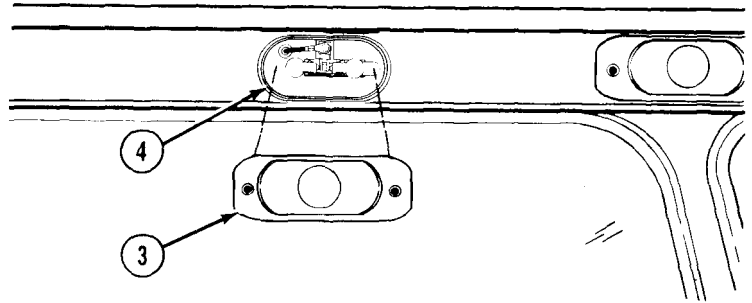


Electrical System Maintenance Instructions (Cont)

- (2) Install lens (3) on clearance light assembly (4).

c. Follow-on Maintenance.

- (1) Connect batteries (para 7-91).
- (2) Check operation of front cab clearance lights (TM 9-2320-279-10).



END OF TASK

| | |
|--|--|
| 7-64. FRONT CAB CLEARANCE LIGHT/LED ASSEMBLY AND MOUNTING BRACKET REMOVAL/INSTALLATION. | |
| This task covers: | |
| a. Removal | c. Follow-on Maintenance |
| b. Installation | |
| INITIAL SETUP | |
| <i>Models</i> | <i>References</i> |
| All | None |
| <i>Test Equipment</i> | <i>Equipment Condition</i> |
| None | <i>TM or Para</i> <i>Condition Description</i> |
| <i>Special Tools</i> | Para 7-91 Batteries disconnected. |
| Insert removal tool 114010 | |
| <i>Supplies</i> | <i>Special Environmental Conditions</i> |
| Connector, electrical butt, Item 19, Appendix C | None |
| Tubing, heat shrink, Item 53, Appendix C | <i>General Safety Instructions</i> |
| | None |
| <i>Personnel Required</i> | |
| MOS 63S, Heavy wheel vehicle mechanic | |

NOTE

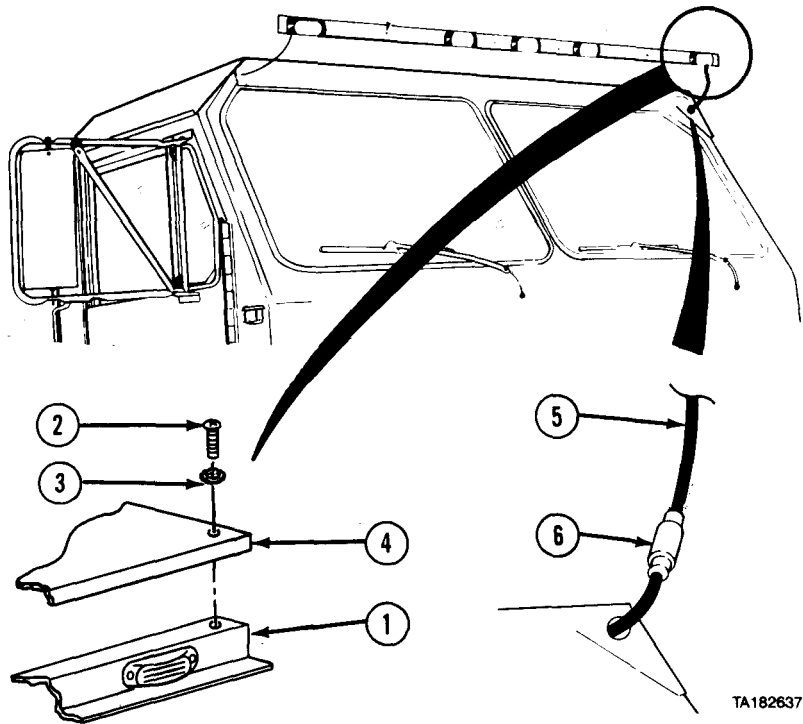
There are two configurations of clearance lights that may be installed on the vehicle. Model A is a lamp type clearance light and Model B is an LED type clearance light.

Electrical System Maintenance Instructions (Cont)

**7-64. FRONT CAB CLEARANCE LIGHT ASSEMBLY AND MOUNTING BRACKET
REMOVAL/INSTALLATION (CONT).**

a. Removal.

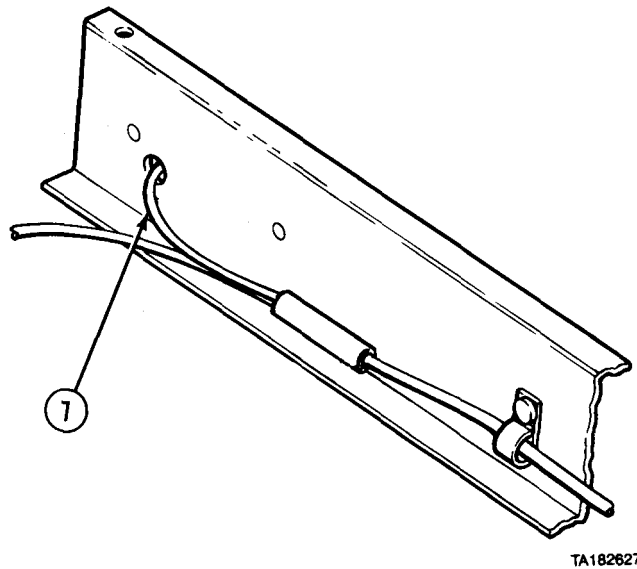
- (1) Support clearance light bracket (1).
- (2) Remove six screws (2) and lockwashers (3) from clearance light bracket (1) and cab (4).
- (3) Using insert removal tool, remove cable wire (5) from connector (6).
- (4) Remove clearance light bracket (1) from cab (4).



NOTE

When cutting clearance light assembly wire, leave enough wire exposed to connect another butt connector.

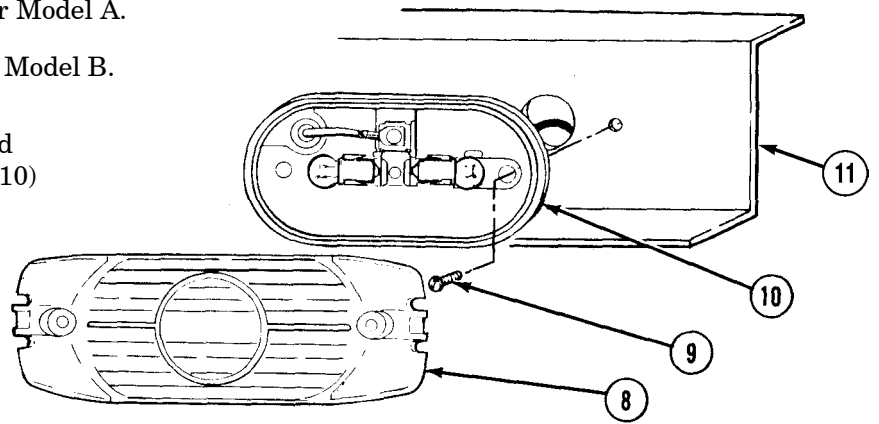
- (5) Cut clearance light assembly wire (7).



Electrical System Maintenance Instructions (Cont)

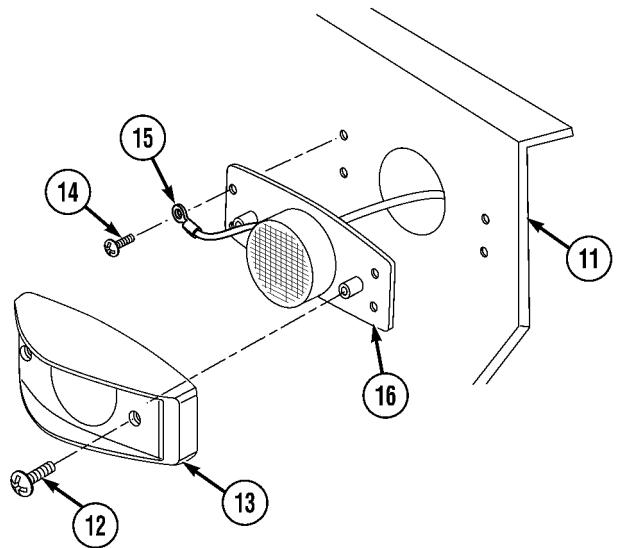
NOTE

- Perform steps (6 and 7) for Model A.
 - Perform step (8 and 9) for Model B.
- (6) Remove lens (8).
- (7) Remove two screws (9) and clearance light assembly (10) from bracket (11).



MODEL A

- (8) Remove two screws (12) and LED clearance light assembly (13).
- (9) Remove two screws (14), ground wire (15), and LED clearance light base (16).



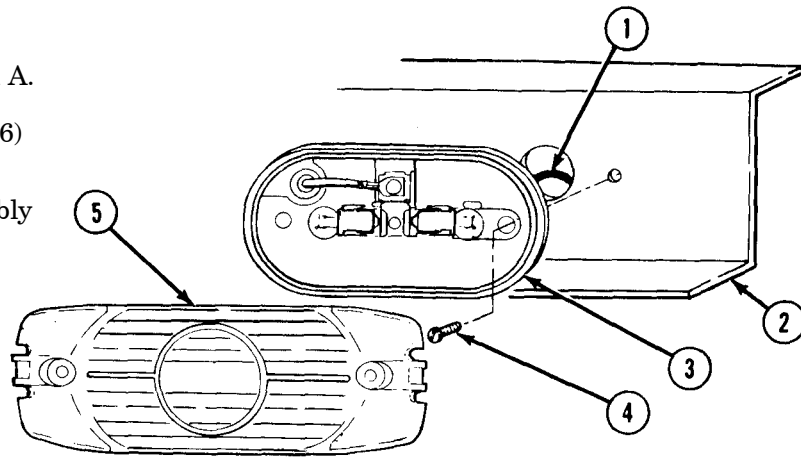
MODEL B

b. Installation.

NOTE

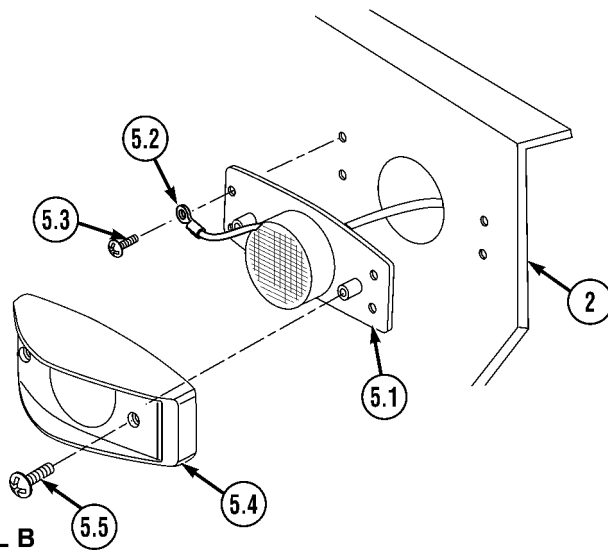
- Perform steps (1) through (3) and (4) through (6) for Model A.
- Perform steps (3.1) through (6) for Model B.

- (1) Install clearance light assembly wire (1) in clearance light bracket (2).
- (2) Install clearance light assembly (3) with two screws (4).
- (3) Install lens (5).



MODEL A

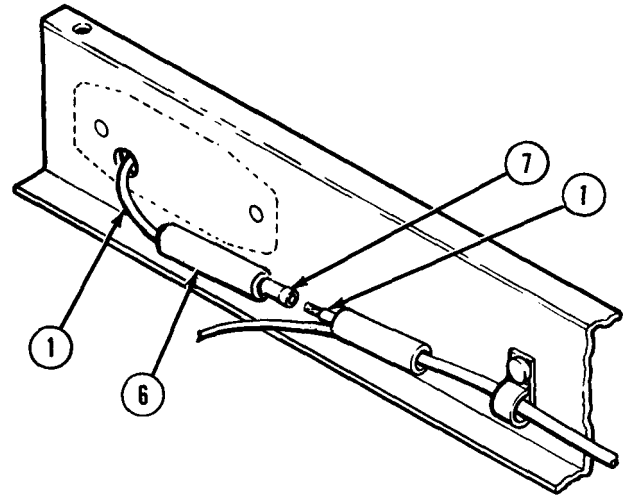
- (3.1) Install LED clearance light assembly base (5.1) and ground wire (5.2) with two screws (5.3).
- (3.2) Install LED clearance light assembly (5.4) with two screws (5.5) on bracket (2).



MODEL B

Electrical System Maintenance Instructions (Cont)

- (4) Slide heat shrink tubing (6) over clearance light assembly wire (1).
- (5) Connect clearance light assembly wire (1) with electrical butt connector (7).
- (6) Install heat shrink tubing (6) over electrical butt connector (7).



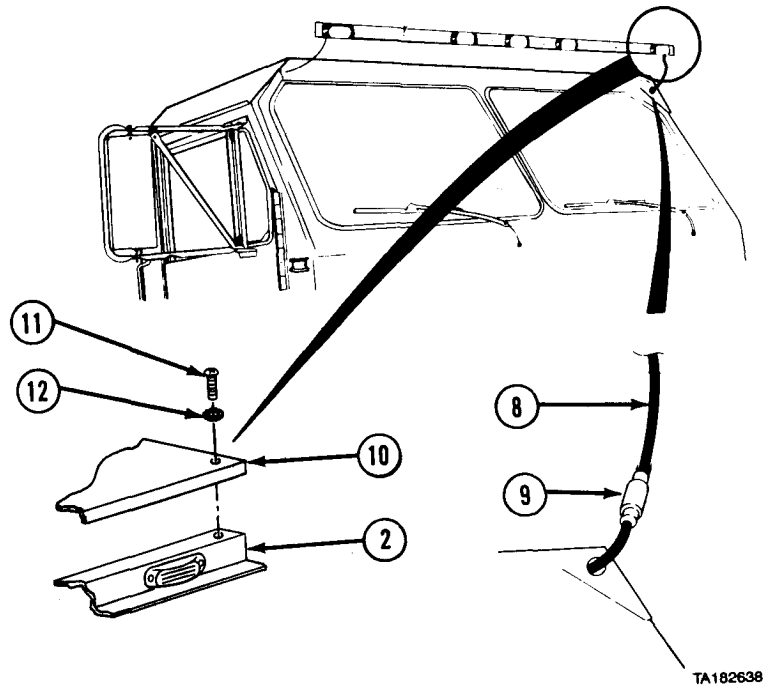
Electrical System Maintenance Instructions (Cont)

7-64. FRONT CAB CLEARANCE LIGHT ASSEMBLY AND MOUNTING BRACKET
REMOVAL/INSTALLATION (CONT).

- (7) Install cable wire (8) in connector (9).
- (8) Install clearance light bracket (2) on cab (10) with six screws (11) and lockwashers (12).

- c. *Follow-on Maintenance.*
- (1) Connect batteries (para 7-91).
 - (2) Check operation of front cab clearance lights (TM 9-2320-279-10).

END OF TASK



Electrical System Maintenance Instructions (Cont)

7-65. STEP, SIDE, AND REAR CLEARANCE, AND SIDE TURN LIGHT REMOVAL/INSTALLATION.

This task covers:

- a. Removal
- b. Installation

c. Follow-on Maintenance

INITIAL SETUP

Models

All

Test Equipment

None

Special Tools

None

Supplies

None

Personnel Required

MOS 63S, Heavy wheel vehicle mechanic

References

None

Equipment Condition

| <i>TM or Para</i> | <i>Condition Description</i> |
|-------------------|------------------------------|
| TM 9-2320-279-10 | Shut off engine. |
| TM 9-2320-279-10 | Clearance light switch off. |

Special Environmental Conditions

None

General Safety Instructions

None

a. Removal.

NOTE

Lights are removed in a similar manner. Step clearance light is shown.

- (1) Remove two screws (1).
- (2) Remove lens (2).
- (3) Remove lamp (3) from lampholder (4).

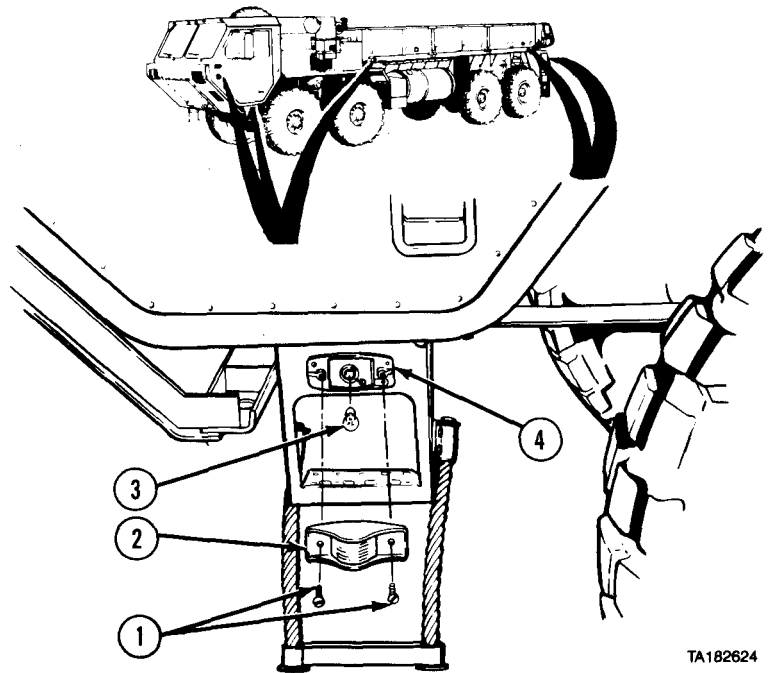
b. Installation.

- (1) Install lamp (3) in lampholder (4).
- (2) Install lens (2).
- (3) Install two screws (1).

c. Follow-on Maintenance.

Check operation of step, side, and rear clearance, and side turn lights (TM 9-2320-279-10).

END OF TASK



TA182624

Electrical System Maintenance Instructions (Cont)

7-66. SIDE AND REAR CLEARANCE LIGHTS/LED REMOVAL/INSTALLATION (M977, M983, M984, M985).

This task covers:

- a. Removal
- b. Installation
- c. Follow-on Maintenance

INITIAL SETUP

Models

M977, M983, M984, M985

Test Equipment

None

Special Tools

None

Supplies

None

Personnel Required

MOS 63S, Heavy wheel vehicle mechanic

References

None

Equipment Condition

TM or Para *Condition Description*
 TM 9-2320-279-10 Shut off engine.

Special Environmental Conditions

None

General Safety Instructions

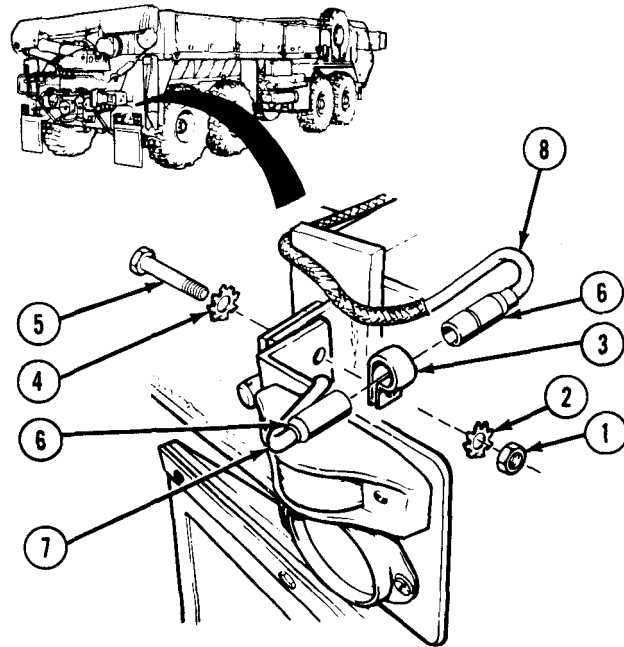
None

a. Removal.

NOTE

- There are two configurations of clearance lights that may be installed on the vehicle.
- Model A is a lamp type clearance light.
- Model B is an LED type clearance light.
- Cab, step, side, and rear clearance lights are removed the same way.
- M984 left and right rear clearance lights are mounted on fenders.
- Do step (1) for right and left rear clearance lights only.

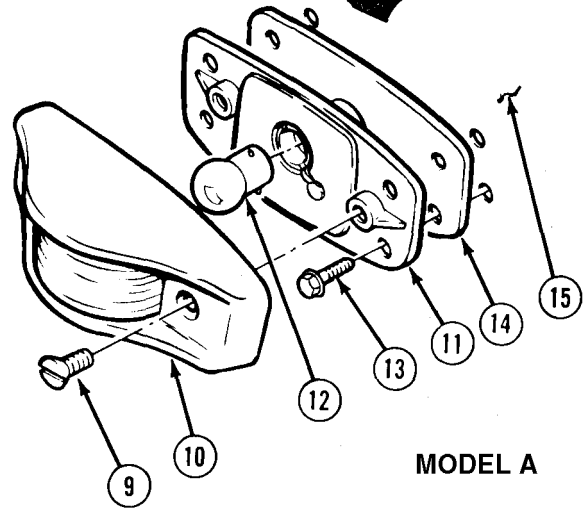
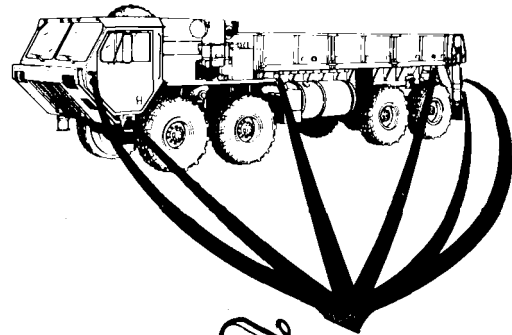
- (1) Remove nut (1), lockwasher (2), cushion clip (3), lockwasher (4), and screw (5). Remove cushion clip from connectors (6).
- (2) Disconnect clearance light assembly wire (7) from wire (8) at connectors (6).



Electrical System Maintenance Instructions (Cont)

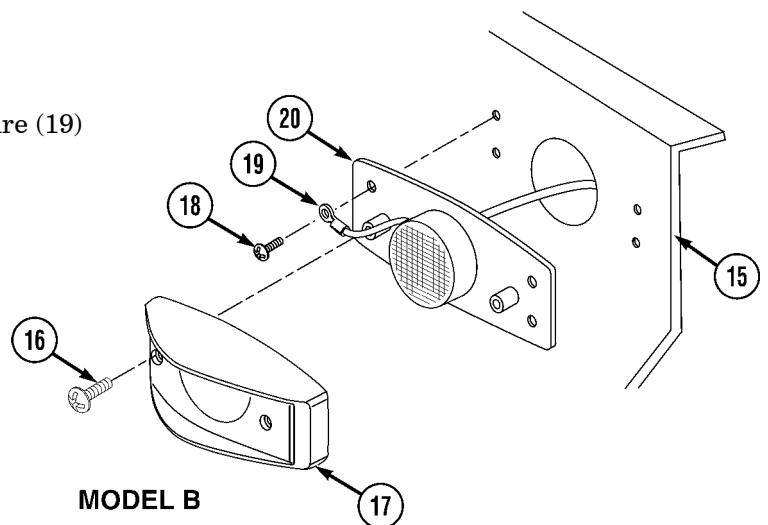
NOTE

- Perform steps (3) through (5) for Model A.
 - Perform steps (6 and 7) for Model B.
- (3) Remove two screws (9) and lens (10) from lampholder (11).
 - (4) Remove lamp (12).
 - (5) Remove two screws (13), lampholder (11), and gasket (14) from bracket (15).



MODEL A

- (6) Remove two screws (16) and LED clearance light assembly (17) from base (20).
- (7) Remove four screws (18) ground wire (19) and base (20) from bracket (15).



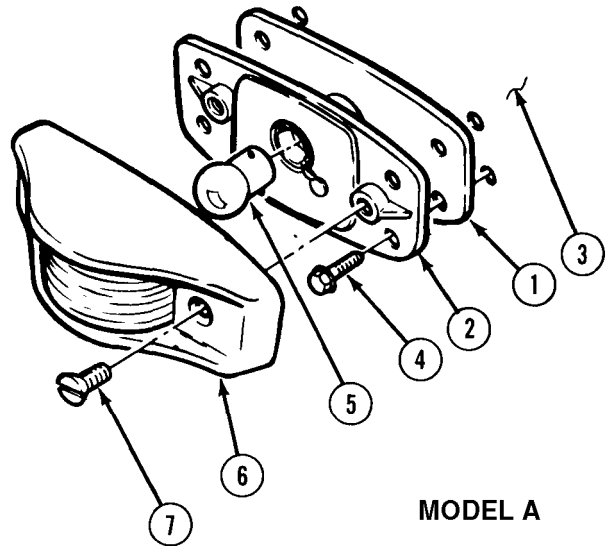
MODEL B

Electrical System Maintenance Instructions (Cont)

b. **Installation.**

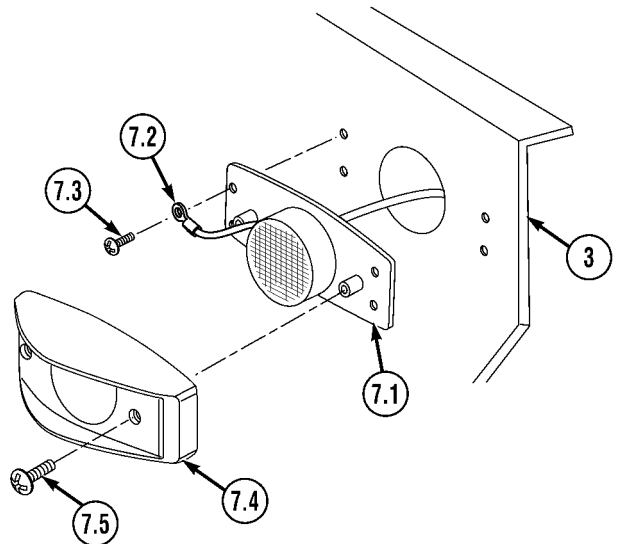
NOTE

- There are two configurations of clearance lights that may be installed on the vehicle. Model A is a bulb type clearance light and Model B is an LED type clearance light.
 - Cab, step, side, and rear clearance lights are installed the same way.
 - Perform steps (1) through (3) and (4) and (5) for Model A.
 - Perform steps (3.1) and (3.2) for Model B.
- (1) Install gasket (1) and lampholder (2) on bracket (3) with two screws (4).
 - (2) Install lamp (5).
 - (3) Install lens (6) on lampholder (2) with two screws (7).



MODEL A

- (3.1) Install base (7.1) and ground wire (7.2) on bracket (3) with four screws (7.3).
- (3.2) Install LED clearance light assembly (7.4) on base (7.1) with two screws (7.5).



MODEL B

Electrical System Maintenance Instructions (Cont)

7-66. SIDE AND REAR CLEARANCE LIGHTS REMOVAL/INSTALLATION (M977, M983, M984, M985) (CONT).

(4) Connect wire (8) to clearance light assembly wire (9) at connectors (10).

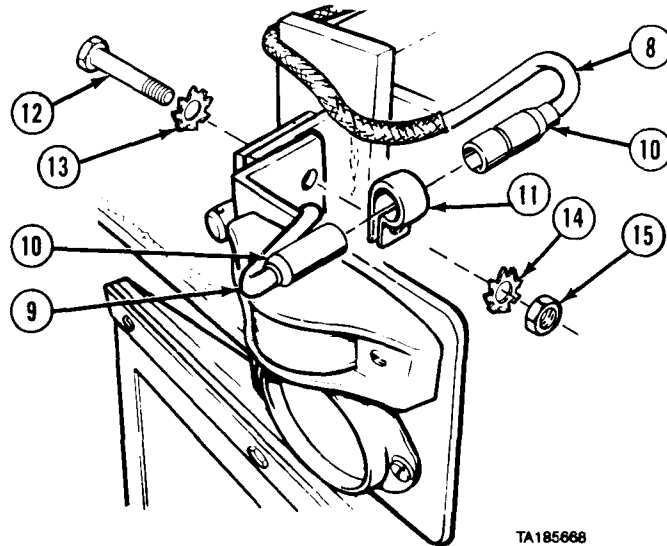
NOTE

Do step (5) for right and left rear clearance lights only.

(5) Install cushion clip (11) on connectors (10). Install cushion clip with screw (12), lockwasher (13), lockwasher (14), and nut (15).

c. Follow-on Maintenance. Check operation of side and rear clearance lights (TM 9-2320-279-10).

END OF TASK



7-67. SIDE AND REAR CLEARANCE LIGHT BRACKETS REMOVAL/INSTALLATION (M977, M984, M985).

This task covers:

- | | |
|--|--|
| a. Rear Clearance Light Brackets Removal (M977, M985) | e. Center Rear Clearance Light Bracket Removal (M977, M985) |
| b. Rear Clearance Light Brackets Installation (M977, M985) | f. Center Rear Clearance Light Bracket Installation (M977, M985) |
| c. Rear Clearance Light Bracket Removal (M984) | g. Follow-on Maintenance |
| d. Rear Clearance Light Bracket Installation (M984) | |

INITIAL SETUP

Models
M977, M984, M985

Test Equipment
None

Special Tools
None

Supplies
None

Personnel Required
MOS 63S, Heavy wheel vehicle mechanic

References
None

Equipment Condition

| <i>TM or Para</i> | <i>Condition Description</i> |
|-------------------|--------------------------------|
| Para 7-66 | Rear clearance lights removed. |
| Para 17-6 | Rear cable guide removed. |

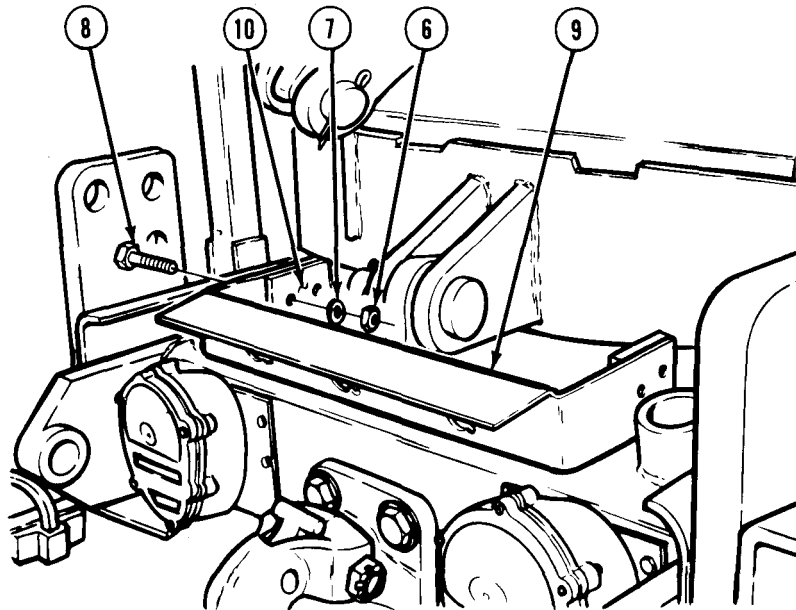
Special Environmental Conditions
None

General Safety Instructions
None

Electrical System Maintenance Instructions (Cont)

7-67. SIDE AND REAR CLEARANCE LIGHT BRACKETS REMOVAL/INSTALLATION (M977, M984, M985) (CONT).

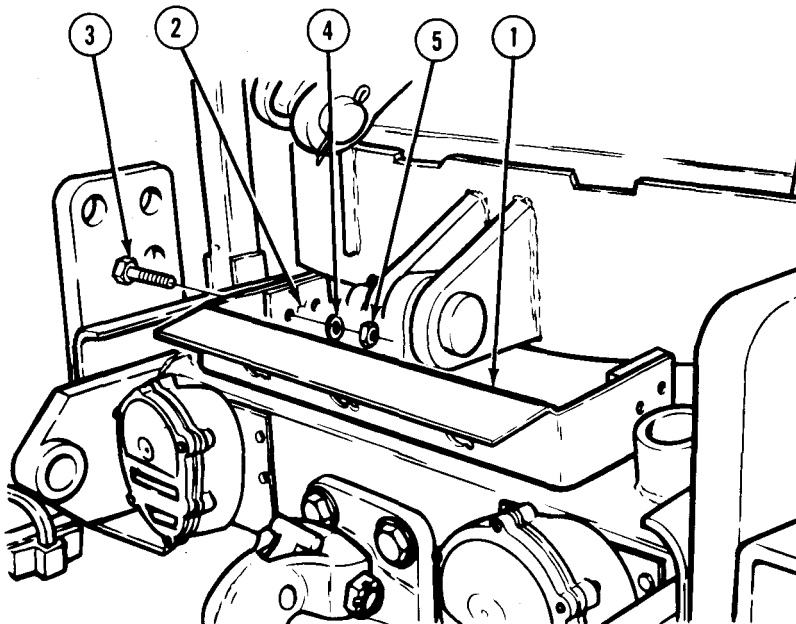
- (2) Remove four nuts (6), lockwashers (7), screws (8), and clearance light bracket (9) from winch mounting bracket (10).



TA185679

d. Rear Clearance Light Bracket Installation (M984).

- (1) Install clearance light bracket (1) on winch mounting bracket (2) with four screws (3), lockwashers (4), and nuts (5).



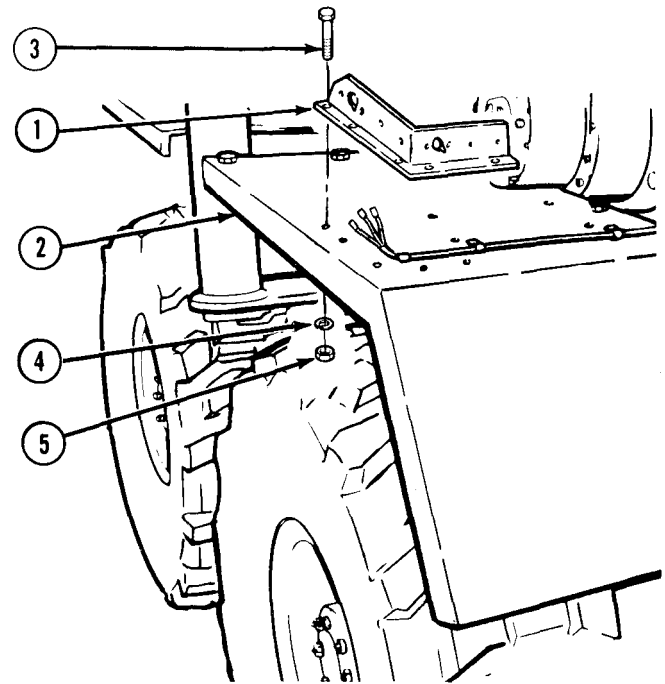
TA185680

Electrical System Maintenance Instructions (Cont)

NOTE

Left and right rear clearance light brackets are installed the same way.

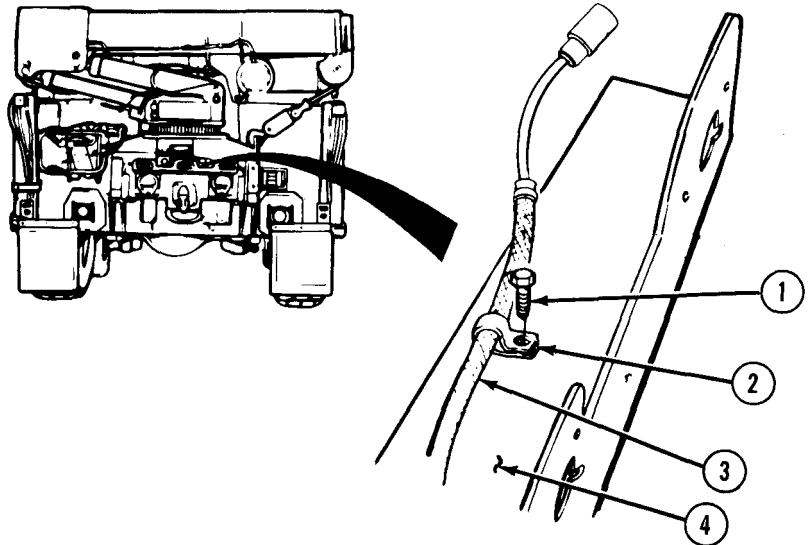
- (2) Install clearance light bracket (1) on fender (2) with five screws (3), three lockwashers (4), and nuts (5).



TA185681

e. Center Rear Clearance Light Brackets Removal (M977, M985).

- (1) Remove two screws (1), cushion clips (2), and cable (3) from clearance light bracket (4).

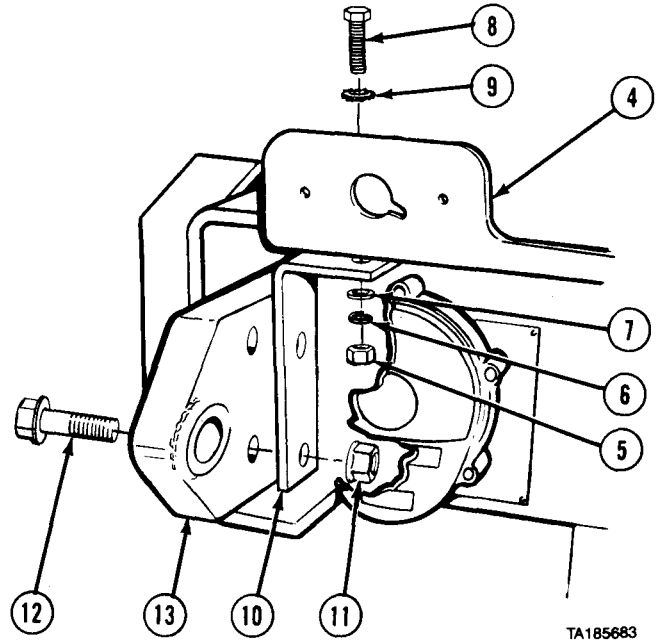


TA185682

Electrical System Maintenance Instructions (Cont)

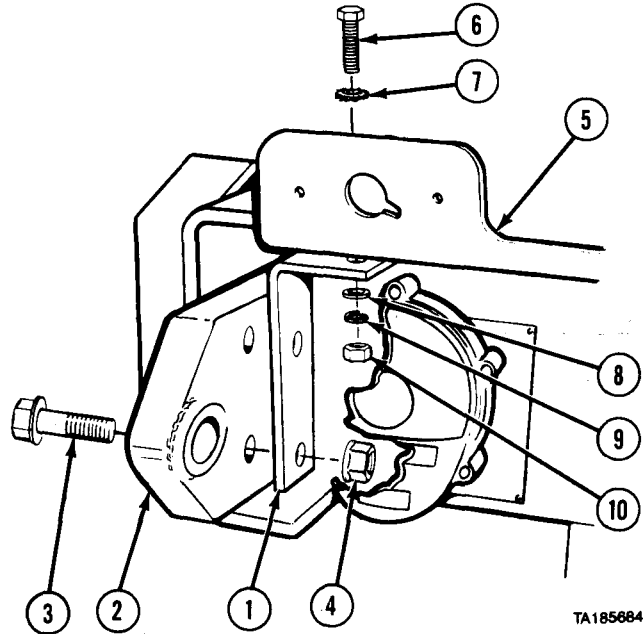
7-67. SIDE AND REAR CLEARANCE LIGHT BRACKETS REMOVAL/INSTALLATION (M977, M984, M985) (CONT).

- (2) Remove two nuts (5), lockwashers (6), washers (7), screws (8), lockwashers (9), and clearance light bracket (4) from two mounting brackets (10).
- (3) Remove four nuts (11), screws (12), and two mounting brackets (10) from rear crossmember (13).



f. Center Rear Clearance Light Brackets Installation (M977, M985).

- (1) Install two mounting brackets (1) on crossmember (2) with four screws (3) and nuts (4). Tighten nuts to 910 lb-ft (1234 N·m).
- (2) Install clearance light bracket (5) on mounting bracket (1) with two screws (6), lockwashers (7), washers (8), lockwashers (9), and nuts (10).



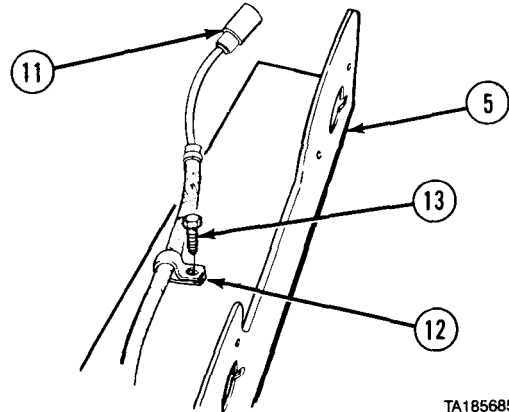
Electrical System Maintenance Instructions (Cont)

- (3) Install cable (11) on clearance light bracket (5) with two cushion clips (12) and screws (13).

g. Follow-on Maintenance.

- (1) Install rear cable guide (para 17-6).
- (2) Install rear clearance lights (para 7-66).

END OF TASK



TA185685

7-67.1. REAR SIDE CLEARANCE MARKER LIGHTS REMOVAL/INSTALLATION (M984E1).

This task covers:

- a. Removal
- b. Installation

c. Follow-on Maintenance

INITIAL SETUP

Models

M984E1

Test Equipment

None

Special Tools

None

Supplies

None

Personnel Required

MOS 63S, Heavy wheel vehicle mechanic

References

None

Equipment Condition

| <i>TM or Para</i> | <i>Condition Description</i> |
|-------------------|------------------------------|
| TM 9-2320-279-10 | Shut off engine. |
| TM 9-2320-279-10 | Clearance lamps switch off. |
| Para 7-91 | Batteries disconnected. |

Special Environmental Conditions

None

General Safety Instructions

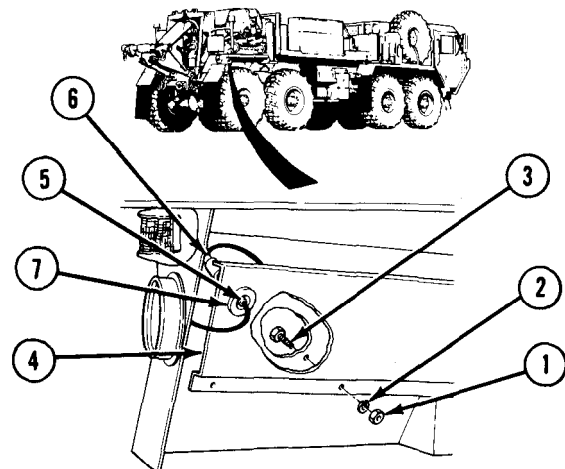
None

a. Removal.

NOTE

Left and right rear side clearance lights are removed the same way.

- (1) Remove three nuts (1), lockwashers (2), screws (3), and cover (4).
- (2) Disconnect connector (5) from wire (6).
- (3) Remove grommet (7) and connector (5) from cover (4).

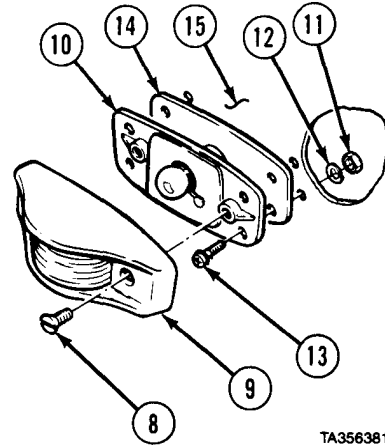


TA476177

Electrical System Maintenance Instructions (Cont)

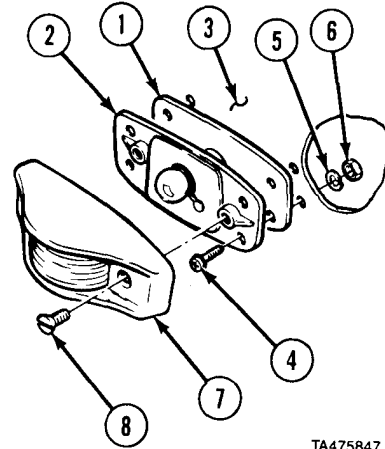
7-67.1. REAR SIDE CLEARANCE MARKER LIGHTS REMOVAL/INSTALLATION (M984E1)
(CONT).

- (4) Remove two screws (8) and lens (9) from lampholder (10).
- (5) Remove four nuts (11), lockwashers (12), screws (13), lampholder (10), and gasket (14) from fender assembly (15).

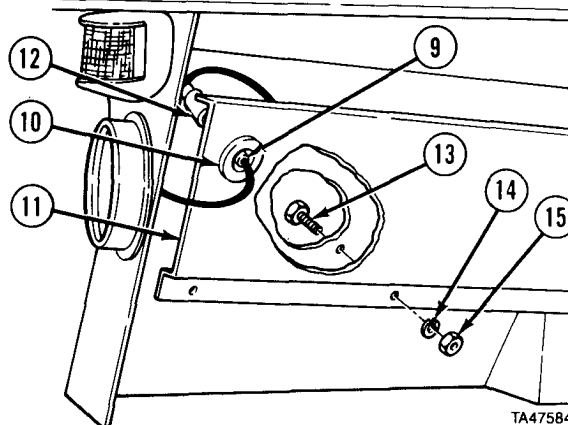


b. Installation.

- (1) Install gasket (1) and lampholder (2) on fender (3) with four screws (4), lockwashers (5), and nuts (6).
- (2) Install lens (7) on lampholder (2) with two screws (8).



- (3) Install connector (9) and grommet (10) on cover (11).
- (4) Connect wire (12) to connector (9).
- (5) Install cover (11) with three screws (13), lockwashers (14), and nuts (15).



c. Follow-on Maintenance.

- (1) Connect batteries (para 7-91).
- (2) Check operation of rear side clearance lamps (TM 9-2320-279-10).

END OF TASK

Electrical System Maintenance Instructions (Cont)

7-67.2. REAR CLEARANCE MARKER LIGHTS AND BRACKET REMOVAL/INSTALLATION (M984E1).

This task covers:

- a. Removal
- b. Installation

c. Follow-on Maintenance

INITIAL SETUP

Models

M984E1

Test Equipment

None

Special Tools

None

Supplies

Tags, identification, Item 48, Appendix C
Ties, cable, plastic, Item 52, Appendix C

Personnel Required

MOS 63S, Heavy wheel vehicle mechanic

References

None

Equipment Condition

| <i>TM or Para</i> | <i>Condition Description</i> |
|-------------------|------------------------------|
| Para 7-91 | Batteries disconnected. |
| TM 9-2320-279-10 | Shut off engine. |

Special Environmental Conditions

None

General Safety Instructions

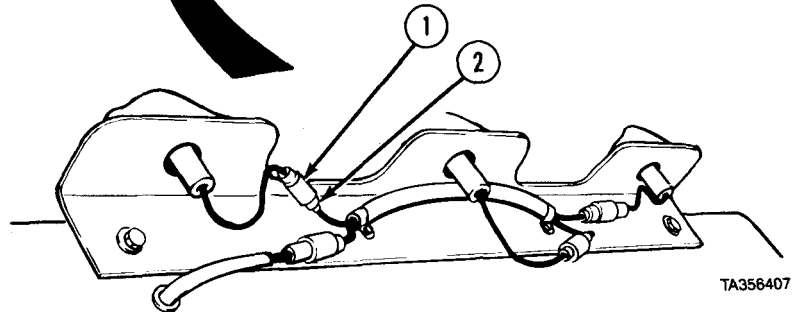
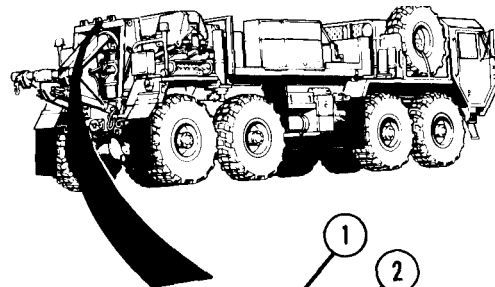
None

a. Removal.

NOTE

- All three clearance lights are removed the same way.
- Tag and mark wires when disconnecting.

(1) Disconnect wire (1) from connector (2).



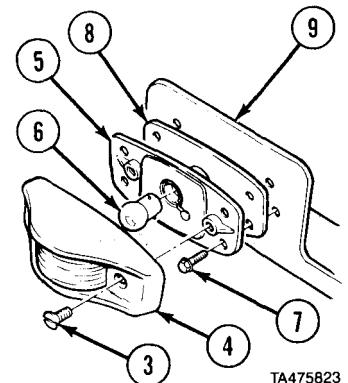
(2) Remove two screws (3) and lens (4) from lampholder (5).

(3) Remove lamp (6).

NOTE

Cut plastic cable ties as necessary.

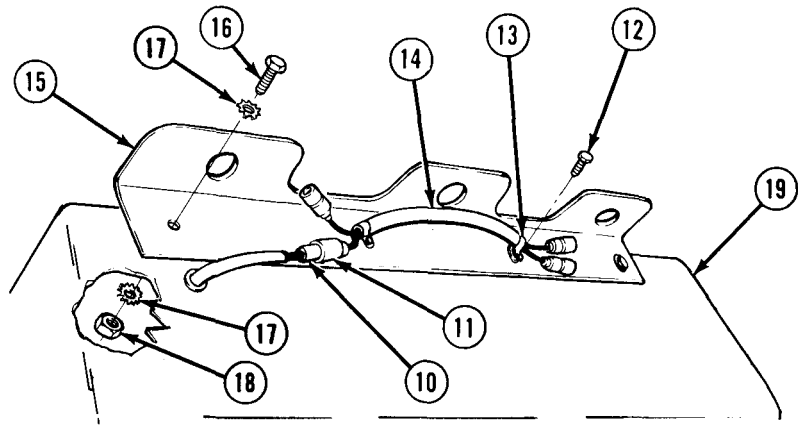
(4) Remove two screws (7), lampholder (5), and gasket (6) from bracket (9).



Electrical System Maintenance Instructions (Cont)

7-67.2. REAR CLEARANCE MARKER LIGHTS AND BRACKET REMOVAL/INSTALLATION (M984E1) (CONT).

- (5) Disconnect wire (10) from connector (11).
- (6) Remove two screws (12), clamps (13), and harness (14) from bracket (15).
- (7) Remove two screws (16), four lockwashers (17), two nuts (18), and bracket (15) from towing support assembly (19).



TA475824

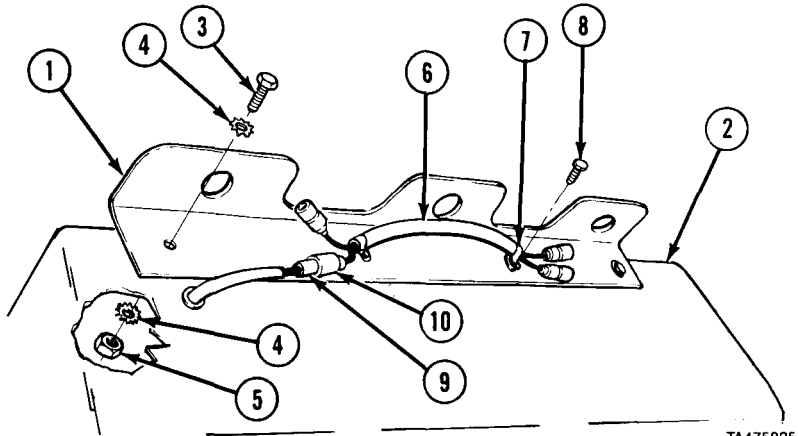
b. Installation.

- (1) Install bracket (1) on towing support assembly (2) with two screws (3), four lockwashers (4), and two nuts (5).

NOTE

Replace plastic cable ties as necessary.

- (2) Install harness (6) on bracket (1) with two clamps (7) and screws (8).
- (3) Connect wire (9) to connector (10).

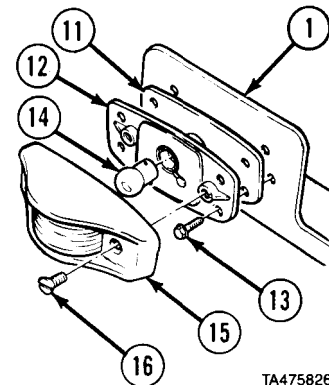


TA475825

NOTE

All three clearance lights are installed the same way.

- (4) Install gasket (11) and lampholder (12) on bracket (1) with two screws (13).
- (5) Install lamp (14),
- (6) Install lens (15) on lampholder (12) with two screws (16),

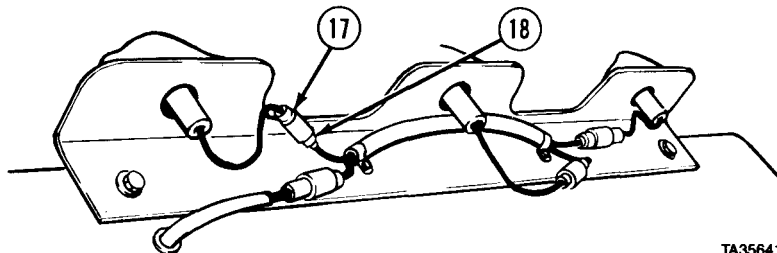


TA475826

- (7) Connect wire (17) to connector (18).

c. Follow-on Maintenance.

- (1) Connect batteries (para 7-91).
- (2) Check operation of rear clearance lamps (TM 9-2320-279-10).



TA356410

END OF TASK

Electrical System Maintenance Instructions (Cont)

7-68. BLACKOUT LIGHT ASSEMBLY REMOVAL/INSTALLATION.

This task covers:

- a. Removal
- b. Installation

c. Follow-on Maintenance

INITIAL SETUP

Models

AU

References

None

Test Equipment

None

Equipment Condition

| TM or Para | Condition | Description |
|------------------|-----------|-------------------------------|
| TM 9-2320-279-10 | | Main light switch turned off. |
| Para 7-91 | | Batteries disconnected. |

Special Tools

None

Special Environment Conditions

None

Supplies

None

General Safety Instructions

None

Personnel Required

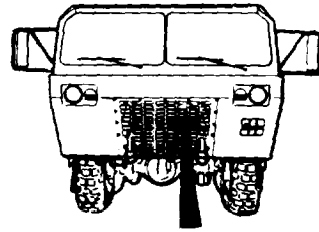
MOS 63S. Heavy wheel vehicle mechanic

Electrical System Maintenance Instructions (Cont)

7-68. BLACKOUT LIGHT ASSEMBLY REMOVAL/INSTALLATION (CONT).

NOTE

There are two types of blackout lights. Model A has three screws securing door. Model B has four screws. Removal and installation procedures are the same. Not all parts are interchangeable.



a. Removal.

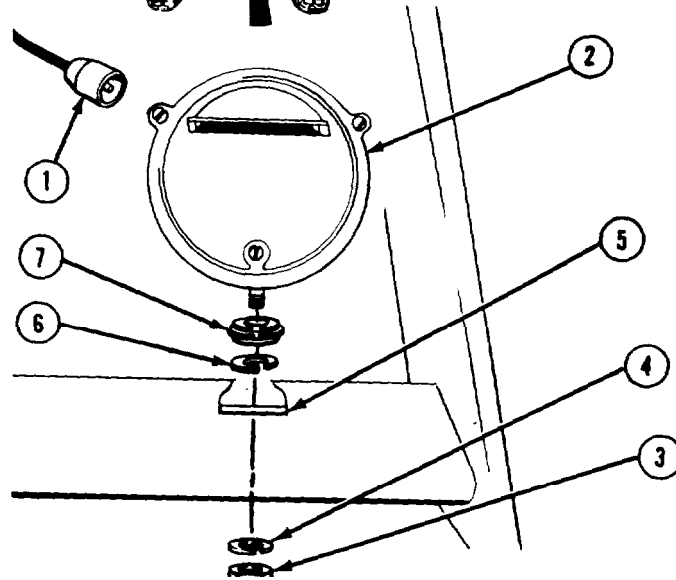
- (1) Remove wire (1) from back of blackout light assembly (2).
- (2) Remove nut (3), lockwasher (4), and blackout light assembly (2) from support bracket (5).
- (3) Remove lockwasher (6) and washer (7) from blackout light assembly (2).

b. Installation.

- (1) Install washer (7) and lockwasher (6) on blackout light assembly (2).
- (2) Install blackout light assembly (2) on support bracket (5).
- (3) Install lockwasher (4) and nut (3) to support bracket (5).
- (4) Connect wire (1) on back of blackout light assembly (2).

c. Follow-on Maintenance.

- (1) Connect batteries (para 7-91).
- (2) Check operation of blackout light (TM 9-2320-279-10).



END OF TASK

7-69. BLACKOUT LIGHT LAMP REMOVAL/INSTALLATION.

This task covers:

- a. Removal
- b. Installation

c. Follow-on Maintenance

INITIAL SETUP

Models

All

Test Equipment

None

Special Tools

None

Supplies

None

Personnel Required

MOS 63S, Heavy wheel vehicle mechanic

References

None

Equipment Condition

TM or Para Condition Description
 TM 9-2320-279-10 Shut off engine.

Special Environmental Conditions

None

General Safety Instructions

None

Electrical System Maintenance Instructions (Cont)

a. Removal.

NOTE

There are two types of blackout lights. Model A has three screws securing the door. Model B has four screws. Do steps (1) and (2) for Model A. Do steps (1.1) and (2.1) for Model B.

- (1) Loosen three captive screws (1) and remove door assembly (2) from blackout light assembly (3).
- (1.1) Loosen four captive screws (3.1) and remove door assembly (3.2) from blackout light assembly (3.3).
- (2) Remove gasket (4), preformed packing (5), and lamp (6) from blackout light assembly (3).
- (2.1) Remove gasket (6.1) and lamp (6.2) from blackout light assembly (3.3).

b. Installation.

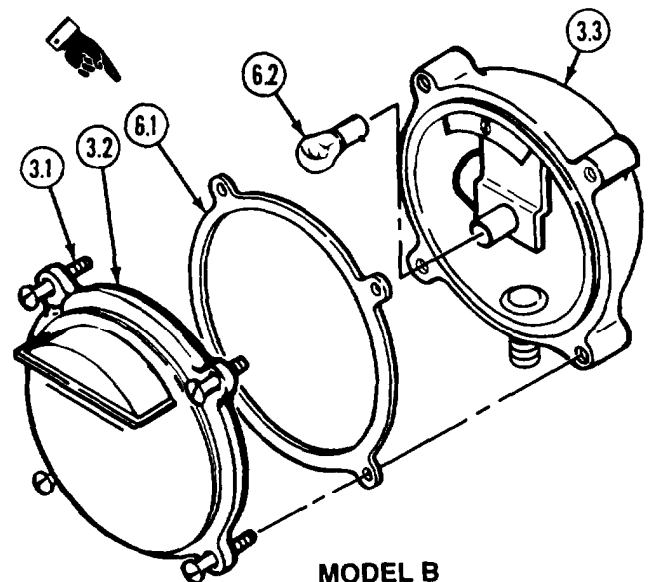
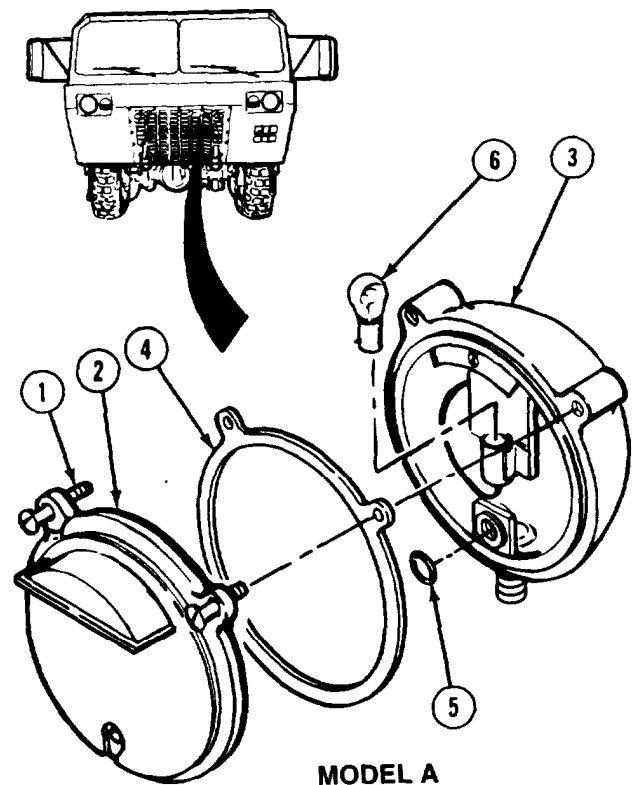
CAUTION

Keep all moisture and oils off lamp. Do not touch lamp with bare hands. Use a clean, dry, oil free cloth to hold lamp while installing lamp in blackout light.

NOTE

Do steps (2) and (3) for Model A. Do steps (2.1) and (3.1) for Model B.

- (1) Install lamp (6) and preformed packing (5) in blackout light assembly (3).
- (2) Install gasket (4) and door assembly (2).
- (2.1) Install lamp (6.2), gasket (6.1) and door assembly (3.2).
- (3) Tighten three captive screws (1).
- (3.1) Tighten four captive screws (3.1).



- c. **Follow-on Maintenance.** Check operation of blackout light (TM 9-2320-279-10).

END OF TASK

Electrical System Maintenance Instructions (Cont)

| | |
|---|--|
| 7-70. DOMELIGHT ASSEMBLY REMOVAL/INSTALLATION. | |
| This task covers: | |
| a. Removal | c. Follow-on Maintenance |
| b. Installation | |
| INITIAL SETUP | |
| Models | References |
| All | None |
| Test Equipment | Equipment Condition |
| None | TM or Para Condition Description |
| Special Tools | TM 9-2320-279-10 Domelight switch turned off. |
| None | Para 7-91 Batteries disconnected. |
| Supplies | Special Environmental Conditions |
| Tags, identification, Item 48, Appendix C | None |
| Personnel Required | General Safety Instructions |
| MOS 63S, Heavy wheel vehicle mechanic | None |

Electrical System Maintenance Instructions (Cont)

7-70. DOMELIGHT ASSEMBLY REMOVAL/INSTALLATION (CONT).

a. Removal.

- (1) Remove two screws (1) and lens (2) from domelight housing (3).
- (2) Remove lamp (4) from socket (5).
- (3) Remove two screws (6) and bracket (7).

NOTE

Tag and mark wires before disconnecting.

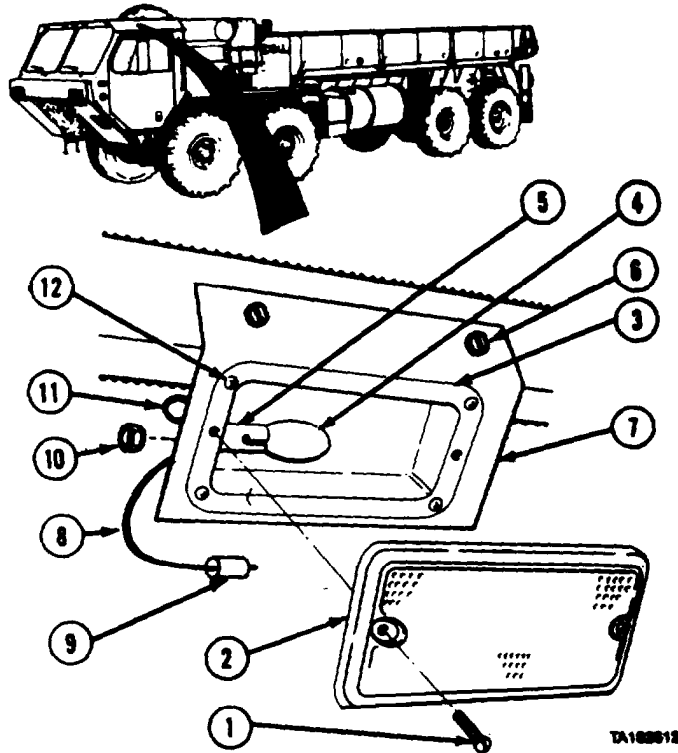
- (4) Disconnect domelight wire (8) at connector (9).
- (5) Remove nut (10) and disconnect ground wire (11) from upper left screw (12).
- (6) Remove four screws (12) and domelight housing (3) from bracket (7).

b. Installation.

- (1) Install four screws (12) and domelight housing (3) to bracket (7).
- (2) Connect ground wire (11) to upper left screw (12) with nut (10).
- (3) Connect domelight wire (8) at connector (9).
- (4) Install bracket (7) on cab with two screws (6).
- (5) Install lamp (4) in socket (5).
- (6) Install lens (2) on domelight housing (3) with two screws (1).

c. Follow-on Maintenance.

- (1) Connect batteries (para 7-91).
- (2) Check operation of domelight (TM 9-2320-279-10).



END OF TASK

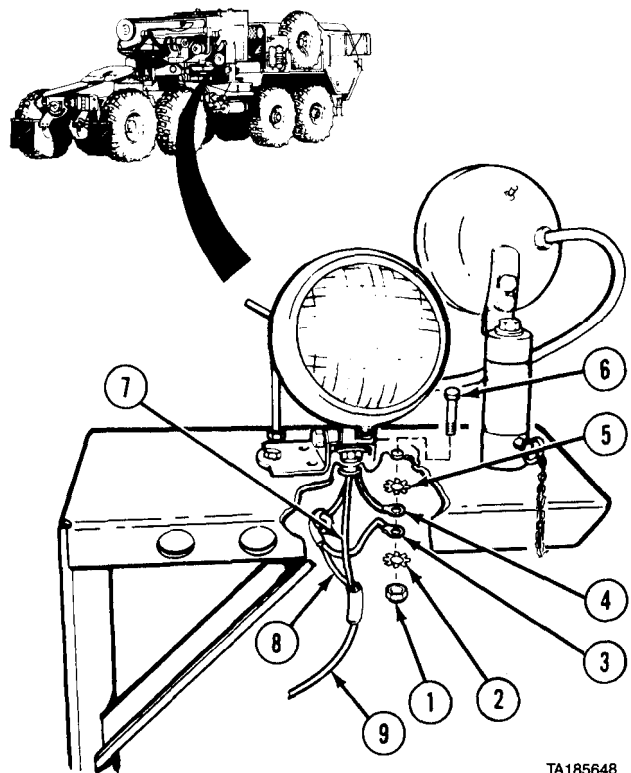
Electrical System Maintenance Instructions (Cont)

| | |
|--|--|
| 7-71. WORK LAMPS REMOVAL/INSTALLATION (M983). | |
| This task covers: | |
| a. Removal | c. Follow-on Maintenance |
| b. Installation | |
| INITIAL SETUP | |
| <i>Models</i> | <i>References</i> |
| M983 | None |
| <i>Test Equipment</i> | <i>Equipment Condition</i> |
| None | <i>TM or Para</i> <i>Condition Description</i> |
| <i>Special Tools</i> | Para 7-91 Batteries disconnected. |
| None | <i>Special Environmental Conditions</i> |
| <i>Supplies</i> | None |
| Connector, electrical, butt, Item 19, Appendix C | <i>General Safety Instructions</i> |
| Tags, identification, Item 48, Appendix C | None |
| <i>Personnel Required</i> | |
| MOS 63S, Heavy wheel vehicle mechanic | |

a. Removal.

NOTE

- Tag and mark wires before removing.
 - Wire terminals must be cut before work lamps are removed.
- (1) Remove nut (1), lockwasher (2), two wires (3 and 4), lockwasher (5), and screw (6).
 - (2) Cut wires (7 and 8) from wire (9). Untie knot.

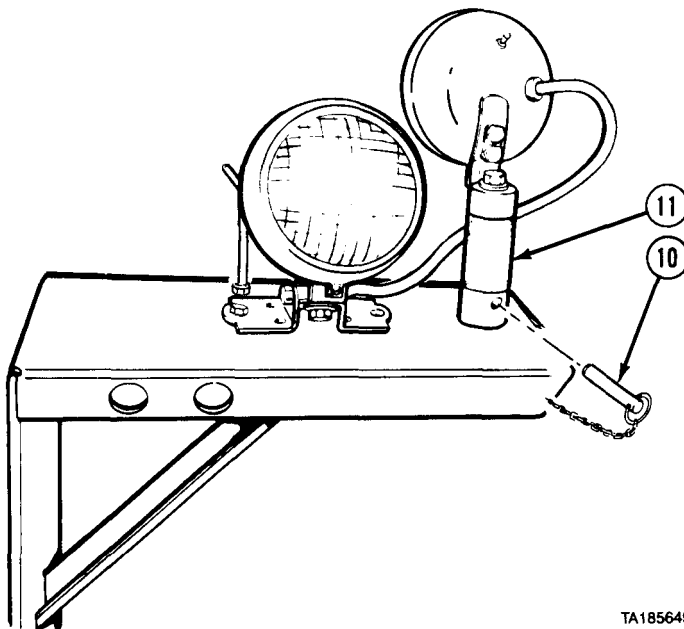


TA185648

Electrical System Maintenance Instructions (Cont)

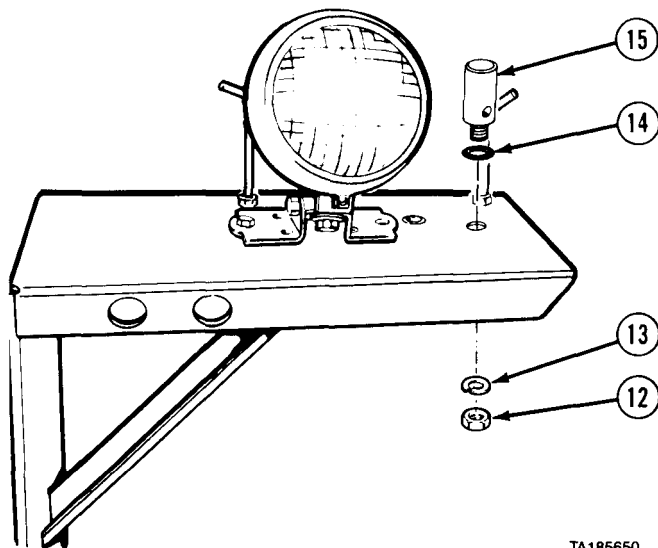
7-71. WORK LAMPS REMOVAL/INSTALLATION (M983) (CONT).

(3) Remove pin (10) and work lamp (11).



TA185649

(4) Remove nut (12), ockwasher (13), preformed packing (14), and mounting stud (15).



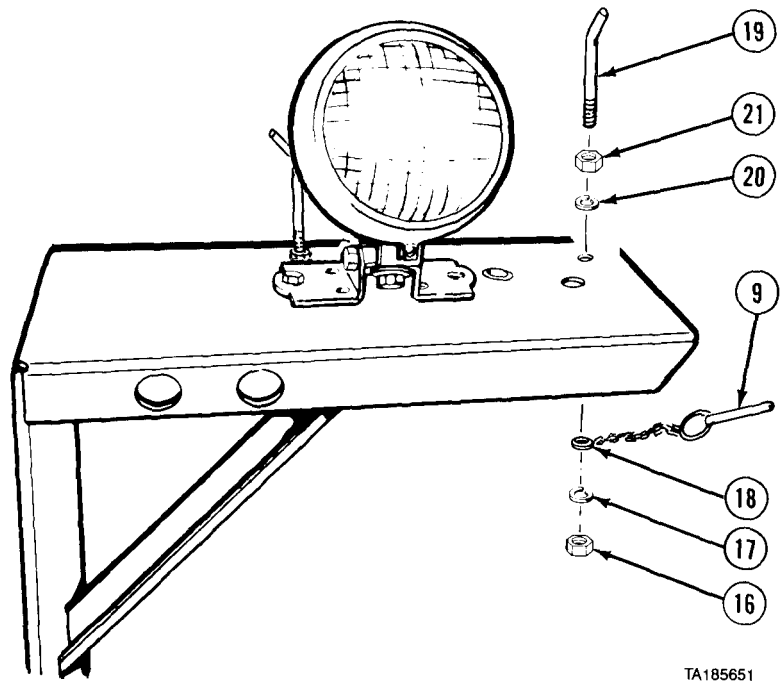
TA185650

Electrical System Maintenance Instructions (Cont)

NOTE

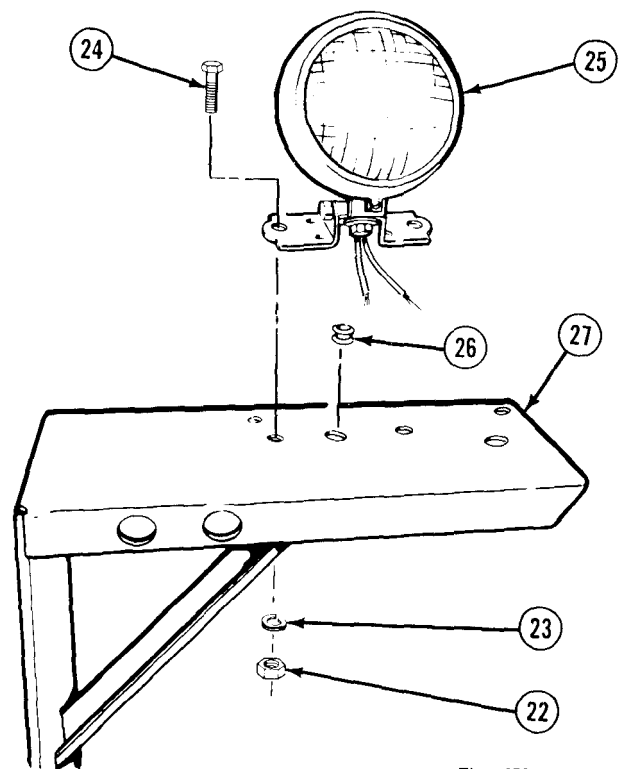
Outside hook has chain and pin attached.

- (5) Remove two nuts (16), lockwashers (17), and chain (18). Remove two hooks (19), lockwashers (20), and nuts (21).
- (6) Remove chain (18) from pin (9).



TA185651

- (7) Remove nut (22), lockwasher (23), screw (24), and work lamp (25).
- (8) Remove grommet (26) from mounting bracket (27).



TA185652

Electrical System Maintenance Instructions (Cont)

7-71. WORK LAMPS REMOVAL/INSTALLATION (M983) (CONT).

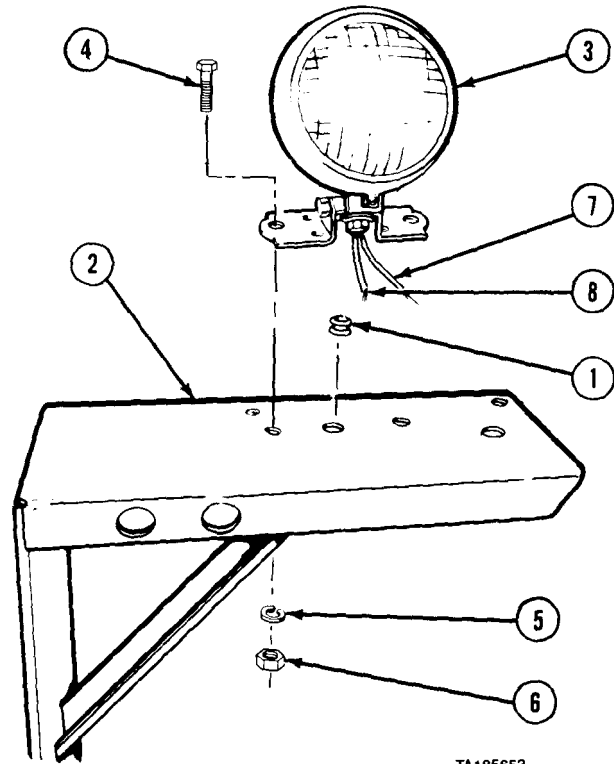
b. Installation.

- (1) Install grommet (1) in mounting bracket (2).
- (2) Install work lamp (3) with screw (4), lockwasher (5), and nut (6).

NOTE

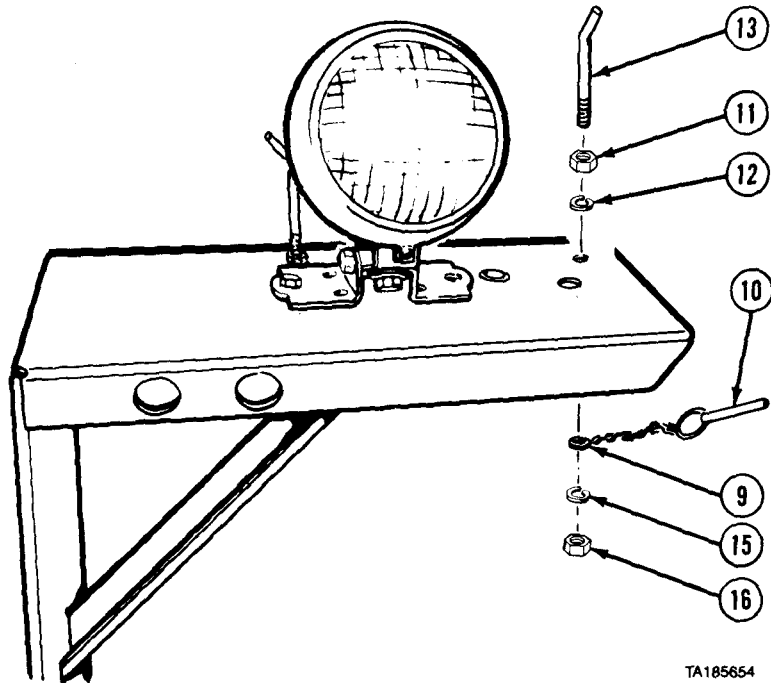
Wire terminals must be installed after wires are threaded through grommet.

- (3) Push wires (7 and 8) through grommet (1).



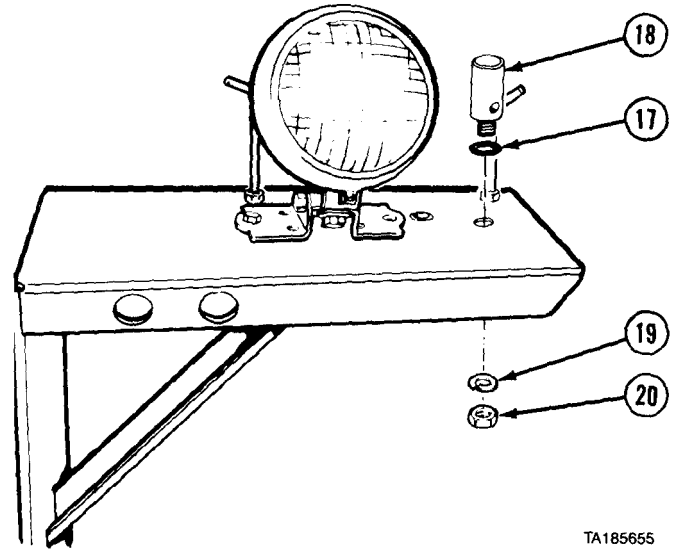
Outside hook has chain and pin attached.

- (4) Attach chain (9) to pin (10).
- (5) Install two nuts (11) and lockwashers (12) on hooks (13).
- (6) Install two hooks (13) and chain (9) with two lockwashers (15) and nuts (16).



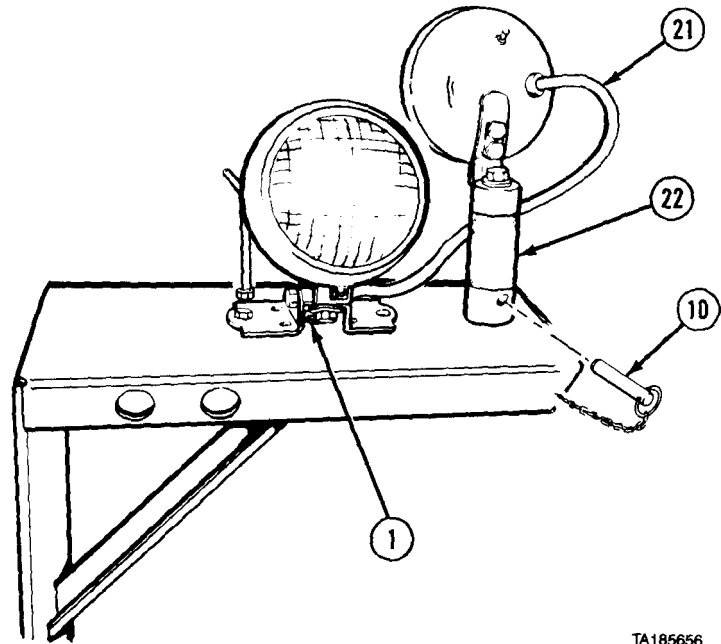
Electrical System Maintenance Instructions (Cont)

- (7) Install preformed packing (17) and mounting stud (18) with lockwasher (19) and nut (20).



TA185655

- (8) Push 1 ft (305 mm) of wire (21) through grommet (1) and install removable work lamp (22) with pin (10).



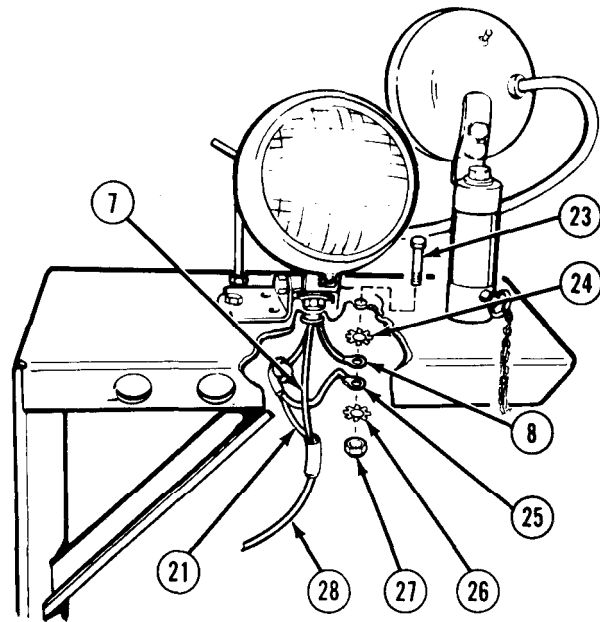
TA185656



Electrical System Maintenance Instructions (Cont)

7-71. WORK LAMPS REMOVAL/INSTALLATION (M983) (CONT).

- (9) Tie knot in wire (21).
 - (10) Install screw (23), lockwasher (24), two wires (8 and 25), lockwasher (26), and nut (27).
 - (11) Connect two wires (7 and 21) to wire (28) using butt connector.
- c. *Follow-on Maintenance.*
- (1) Connect batteries (para 7-91).
 - (2) Check operation of work lamps (TM 9-2320-279-10).



TA185657

END OF TASK

7-72. WORK LAMPS AND BRACKET REMOVAL/INSTALLATION (M9841).

This task covers:

- a. Removal
- b. Installation

c. Follow-on Maintenance

INITIAL SETUP

Models

M984

Test Equipment

None

Special Tools

None

Supplies

Connector, electrical, butt, Item 19, Appendix C
 Tags, identification, Item 48, Appendix C

Personnel Required

MOS 63S, Heavy wheel vehicle mechanic

References

None

Equipment Condition

| | |
|-------------------|------------------------------|
| <i>TM or Para</i> | <i>Condition Description</i> |
| Para 7-91 | Batteries disconnected. |

Special Environmental Conditions

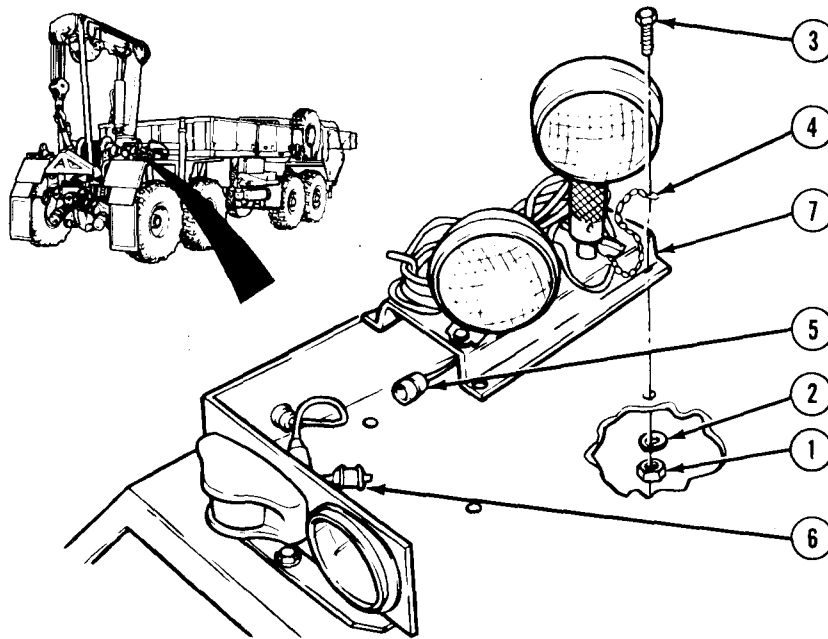
None

General Safety Instructions

None

Electrical System Maintenance Instructions (Cont)

a. Removal.

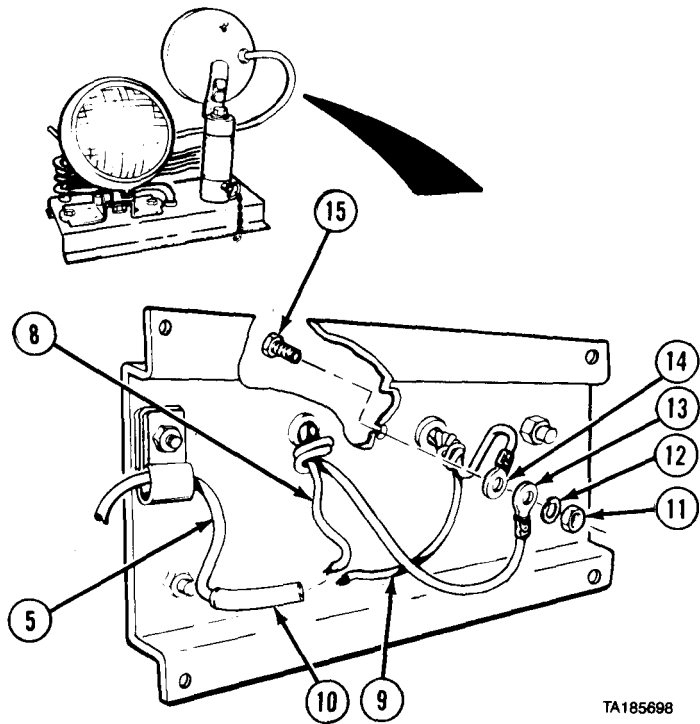


TA185697

NOTE

Tag and mark wires before removing.

- (1) Remove four nuts (1), lockwashers (2), screws (3), and chain (4).
- (2) Remove wire (5) from connector (6) and remove bracket (7).
- (3) Cut two wires (8 and 9) from wire (5) at butt connector (10).
- (4) Remove nut (11), lockwasher (12), two wires (13 and 14), and screw (15). Untie knots in wires (8 and 13) and (9 and 14).

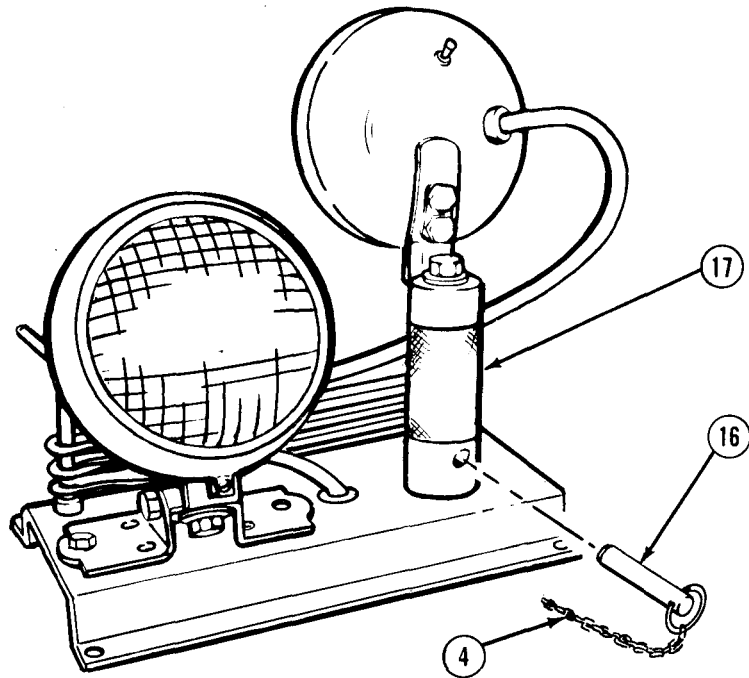


TA185698

Electrical System Maintenance Instructions (Cont)

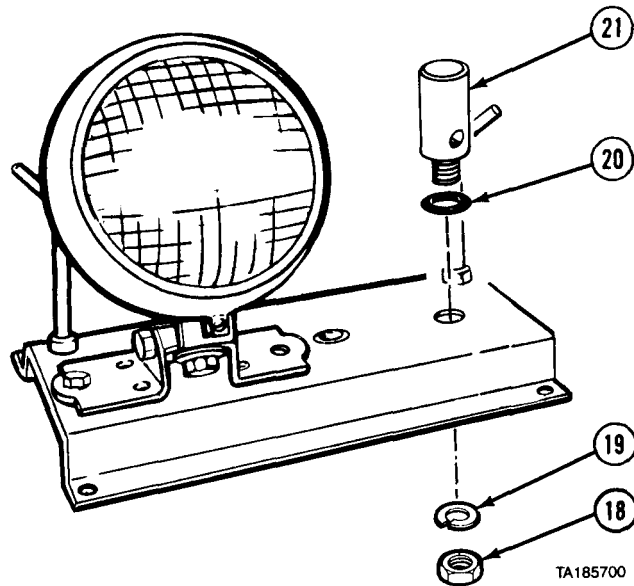
7-72. WORK LAMPS AND BRACKET REMOVAL/INSTALLATION (M984) (CONT).

- (5) Remove pin (16) and removable work lamp (17).
- (6) Remove chain (4) from pin (16).



TA185699

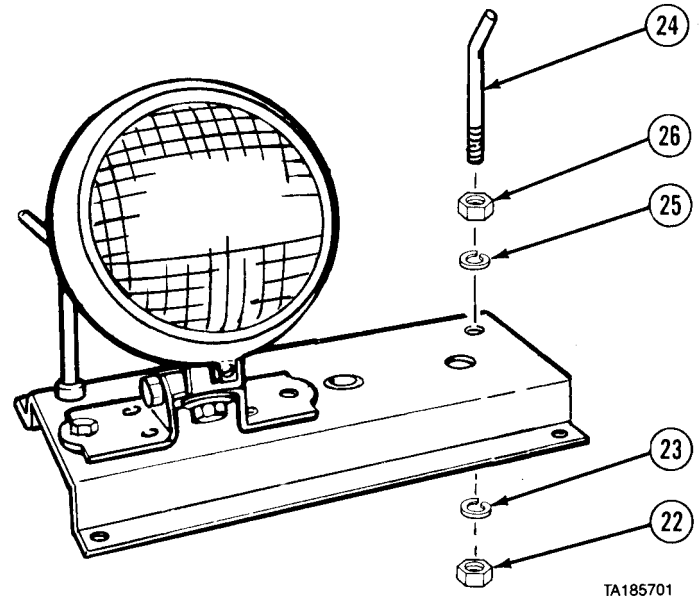
- (7) Remove nut (18), lockwasher (19), preformed packing (20), and mounting stud (21).



TA185700

Electrical System Maintenance Instructions (Cont)

- (8) Remove two nuts (22) and lockwashers (23). Remove two hooks (24), lockwashers (25), and nuts (26).

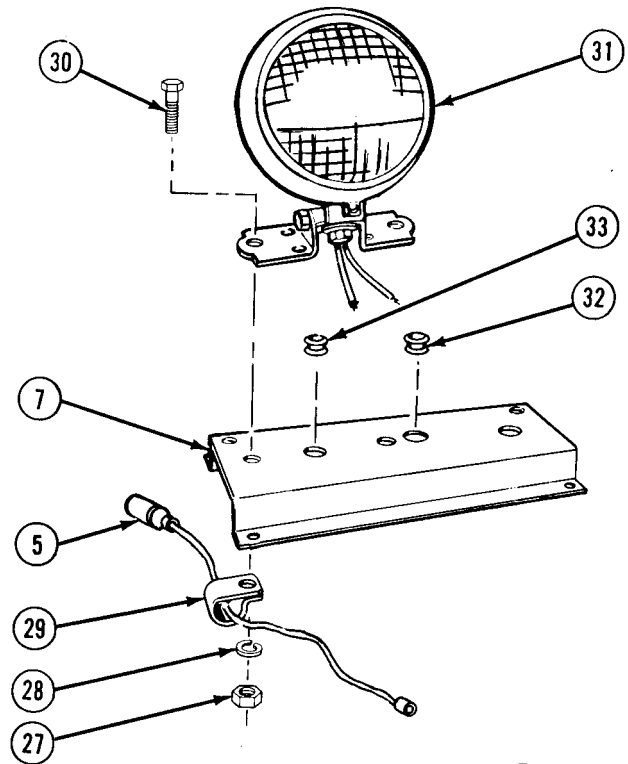


TA185701

NOTE

Wire terminal must be cut off before work lamp can be removed.

- (9) Remove nut (27), lockwasher (28), cushion clip (29), screw (30), and work lamp (31). Remove wire (5) from cushion clip.
- (10) Remove two grommets (32 and 33) from bracket (7).



TA185702

Electrical System Maintenance Instructions (Cont)

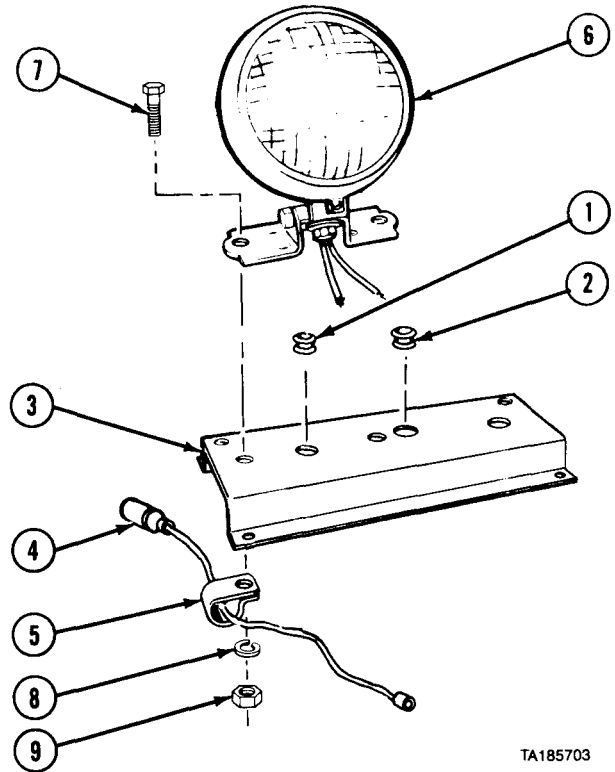
7-72. WORK LAMPS AND BRACKET REMOVAL/INSTALLATION (M984) (CONT).

b. Installation.

NOTE

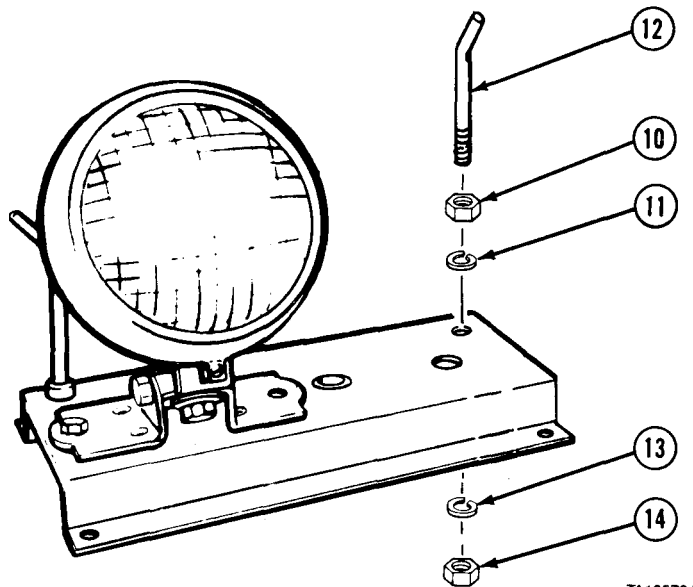
Wire terminal must be installed after wires are threaded through grommet.

- (1) Install two grommets (1 and 2) in bracket (3).
- (2) Install wire (4) in cushion clip (5). Install work lamp (6) and cushion clip with screw (7), lockwasher (8), and nut (9).



TA185703

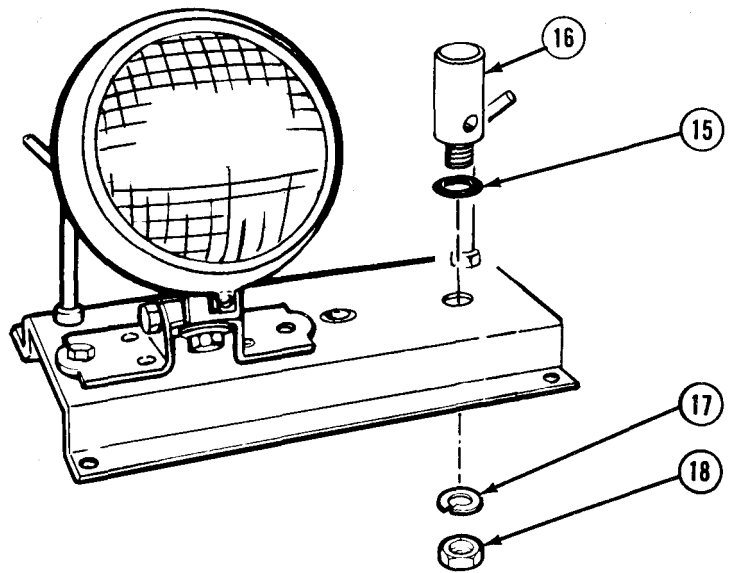
- (3) Install two nuts (10) and lockwashers (11) on hooks (12). Install two hooks with two lockwashers (13) and nuts (14).



TA185704

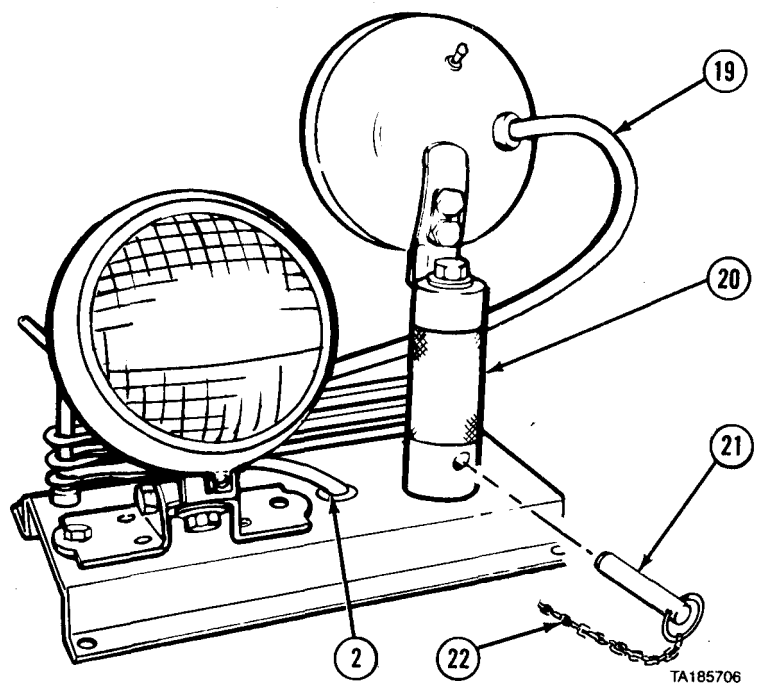
Electrical System Maintenance Instructions (Cont)

- (4) Install preformed packing (15) and mounting stud (16) with lockwasher (17) and nut (18).



TA185705

- (5) Push 6 in. (152 mm) of cable (19) through grommet (2) and install work lamp (20) with pin (21).
 (6) Attach chain (22) to pin (21).

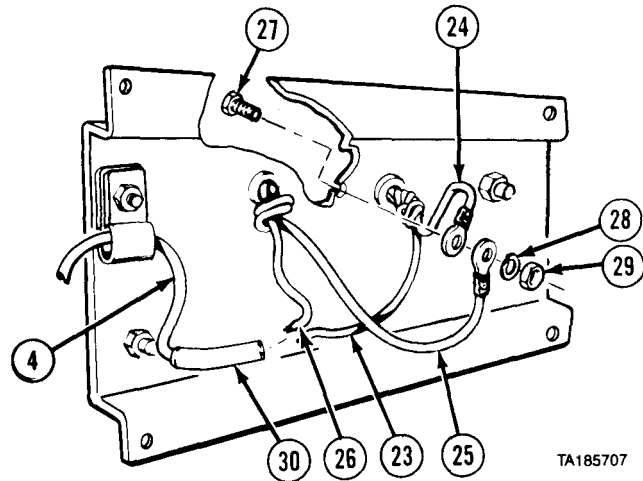


TA185706

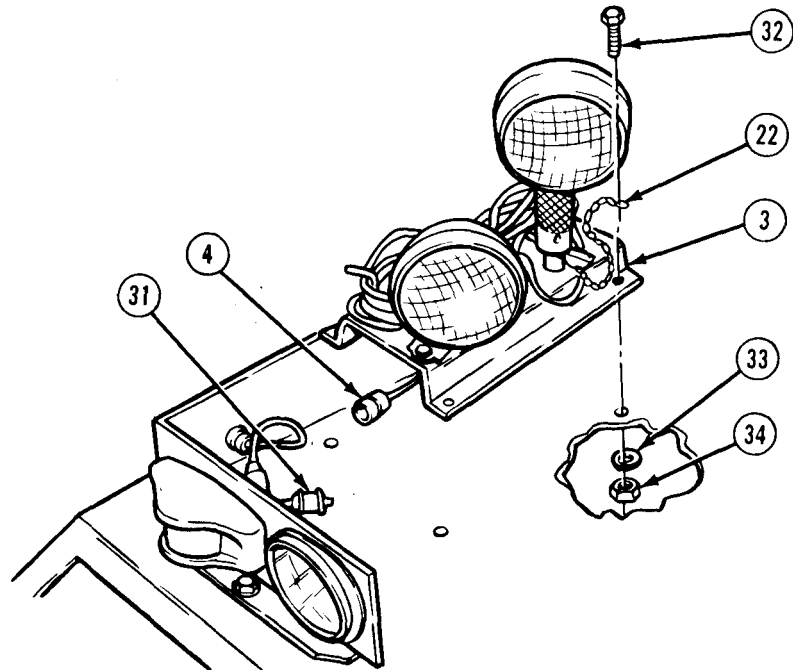
Electrical System Maintenance Instructions (Cont)

7-72. WORK LAMPS AND BRACKET REMOVAL/INSTALLATION (M984) (CONT).

- (7) Tie knots in wires (23 and 24) and (25 and 26).
- (8) Install screw (27) and two wires (24 and 25) with lockwasher (28) and nut (29).
- (9) Connect wire (4) to wires (23 and 26) using butt connector (30).



- (10) Connect wire (4) at connector (31).
 - (11) Install bracket (3) and chain (22) with four screws (32), lockwashers (33), and nuts (34).
- c. *Follow-on Maintenance.*
- (1) Connect batteries (para 7-91).
 - (2) Check operation of work lamps (TM 9-2320-354-10).



END OF TASK

Electrical System Maintenance Instructions (Cont)

7-72.1. FIXED WORKLAMPS REMOVAL/INSTALLATION (M984E1).

This task covers:

- a. Removal
- b. Installation

c. Follow-on Maintenance

INITIAL SETUP

Models

M984E1

Test Equipment

None

Special Tools

None

Supplies

None

Personnel Required

MOS 63S, Heavy wheel vehicle mechanic

References

None

Equipment Condition

TM or Para

Para 7-91

Condition Description

Batteries disconnected.

Special Environmental Conditions

None

General Safety Instructions

None

a. Removal.

NOTE

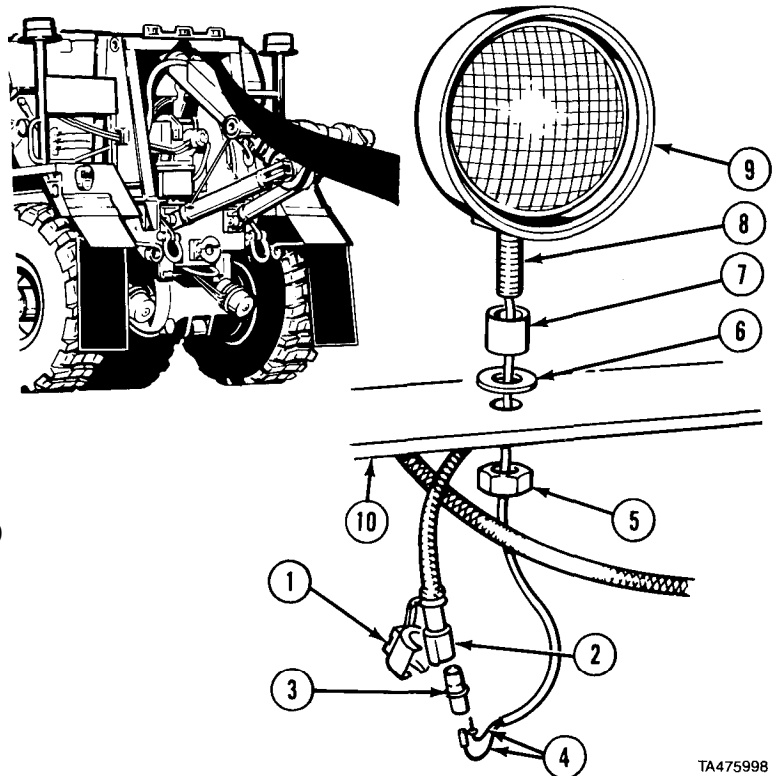
- Left and right worklamps are removed the same way.
- Tag and mark wires before removing.

- (1) Remove clip (1) and disconnect two connectors (2 and 3).
- (2) Remove two wires (4) from connector (3).

NOTE

Mark bushing before removing.

- (3) Remove nut (5), washer (6), and bushing (7) from screw (8).
- (4) Remove worklamp (9) and wires (4) from bracket (10).

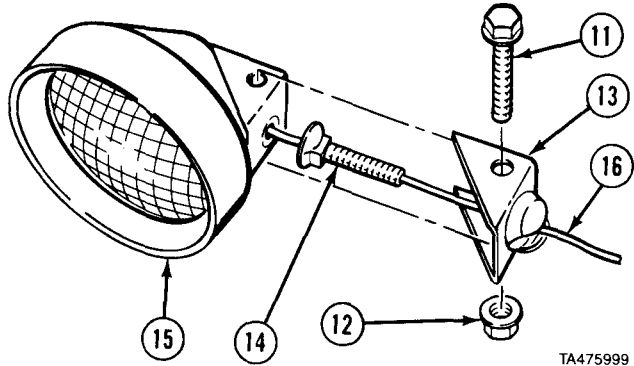


TA475998

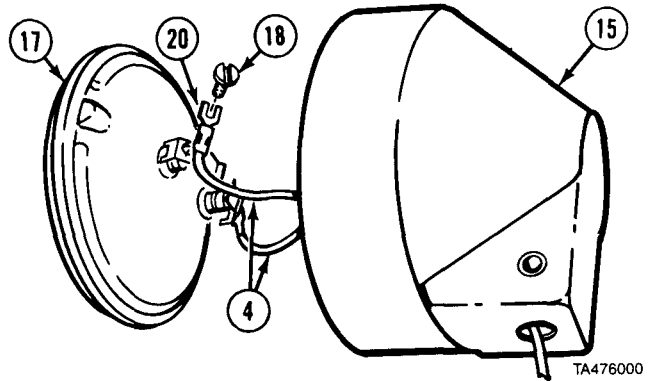
Electrical System Maintenance Instructions (Cont)

7-72.1. FIXED WORKLAMPS REMOVAL/INSTALLATION (M984E1) (CONT).

- (5) Remove screw (11), nut (12), bracket (13), and screw (14) from lamp housing (15) and wire harness (16).

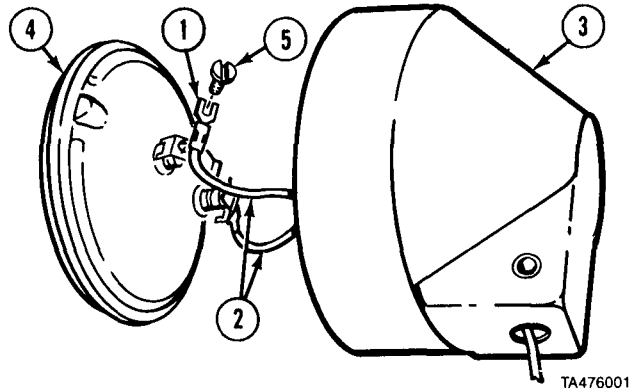


- (6) Remove lamp (17) and two wires (4) from lamp housing (15).
- (7) Remove two screws (18) and two wires (4) from lamp (17).
- (8) Remove two wire terminals (20) from wires (4).

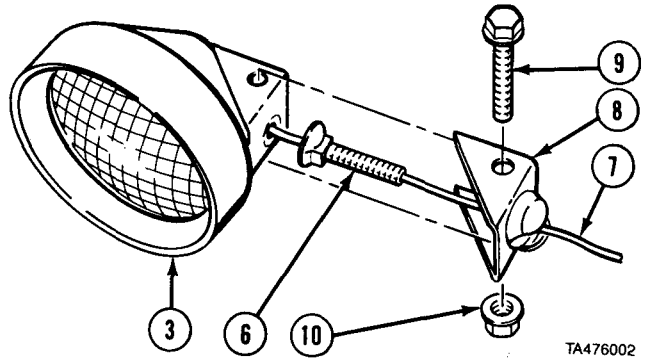


b. Installation.

- (1) Install two wire terminals (1) on wires (2).
- (2) Install two wires (2) in lamp housing (3) on lamp (4) with screws (5).
- (3) Install lamp (4) in lamp housing (3).

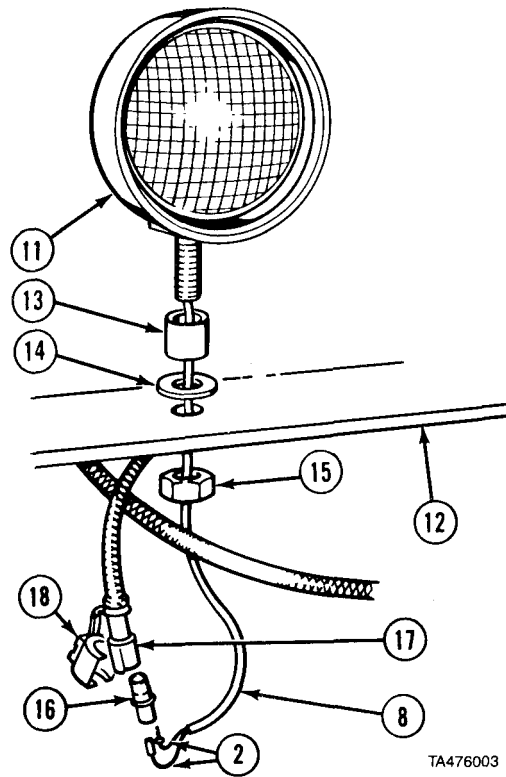


- (4) Install screw (6) and bracket (7) on wiring harness (8) and lamp housing (3) with screw (9) and nut (10).



Electrical System Maintenance Instructions (Cont)

- (5) Install worklamp (11) and wiring harness (8) on bracket (12) with bushing (13), washer (14), and nut (15).
- (6) Install two wires (2) in connector (16).
- (7) Connect two connectors (16 and 17) and install clip (18).



TA476003

c. *Follow-on Maintenance.*

- (1) Connect batteries (para 7-91).
- (2) Check operation of M984E1 worklamps (TM 9-2320-279-10).

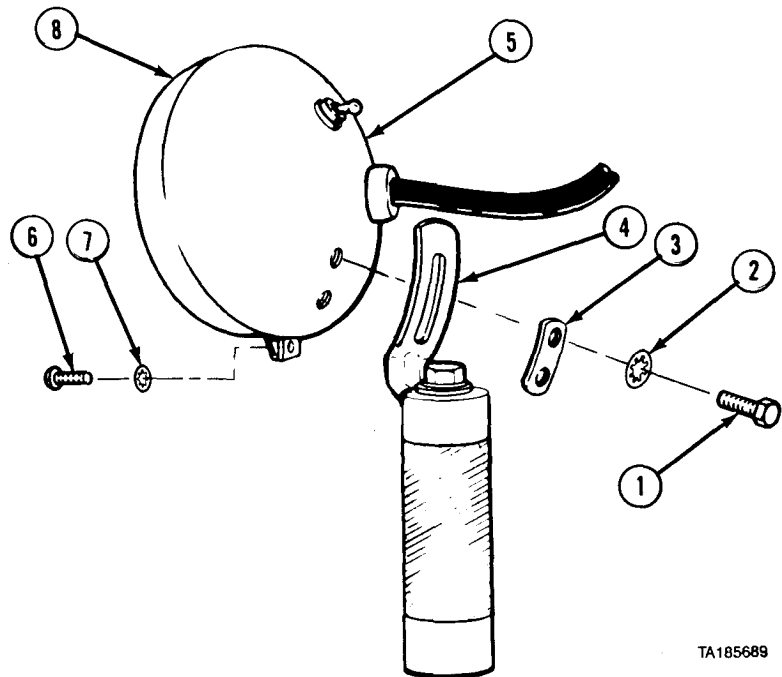
END OF TASK

Electrical System Maintenance Instructions (Cont)

| | |
|---|--|
| 7-73. WORK LAMPS REPAIR (M983, M984). | |
| This task covers: | |
| a. Removable Work Lamp Disassembly | d. Fixed Work Lamp Assembly |
| b. Removable Work Lamp Assembly | e. Follow-on Maintenance |
| c. Fixed Work Lamp Disassembly | |
| INITIAL SETUP | |
| <i>Models</i> | <i>References</i> |
| M983, M984 | None |
| <i>Test Equipment</i> | <i>Equipment Condition</i> |
| None | <i>TM or Para</i> <i>Condition Description</i> |
| <i>Special Tools</i> | TM 9-2320-279-10 Shut off engine. |
| None | Para 7-91 Batteries disconnected. |
| <i>Supplies</i> | <i>Special Environmental Conditions</i> |
| Tape, insulation, electrical, Item 50, Appendix C | None |
| Tags, identification, Item 48, Appendix C | <i>General Safety Instructions</i> |
| <i>Personnel Required</i> | None |
| MOS 63S, Heavy wheel vehicle mechanic | |

a. Removable Work Lamp Disassembly.

- (1) Remove two screws (1), lockwashers (2), plate (3), and bracket (4) from rear housing (5).
- (2) Remove screw (6), lockwasher (7), and front housing (8) from rear housing (5).



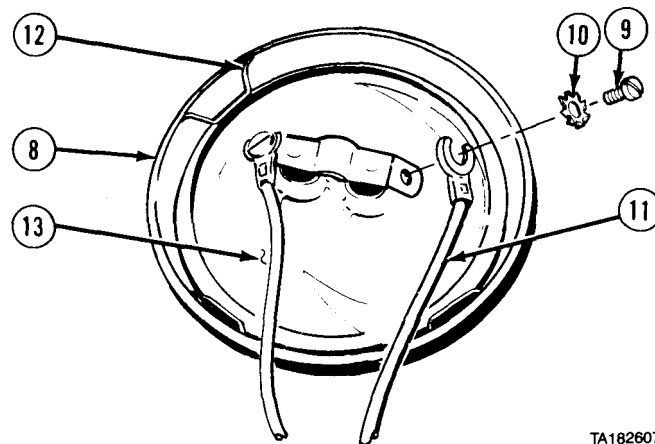
TA185689

Electrical System Maintenance Instructions (Cont)

7-73. WORK LAMPS REPAIR (M983, M984) (CONT).

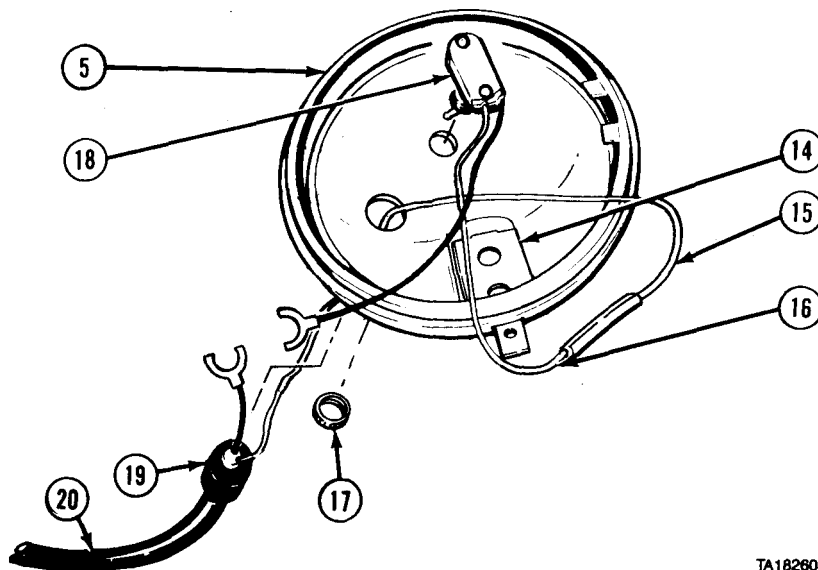
NOTE

- Tag and mark wires before removing.
 - Lockwashers may stay with screws.
- (3) Remove two screws (9), lockwashers (10), and wires (11).
- (4) Remove four retaining springs (12) and lamp (13) from front housing (8).



TA182607

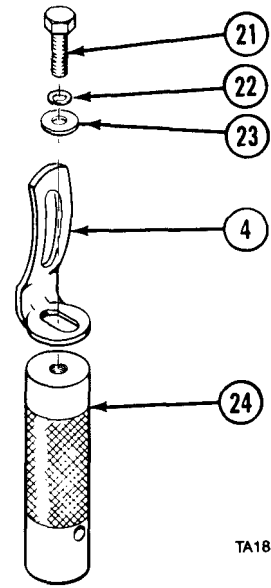
- (5) Remove bracket (14) from rear housing (5).
- (6) Disconnect wire (15) from wire (16).
- (7) Remove nut (17) and switch (18) from rear housing (5).
- (8) Remove bushing (19) and cable (20).



TA182603

Electrical System Maintenance Instructions (Cont)

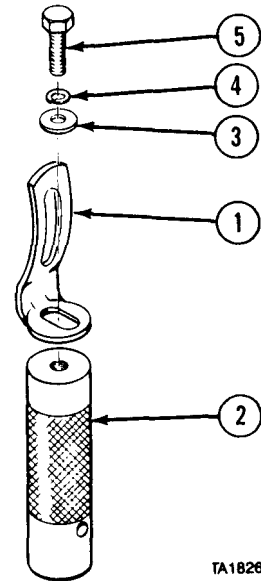
(9) Remove screw (21), lockwasher (22), washer (23), and bracket (4) from handle (24).



TA182604

b. Removable Work Lamp Assembly.

(1) Install bracket (1) on handle (2) with washer (3), lockwasher (4), and screw (5).

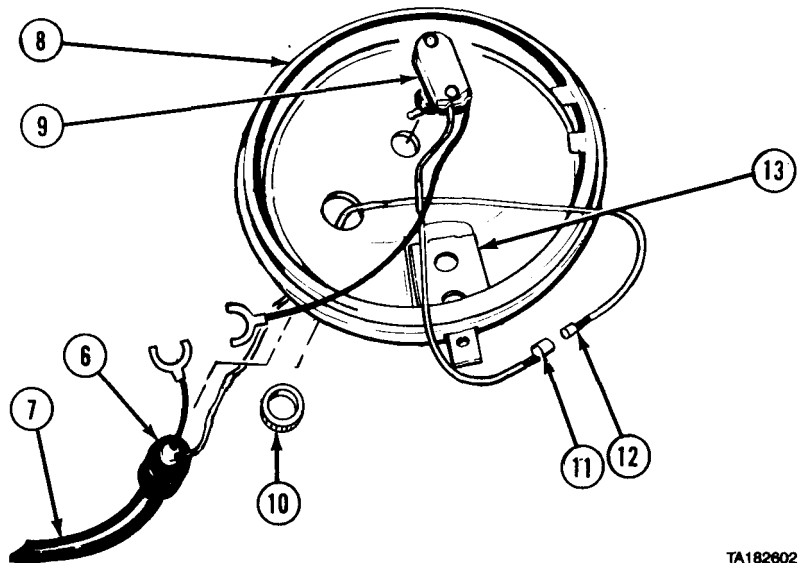


TA182605

Electrical System Maintenance Instructions (Cont)

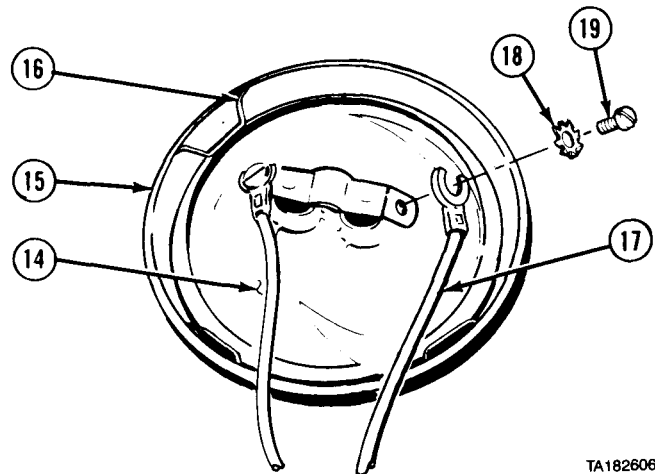
7-73. WORK LAMPS REPAIR (M983, M984) (CONT).

- (2) Install bushing (6) on cable (7) and install bushing in rear housing (8).
- (3) Install switch (9) in rear housing (8) with nut (10).
- (4) Connect wire (11) and wire (12). Wrap wires with electrical tape.
- (5) Install bracket (13) in rear housing (8).



TA182602

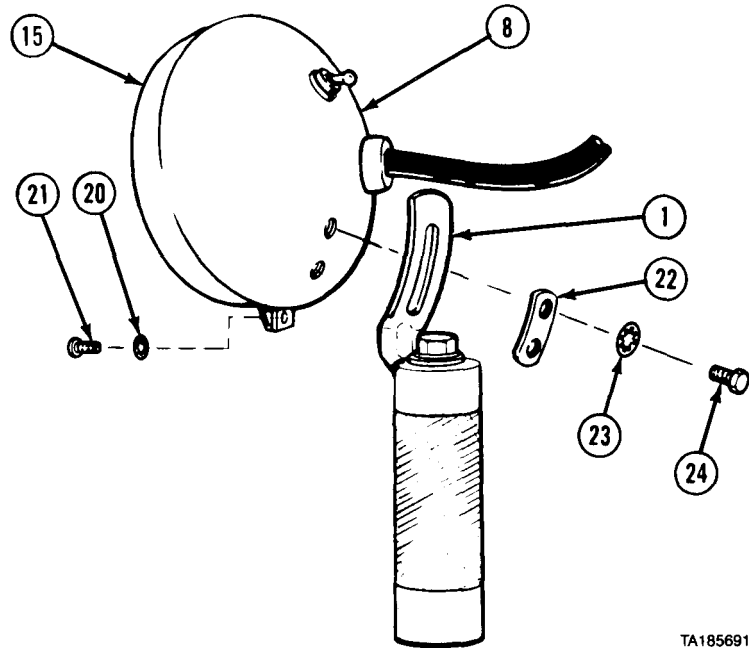
- (6) Install lamp (14) in front housing (15) with four retaining springs (16).
- (7) Install two wires (17) with lockwashers (18) and screws (19).



TA182606

Electrical System Maintenance Instructions (Cont)

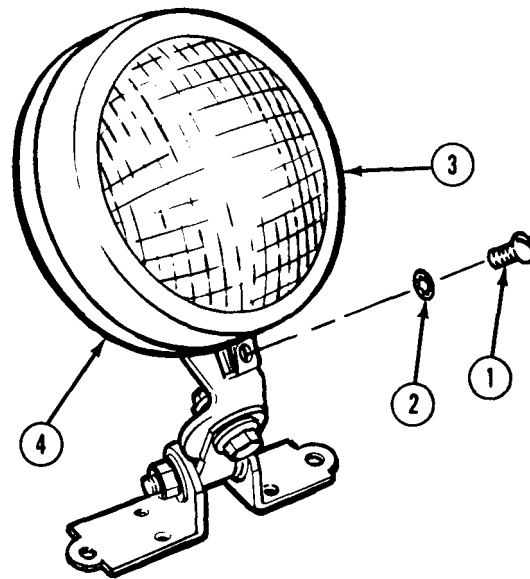
- (8) Install front housing (15) on rear housing (8) with lockwasher (20) and screw (21).
- (9) Install bracket (1) and plate (22) on rear housing (8) with two lockwashers (23) and screws (24).



TA185691

c. Fixed Work Lamp Disassembly.

- (1) Remove screw (1), lockwasher (2), and front housing (3) from rear housing (4).



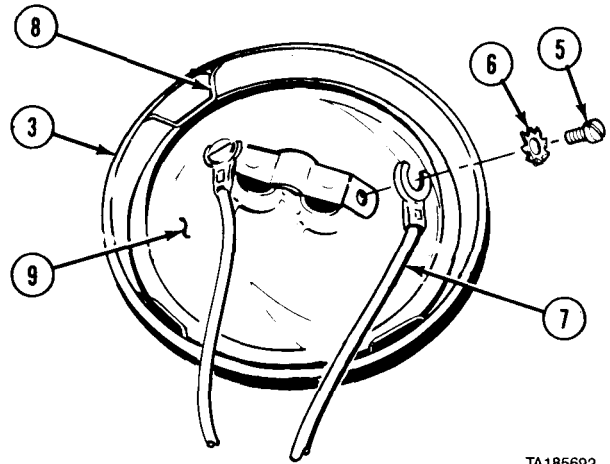
TA185690

Electrical System Maintenance Instructions (Cont)

7-73. WORK LAMPS REPAIR (M983, M984) (CONT).

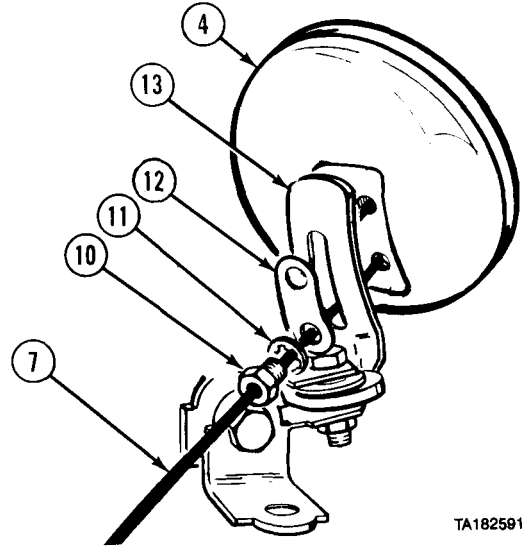
NOTE

- Tag and mark wires before removing.
 - Lockwashers may stay with screws.
- (2) Remove two screws (5), lockwashers (6), and wires (7).
 - (3) Remove four retaining springs (8) and lamp (9) from front housing (3).



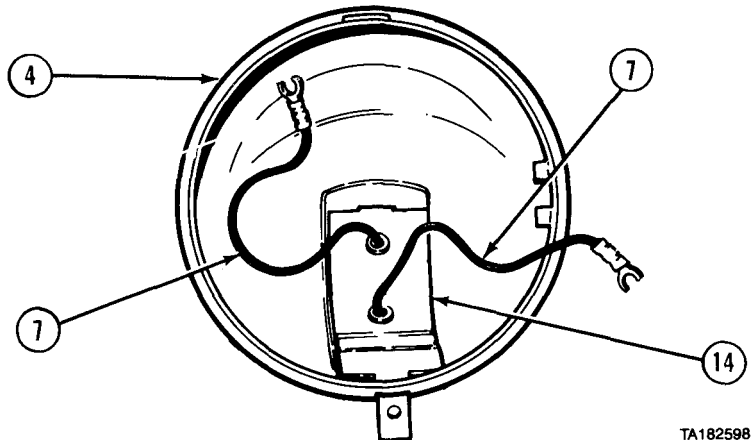
TA185692

- (4) Remove two screws (10), lockwashers (11), and plate (12) from bracket (13), rear housing (4), and two wires (7).



TA182591

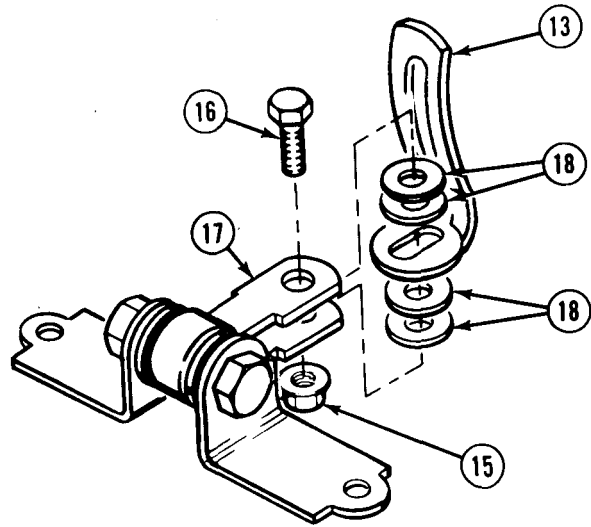
- (5) Remove bracket (14) and two wires (7) from rear housing (4).



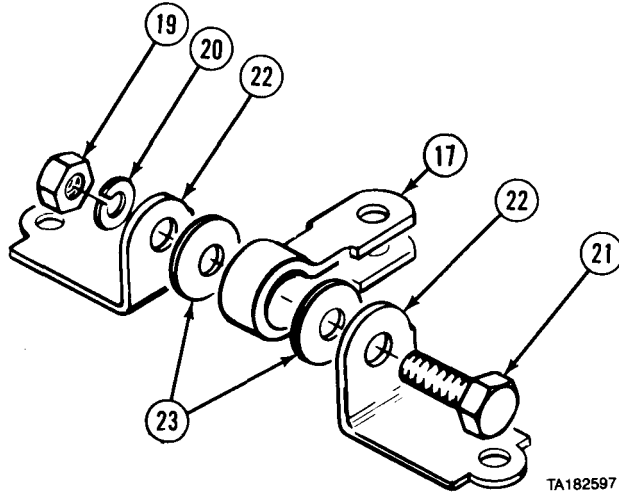
TA182598

Electrical System Maintenance Instructions (Cont)

- (6) Remove locknut (15) and screw (16) from clevis (17).
- (7) Remove bracket (13) and four fiber washers (18).

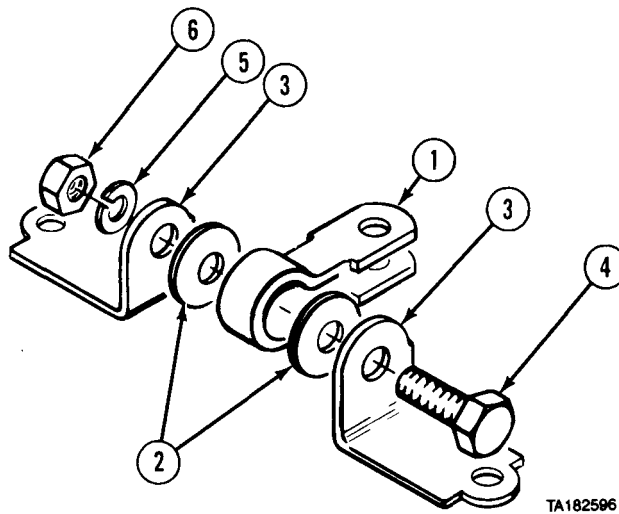


- (8) Remove nut (19), lockwasher (20), and screw (21) from clevis (17) and two mounting brackets (22).
- (9) Remove clevis (17) and two fiber washers (23).



d. Fixed Work Lamp Assembly.

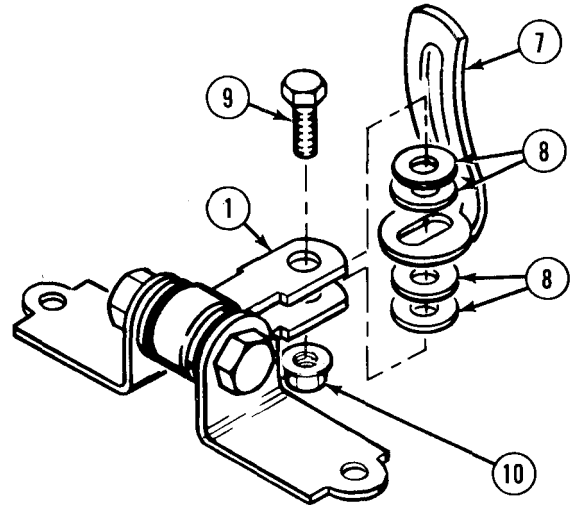
- (1) Install clevis (1) and two fiber washers (2) in mounting brackets (3) with screw (4), lockwasher (5), and nut (6).



Electrical System Maintenance Instructions (Cont)

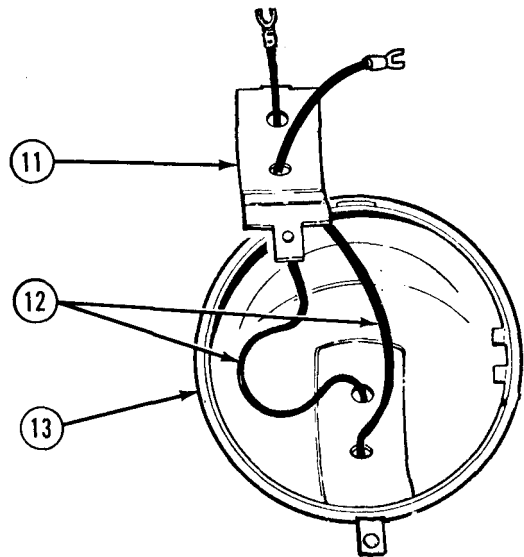
7-73. WORK LAMPS REPAIR (M983, M984) (CONT).

(2) Install bracket (7) and four fiber washers (8) on clevis (1) with screw (9) and locknut (10).



TA182593

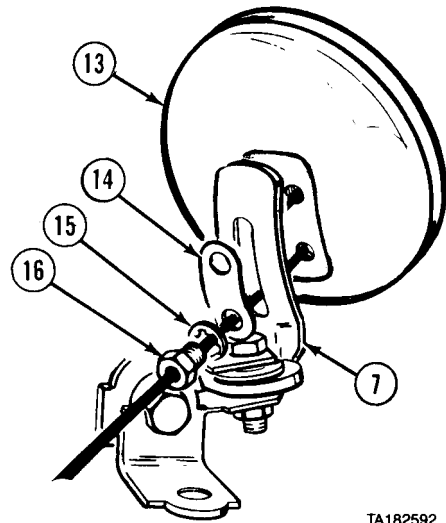
(3) Install bracket (11) and two wires (12) in rear housing (13).



TA182595

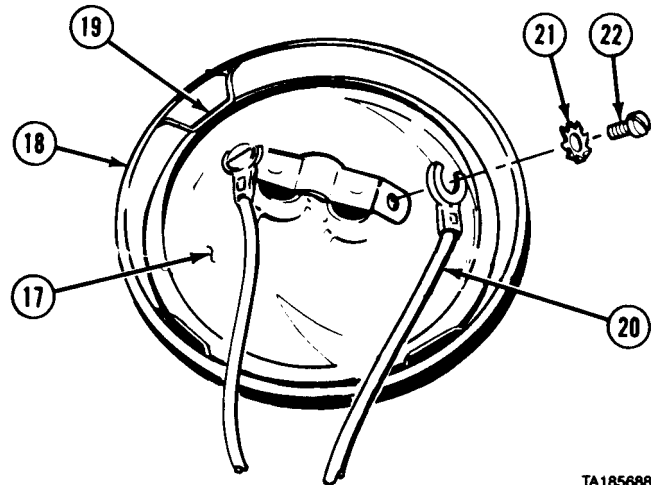
Electrical System Maintenance Instructions (Cont)

- (4) Install rear housing (13) and plate (14) on bracket (7) with two lockwashers (15) and screws (16).



TA182592

- (5) Install lamp (17) in front housing (18) with four retaining springs (19).
 (6) Install two wires (20) with two lockwashers (21) and screws (22).



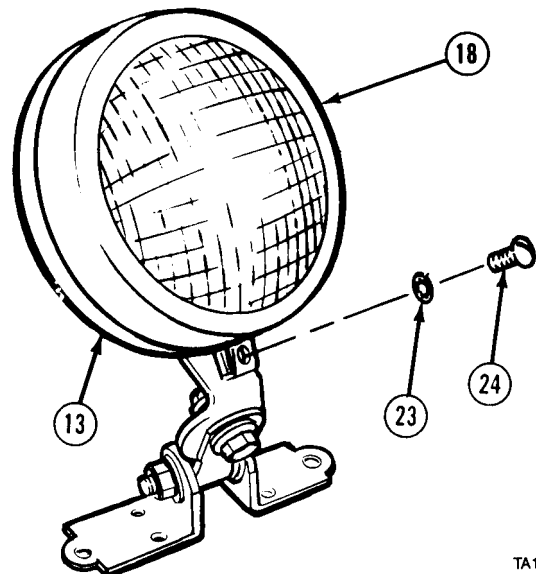
TA185688

- (7) Install front housing (18) on rear housing (13) with lockwasher (23) and screw (24).

e. Follow-on Maintenance.

- (1) Connect batteries (para 7-91).
 (2) Check operation of work lamps (M983) (TM 9-2320-279-10).
 (3) Check operation of work lamps (M984) (TM 9-2320-354-10).

END OF TASK

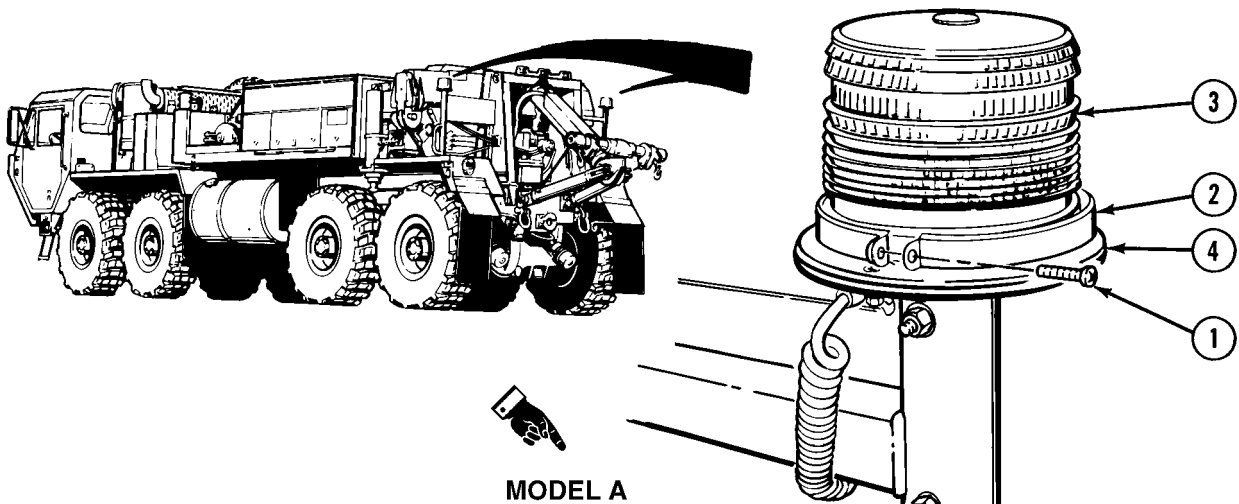


TA185693

Electrical System Maintenance Instructions (Cont)

| | |
|---|--|
| 7-73.1. BEACON LIGHT ASSEMBLY REMOVAL/REPAIR/INSTALLATION (MODELS A, B, AND C) (M984E1). | |
| This task covers: | |
| a. Removal b. Installation | c. Follow-on Maintenance |
| INITIAL SETUP | |
| <i>Models</i> M984E1 | <i>References</i> None |
| <i>Test Equipment</i> None | <i>Equipment Condition</i> <i>TM or Para</i> Para 7-91 |
| <i>Special Tools</i> None | <i>Condition Description</i> Batteries disconnected. |
| <i>Supplies</i> None | <i>Special Environmental Conditions</i> None |
| <i>Personnel Required</i> MOS 63S, heavy wheel vehicle mechanic | <i>General Safety Instructions</i> None |

a. Removal



MODEL A

NOTE

- Left and right beacon light assemblies are removed the same way.
- There are three models of beacon lights. Model A uses a clamp to secure the light. Model B and Model C each use a collar and screws. Perform step (1) for Model A. Perform steps (1.1) through (1.3) for Model B and Model C.

(1) Remove screw (1), clamp (2), and lens (3) from beacon light assembly (4).

Engine Maintenance Instructions (Cont)

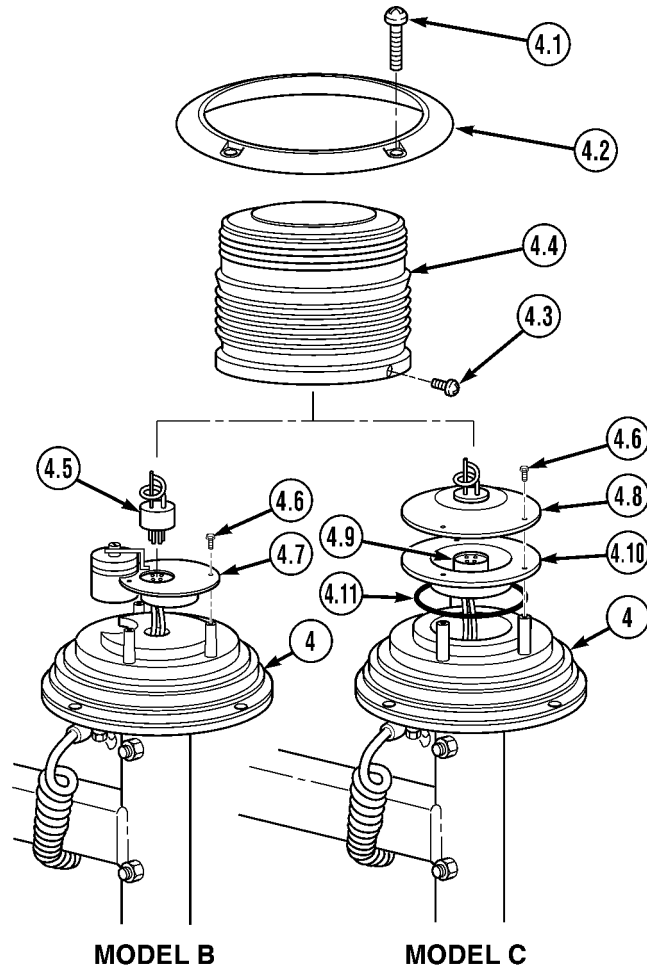
7-73.1. BEACON LIGHT ASSEMBLY REMOVAL/REPAIR/INSTALLATION (MODELS A, B, AND C) (M984E1) (CONT).

- (1.1) Remove three screws (4.1), collar (4.2), two screws (4.3), and lens (4.4) from beacon light assembly (4).
- (1.2) Remove flashtube lamp (4.5) from Model B beacon light assembly (4).
- (1.3) Remove three screws (4.6) from beacon light assembly (4).

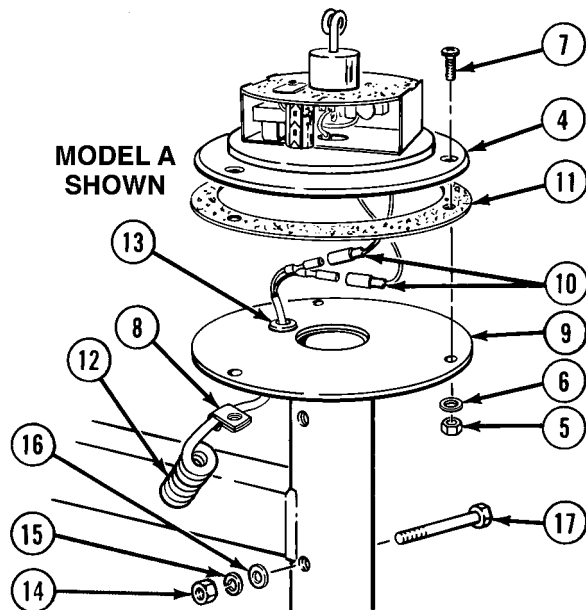
NOTE

- Model B and Model C have removable power supply units. Model C has a seal that is removed with power supply.
- Model C has a plug connection between power supply and flash tube holder assembly.
- Perform step (1.4) for Model B and steps (1.5) and (1.6) for Model C.
- Wires remain connected until step (3).

- (1.4) Remove power supply unit (4.7) from beacon light assembly (4).
- (1.5) Remove flash tube holder assembly (4.8), from plug connection (4.9) and power supply unit (4.10).
- (1.6) Remove power supply unit (4.10) and seal (4.11) from beacon light assembly (4).



- (2) Remove three locknuts (5), washers (6), screws (7), clamp (8), and beacon light assembly (4) from mount (9).
- (3) Disconnect connectors (10) and remove gasket (11), wire (12), and grommet (13) from mount (9).
- (4) Remove clamp (8) from wire (12).
- (5) Remove two nuts (14), lockwashers (15), washers (16), screws (17), and mount (9).

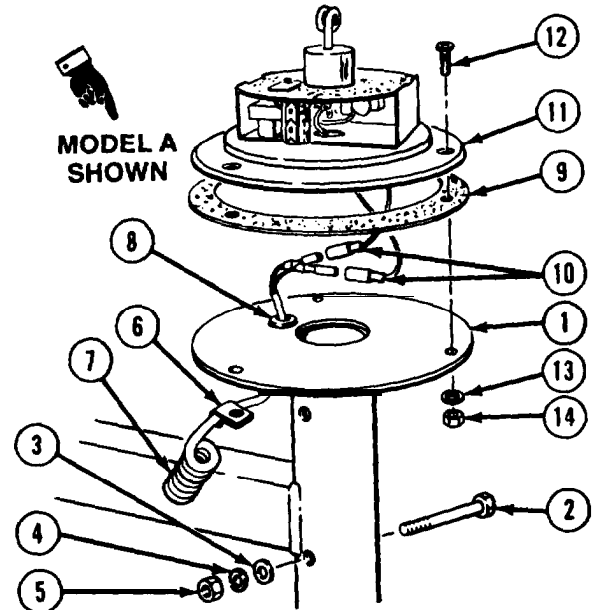


Electrical System Maintenance Instructions (Cont)

b. Installation.

NOTE

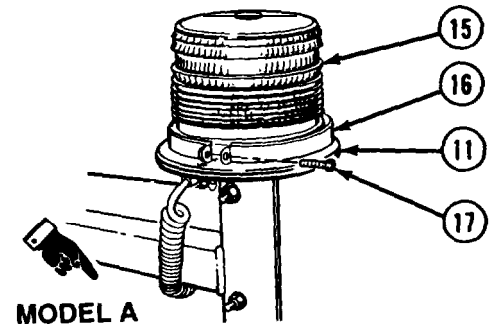
- Left and right beacon light assemblies are installed the same way.
 - Install right side mount so that cutout on bottom faces forward. Left side mount does not have cutout.
- (1) Install mount (1) with two screws (2), washers (3), lockwashers (4), and nuts (5).
 - (2) Install clamp (6) on wire (7).
 - (3) Install grommet (8) and wire (7) in mount (1).
 - (4) Install gasket (9).
 - (5) Connect two connectors (10).
 - (6) Install beacon light assembly (11) and clamp (6) on mount (1) with three screws (12), washers (13), and locknut (14).



NOTE

There are three models of beacon lights. Model A uses a clamp to secure the light. Model B and Model C use a collar and screws. Perform step (7) for Model A.

- (7) Install lens (15) on beacon light assembly (11) with clamp (16) and screw (17).



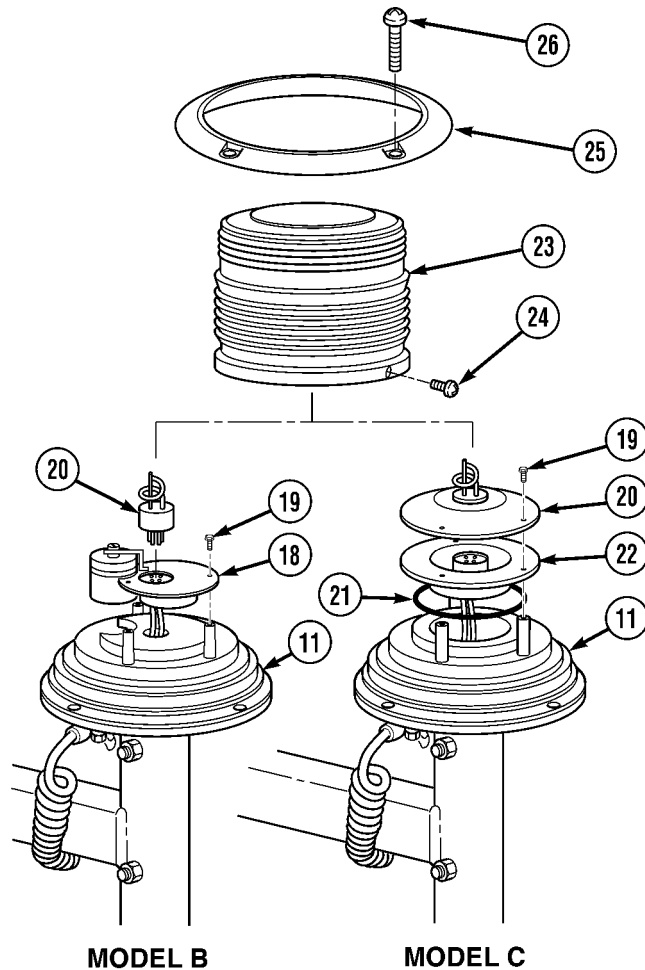
Electrical System Maintenance Instructions (Cont)

7-73.1. BEACON LIGHT ASSEMBLY REMOVAL/REPAIR/INSTALLATION (MODELS A, B, AND C) (M984E1) (CONT).

NOTE

- Model B and Model C have removable power supply unit. Model C has a seal that is installed with power supply unit.
- Model C has a plug connection to be connected between power supply and flash tube holder assembly.
- Perform steps (8) and (9) for Model B only.
- Perform step (10) for Model C.
- Perform steps (11) and (12) for Model B and Model C.

- (8) Install power supply unit (18) on beacon light assembly (11) with three screws (19).
- (9) Install flashtube lamp (20) in power supply unit (18).
- (10) Install seal (21), power supply unit (22) and flash tube holder assembly (20) on beacon light assembly (11) with three screws (19).
- (11) Install lens (23) on beacon light assembly (11) with two screws (24).
- (12) Install collar (25) on beacon light assembly (11) with three screws (26).



c. Follow-on Maintenance.

- (1) Connect batteries (para 7-91).
- (2) Check M984E1 beacon light operation (TM 9-2320-279-10).

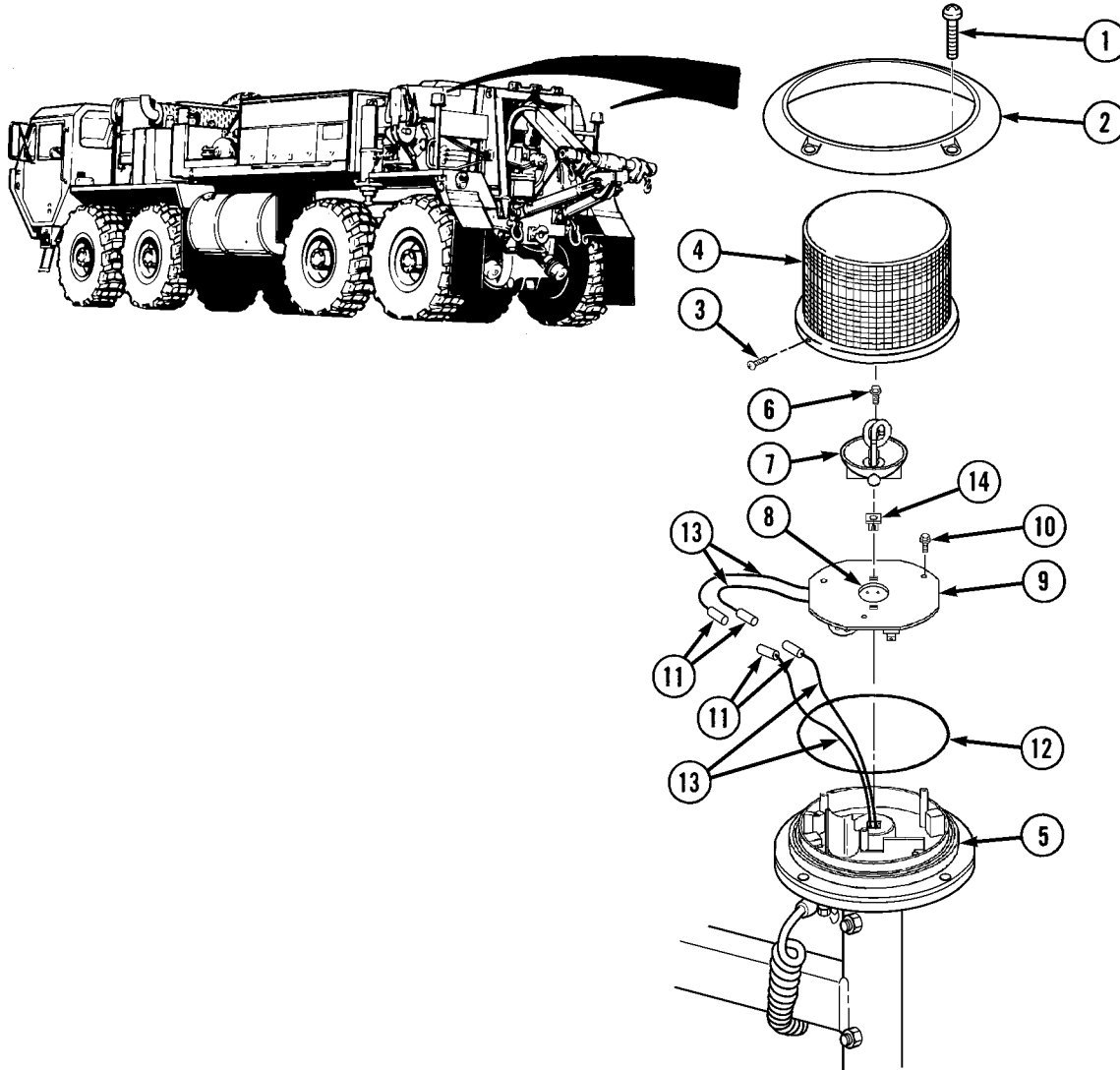
END OF TASK

Electrical System Maintenance Instructions (Cont)

| | |
|---|--|
| 7-73.1.1 BEACON LIGHT ASSEMBLY REMOVAL/REPAIR/INSTALLATION MODEL D (M984E1). | |
| This task covers: | |
| a. Removal b. Installation | c. Follow-on Maintenance |
| INITIAL SETUP | |
| <i>Models</i> M984E1 | <i>References</i> None |
| <i>Test Equipment</i> None | <i>Equipment Condition</i> <i>TM or Para</i> Para 7-91 |
| <i>Special Tools</i> None | <i>Condition Description</i> Batteries disconnected. |
| <i>Supplies</i> None | <i>Special Environmental Conditions</i> None |
| <i>Personnel Required</i> MOS 63S, heavy wheel vehicle mechanic | <i>General Safety Instructions</i> None |

Electrical System Maintenance Instructions (Cont)

7-73.1.1 BEACON LIGHT ASSEMBLY REMOVAL/REPAIR/INSTALLATION MODEL D (M984E1) (CONT).



a. Removal.

NOTE

Left and right beacon light assemblies are removed the same way.

- (1) Remove three screws (1), collar (2), two screws (3), and lens (4) from beacon light assembly (5).
- (2) Remove two screws (6) and flash tube assembly (7) from plug connection (8) and power supply (9).
- (3) Remove three screws (10) from power supply (9), disconnect four connectors (11) and remove power supply and preformed packing (12) from beacon light assembly (5).

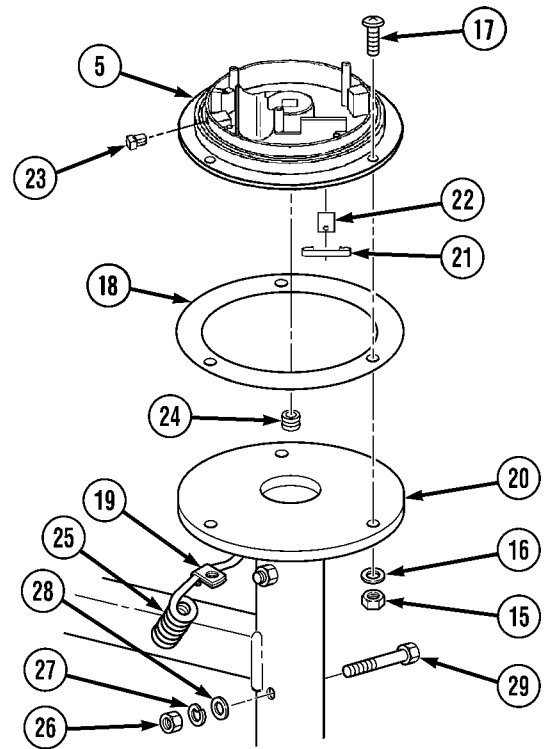
NOTE

Tag and mark wires prior to removal.

- (4) Remove four connectors (11) from wires (13).
- (5) Remove two grommets (14) from power supply (9).

Electrical System Maintenance Instructions (Cont)

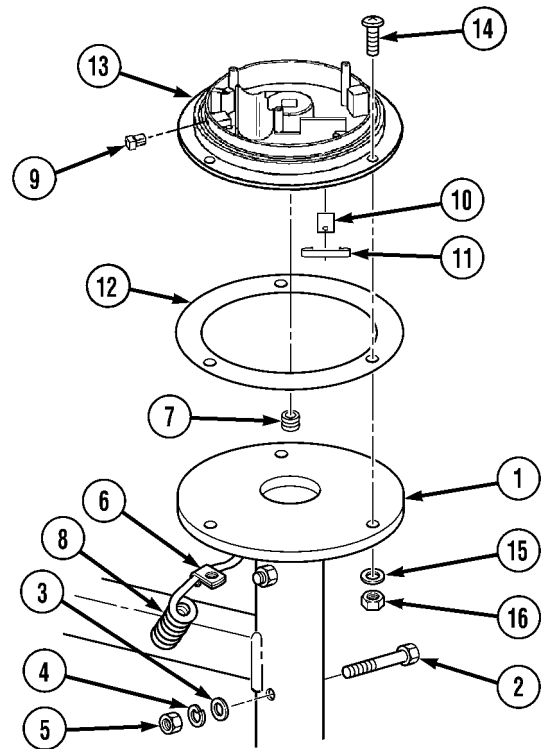
- (6) Remove three locknuts (15), washers (16), screws (17), gasket (18), clamp (19), and beacon light assembly (5) from mount (20).
- (7) Remove spring clip (21), insulator (22), grommet (23), and grommet (24) from beacon light assembly (5).
- (8) Remove grommet (24) and clamp (19) from wire (25).
- (9) Remove two nuts (26), lockwashers (27), washers (28), screws (29), and mount (20).



b. Installation.

NOTE

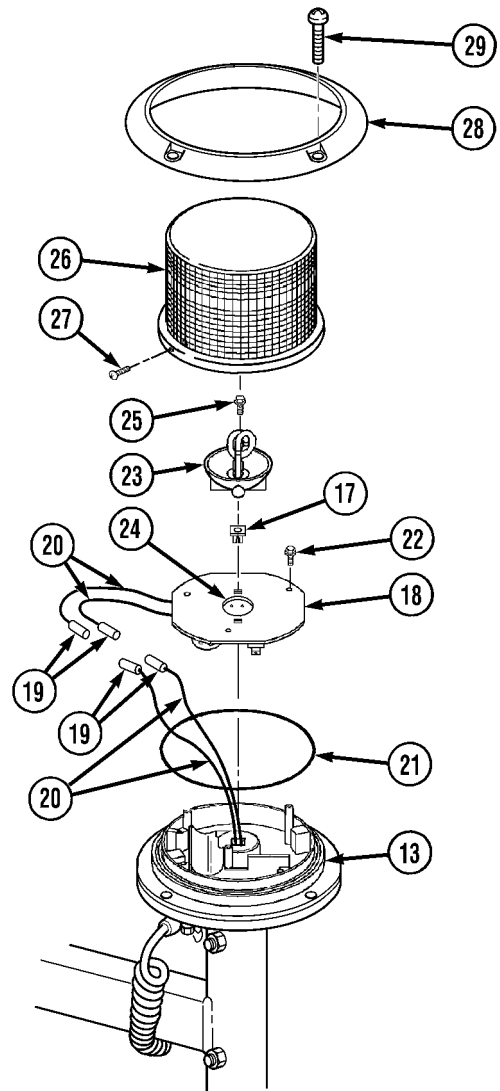
- Left and right beacon light assemblies are installed the same way.
 - Install right side mount so that cutout on bottom faces forward. Left side mount does not have cutout.
- (1) Install mount (1) with two screws (2), washers (3), lockwashers (4), and nuts (5).
 - (2) Install clamp (6) and grommet (7) on wire (8).
 - (3) Install grommet (9), insulator (10), spring clip (11), grommet (7), and gasket (12) on beacon light assembly (13).
 - (4) Install clamp (6) and beacon light assembly (13) on mount (1) with three screws (14), washers (15), and locknuts (16).



Electrical System Maintenance Instructions (Cont)

7-73.1.1 BEACON LIGHT ASSEMBLY REMOVAL/REPAIR/INSTALLATION MODEL D (M984E1) (CONT).

- (5) Install two grommets (17) on power supply (18).
- (6) Attach four connectors (19) to wires (20).
- (7) Install preformed packing (21) on power supply (18), connect four connectors (19) and install power supply to beacon light assembly (13) with three screws (22).
- (8) Install flash tube assembly (23) on power supply (18) using plug connection (24) and two screws (25).
- (9) Install lens (26) on beacon light assembly (13) with two screws (27), collar (28), and three screws (29).



c. Follow-on Maintenance..

- (1) Connect batteries (para 7-91).
- (2) Check M984E1 beacon light operation (TM 9-2320-279-10).

END OF TASK

Electrical System Maintenance Instructions (Cont)

7-73.2. BEACON LIGHT SUPPORT BRACKETS REMOVAL/INSTALLATION (M984E1).

This task covers:

- | | |
|---------------------------|----------------------------|
| a. Left Side Removal | d. Right Side Installation |
| b. Left Side Installation | e. Follow-on Maintenance |
| c. Right Side Removal | |

INITIAL SETUP

Models

M984E1

Test Equipment

None

Special Tools

None

Supplies

None

Personnel Required

MOS 63S, Heavy wheel vehicle mechanic

References

None

Equipment Condition

TM or Para

Condition Description

Para 7-54.1

Movable worklamp and bracket removed.

Para 7-73.1

Beacon light assembly removed.

Para 17-22

Retriever control assembly removed (left side only).

Para 7-52.1

Control box removed (right side only).

Special Environmental Conditions

None

General Safety Instructions

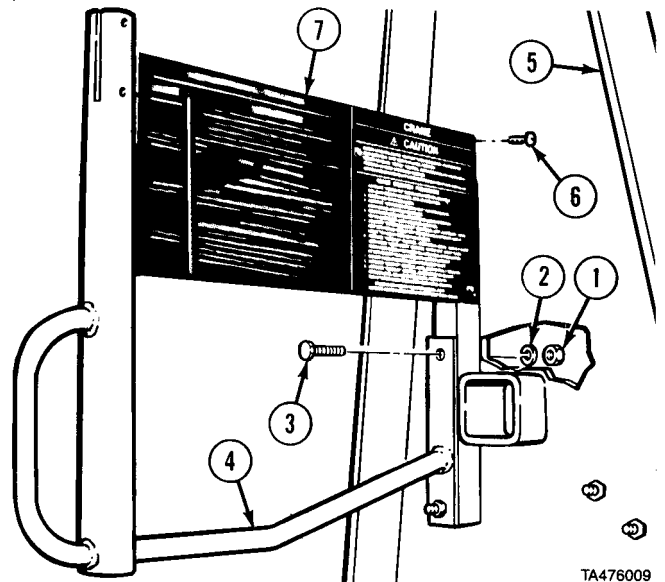
None

a. Left Side Removal.

NOTE

Clips and plastic cable ties are removed as necessary.

- (1) Remove two nuts (1), lockwashers (2), screws (3), and bracket (4) from towing support assembly (5).
 - (2) Remove five screws (6) and data plate (7) from bracket (4).
- b. Left Side Installation.
- (1) Install data plate (7) on bracket (4) with five screws (6).
 - (2) Install bracket (4) on towing support assembly (5) with two screws (3), lockwashers (2), and nuts (1).



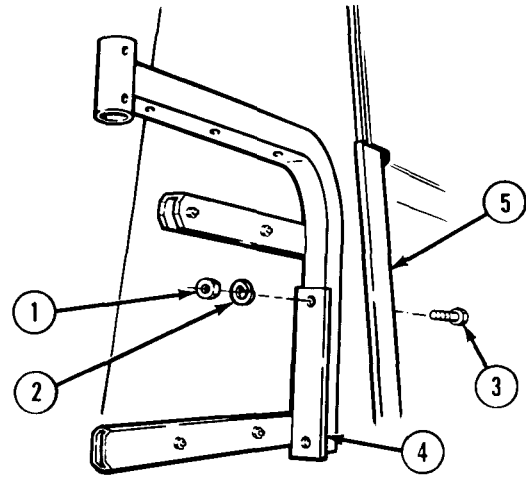
TA476009

Electrical System Maintenance Instructions (Cont)

7-73.2. BEACON LIGHT SUPPORT BRACKETS REMOVAL/INSTALLATION (M984E1).

c. Right Side Removal. Remove two nuts (1), lockwashers (2), screws (3), and bracket (4) from towing support assembly (5).

d. Right Side Installation. Install bracket (4) on towing support assembly (5) with two screws (3), lockwashers (2), and nuts (1).



e. Follow-on Maintenance.

- (1) Install strobe light assembly (para 7-73.1).
- (2) Install moveable worklamp assembly and bracket (para 7-54.1).
- (3) Install control box (para 7-52.1) right side only.
- (4) Install retriever control assembly (para 17-22) left side only.

END OF TASK

7-73.3. TOW LIGHT ASSEMBLY REPAIR (M984E1).

This task covers:

- a. Removal
- b. Installation
- c. Follow-on Maintenance

INITIAL SETUP

Models
M984E1

Test Equipment
None

Special Tools
None

Supplies
Tags, identification, Item 48, Appendix C
Ties, cable, plastic, Item 52, Appendix C

Personnel Required
MOS 63S, Heavy wheel vehicle mechanic

References
None

Equipment Condition
TM or Para *Condition Description*
TM 9-2320-279-10 Tow light assembly removed from stowage box and mounting brackets installed.

Special Environmental Conditions
None

General Safety Instructions
None

NOTE

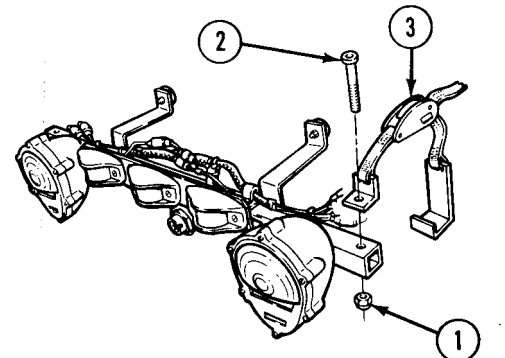
- There are two models of composite lights.
- Model A is a lamp type light.
- Model B is an LED type light with a ground wire pigtail attached.

Electrical System Maintenance Instructions (Cont

7-73.3. TOW LIGHT ASSEMBLY REPAIR (M984E1) (CONT).

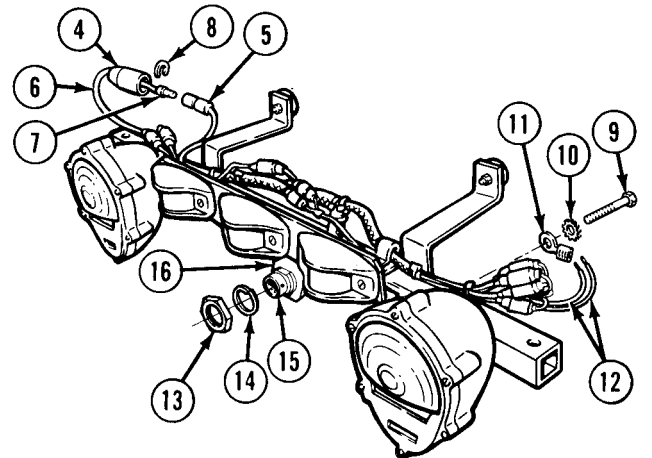
a. Removal.

- (1) Remove two locknuts (1), screws (2), and four emergency straps (3).



TA476021

- Tag and mark wires before removing.
 - Cut plastic cable ties as necessary.
- (2) Disconnect 11 connectors (4) from connectors (5).
 - (3) Push 11 connectors (4) back on wires (6) and remove pins (7) and washers (8).

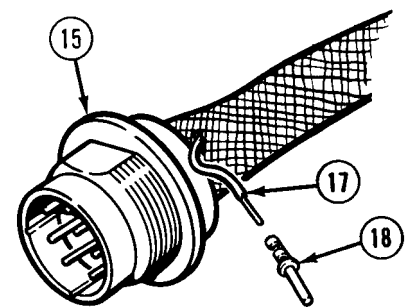


TA476020

NOTE

Mark position of ground wire and screw to aid installation.

- (4) Remove screw (9), lockwasher (10), and connector (11).
- (5) Remove two ground wires (12) from connector (11).
- (6) Remove nut (13), lockwasher (14), and connector (15) from tow light tab (16).
- (7) Remove eight wires (17) from connector (15).
- (8) Remove eight pins (18) from wires (17).

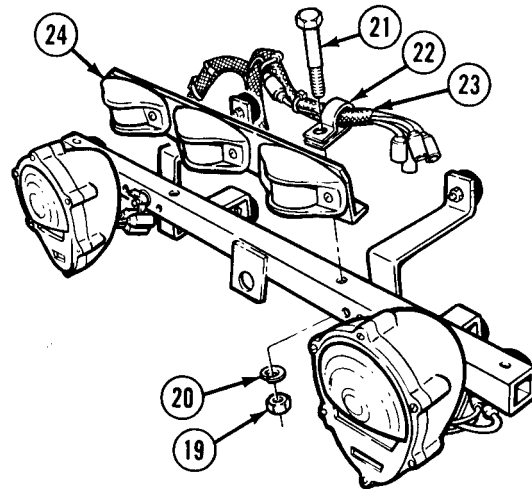


TA476019

Electrical System Maintenance Instructions (Cont)

7-73.3. TOW LIGHT ASSEMBLY REPAIR (M984E1) (CONT).

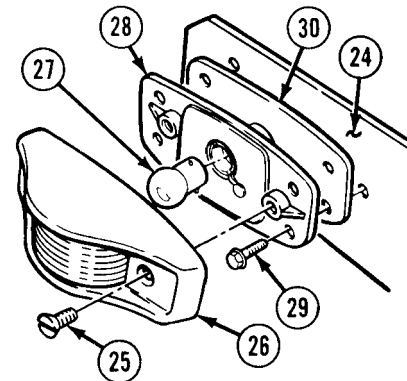
- (9) Remove two nuts (19), lockwashers (20), screws (21), clips (22), wiring harness (23), and clearance light bracket (24).



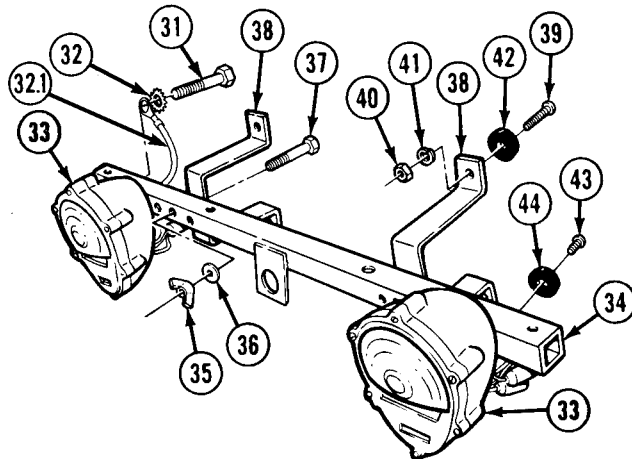
NOTE

All three clearance lights are removed the same way.

- (10) Remove two screws (25), lens (26), and bulb (27) from lampholder (28).
- (11) Remove two screws (29), lampholder (28), and gasket (30) from clearance light bracket (24).



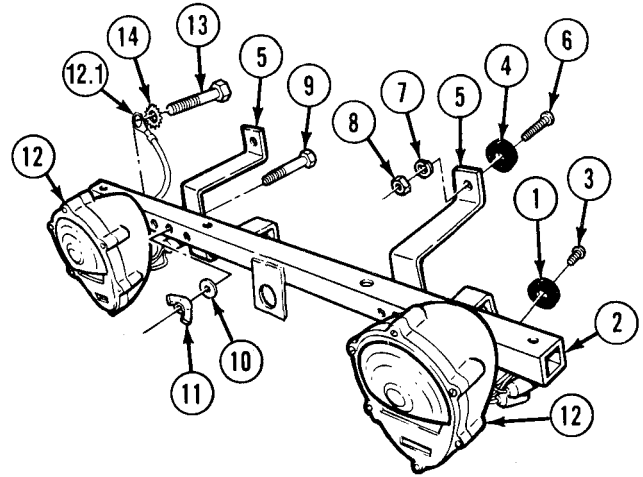
- (12) Remove three screws (31), lockwashers (32), two ground wire pigtails (32.1) (Model B only), and two composite lights (33) from tube (34).
- (13) Remove two wingnuts (35), washers (36), screws (37), and brackets (38) from tube (34).
- (14) Remove four screws (39), nuts (40), lockwashers (41), and bumpers (42) from two brackets (38).
- (15) Remove two screws (43) and bumpers (44) from tube (34).



Electrical System Maintenance Instructions (Cont)

b. Installation.

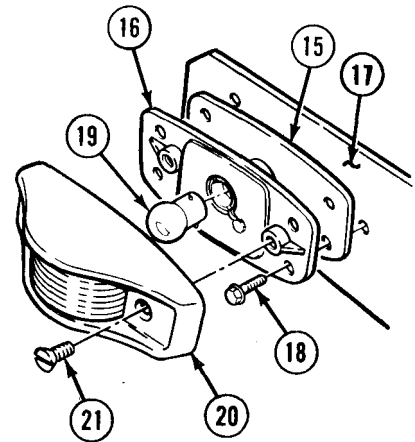
- (1) Install two bumpers (1) on tube (2) with screws (3).
- (2) Install four bumpers (4) on two brackets (5) with four screws (6), lockwashers (7), and nuts (8).
- (3) Install two brackets (5) on tube (2) with screws (9), washers (10), and wingnuts (11).
- (4) Install two composite lights (12) and ground wire pigtails (12.1) (Model B only) on tube (2) with three screws (13) and lockwashers (14).



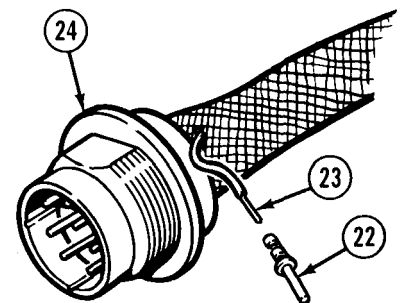
NOTE

All three clearance lights are installed the same way.

- (5) Install gasket (15) and lampholder (16) on clearance light bracket (17) with two screws (18).
- (6) Install bulb (19) and lens (20) in lampholder (16) with two screws (21).

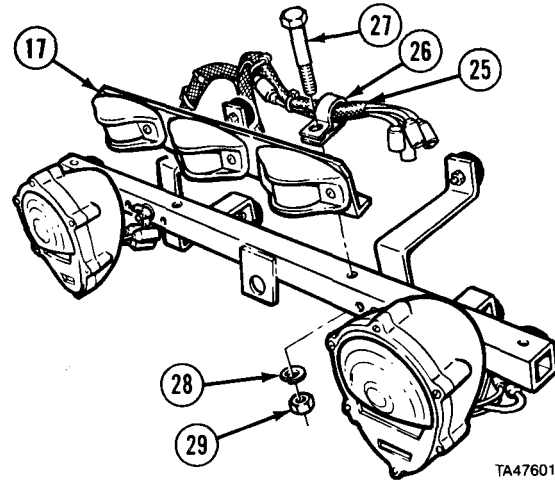


- (7) Install eight pins (22) on wires (23).
- (8) Install eight wires (23) in connector (24).

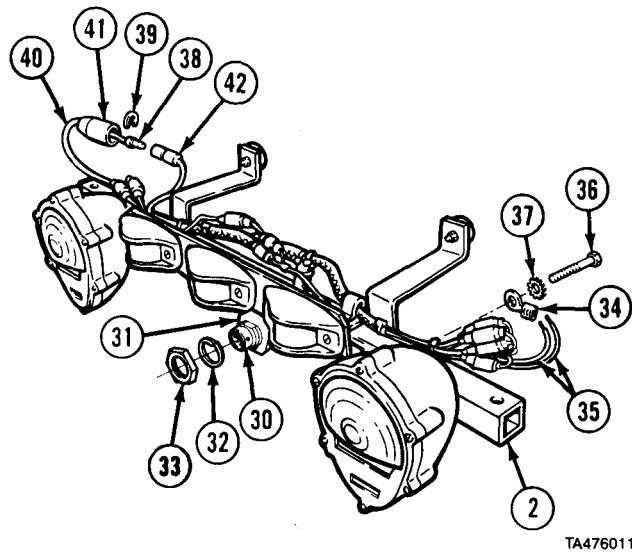


Electrical System Maintenance Instructions (Cont)

- (9) Install clearance light bracket (17), wiring harness (25), and clips (26) with two screws (27), lockwashers (28), and nuts (29).



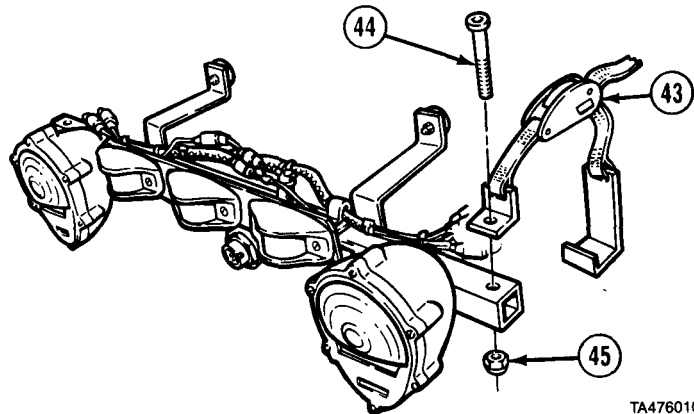
- (10) Install connector (30) in tow light tab (31) with lockwasher (32) and nut (33).
- (11) Install connector (34) on two ground wires (35).
- (12) Install connector (34) with screw (36) and lockwasher (37).
- (13) Install 11 pins (38) and washers (39) on wires (40).
- (14) Connect 11 connectors (41) to connectors (42).



- (15) Install four emergency straps (43) with two screws (44) and locknuts (45).

c. Follow-on Maintenance.

- (1) Check operation of emergency tow lights (TM 9-2320-279-10).
- (2) Return emergency tow lights to stowage (TM 9-2320-279-10).



END OF TASK

Electrical System Maintenance Instructions (Cont)

| | |
|--|--|
| 7-74. RED AND AMBER MARKER LIGHTS REMOVAL/INSTALLATION (M978). | |
| This task covers: | |
| a. Removal | c. Follow-on Maintenance |
| b. Installation | |
| INITIAL SETUP | |
| <i>Models</i> | <i>References</i> |
| M978 | None |
| <i>Test Equipment</i> | <i>Equipment Condition</i> |
| None | <i>TM or Para</i> <i>Condition Description</i> |
| <i>Special Tools</i> | Para 7-91 Batteries disconnected. |
| None | <i>Special Environmental Conditions</i> |
| <i>Supplies</i> | None |
| Connector, electrical, butt, Item 19, Appendix C | <i>General Safety Instructions</i> |
| <i>Personnel Required</i> | No smoking, flame, sparks, and hot or glowing objects within 50 ft (15 m) of vehicle. |
| MOS 63S, Heavy wheel vehicle mechanic | |

a. Removal.

NOTE

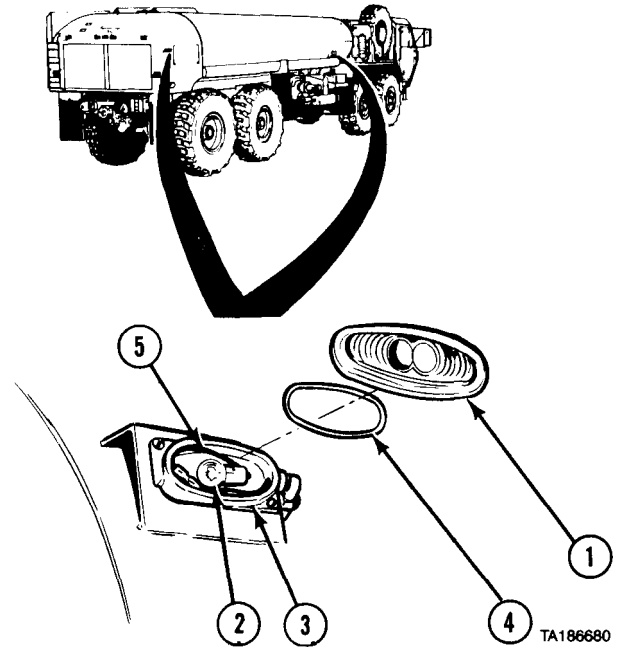
Red and amber marker lights are removed the same way.

- (1) Remove lens (1) and lamp (2) from marker light (3).

NOTE

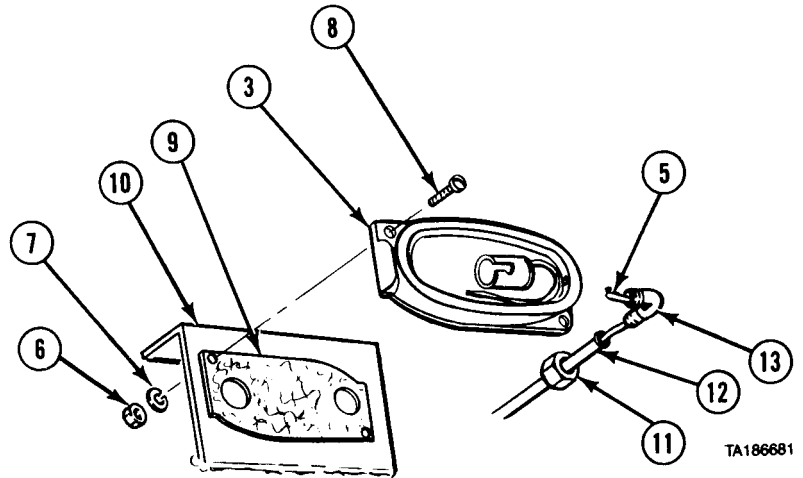
Do steps (2) through (5) only when entire marker light assembly is to be removed.

- (2) Remove preformed packing (4) and cut wire (5).



Electrical System Maintenance Instructions (Cont)

- (3) Remove two nuts (6), lockwashers (7), screws (8), marker light (3), and gasket (9) from mount (10).
- (4) Remove nut (11), tubing (12), and wire (5) from elbow (13).
- (5) Remove elbow (13) from marker light (3).

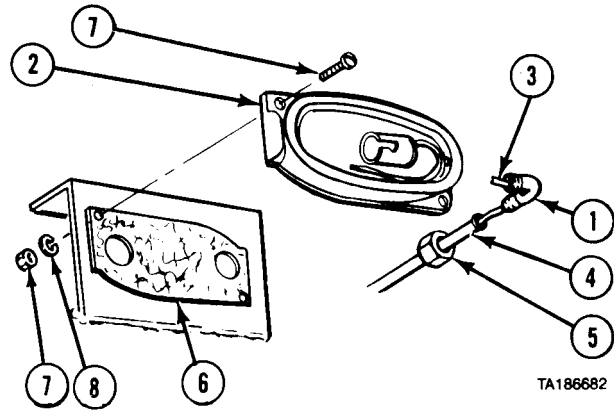


b. Installation.

NOTE

- Red and amber marker lights are installed the same way.
- Do steps (1) through (6) only if entire marker light assembly has been removed. Otherwise, do steps (6) and (7) only.

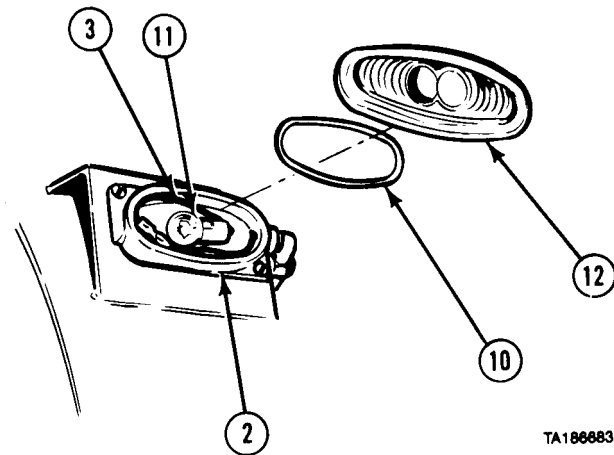
- (1) Install elbow (1) on marker light (2).
- (2) Push wire (3) through elbow (1) and install tubing (4) and nut (5) on elbow.
- (3) Install gasket (6) and marker light (2) with two screws (7), lockwashers (8), and nuts (9).



- (4) Connect wire (3) using electrical butt connector.
- (5) Install preformed packing (10).
- (6) Install lamp (11) in marker light (2).
- (7) Install lens (12).

c. Follow-on Maintenance.

- (1) Connect batteries (para 7-91).
- (2) Check operation of marker lights (TM 9-2320-279-10).



END OF TASK

Electrical System Maintenance Instructions (Cont)

| | |
|---|--|
| 7-75. PUMP MODULE CLEARANCE LIGHTS REMOVAL/INSTALLATION (M978). | |
| This task covers: | |
| a. Removal | c. Follow-on Maintenance |
| b. Installation | |
| INITIAL SETUP | |
| <i>Models</i> | <i>References</i> |
| M978 | None |
| <i>Test Equipment</i> | <i>Equipment Condition</i> |
| None | <i>TM or Para</i> <i>Condition Description</i> |
| <i>Special Tools</i> | TM 9-2320-279-10 Pump module rear access doors open. |
| None | Para 7-91 Batteries disconnected. |
| <i>Supplies</i> | <i>Special Environmental Conditions</i> |
| Connector, electrical, butt, Item 19, Appendix C | None |
| <i>Personnel Required</i> | <i>General Safety Instructions</i> |
| MOS 63S, Heavy wheel vehicle mechanic | None |

a. Removal.

NOTE

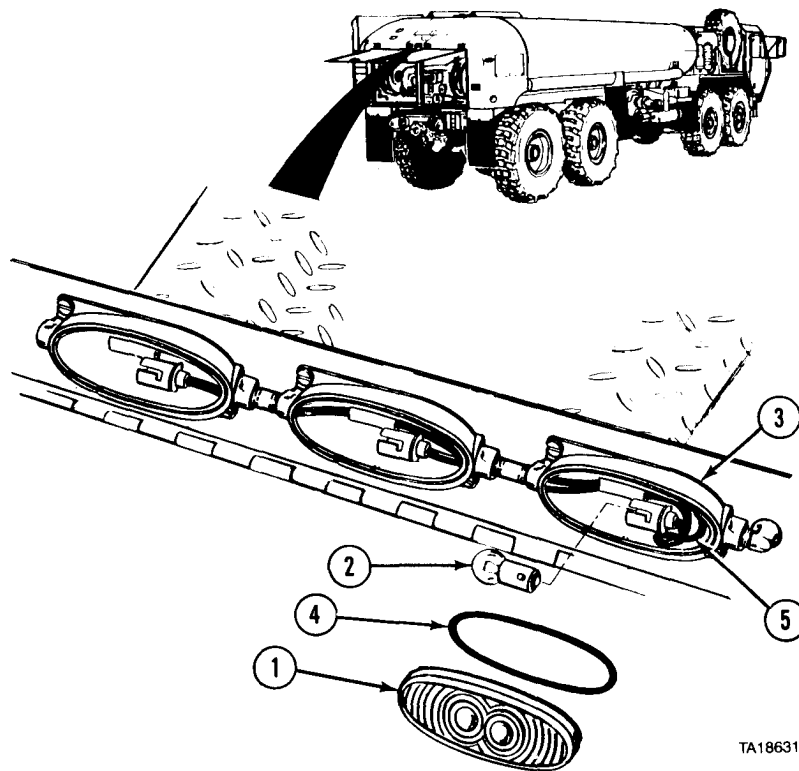
All clearance lights are removed the same way.

- (1) Remove three lenses (1) and lamps (2) from clearance lights (3).

NOTE

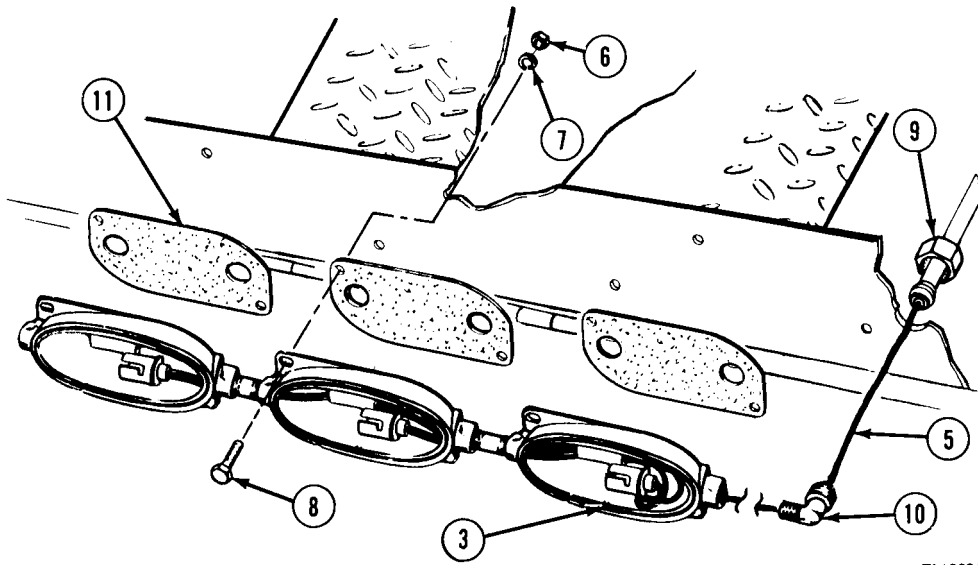
Do steps (2) through (7) only when entire clearance light assembly is to be removed.

- (2) Remove three preformed packings (4) and cut wire (5).



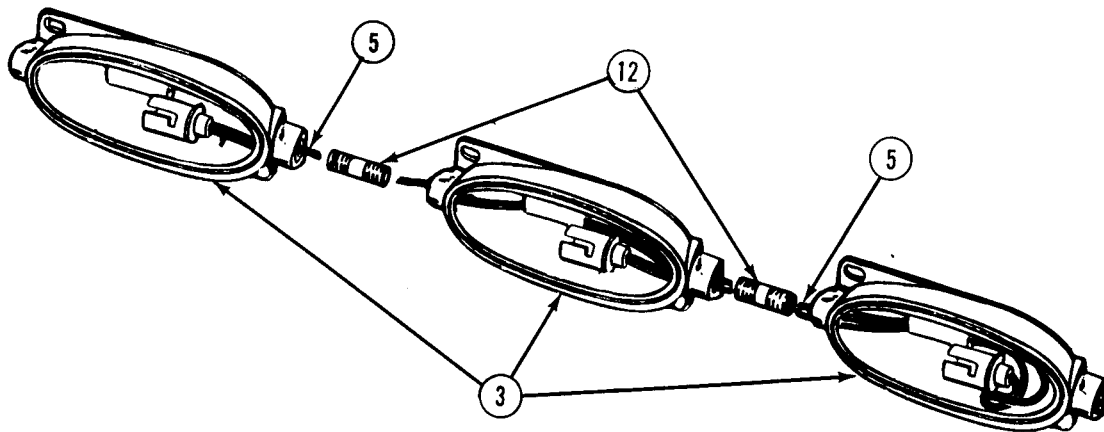
TA186314

Electrical System Maintenance Instructions (Cont)



TA186315

- (3) Remove six nuts (6), lockwashers (7), and screws (8).
- (4) Remove nut (9) from elbow (10). Remove three clearance lights (3) and gaskets (11) from pump module.
- (5) Pull wire (5) through elbow (10).
- (6) Remove elbow (10) from clearance lights (3).



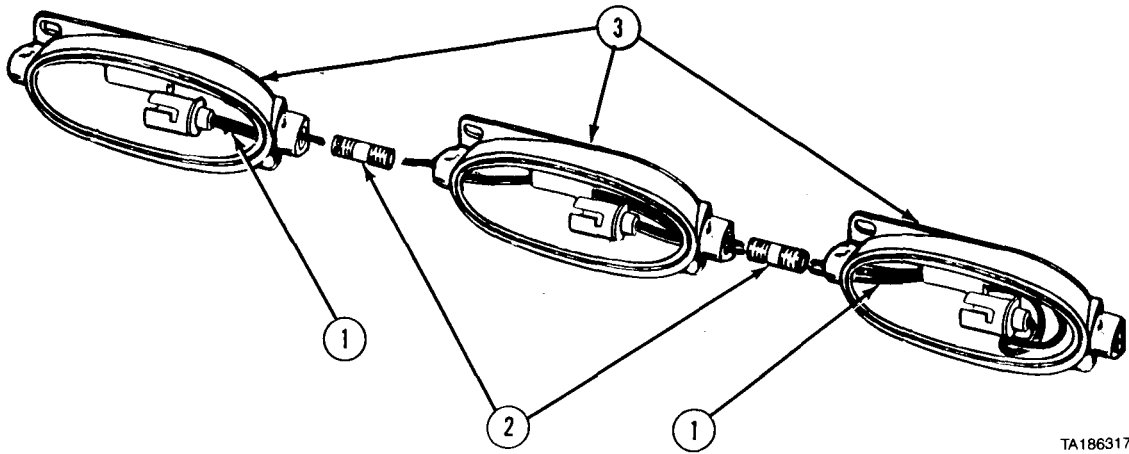
TA186316

- (7) Cut wires (5) and remove three clearance lights (3) from two nipples (12).

Electrical System Maintenance Instructions (Cont)

7-75. PUMP MODULE CLEARANCE LIGHTS REMOVAL/INSTALLATION (M978) (CONT).

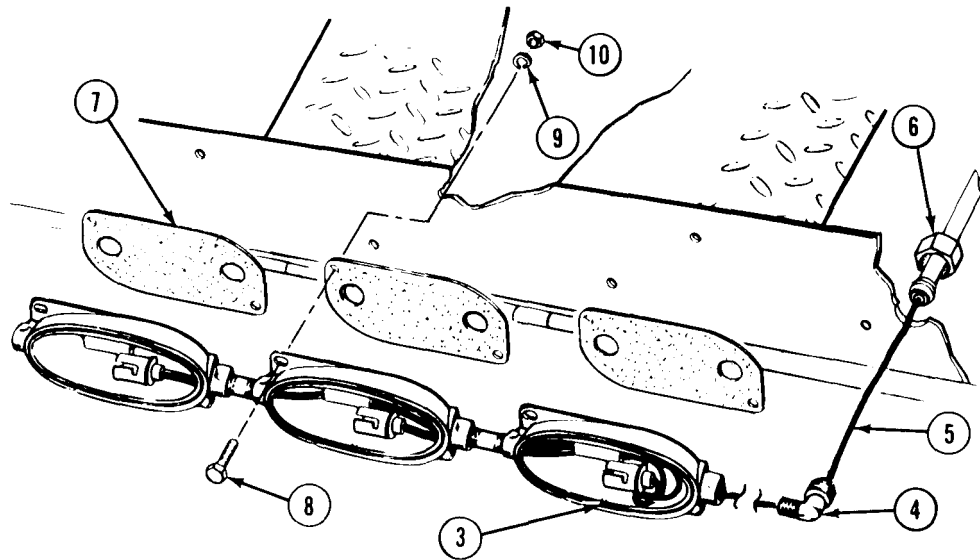
b. Installation.



NOTE

Do steps (1) through (10) only if entire clearance light assembly has been removed. Otherwise, do steps (9) and (10) only.

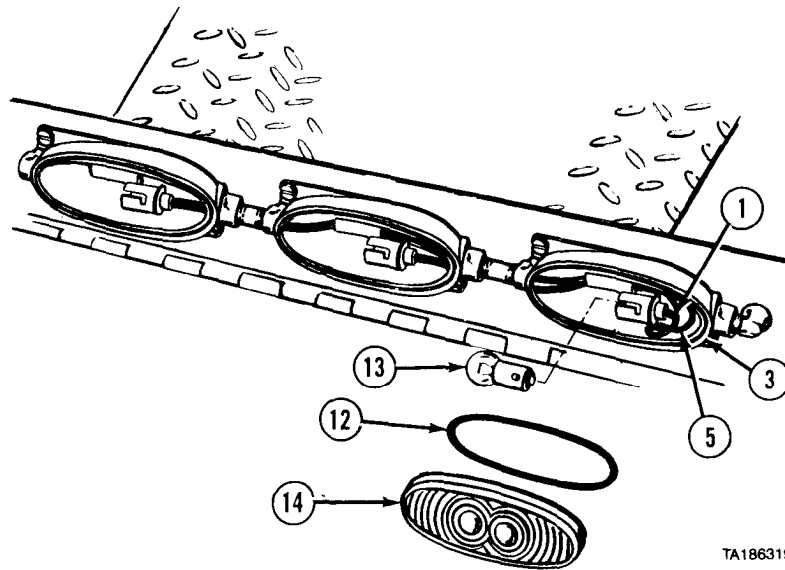
- (1) Feed wires (1) through two nipples (2) and install three clearance lights (3) on nipples (2).
- (2) Connect wires (1) using butt connectors.



- (3) Install elbow (4) on clearance light (3).
- (4) Push wire (5) through elbow (4).
- (5) Install nut (6) on elbow (4).
- (6) Install three gaskets (7) and clearance lights (3) on pump module with six screws (8), lockwashers (9), and nuts (10).

Electrical System Maintenance Instructions (Cont)

- (7) Connect wires (1 and 5) using butt connector.
- (8) Install three preformed packings (12).
- (9) Install three lamps (13) in clearance lights (3).
- (10) Install three lenses (14).
- c. *Follow-on Maintenance.*
 - (1) Connect batteries (para 7-91).
 - (2) Check operation of clearance lights (TM 9-2320-279-10).
 - (3) Close pump module rear access doors (TM 9-2320-279-10).



TA186319

END OF TASK

| | |
|---|---|
| 7-76. PUMP MODULE COMPARTMENT LIGHTS REMOVAL/INSTALLATION (M978). | |
| This task covers: | |
| <ul style="list-style-type: none"> a. Removal b. Installation | <ul style="list-style-type: none"> c. Follow-on Maintenance |
| INITIAL SETUP | |
| <i>Models</i> | <i>References</i> |
| M978 | None |
| <i>Test Equipment</i> | <i>Equipment Condition</i> |
| None | |
| <i>Special Tools</i> | <i>TM or Para</i> |
| None | |
| <i>Supplies</i> | <i>Condition Description</i> |
| Connectors, electrical, butt, Item 19, Appendix C | TM 9-2320-279-10 Pump module rear access doors opened. |
| Tags, identification, Item 48, Appendix C | Para 7-91 Batteries disconnected. |
| <i>Personnel Required</i> | <i>Special Environmental Conditions</i> |
| MOS 63S, Heavy wheel vehicle mechanic | None |
| | <i>General Safety Instructions</i> |
| | No smoking, flame, sparks, and hot or glowing objects within 50 ft (15 m) of vehicle. |

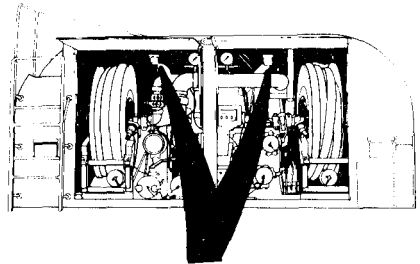
Electrical System Maintenance Instructions (Cont)

7-76. PUMP MODULE COMPARTMENT LIGHTS REMOVAL/INSTALLATION (M978) (CONT).

a. Removal.

NOTE

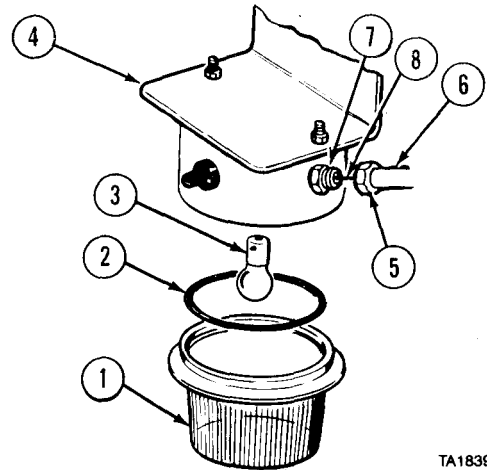
- Left and right compartment lights are removed the same way.
 - Tag and mark wires before removal.
- (1) Remove compartment light lens (1), preformed packing (2), and lamp (3) from base (4).



NOTE

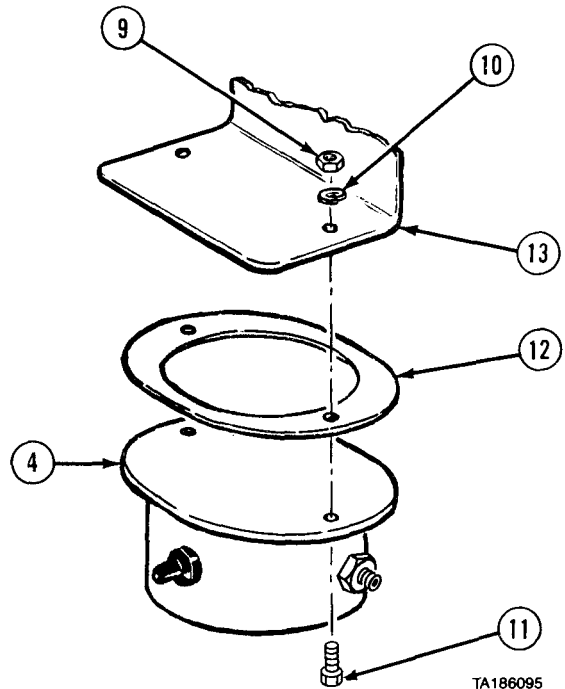
Do steps (2) through (9) only when entire light assembly is to be removed.

- (2) Remove three nuts (5) and conduit tubes (6) from adapters (7).
- (3) Cut five wires (8).



TA183961

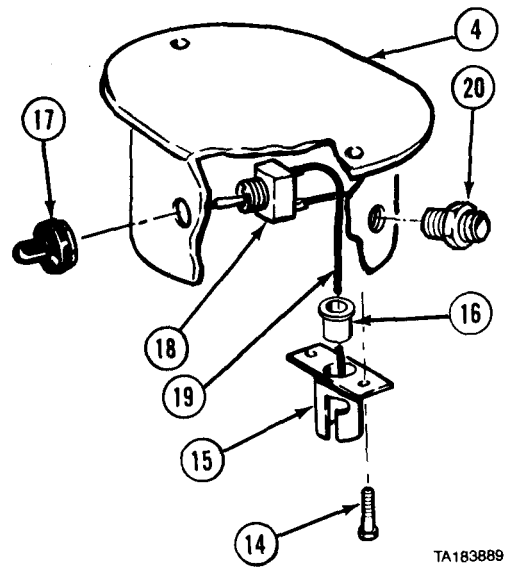
- (4) Remove two nuts (9), lockwashers (10), and screws (11) from base (4).
- (5) Remove base (4) and gasket (12) from bracket (13).



TA186095

Electrical System Maintenance Instructions (Cont)

- (6) Remove two screws (14), one socket (15), and grommet (16).
- (7) Remove boot (17) and switch (18) from base (4).
- (8) Cut wire (19) between switch (18) and socket (15).
- (9) Remove three adapters (20).

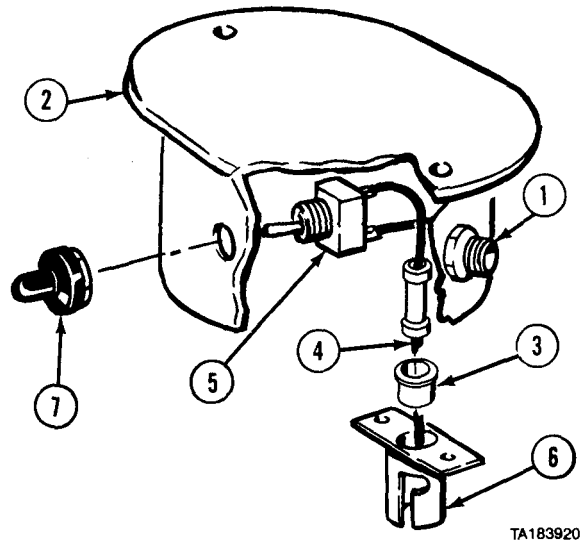


b. Installation.

NOTE

Do steps (1) through (9) only when entire light assembly has been removed. Otherwise, do step (9) only.

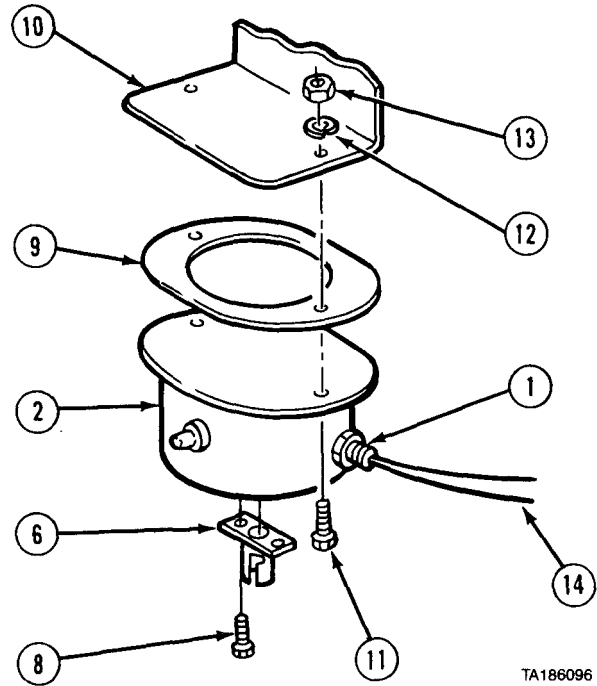
- (1) Install three adapters (1) in base (2).
- (2) Install grommet (3) on wire (4).
- (3) Connect wire (4) between switch (5) and socket (6) using butt connector.
- (4) Install switch (5) in base (2) with boot (7).



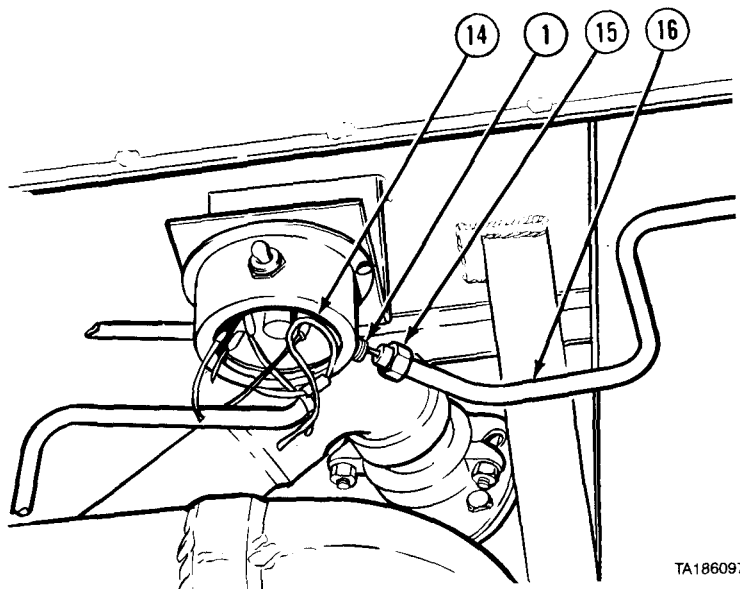
Electrical System Maintenance Instructions (Cont)

7-76. PUMP MODULE COMPARTMENT LIGHTS REMOVAL/INSTALLATION (M978) (CONT).

- (5) Install socket (6) in base (2) with two screws (8).
- (6) Install gasket (9) and base (2) on bracket (10) with two screws (11), lockwashers (12), and nuts (13).
- (7) Thread five wires (14) through adapters (1) into base (2).



- (8) Connect five wires (14) using butt connectors and install three nuts (15) and conduit tubes (16) on adapters (1).



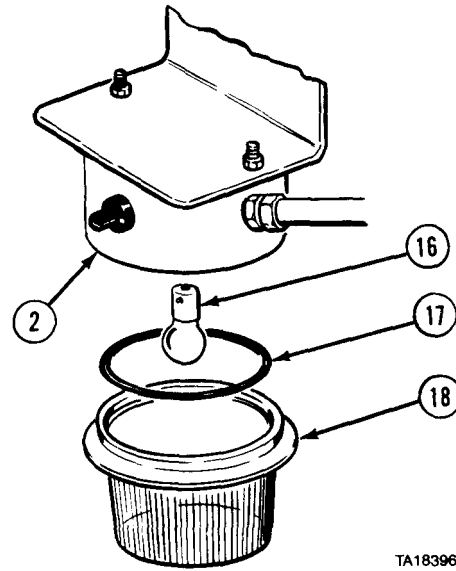
Electrical System Maintenance Instructions (Cont)

(9) Install lamp (17), preformed packing (18), and compartment light lens (19) in base (2).

c. Follow-on Maintenance.

- (1) Connect batteries (para 7-91).
- (2) Check operation of compartment lights (TM 9-2320-279-10).
- (3) Close pump module rear access doors (TM 9-2320-279-10).

END OF TASK



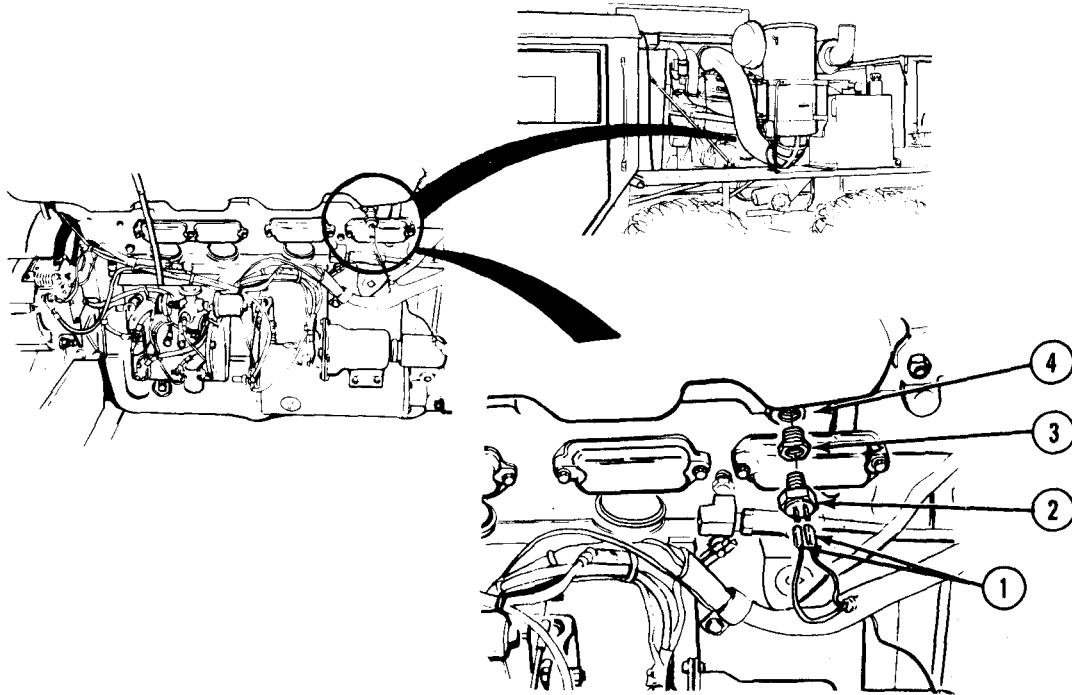
Section IX. SENDING UNITS AND WARNING SYSTEMS

| | |
|---|--|
| 7-77. ETHER STARTING AID THERMOSTAT REMOVAL/INSTALLATION. | |
| This task covers: | |
| a. Removal | c. Follow-on Maintenance |
| b. Installation | |
| INITIAL SETUP | |
| <i>Models</i> | <i>References</i> |
| All | None |
| <i>Test Equipment</i> | <i>Equipment Condition</i> |
| None | <i>TM or Para</i> <i>Condition Description</i> |
| <i>Special Tools</i> | TM 9-2320-279-10 Engine side panel removed. |
| None | Para 6-2 Cooling system drained. |
| <i>Supplies</i> | <i>Special Environmental Conditions</i> |
| Compound, sealing, pipe thread, Item 18, Appendix C | None |
| Tags, identification, Item 48, Appendix C | <i>General Safety Instructions</i> |
| <i>Personnel Required</i> | None |
| MOS 63S, Heavy wheel vehicle mechanic | |

Electrical System Maintenance Instructions (Cont)

7-77. ETHER STARTING AID THERMOSTAT REMOVAL/INSTALLATION (CONT).

a. Removal.



TA185451

NOTE

Tag and mark wires before disconnecting or removing.

- (1) Disconnect two wires (1) from thermostat (2).
- (2) Remove thermostat (2) from reducer bushing (3).
- (3) Remove reducer bushing (3) from engine (4).

b. Installation.

WARNING

Adhesives, solvents, and sealing compounds can burn easily, can give off harmful vapors, and are harmful to skin and clothing. To avoid injury or death, keep away from open fire and use in well-ventilated area. If adhesive, solvent, or sealing compound gets on skin or clothing, wash immediately with soap and water.

- (1) Coat threads of reducer bushing (3) and thermostat (2) with pipe thread sealing compound.
- (2) Install reducer bushing (3) in engine (4).
- (3) Install thermostat (2) in reducer bushing (3).
- (4) Connect two wires (1) to thermostat (2).

c. Follow-on Maintenance.

- (1) Fill cooling system (para 6-2).
- (2) Install engine side panel (TM 9-2320-279-10).

END OF TASK

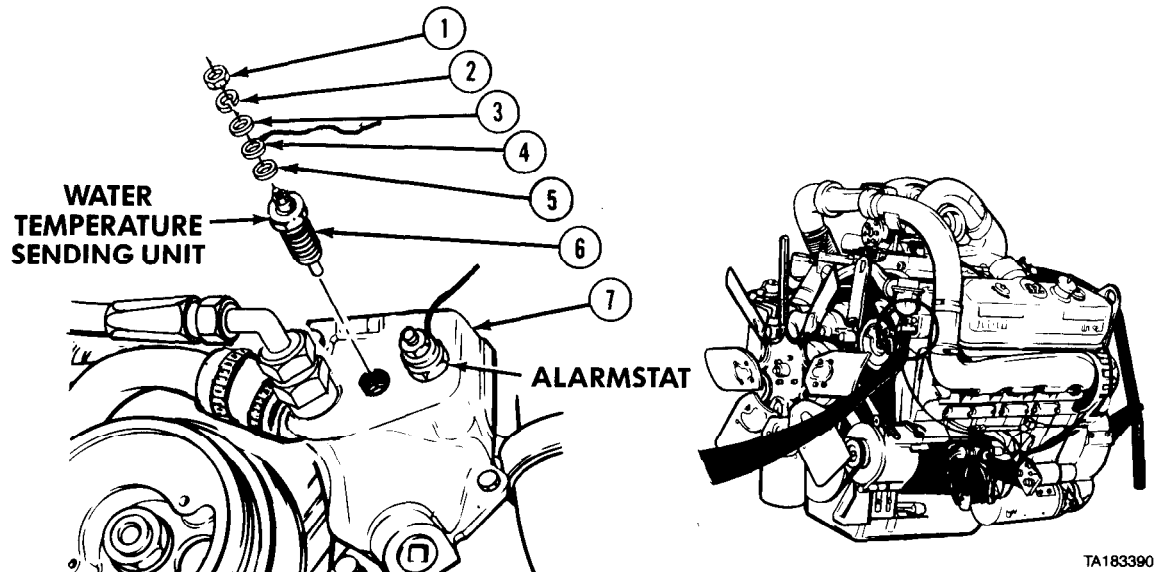
Electrical System Maintenance Instructions (Cont)

| | |
|---|---|
| 7-78. WATER TEMPERATURE SENDING UNIT AND ALARMSTAT REMOVAL/INSTALLATION. | |
| This task covers: | |
| a. Removal b. Installation | c. Follow-on Maintenance |
| INITIAL SETUP | |
| <i>Models</i> All | <i>References</i> None |
| <i>Test Equipment</i> None | <i>Equipment Condition</i> |
| <i>Special Tools</i> None | <i>TM or Para</i> <i>Condition Description</i> |
| <i>Supplies</i> Compound, sealing, pipe thread, Item 18, Appendix C | TM 9-2320-279-10 Engine cover open. TM 9-2320-279-10 Engine side panel removed. Para 7-91 Batteries disconnected. Para 6-2 Cooling system drained. |
| <i>Personnel Required</i> MOS 63S, Heavy wheel vehicle mechanic | <i>Special Environmental Conditions</i> None |
| | <i>General Safety Instructions</i> None |

Electrical System Maintenance Instructions (Cont)

7-78. WATER TEMPERATURE SENDING UNIT AND ALARMSTAT REMOVAL/INSTALLATION (CONT).

a. Removal.



NOTE

- Water temperature sending unit and alarmstat are removed and installed in same way.
- Water temperature sending unit shown.

- (1) Remove nut (1), lockwasher (2), washer (3), wire (4), and insulator (5) from sending unit (6).
- (2) Remove sending unit (6) from thermostat housing (7).

b. Installation.

WARNING

Adhesives, solvents, and sealing compounds can burn easily, can give off harmful vapors, and are harmful to skin and clothing. To avoid injury or death, keep away from open fire and use in well-ventilated area. If adhesive, solvent, or sealing compound gets on skin or clothing, wash immediately with soap and water.

- (1) Coat threads of sending unit (6) with pipe thread sealing compound, leaving last two threads bare.
- (2) Install sending unit (6) in thermostat housing (7).
- (3) Install insulator (5), wire (4), washer (3), lockwasher (2), and nut (1) on sending unit (6) and tighten to not more than 20 lb-in. (2.26 N-m).

c. Follow-on Maintenance.

- (1) Fill cooling system (para 6-2).
- (2) Connect batteries (para 7-91).
- (3) Start and warm up engine, check operation of water temperature sending unit and alarmstat, and check for leaks (TM 9-2320-279-10).
- (4) Shut off engine (TM 9-2320-279-10).
- (5) Install engine side panel (TM 9-2320-279-10).
- (6) Close engine cover (TM 9-2320-279-10).

END OF TASK

Electrical System Maintenance Instructions (Cont)

| | |
|--|--|
| 7-79. OIL PRESSURE SENDING UNIT REMOVAL/INSTALLATION. | |
| This task covers: | |
| a. Removal | c. Follow-on Maintenance |
| b. Installation | |
| INITIAL SETUP | |
| <i>Models</i> | <i>References</i> |
| All | None |
| <i>Test Equipment</i> | <i>Equipment Condition</i> |
| None | <i>TM or Para</i> <i>Condition Description</i> |
| <i>Special Tools</i> | TM 9-2320-279-10 Engine cover open. |
| None | TM 9-2320-279-10 Engine side panel removed. |
| <i>Supplies</i> | Para 7-91 Batteries disconnected. |
| Compound, sealing, pipe thread, Item 18, Appendix C | <i>Special Environmental Conditions</i> |
| Sealant, RTV200 Electrical, Item 45.05, Appendix C | None |
| Tags, identification, Item 48, Appendix C | <i>General Safety Instructions</i> |
| <i>Personnel Required</i> | None |
| MOS 63S, Heavy wheel vehicle mechanic | |

Electrical System Maintenance Instructions (Cont)

a. Removal.

NOTE

Tag and mark wires before removing.

- (1) Remove nut (1), lockwasher (2), washer (3), and wire (4) from oil pressure sending unit (5).
- (2) Remove oil pressure sending unit (5) from manifold (6).

b. Installation.

WARNING

Adhesives, solvents, and sealing compounds can burn easily, can give off harmful vapors, and are harmful to skin and clothing. To avoid injury or death, keep away from open fire and use in well-ventilated area. If adhesive, solvent, or sealing compound gets on skin or clothing, wash immediately with soap and water.

- (1) Coat threads of oil pressure sending unit (5) with pipe thread sealing compound, install on manifold (6), and tighten.

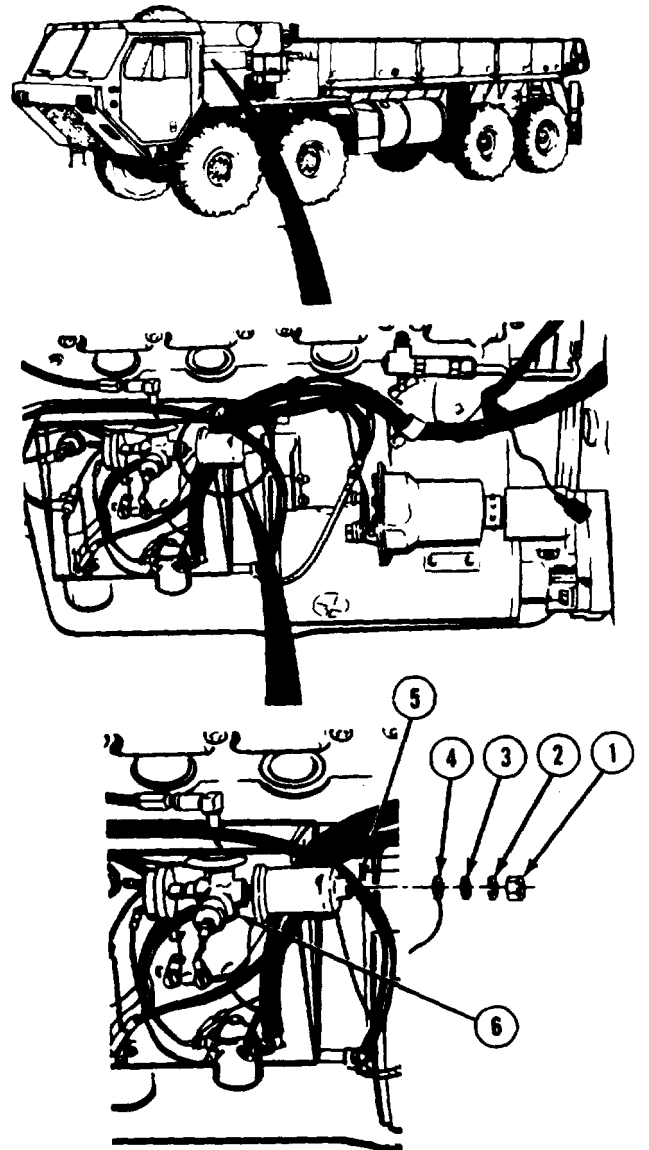
NOTE

Apply electrical sealant to exposed wire connectors after installing connectors.

- (2) Install wire (4), washer (3), and lockwasher (2) on oil pressure sending unit (5).
- (3) Install nut (1) and tighten.

c. Follow-on Maintenance.

- (1) Connect batteries (para 7-91).
- (2) Start engine, check operation of oil pressure sending unit, and check for leaks (TM 9-2320-279-10).
- (3) Shut off engine (TM 9-2320-279-10).
- (4) Install engine side panel (TM 9-2320-279-10).
- (5) Close engine cover (TM 9-2320-279-10).



END OF TASK

Electrical System Maintenance Instructions (Cont)

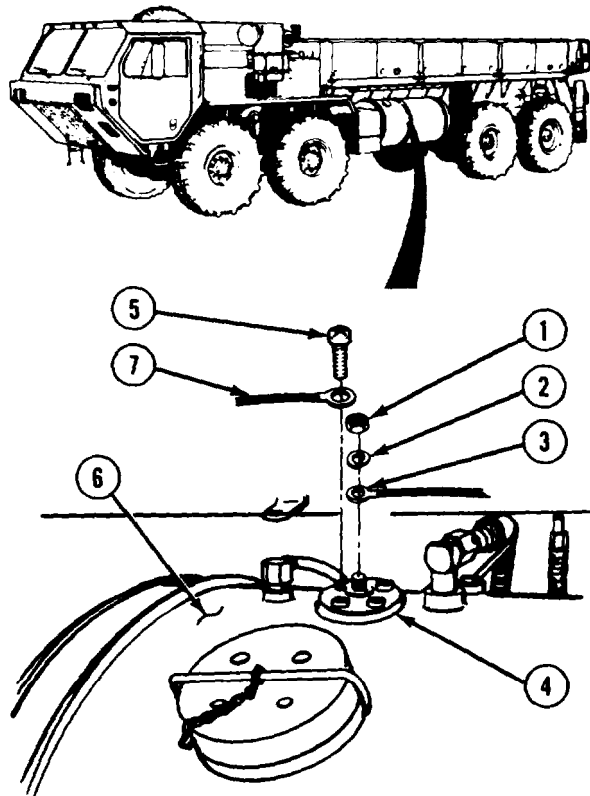
| | |
|--|---|
| 7-80. FUEL LEVEL SENDING UNIT REMOVAL/INSTALLATION. | |
| This task covers: | |
| a. Removal | c. Follow-on Maintenance |
| b. Installation | |
| INITIAL SETUP | |
| Models All | References None |
| Test Equipment None | Equipment Condition TM or Para Condition Description Para 7-91 Batteries disconnected. |
| Special Tools None | Special Environmental Conditions None |
| Supplies Tags, identification, Item 48, Appendix C Compound, sealing, pipe thread, Item 18, Appendix C | General Safety Instructions No smoking, open flame, or sparks within 50 ft (15 m) of vehicle. Fire extinguisher nearby. |
| Personnel Required MOS 63S, Heavy wheel vehicle mechanic | |

a. Removal.

NOTE

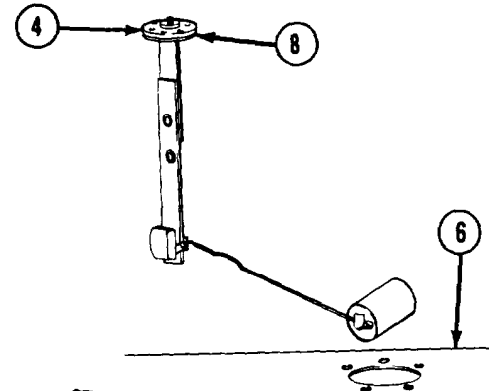
Tag and mark wires before removing.

- (1) Remove nut (1), lockwasher (2), and disconnect wire (3) from fuel level sending unit (4).
- (2) Remove five screws (5) holding fuel level sending unit (4) to fuel tank (6). Remove ground wire (7).



Electrical System Maintenance Instructions (Cont)

- (3) Lift fuel level sending unit (4) with gasket (8) out of fuel tank (6).

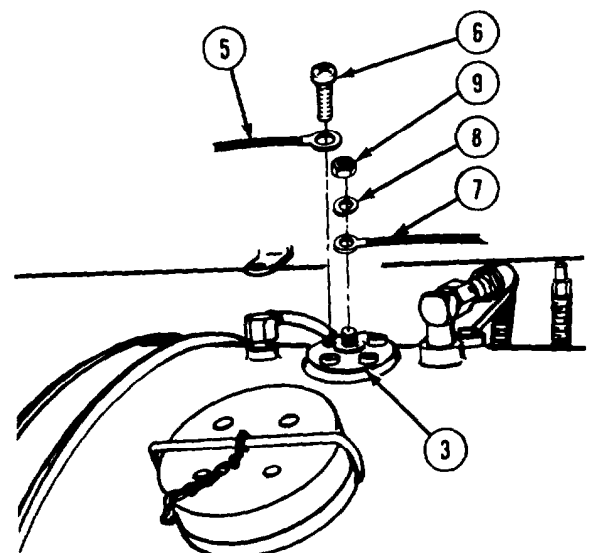
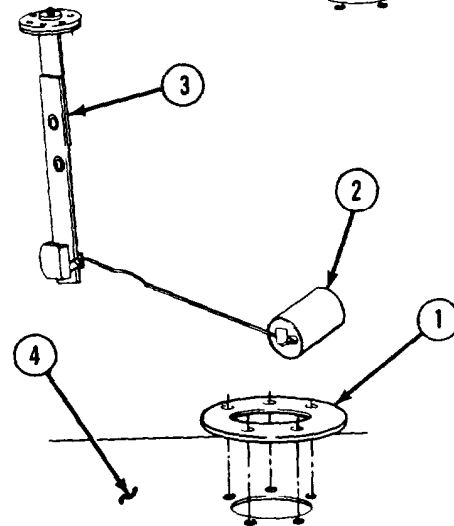


b. Installation.

WARNING

Adhesives, solvents, and sealing compounds can burn easily, can give off harmful vapors, and are harmful to skin and clothing. To avoid injury or death, keep away from open fire and use in well-ventilated area. If adhesive, solvent, or sealing compound gets on skin or clothing, wash immediately with soap and water.

- (1) Coat both sides of gasket (1) with sealing compound, slide gasket (1) over float (2) and install on fuel level sending unit (3).
- (2) Install fuel level sending unit (3) in fuel tank (4) and align holes in fuel sending unit with holes in fuel tank.
- (3) Install ground wire (5) on one of five screws (6) and install five screws on fuel level sending unit (3). Tighten five screws.
- (4) Install wire (7) with lockwasher (8) and nut (9) on fuel level sending unit (3)



c. Follow-on Maintenance.

- (1) Connect batteries (para 7-91).
- (2) Check operation of fuel sending unit (TM 9-2320-279-10).

END OF TASK

Electrical System Maintenance Instructions (Cont)

7-81. SPEEDOMETER SENDING UNIT REMOVAL/INSTALLATION.

This task covers:

- a. Removal
- b. Installation
- C. Follow-on Maintenance

INITIAL SETUP

Models

All

Test Equipment

None

Special Tools

None

Supplies

Tape, insulation, electrical, Item 50, Appendix C
Ties, cable, plastic, Item 52, Appendix C

Personnel Required

MOS 63S. Heavy wheel vehicle mechanic

References

None

Equipment Condition

| | | |
|------------|-----------|---------------|
| TM or Para | Condition | Description |
| Para 7-91 | Batteries | disconnected. |

Special Environmental Conditions

None

General Safety Instructions

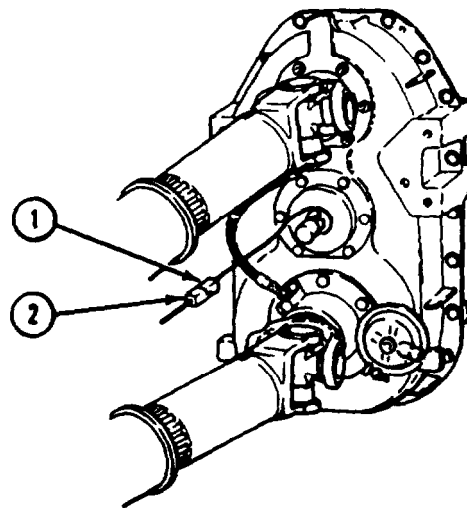
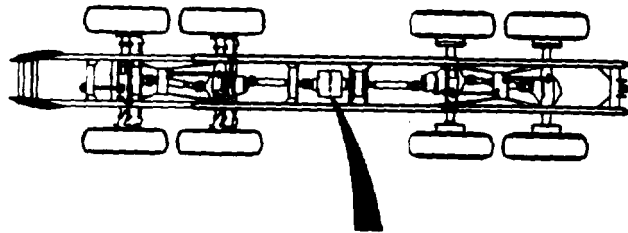
None

a. Removal.

NOTE

Cut plastic cable ties as necessary to free wires from speedometer sending unit.

- (1) Remove tape and pull sending unit end connector (1) from speedometer end connector (2).



TA186806

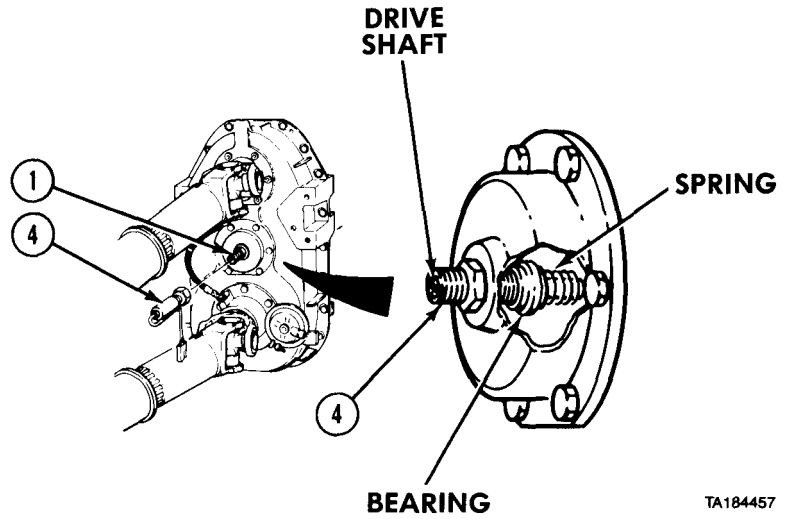
Electrical System Maintenance Instructions (Cont)

7-81. SPEEDOMETER SENDING UNIT REMOVAL/INSTALLATION (CONT).

CAUTION

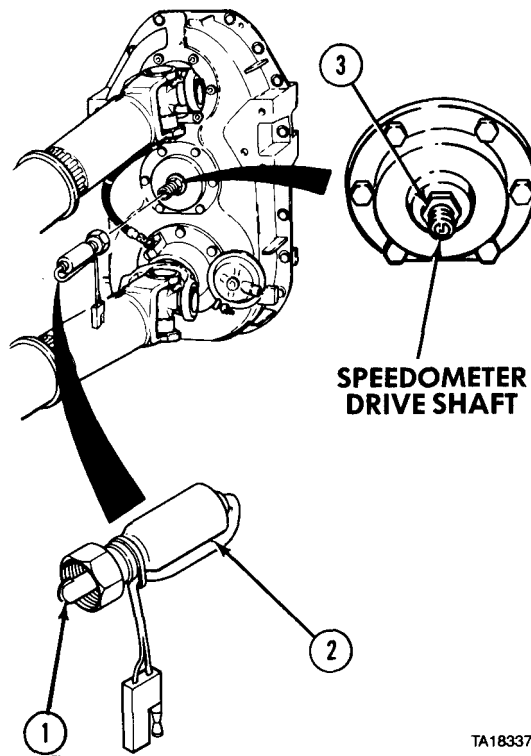
Do not pull drive shaft more than 0.50-in. (13 mm) out of sleeve. Spring and bearing behind sleeve can fall into end cap and cause damage to equipment. If spring and bearing fall into end cap, notify the supervisor.

- (2) Remove speedometer sending unit (3) from reducer tube (4).



TA184457

b. Installation.



TA183370

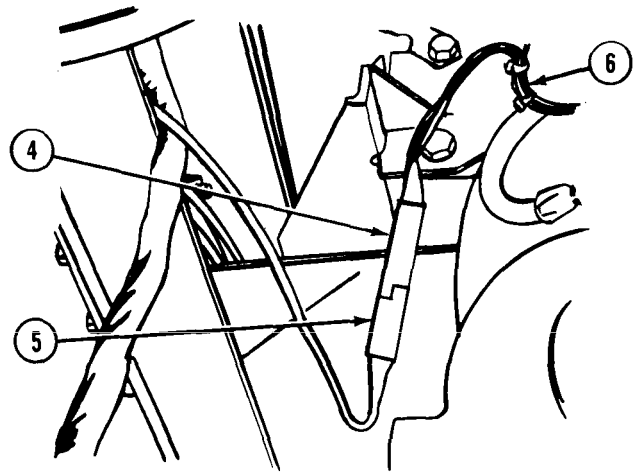
- (1) Line up drive tang (1) of speedometer sending unit (2) with slot on drive shaft in reducer tube (3).
- (2) Install speedometer sending unit (2) on reducer tube (3) and tighten.

Electrical System Maintenance Instructions (Cont)

- (3) Connect sending unit end connector (4) to speedometer end connector (5). Wrap electrical insulation tape around connectors.
- (4) Use plastic cable ties to bundle cable (6).

c. Follow-on Maintenance.

- (1) Connect batteries (para 7-91).
- (2) Check operation of speedometer (TM 9-2320-279-10).



END OF TASK

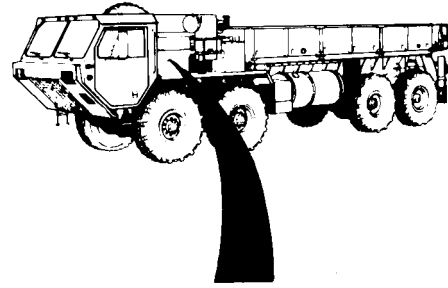
| 7-82. HOUR METER OIL PRESSURE SWITCH REMOVAL/INSTALLATION. | |
|---|--|
| This task covers: | |
| a. Removal | c. Follow-on Maintenance |
| b. Installation | |
| INITIAL SETUP | |
| <i>Models</i> | <i>References</i> |
| All | None |
| <i>Test Equipment</i> | <i>Equipment Condition</i> |
| None | <i>TM or Para</i> <i>Condition Description</i> |
| <i>Special Tools</i> | TM 9-2320-279-10 Engine cover open. |
| None | TM 9-2320-279-10 Engine side panel removed. |
| <i>Supplies</i> | Para 7-91 Batteries disconnected. |
| Compound, sealing, pipe thread, Item 18, Appendix C | <i>Special Environmental Conditions</i> |
| Sealant, RTV200 Electrical, Item 45.05, Appendix C | None |
| Tags, identification, Item 48, Appendix C | <i>General Safety Instructions</i> |
| <i>Personnel Required</i> | None |
| MOS 63S, Heavy wheel vehicle mechanic | |

Electrical System Maintenance Instructions (Cont)

a. Removal.**NOTE**

Tag and mark wires before removing.

- (1) Remove two screws (1) and wires (2) from oil pressure switch (3).
- (2) Remove oil pressure switch (3) from manifold (4).

**b. Installation.****WARNING**

Adhesives, solvents, and sealing compounds can burn easily, can give off harmful vapors, and are harmful to skin and clothing. To avoid injury or death, keep away from open fire and use in well-ventilated area. If adhesive, solvent, or sealing compound gets on skin or clothing, wash immediately with soap and water.

- (1) Coat threads of oil pressure switch (3) with pipe thread sealing compound, and install oil pressure switch in manifold (4).

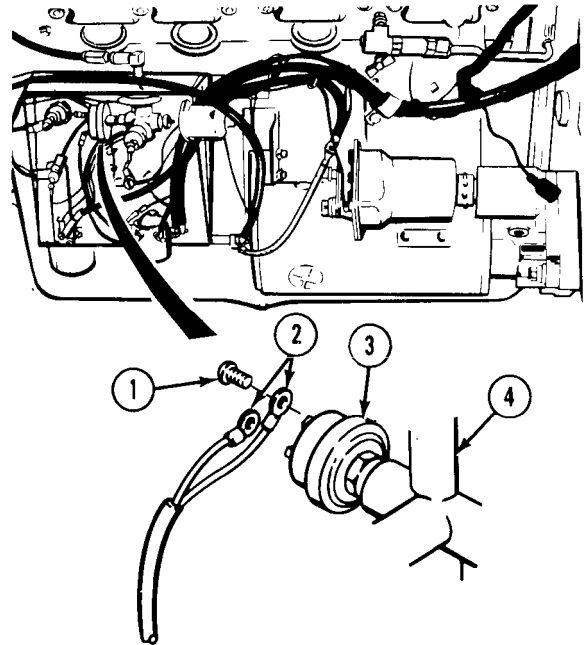
NOTE

Apply electrical sealant to exposed wire connectors after installing connectors.

- (2) Connect two wires (2) to oil pressure switch (3) with two screws (1).

c. Follow-on Maintenance.

- (1) Connect batteries (para 7-91).
- (2) Check operation of hour meter (TM 9-2320-279-10).
- (3) Install engine side panel (TM 9-2320-279-10).
- (4) Close engine cover (TM 9-2320-279-10).

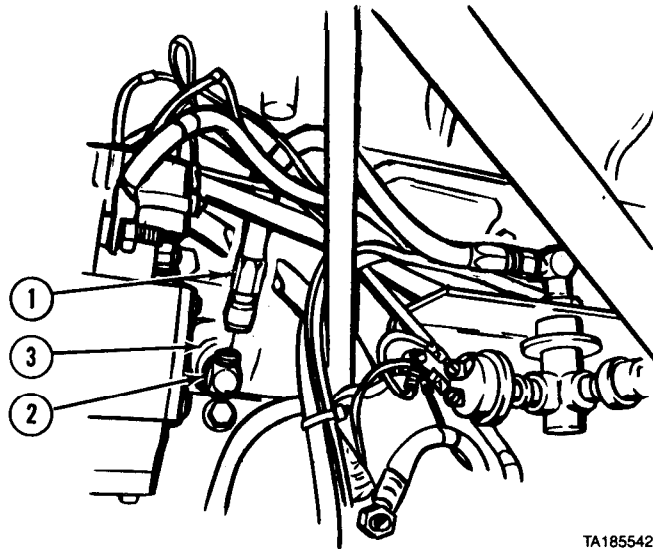
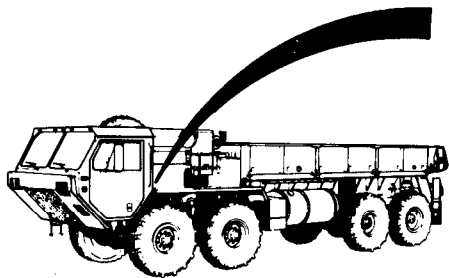


END OF TASK

Electrical System Maintenance Instructions (Cont)

| | |
|---|--|
| 7-83. OIL MANIFOLD HOSE REMOVAL/INSTALLATION. | |
| This task covers: | |
| a. Removal | c. Follow-on Maintenance |
| b. Installation | |
| INITIAL SETUP | |
| <i>Models</i> | <i>References</i> |
| All | None |
| <i>Test Equipment</i> | <i>Equipment Condition</i> |
| None | <i>TM or Para</i> <i>Condition Description</i> |
| <i>Special Tools</i> | TM 9-2320-279-10 Engine side panel removed. |
| None | <i>Special Environmental Conditions</i> |
| <i>Supplies</i> | None |
| Compound, sealing, pipe thread, Item 18, Appendix C | <i>General Safety Instructions</i> |
| <i>Personnel Required</i> | None |
| MOS 63S, Heavy wheel vehicle mechanic | |

a. Removal.



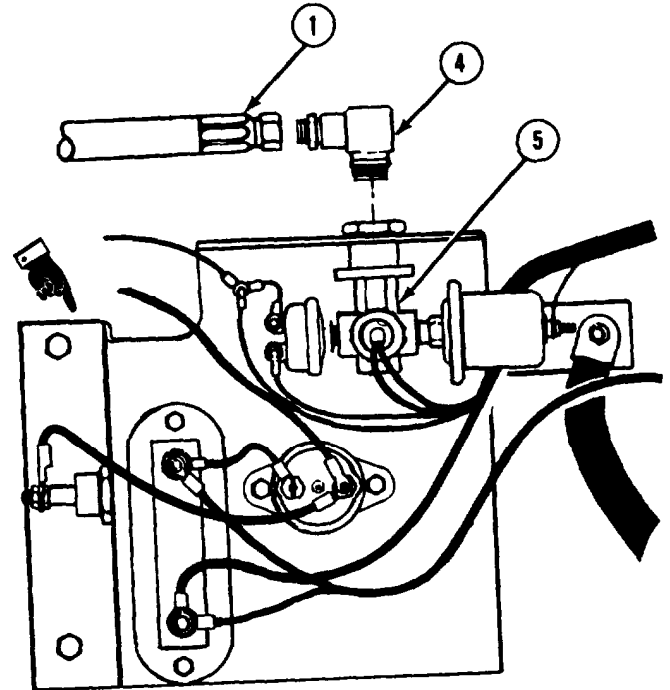
TA185542

- (1) Remove oil manifold hose (1) from elbow (2).
- (2) Remove elbow (2) from engine block (3).

Electrical System Maintenance Instructions (Cont)

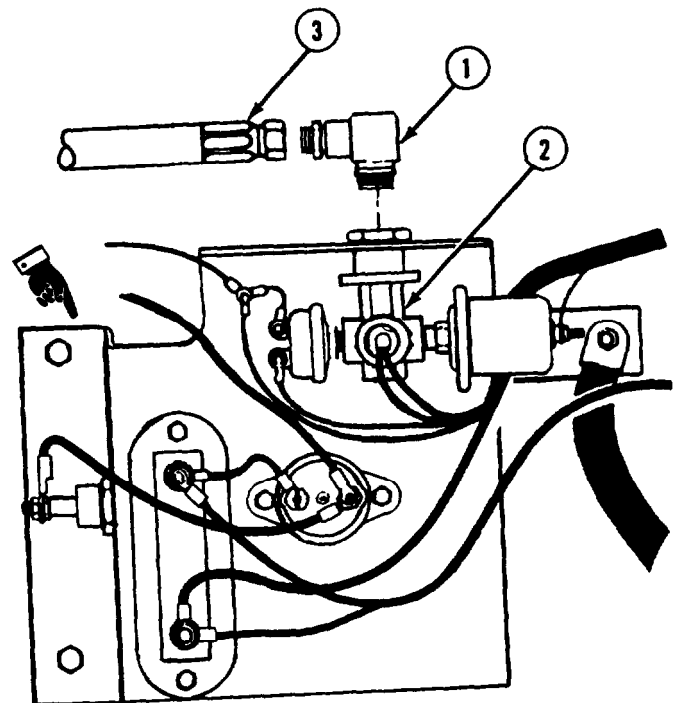
7-83. OIL MANIFOLD HOSE REMOVAL/INSTALLATION (CONT).

- (3) Remove oil manifold hose (1) from elbow (4).
- (4) Remove elbow (4) from oil manifold (5).

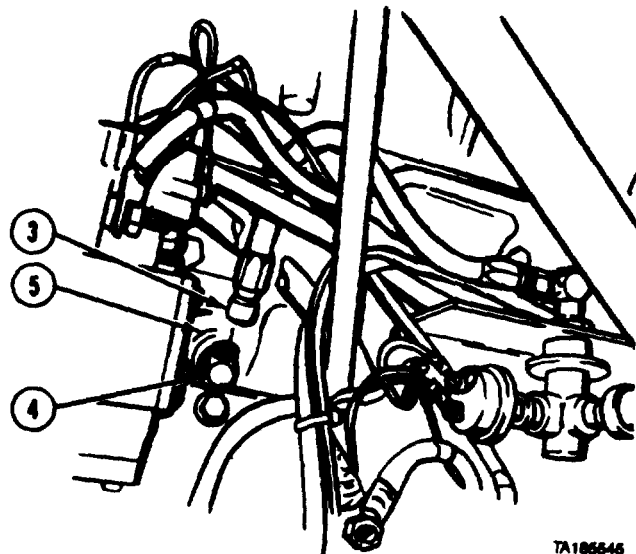
**b. Installation****WARNING**

Adhesives, solvents, and sealing compounds can burn easily, can give off harmful vapors, and are harmful to skin and clothing. To avoid injury or death, keep away from open fire and use in well-ventilated area. If adhesive, solvent, or sealing compound gets on skin or clothing, wash immediately with soap and water.

- (1) Coat threads of elbow (1) with pipe thread sealing compound and install elbow in oil manifold (2).
- (2) Connect oil manifold hose (3) to elbow (1).



Electrical System Maintenance Instructions (Cont)



- (3) Coat threads of elbow (4) with pipe thread sealing compound and install elbow in engine block (5).
- (4) Connect oil manifold hose (3) to elbow (4).

c. Follow-on Maintenance.

- (1) Start engine and check for leaks (TM 9-2320-279-10).
- (2) Shut off engine (TM 9-2320-279-10).
- (3) Install engine side panel (TM 9-2320-279-10).

END OF TASK

Electrical System Maintenance Instructions (Cont)

| | |
|--|--|
| 7-84. OIL PRESSURE SWITCH REMOVAL/INSTALLATION. | |
| This task covers: | |
| a. Removal | c. Follow-on Maintenance |
| b. Installation | |
| INITIAL SETUP | |
| <i>Models</i> | <i>References</i> |
| All | None |
| <i>Test Equipment</i> | <i>Equipment Condition</i> |
| None | <i>TM or Para</i> <i>Condition Description</i> |
| <i>Special Tools</i> | TM 9-2320-279-10 Engine cover open. |
| None | TM 9-2320-279-10 Engine side panel removed. |
| <i>Supplies</i> | Para 7-91 Batteries disconnected. |
| Compound, sealing, pipe thread, Item 18, Appendix C | <i>Special Environmental Conditions</i> |
| Sealant, RTV200 Electrical, Item 45.05, Appendix C | None |
| Tags, identification, Item 48, Appendix C | <i>General Safety Instructions</i> |
| <i>Personnel Required</i> | None |
| MOS 63S, Heavy wheel vehicle mechanic | |

Electrical System Maintenance Instructions (Cont)

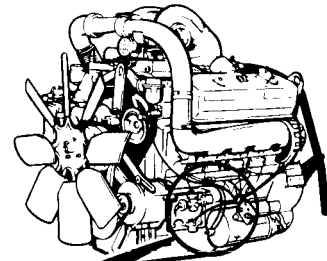
7-84. OIL PRESSURE SWITCH REMOVAL/INSTALLATION (CONT).

a. Removal.

NOTE

Tag and mark wires before removing.

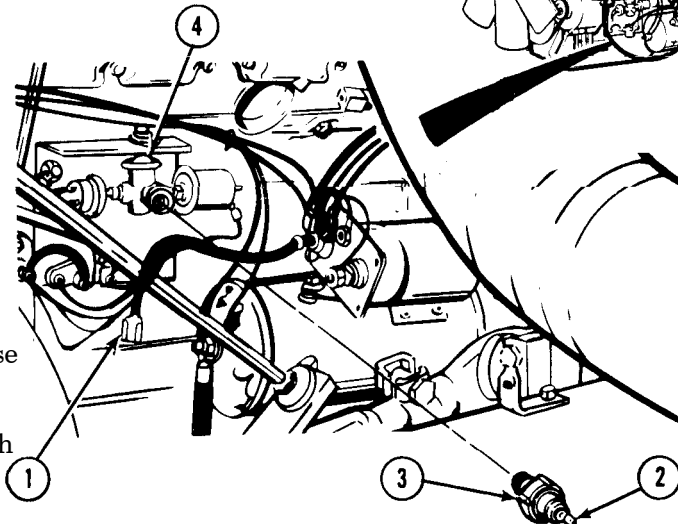
- (1) Disconnect wire (1) from terminal (2) and oil pressure switch (3).
- (2) Remove oil pressure switch (3) from oil manifold (4).



b. Installation.

WARNING

Adhesives, solvents, and sealing compounds can burn easily, can give off harmful vapors, and are harmful to skin and clothing. To avoid injury or death, keep away from open fire and use in well-ventilated area. If adhesive, solvent, or sealing compound gets on skin or clothing, wash immediately with soap and water.



- (1) Coat threads of oil pressure switch (3) with pipe thread sealing compound and install in oil manifold (4).

NOTE

Apply electrical sealant to exposed wire connectors after installing connectors.

- (2) Connect wire (1) on terminal (2) of oil pressure switch (3).

c. Follow-on Maintenance.

- (1) Connect batteries (para 7-91).
- (2) Start engine and check operation of oil pressure switch (TM 9-2320-279-10).
- (3) Check for oil leaks.
- (4) Shut off engine (TM 9-2320-279-10).
- (5) Install engine side panel (TM 9-2320-279-10).
- (6) Close engine cover (TM 9-2320-279-10).

END OF TASK

Electrical System Maintenance Instructions (Cont)

| | |
|--|---|
| 7-85. TRANSMISSION OIL TEMPERATURE SWITCH REMOVAL/INSTALLATION. | |
| This task covers: | |
| a. Removal | c. Follow-on Maintenance |
| b. Installation | |
| INITIAL SETUP | |
| Models | References |
| All | None |
| Test Equipment | Equipment Condition |
| None | TM or Para Condition Description |
| Special Tools | TM 9-2320-279-10 Shut off engine. |
| None | Special Environmental Conditions |
| Supplies | None |
| Compound, sealing, pipe thread, Item 18, Appendix C | General Safety Instructions |
| Personnel Rewired | None |
| MOS 62S Heavy wheel vehicle mechanic | |



Electrical System Maintenance Instructions (Cont)

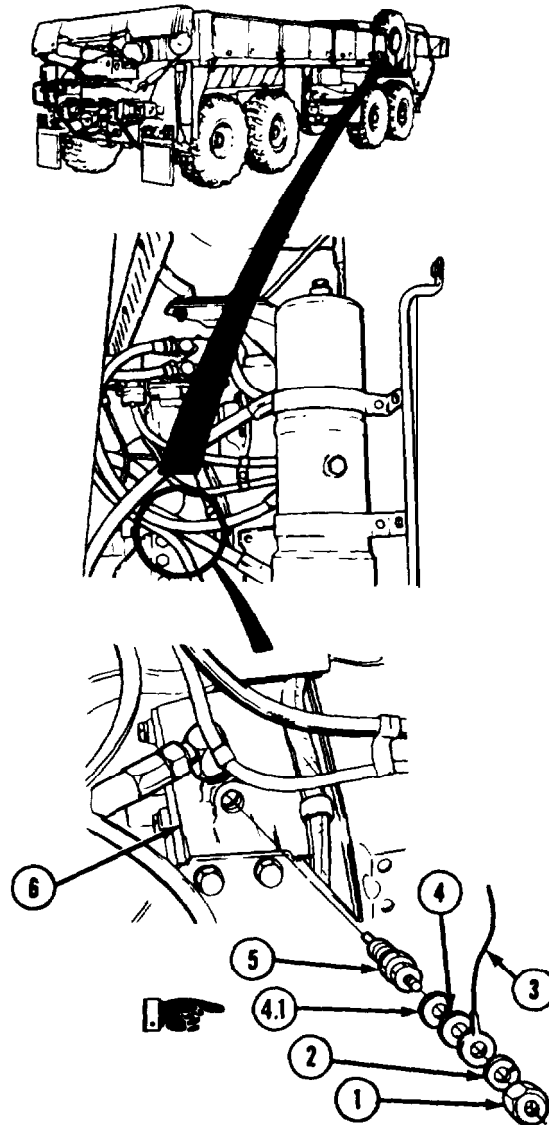
7-85. TRANSMISSION OIL TEMPERATURE SWITCH REMOVAL/INSTALLATION (CONT).

a. Removal.

NOTE

Some models of oil temperature switches contain an insulation washer.

- (1) Remove nut (1), lockwasher (2), wire (3), washer (4), and insulation washer (4.1) (some models) from transmission oil temperature switch (5).
- (2) Remove transmission oil temperature switch (5) from transmission housing (6).



b. Installation.

WARNING

Adhesives, solvents, and sealing compounds can burn easily, can give off harmful vapors, and are harmful to skin and clothing. To avoid injury or death, keep away from open fire and use in well-ventilated area. If adhesive, solvent, or sealing compound gets on skin or clothing, wash immediately with soap and water.

- (1) Coat pipe threads of transmission oil temperature switch (5) with pipe thread sealing compound, and install in transmission housing (6).
- (2) Install insulation washer (4.1) (some models), washer (4), wire (3), lockwasher (2), and nut (1) on transmission oil temperature switch (5). Do not tighten nut more than 20 lb-in (2.26 N•m).

c. Follow-on Maintenance.

- (1) Start engine and check for leaks (TM 9-2320-279-10).
- (2) Drive vehicle, check operation of transmission oil temperature switch (TM 9-2320-279-10).
- (3) Park vehicle (TM 9-2320-279-10).

END OF TASK

Electrical System Maintenance Instructions (Cont)

7-86. TLI TANK LEVEL INDICATOR GAGE AND BRACKET REMOVAL/ INSTALLATION (M978) (TWO STUDS ON BACK OF INDICATOR GAGE).

This task covers:

- a. Removal
- b. Installation
- c. Follow-on Maintenance

INITIAL SETUP

Models

M978 (with two studs on back of TLI tank level indicator gage)

Test Equipment

None

Special Tools

None

Supplies

Tags, identification, Item 48, Appendix C
 Compound, sealing, pipe thread, Item 18, Appendix C
 Adhesive-sealant, silicone, Item 4, Appendix C

Personnel Required

MOS 63S, Heavy wheel vehicle mechanic

References

None

Equipment Condition

| | |
|-------------------|---------------------------------------|
| <i>TM or Para</i> | <i>Condition Description</i> |
| TM 9-2320-279-10 | Pump module rear access doors opened. |
| Para 7-91 | Batteries disconnected. |

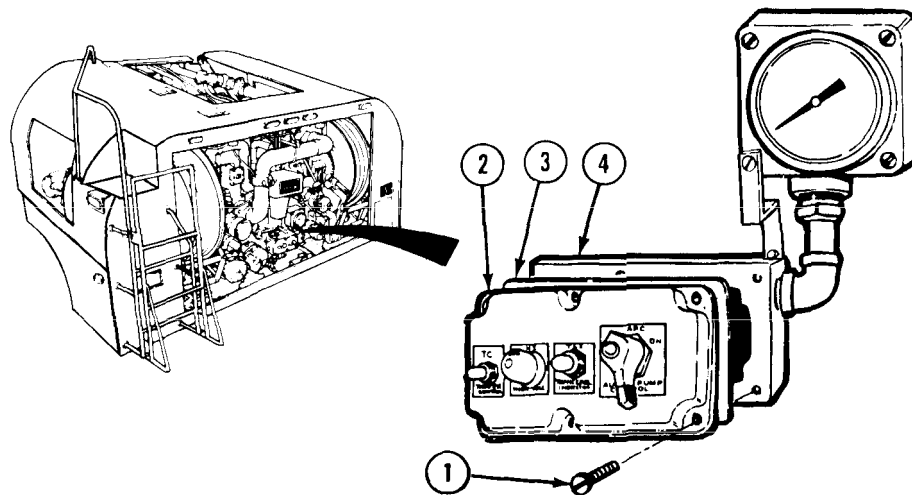
Special Environmental Conditions

None

General Safety Instructions

No smoking, flame, sparks, and hot or glowing objects within 50 ft (15 m) of vehicle.

a. Removal.



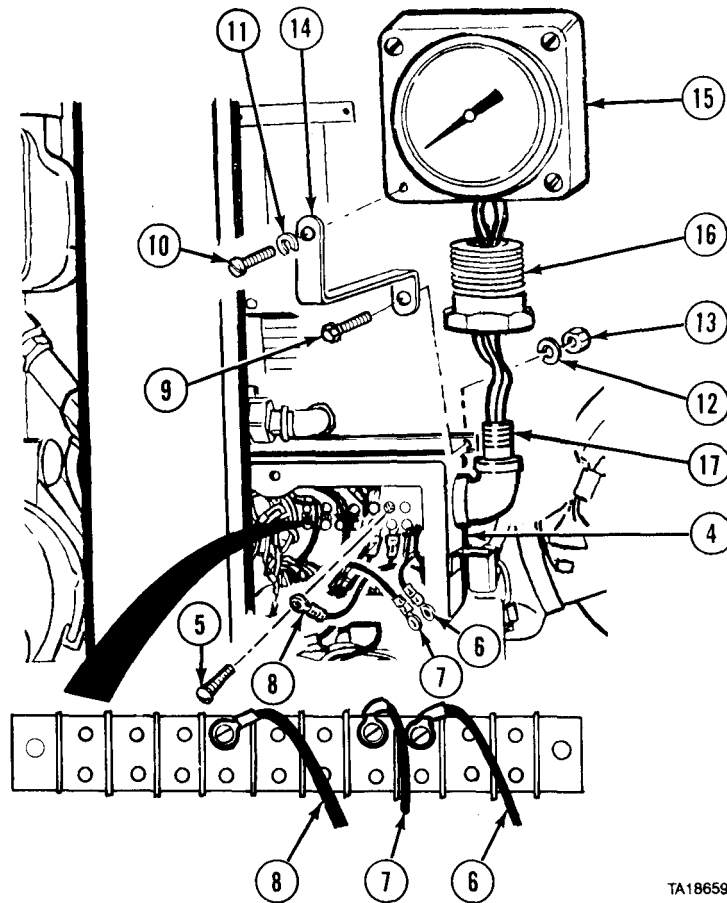
- (1) Remove six screws (1), cover (2), and gasket (3) from junction box (4).

Electrical System Maintenance Instructions (Cont)

NOTE

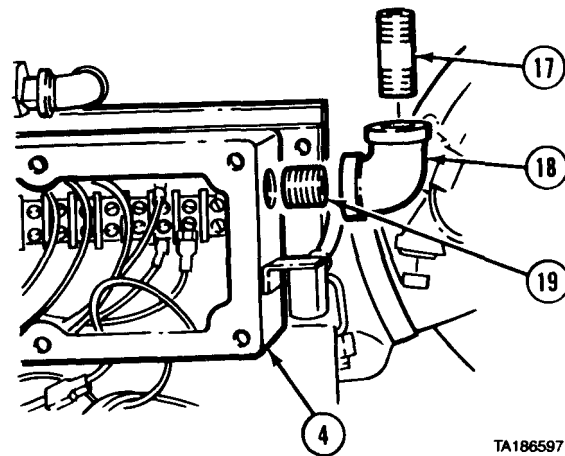
Tag and mark all wires before disconnecting.

- (2) Remove three screws (5) and wires (6, 7, and 8) from control junction box (4).
- (3) Remove two screws (9 and 10), lockwashers (11 and 12), nut (13), and bracket (14).
- (4) Remove indicator box (15) with adapter (16) from pipe nipple (17).
- (5) Remove adapter (16) from indicator box (15).



TA186596

- (6) Remove pipe nipple (17), elbow (18), and pipe nipple (19) from junction box (4).

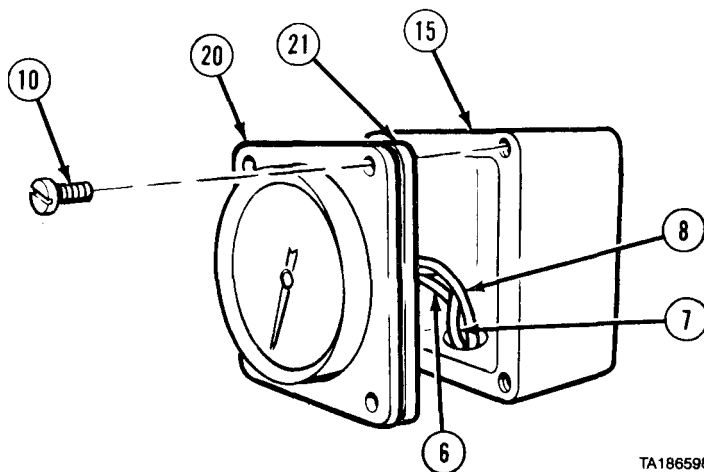


TA186597

Electrical System Maintenance Instructions (Cont)

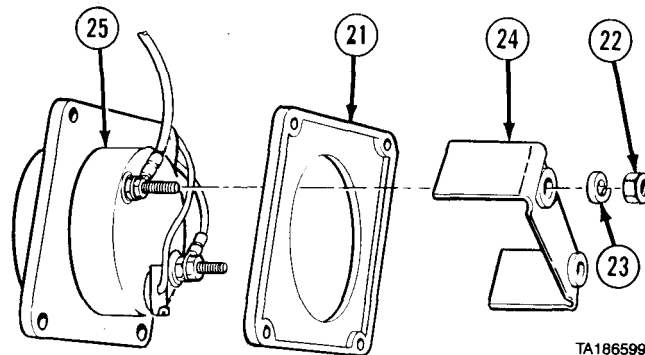
7-86. TLI TANK LEVEL INDICATOR GAGE AND BRACKET REMOVAL/INSTALLATION (M978) (CONT).

- (7) Remove three screws (10), cover (20), gasket (21), and pull three wires (6, 7, and 8) from indicator box (15).



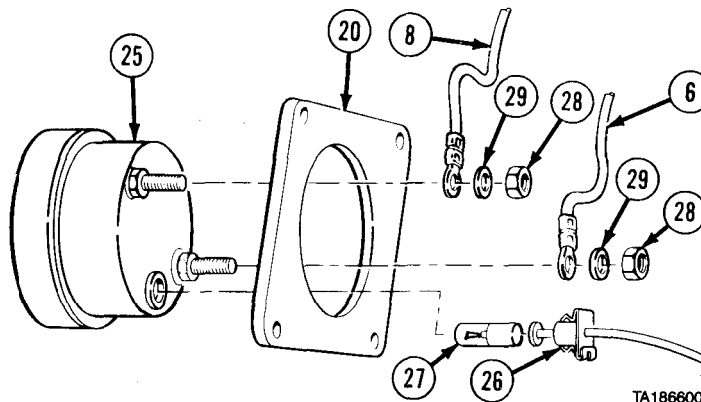
TA186598

- (8) Remove two nuts (22), lockwashers (23), bracket (24), and gasket (21) from TLI TANK LEVEL INDICATOR gage (25).



TA186599

- (9) Remove clip socket (26) from gage (25).
- (10) Remove lamp (27) from clip socket (26).
- (11) Remove two nuts (28), washers (29), and wires (6 and 8) from TLI TANK LEVEL INDICATOR gage (25).
- (12) Remove TLI TANK LEVEL INDICATOR gage (25) from cover (20).

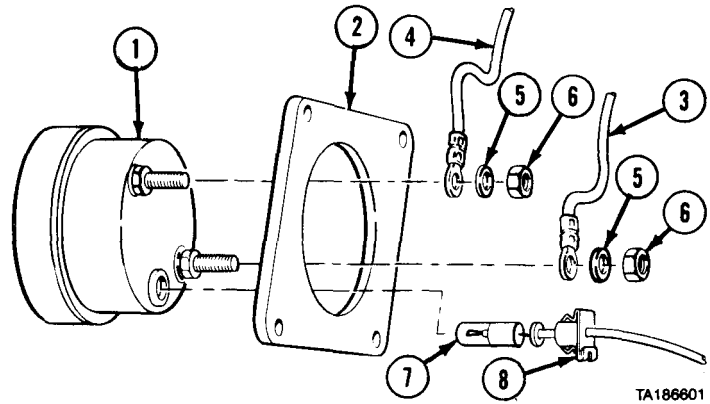


TA186600

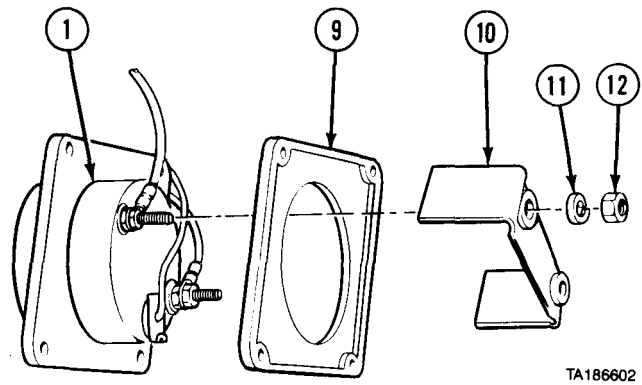
Electrical System Maintenance Instructions (Cont)

b. Installation.

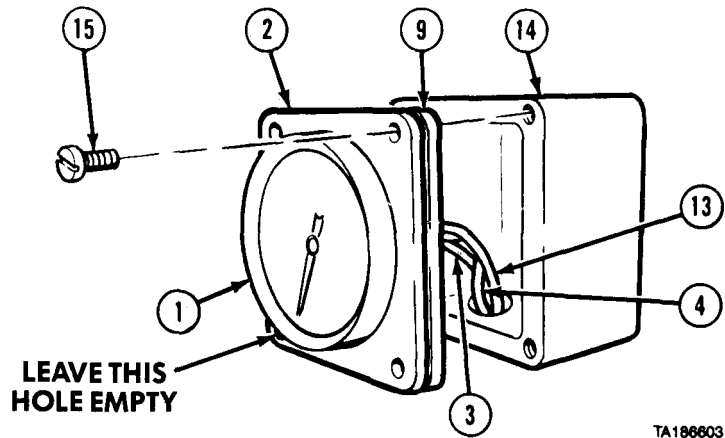
- (1) Position TLI TANK LEVEL INDICATOR gage (1) in cover (2) and install wire (3) and wire (4) with washers (5) and nuts (6).
- (2) Install lamp (7) in clip socket (8).
- (3) Install clip socket (8) in TLI TANK LEVEL INDICATOR gage (1).



- (4) Install gasket (9) and bracket (10) on TLI TANK LEVEL INDICATOR gage (1) with two lockwashers (11) and nuts (12).



- (5) Install three wires (3, 4, and 13) through indicator box (14).
- (6) Install TLI TANK LEVEL INDICATOR gage (1), cover (2), and gasket (9) with three screws (15).



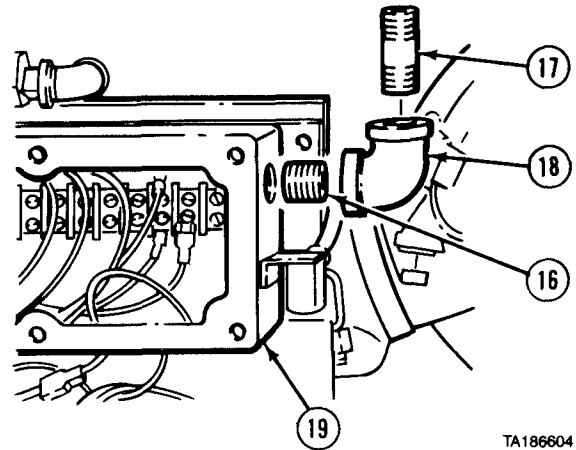
Electrical System Maintenance Instructions (Cont)

7-86. TLI TANK LEVEL INDICATOR GAGE AND BRACKET REMOVAL/INSTALLATION (M978)
(CONT).

WARNING

Adhesives, solvents, and sealing compounds can burn easily, can give off harmful vapors, and are harmful to skin and clothing. To avoid injury or death, keep away from open fire and use in well-ventilated area. If adhesive, solvent, or sealing compound gets on skin or clothing, wash immediately with soap and water.

- (7) Coat threads of pipe nipples (16 and 17) with pipe thread sealing compound and install into elbow (18) and junction-box (19).

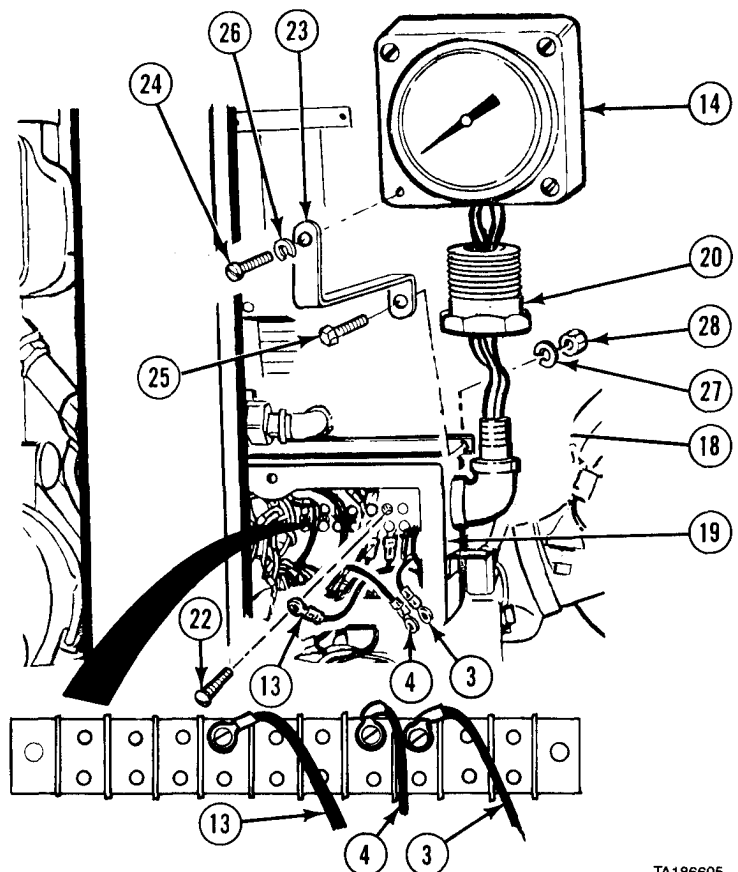


TA186604

CAUTION

To avoid damage to wires, do not connect wires until indicator box has been installed on pipe.

- (8) Install adapter (20) in indicator box (14) and feed wire (3), wire (4), and wire (13) into control junction box (19).
- (9) Apply pipe thread sealing compound to threads of pipe nipple (18) and install adapter (20) and indicator box (14) on pipe.
- (10) Install three wires (3, 4, and 13) and three screws (22).
- (11) Install bracket (23) with two screws (24 and 25), lockwashers (26 and 27), and nut (28).



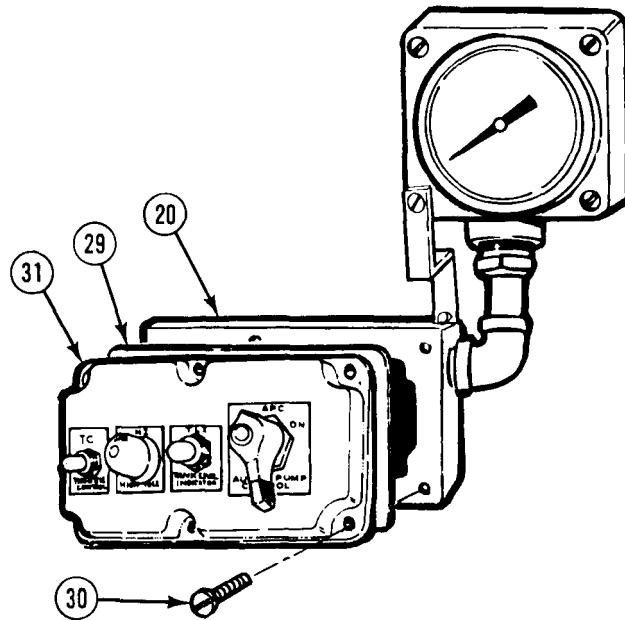
TA186605

Electrical System Maintenance Instructions (Cont)

- (12) Apply silicone adhesive-sealant to both sides of gasket (29).
- (13) Apply pipe thread sealing compound to threads of six screws (30) and install gasket (29) and cover (31) on control junction box (20) with screws (30).

c. Follow-on Maintenance.

- (1) Connect batteries (para 7-91).
- (2) Check tank fuel level (TM 9-2320-279-10).
- (3) Adjust TLI TANK LEVEL INDICATOR gage (para 7-87).



END OF TASK

Electrical System Maintenance Instructions (Cont)

7-86.1. TLI TANK LEVEL INDICATOR GAGE AND BRACKET REMOVAL/INSTALLATION (M978) (FIVE STUDS ON BACK OF INDICATOR GAGE).

This task covers:

- a. Removal
- b. Installation
- c. Follow-on Maintenance

INITIAL SETUP

Models

M978 (with five studs on back of TLI tank level indicator gage)

Test Equipment

None

Special Tools

None

Supplies

Tags, identification, Item 48, Appendix C
 Compound, sealing, pipe thread, Item 18, Appendix C
 Adhesive-sealant, silicone, Item 4, Appendix C

Personnel Required

MOS 63S, Heavy wheel vehicle mechanic

References

None

Equipment Condition

| | |
|-------------------|---------------------------------------|
| <i>TM or Para</i> | <i>Condition Description</i> |
| TM 9-2320-279-10 | Pump module rear access doors opened. |
| Para 7-91 | Batteries disconnected. |

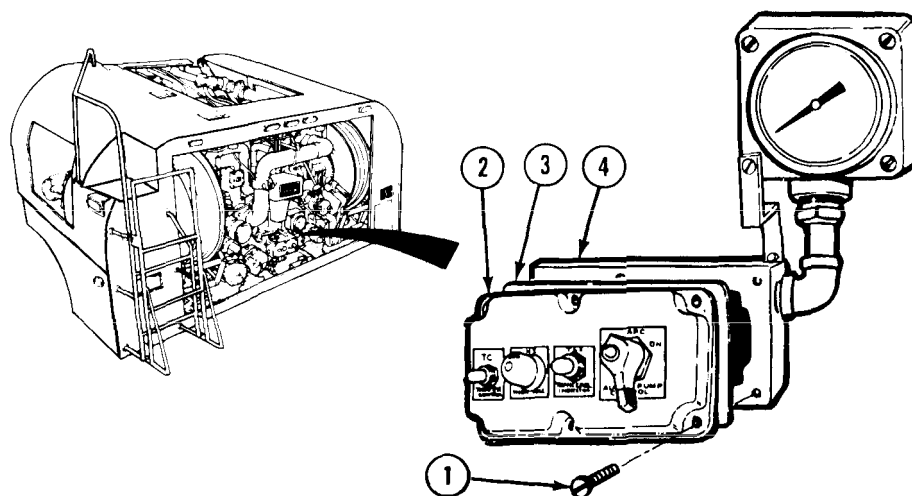
Special Environmental Conditions

None

General Safety Instructions

No smoking, flame, sparks, and hot or glowing objects within 50 ft (15 m) of vehicle.

a. Removal.



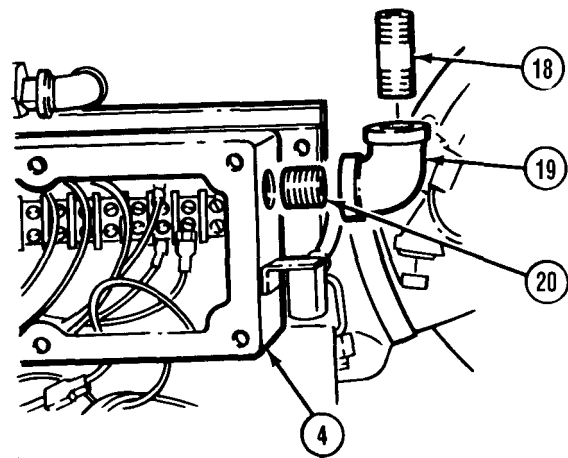
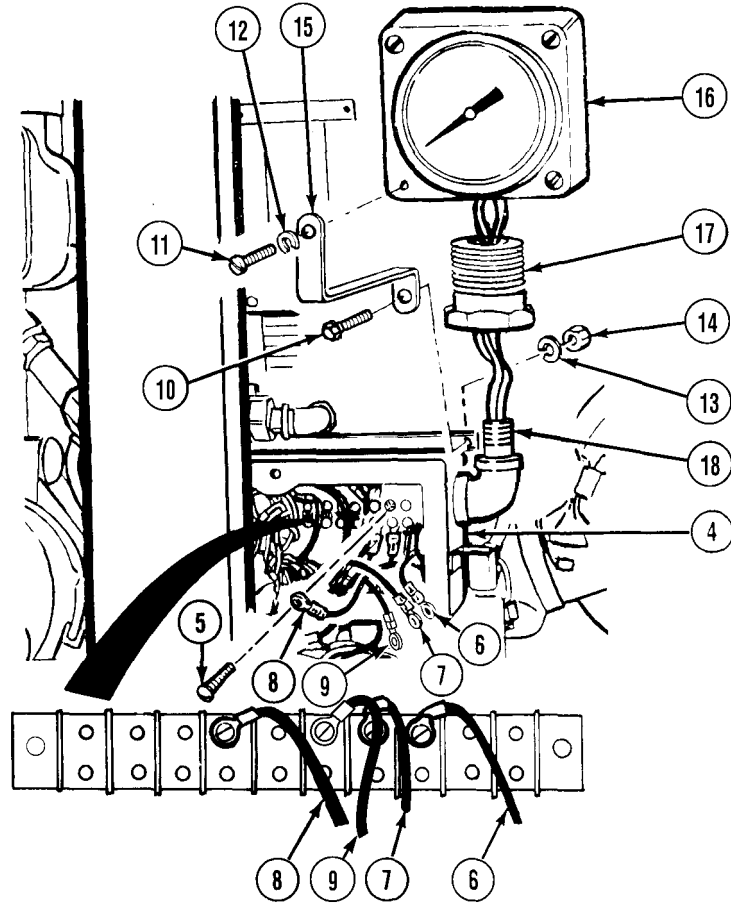
- (1) Remove six screws (1), cover (2), and gasket (3) from junction box (4).

Electrical System Maintenance Instructions (Cont)

7-86.1. TLI TANK LEVEL INDICATOR GAGE AND BRACKET REMOVAL/INSTALLATION (M978) (CONT).

NOTE

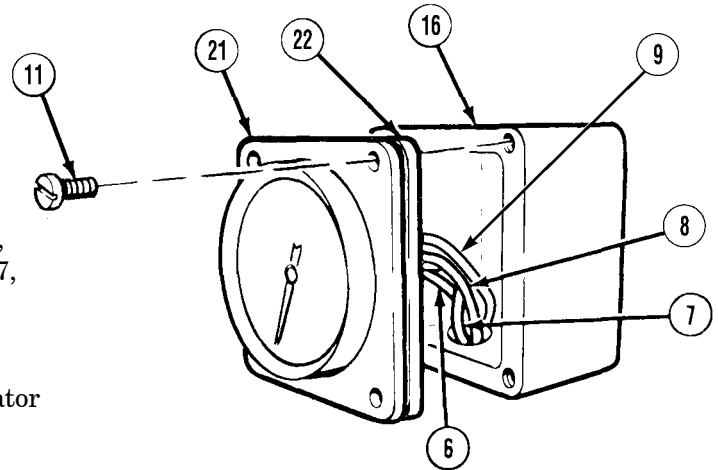
- Tag and mark all wires before disconnecting.
 - There are two models of vehicle when performing this procedure.
 - Model B incorporates a blue ground wire to the gage. Model A does not incorporate this blue ground wire.
 - Perform step (2) if working on a Model A vehicle.
 - Perform step (3) if working on a Model B vehicle.
- (2) Remove three screws (5) and wires (6, 7, and 8) from control junction box (4).
 - (3) Remove four screws (5) and wires (6, 7, 8, and 9) from control junction box (4).
 - (4) Remove two screws (10 and 11), lockwashers (12 and 13) (Model A only), nut (14), and bracket (15).
 - (5) Remove indicator box (16) with adapter (17) from pipe nipple (18).
 - (6) Remove adapter (17) from indicator box (16).
 - (7) Remove pipe nipple (18), elbow (19), and pipe nipple (20) from control junction box (4).



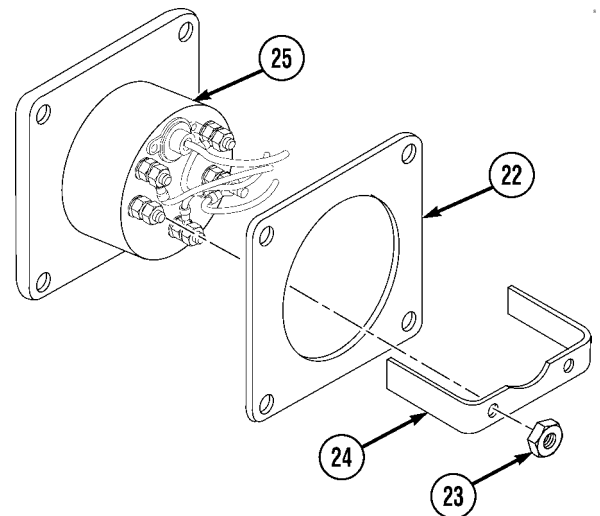
Electrical System Maintenance Instructions (Cont)

NOTE

- Perform step (8) if working on a Model A vehicle.
 - Perform step (9) if working on a Model B vehicle.
- (8) Remove three screws (11), cover (21), gasket (22), and pull three wires (6, 7, and 8) from indicator box (16).
- (9) Remove three screws (11), cover (21), gasket (22), and pull four wires (6, 7, 8, and 9) from indicator box (16).



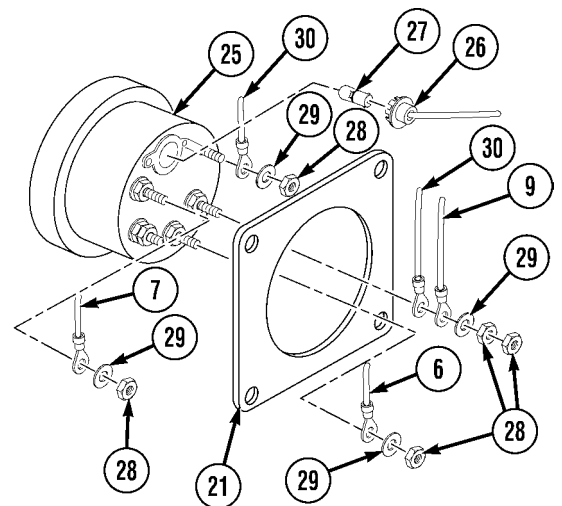
- (10) Remove two nuts (23), bracket (24), and gasket (22) from TLI TANK LEVEL INDICATOR gage (25).



- (11) Remove clip socket (26) from gage (25).
- (12) Remove lamp (27) from clipsocket (26).

NOTE

- Perform step (13) if working on a Model A vehicle.
 - Perform step (14) if working on a Model B vehicle.
- (13) Remove five nuts (28), four washers (29), and three wires (6, 7, and 30) from TLI TANK LEVEL INDICATOR gage (25).
- (14) Remove five nuts (28), four washers (29), and wires (6, 7, 9, and 30) from TLI TANK LEVEL INDICATOR gage (25).
- (15) Remove TLI TANK LEVEL INDICATOR gage (25) from cover (21).



Electrical System Maintenance Instructions (Cont)

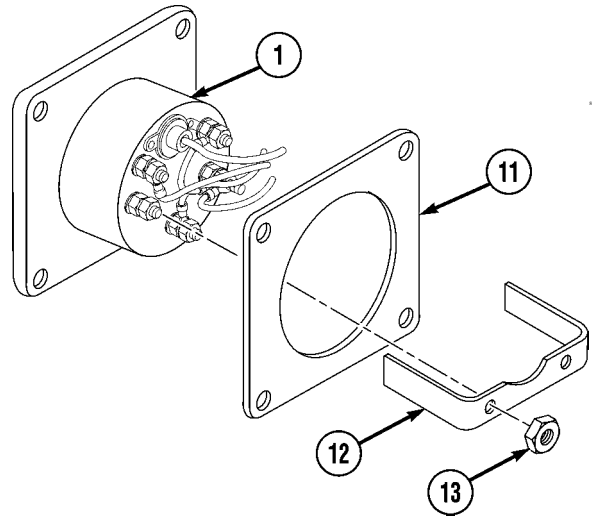
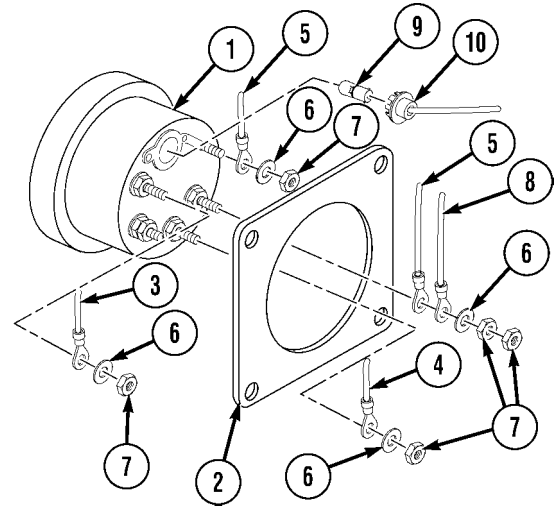
7-86.1. TLI TANK LEVEL INDICATOR GAGE AND BRACKET REMOVAL/INSTALLATION (M978) (CONT).

b. Installation.

NOTE

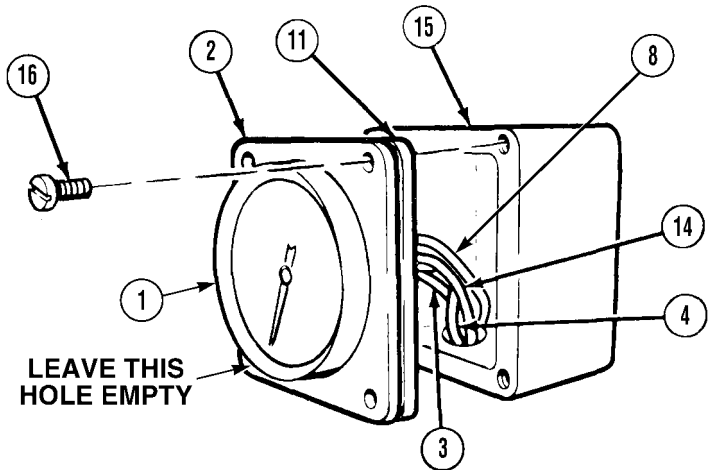
- There are two models of vehicle when performing this procedure.
- Model B incorporates a blue ground wire to the gage. Model A does not incorporate this blue ground wire.
- Perform step (1) if working on a Model A vehicle.
- Perform step (2) if working on a Model B vehicle.

- (1) Position TLI TANK LEVEL INDICATOR gage (1) in cover (2) and install three wires (3, 4, and 5) with four washers (6) and five nuts (7).
- (2) Position TLI TANK LEVEL INDICATOR gage (1) in cover (2) and install four wires (3, 4, 5, and 8) with washers (6) and five nuts (7).
- (3) Install lamp (9) in clip socket (10).
- (4) Install clip socket (10) in TLI TANK LEVEL INDICATOR gage (1).
- (5) Install gasket (11) and bracket (12) on TLI TANK LEVEL INDICATOR gage (1) with two nuts (13).



NOTE

- Perform step (6) if working on a Model A vehicle.
 - Perform step (7) if working on a Model B vehicle.
- (6) Install three wires (3, 4, and 14) through indicator box (15).
 - (7) Install four wires (3, 4, 8, and 14) through indicator box (15).
 - (8) Install TLI TANK LEVEL INDICATOR gage (1), cover (2), and gasket (11) with three screws (16).

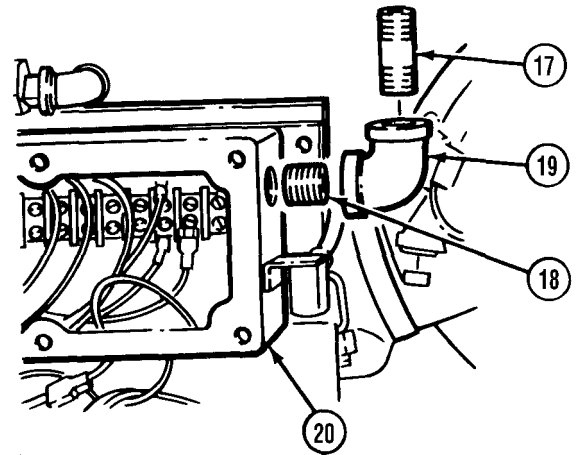


Electrical System Maintenance Instructions (Cont)

WARNING

Adhesives, solvents, and sealing compounds can burn easily, can give off harmful vapors, and are harmful to skin and clothing. To avoid injury or death, keep away from open fire and use in well-ventilated area. If adhesive, solvent, or sealing compound gets on skin or clothing, wash immediately with soap and water.

- (9) Coat threads of pipe nipples (17 and 18) with pipe thread sealing compound and install into elbow (19) and control junction box (20).

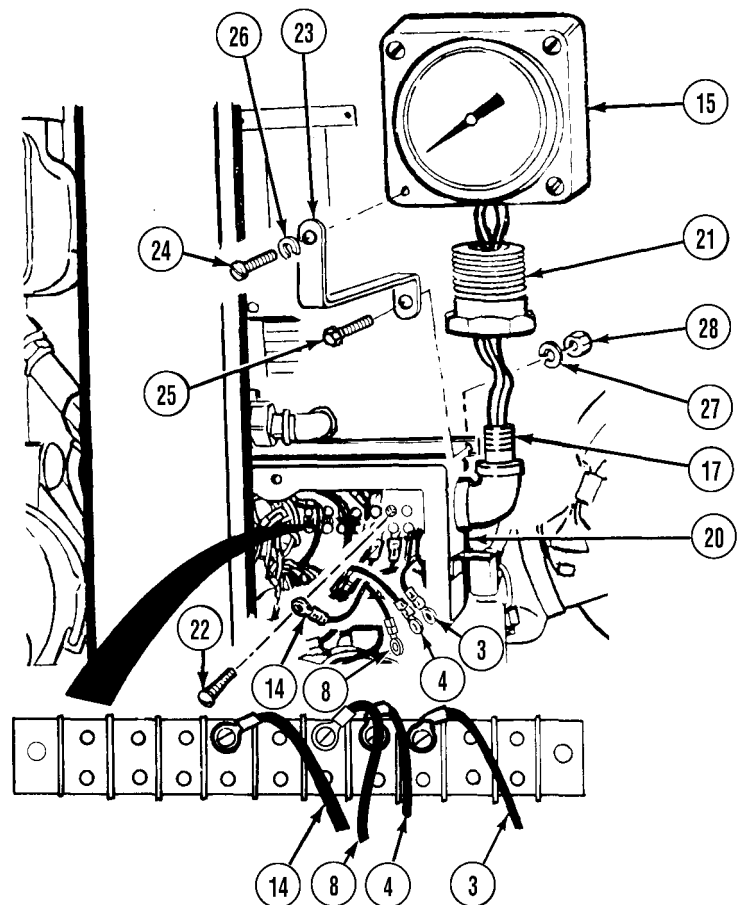


CAUTION

To avoid damage to wires, do not connect wires until indicator box has been installed on pipe.

NOTE

- Perform step (10) if working on a Model A vehicle.
- Perform step (11) if working on a Model B vehicle.
- (10) Install adapter (21) in indicator box (15) and feed three wires (3, 4, and 13) into control junction box (20).
- (11) Apply pipe thread sealing compound to threads of pipe nipple (17) and install adapter (21) and indicator box (15) on pipe nipple (17).



NOTE

- Perform step (12) if working on a Model A vehicle.
- Perform step (13) if working on a Model B vehicle.
- (12) Install three wires (3, 4, and 13) and three screws (22).
- (13) Install four wires (3, 4, 8, and 14) and four screws (22).
- (14) Install bracket (23) with two screws (24 and 25), lockwashers (26 and 27) (Model A only) and nut (28).

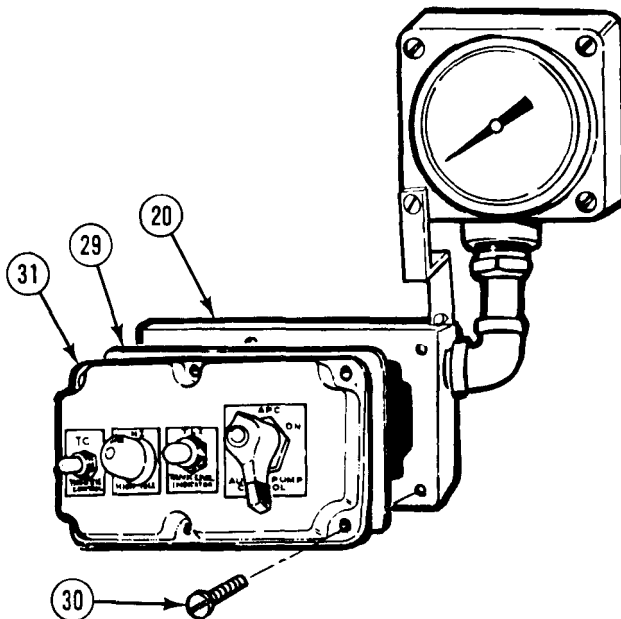
Electrical System Maintenance Instructions (Cont)

7-86.1. TLI TANK LEVEL INDICATOR GAGE AND BRACKET REMOVAL/INSTALLATION (M978) (CONT).

- (15) Apply silicone adhesive-sealant to both sides of gasket (29).
- (16) Apply pipe thread sealing compound to threads of six screws (30) and install gasket (29) and cover (31) on control junction box (20) with screws (30).

c. Follow-on Maintenance.

- (1) Connect batteries (para 7-91).
- (2) Check tank fuel level (TM 9-2320-279-10).
- (3) Adjust TLI TANK LEVEL INDICATOR gage (para 7-87).



END OF TASK

7-87. TANK LEVEL INDICATOR ADJUSTER REMOVAL/INSTALLATION/ADJUSTMENT (M978).

This task covers:

- a. Removal
- b. Installation
- c. Adjustment
- d. Follow-on Maintenance

INITIAL SETUP

Models
M978

Test Equipment
None

Special Tools
None

Supplies
Adhesive-sealant, silicone, Item 4, Appendix C
Compound, sealing, pipe thread, Item 18, Appendix C
Tags, identification, Item 48, Appendix C

Personnel Required
MOS 63S, Heavy wheel vehicle mechanic (3)

References
None

Equipment Condition

| | |
|-------------------|---|
| <i>TM or Para</i> | <i>Condition Description</i> |
| Para 7-91 | Batteries disconnected. |
| TM 9-2320-279-10 | Pump module rear access doors opened. |
| Para 16-48 | Pump module left side access panel removed. |

Special Environmental Conditions
None

General Safety Instructions
No smoking, flame, sparks, and hot or glowing objects within 50 ft (15 m) of vehicle.

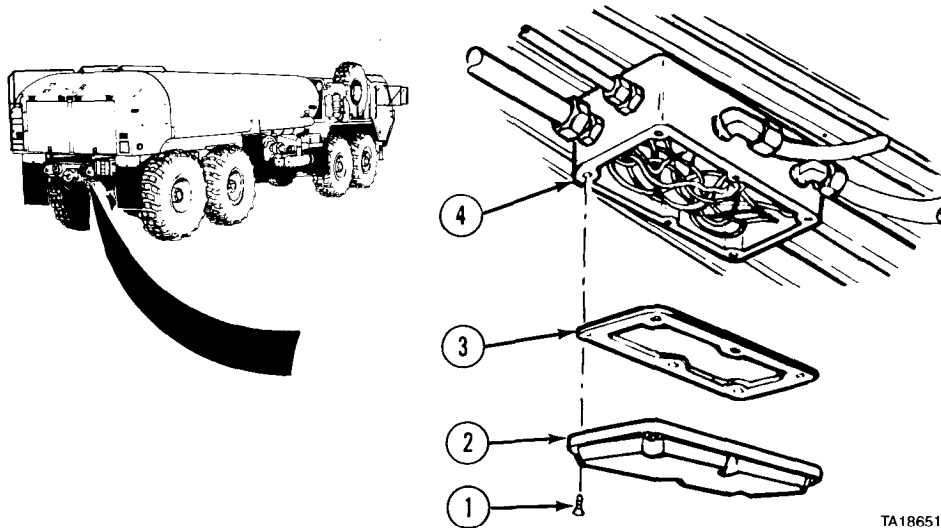
Electrical System Maintenance Instructions (Cont)

7-87. TANK LEVEL INDICATOR ADJUSTER REMOVAL/INSTALLATION/ADJUSTMENT (M978)
(CONT).

a. Removal.

NOTE

There are two kinds of tank level indicator adjusters. Model A has one adjustment screw and is used only with the plastic fuel level sensor. Model B has four adjustment screws and is used only with the brass fuel level sensor. If the tank level indicator adjuster must be replaced and one of the same models is not available, the fuel level sensor must also be replaced. Refer to TM 9-2320-279-20P for proper parts identification.

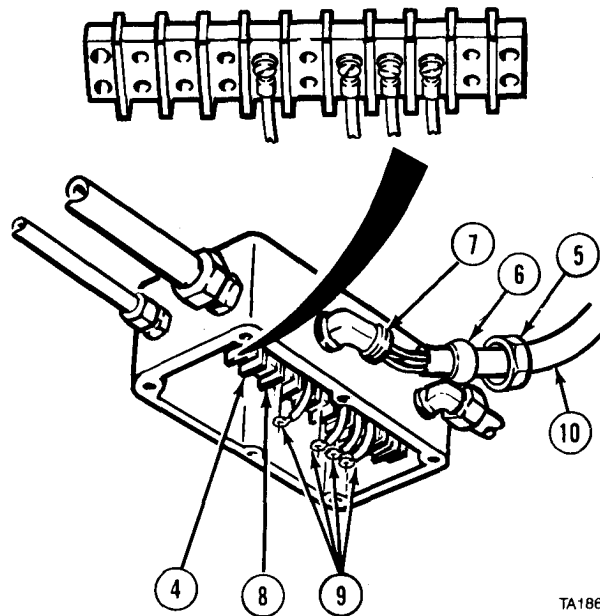


- (1) Remove six screws (1), cover (2), and gasket (3) from main junction box (4).

NOTE

Tag and mark all wires before removing.

- (2) Loosen nut (5) and compression fitting (6) from elbow (7).
- (3) Loosen four screws (8) and disconnect four wires (9) from main junction box (4).
- (4) Pull hose (10) and four wires (9) from main junction box (4).



Electrical System Maintenance Instructions (Cont)

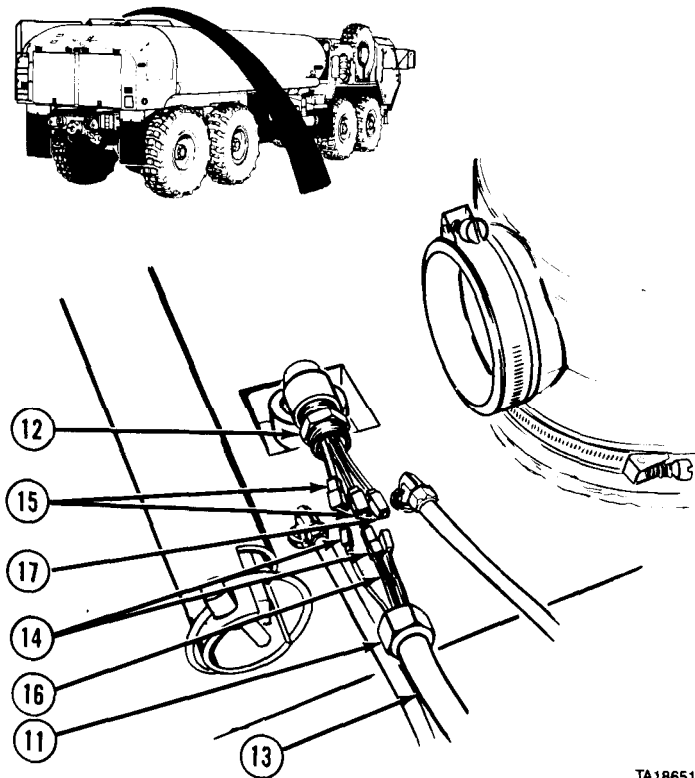
- (5) Loosen nut (11) from adapter (12) and pull hose (13) free.

NOTE

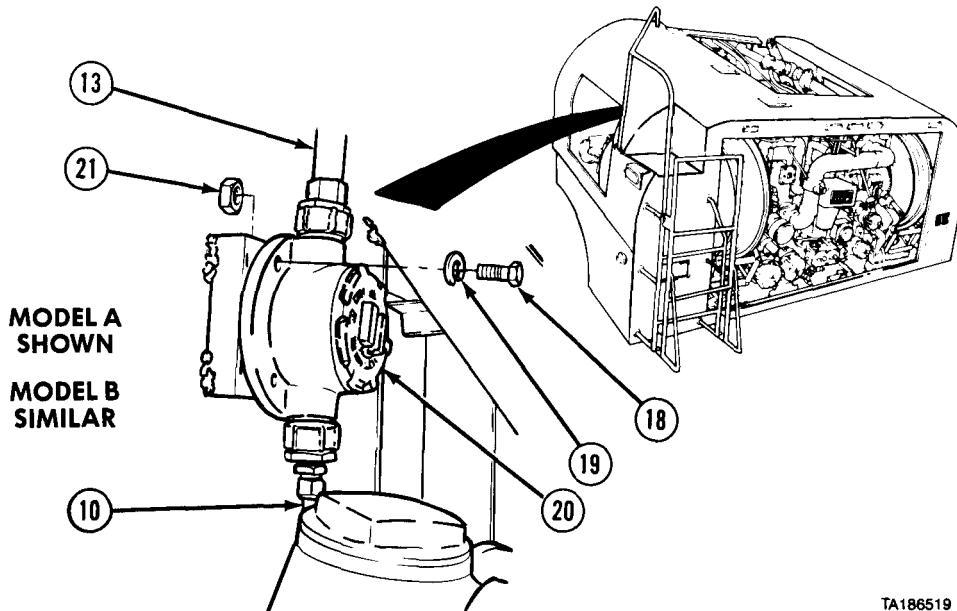
- Model A has three connectors and wires.
- Model B has two connectors and wires.

- (6) Disconnect two wires (14) at connectors (15) and one wire (16) at connector (17).

**MODEL A
SHOWN
MODEL B
SIMILAR**



TA186518



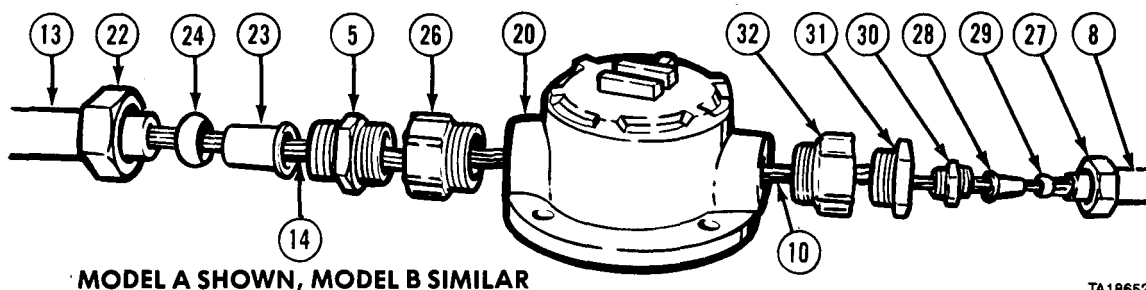
**MODEL A
SHOWN
MODEL B
SIMILAR**

TA186519

- (7) Remove two screws (18), lockwasher (19), tank level indicator adjuster (20), locknuts (21), and hoses (10 and 13).

Electrical System Maintenance Instructions (Cont)

7-87. TANK LEVEL INDICATOR ADJUSTER REMOVAL/INSTALLATION/ADJUSTMENT (M978) (CONT).

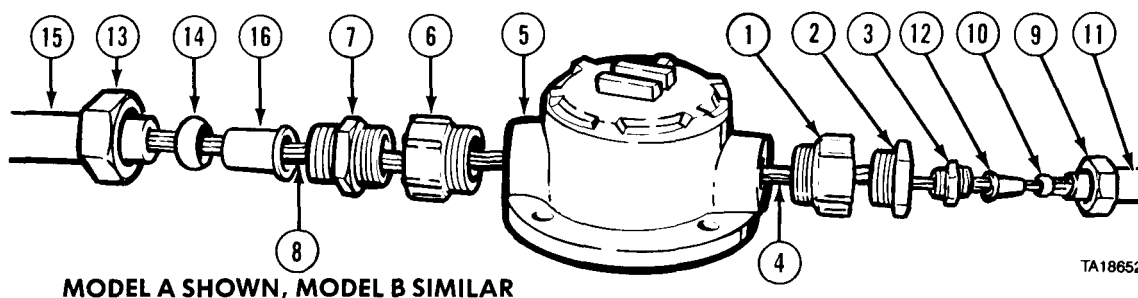


NOTE

Both ends of hoses are removed the same way.

- (8) Remove nut (22), hose (13), insert (23), compression fitting (24), adapter (25), and fitting (26) from wires (14) and tank level indicator adjuster (20).
- (9) Remove nut (27), hose (8), insert (28), compression fitting (29), adapter (30), adapter (31), and fitting (32) from wires (10) and tank level indicator adjuster (20).

b. Installation.



WARNING

Adhesives, solvents, and sealing compounds can burn easily, can give off harmful vapors, and are harmful to skin and clothing. To avoid injury or death, keep away from open fire and use in well-ventilated area. If adhesive, solvent, or sealing compound gets on skin or clothing, wash immediately with soap and water.

- (1) Apply pipe thread sealing compound and install fitting (1), adapter (2), and adapter (3) over wires (4) and on tank level indicator adjuster (5).
- (2) Apply pipe thread sealing compound and install fitting (6) and adapter (7) over wires (8) and on tank level indicator adjuster (5).

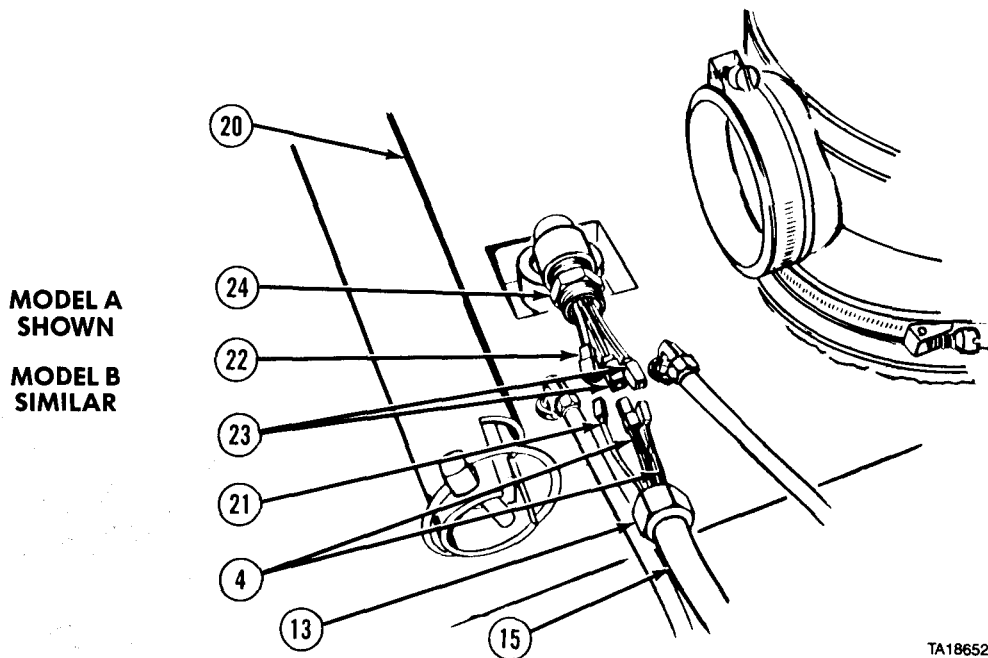
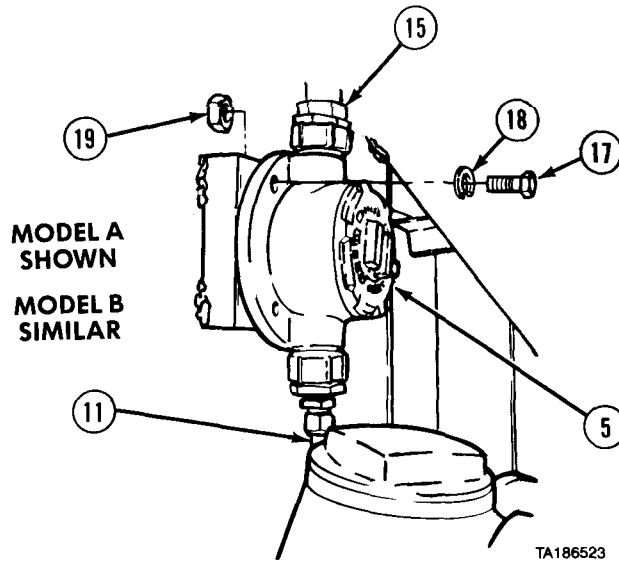
NOTE

Both ends of hoses are installed the same way.

- (3) Install nut (9) and compression fitting (10) on hose (11) and install insert (12).
- (4) Thread wires (4) through hose (11) and install nut (9) on adapter (3).
- (5) Install nut (13) and compression fitting (14) on hose (15) and install insert (16).
- (6) Thread wires (8) through hose (15) and install nut (13) on adapter (7).

Electrical System Maintenance Instructions (Cont)

- (7) Install tank level indicator (5) and hoses (11 and 15) with two screws (17), lockwashers (18), and locknuts (19).



NOTE

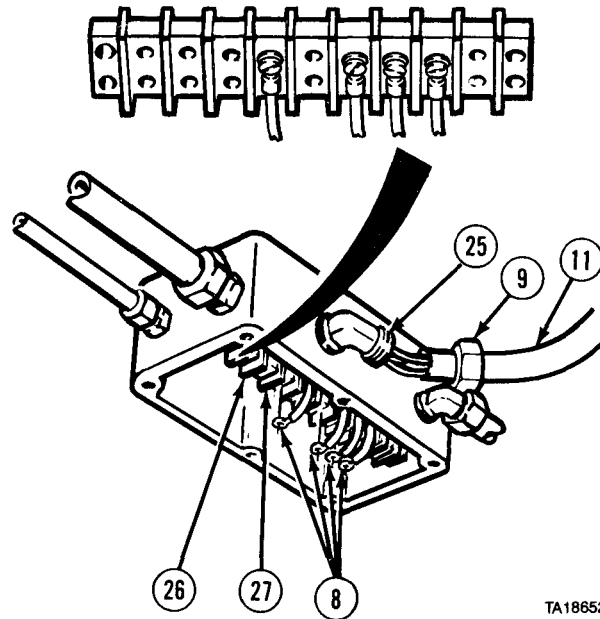
- Model A has three connectors and wires.
- Model B has two connectors and wires.

- (8) Route hose (15) to top of tank (20) and connect two wires (4) and wire (21) on three connectors (22 and 23).

- (9) Install hose (15) on adapter (24) with nut (13).

Electrical System Maintenance Instructions (Cont)

7-87. TANK LEVEL INDICATOR ADJUSTER REMOVAL/INSTALLATION/ADJUSTMENT (M978)
(CONT).



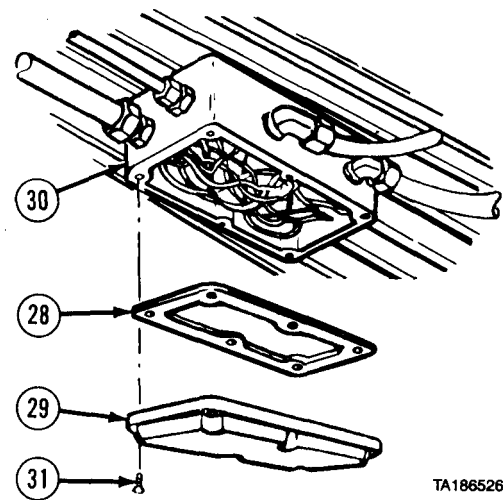
TA186525

- (10) Install hose (11) on elbow (25). Tighten nut (9).
- (11) Install four wires (8) on terminal board (26) with four screws (27).

WARNING

Adhesives, solvents, and sealing compounds can burn easily, can give off harmful vapors, and are harmful to skin and clothing. To avoid injury or death, keep away from open fire and use in well-ventilated area. If adhesive, solvent, or sealing compound gets on skin or clothing, wash immediately with soap and water.

- (12) Coat gasket (28) with silicone adhesive-sealant.
- (13) Install gasket (28) and cover (29) on main junction box (30) with six screws (31).



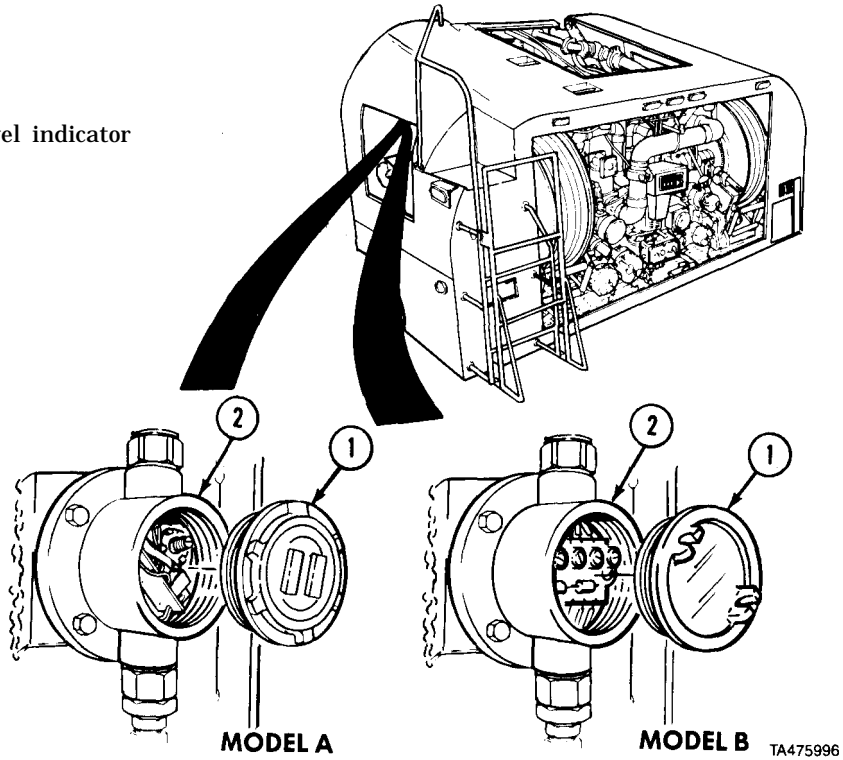
TA186526

Electrical System Maintenance Instructions (Cont)

c. Adjustment.

(1) Connect batteries (para 7-91).

(2) Remove cap (1) from tank level indicator adjuster (2).

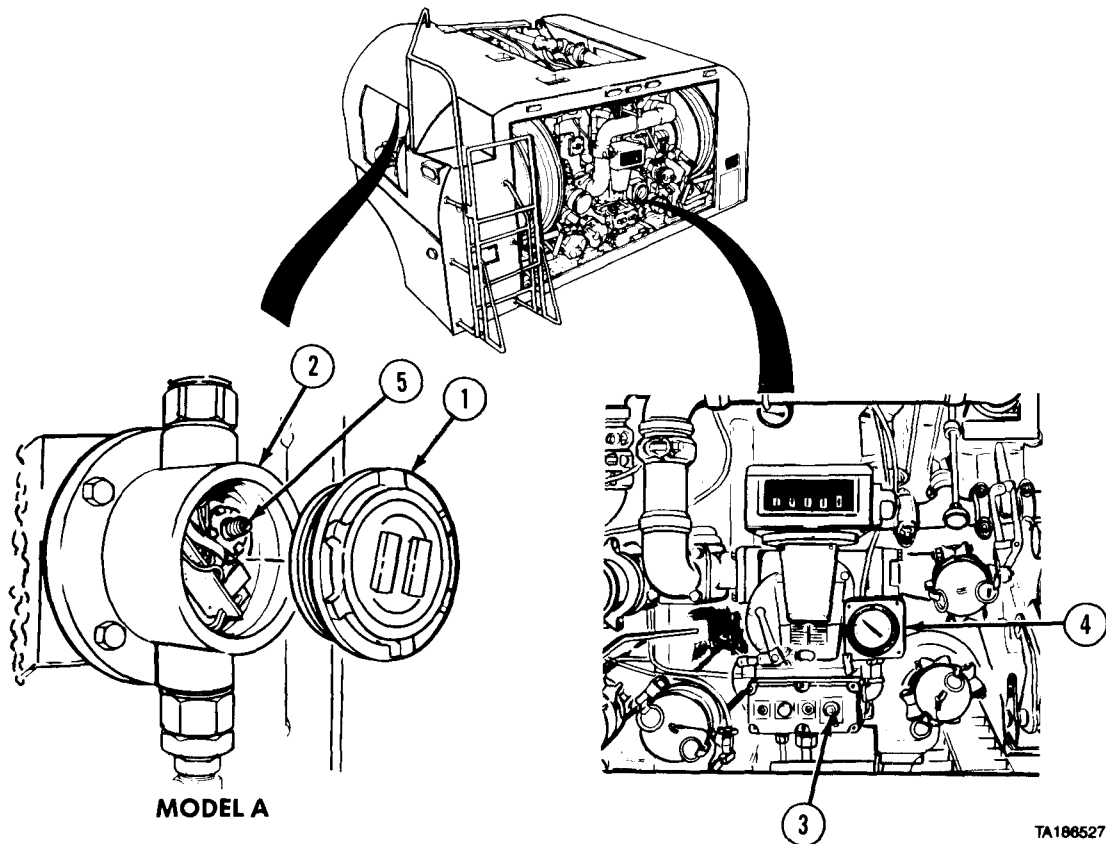


NOTE

There are two kinds of tank level indicator adjusters. Model A has only one adjustment screw. Model B has four adjustment screws. Do steps (3) through (7) for Model A. Do steps (8) through (19) for Model B.

Electrical System Maintenance Instructions (Cont)

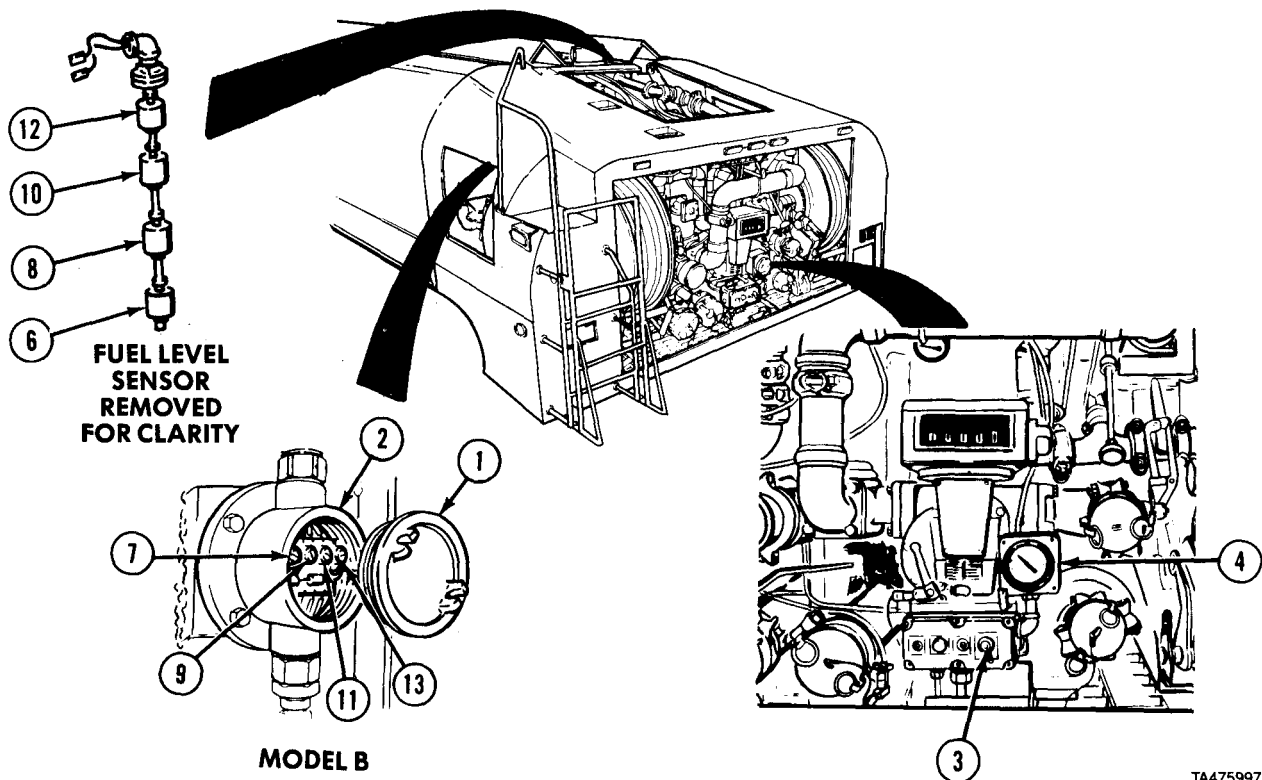
7-87. TANK LEVEL INDICATOR ADJUSTER REMOVAL/INSTALLATION/ADJUSTMENT (M978)
(CONT).



TA186527

- (3) Connect batteries (para 7-91).
- (4) Load tanker with fuel (TM 9-2320-279-10).
- (5) Soldier A sets TLI TANK LEVEL INDICATOR switch (3) on and watches TLI TANK LEVEL INDICATOR gage (4) while Soldier B turns screw (5). When TLI TANK LEVEL INDICATOR gage (4) needle indicates FULL, Soldier A tells Soldier B to stop turning screw (5).
- (6) Set TLI TANK LEVEL INDICATOR switch (3) off.
- (7) Install cap (1) on tank level indicator adjuster (2).

Electrical System Maintenance Instructions (Cont)



MODEL B

TA475997

- (8) Open manhole cover (TM 9-2320-279-10).
- (9) Set TLI TANK LEVEL INDICATOR switch (3) to on.
- (10) Soldier A holds float (6) in UP position while Soldier B turns screw (7).
- (11) Soldier C tells Soldier B to stop turning screw (7) when TLI TANK LEVEL INDICATOR gage (4) reads 1/4.
- (12) Soldier A holds floats (6 and 8) in UP position while Soldier B turns screw (9).
- (13) Soldier C tells Soldier B to stop turning screw (9) when TLI TANK LEVEL INDICATOR gage (4) reads 1/2.
- (14) Soldier A holds floats (6, 8, and 10) in UP position while Soldier B turns screw (11).
- (15) Soldier C tells Soldier B to stop turning screw (11) when TLI TANK LEVEL INDICATOR gage (4) reads 3/4.
- (16) Soldier A holds floats (6, 8, 10, and 12) in UP position while Soldier B turns screw (13).
- (17) Soldier C tells Soldier B to stop turning screw (13) when TLI TANK LEVEL INDICATOR gage (4) reads FULL.
- (18) Set TLI TANK LEVEL INDICATOR switch (3) off.
- (19) Install cap (1) on tank level indicator adjuster (2).

d. Follow-on Maintenance.

- (1) Connect batteries (para 7-91).
- (2) Install pump module left side access panel (para 16-48).
- (3) Close pump module rear access doors (TM 9-2320-279-10).

END OF TASK

Electrical System Maintenance Instructions (Cont)

7-88 FUEL LEVEL SENSOR REMOVAL/INSTALLATION (M978).

This task covers:

- a. Removal
- b. Installation

c. Follow-on Maintenance

INITIAL SETUP

Models

M978

Test Equipment

None

Special Tools

None

Supplies

Compound, sealing, pipe thread,
Item 18, Appendix C
Tags, identification, Item 48, Appendix C

Personnel Required

MOS 63S, Heavy wheel vehicle mechanic

References

None

Equipment Condition

| | |
|--------------|---|
| TM or Para | Condition Description |
| Para 7-91 | Batteries disconnected. |
| Para 16-52.1 | Hose cover removed. (some models only) |

Special Environmental Conditions

None

General Safety Instructions

No smoking, open flame, or sparks within 50 ft (15 m) of vehicle. Fire extinguisher nearby.

a. Removal.

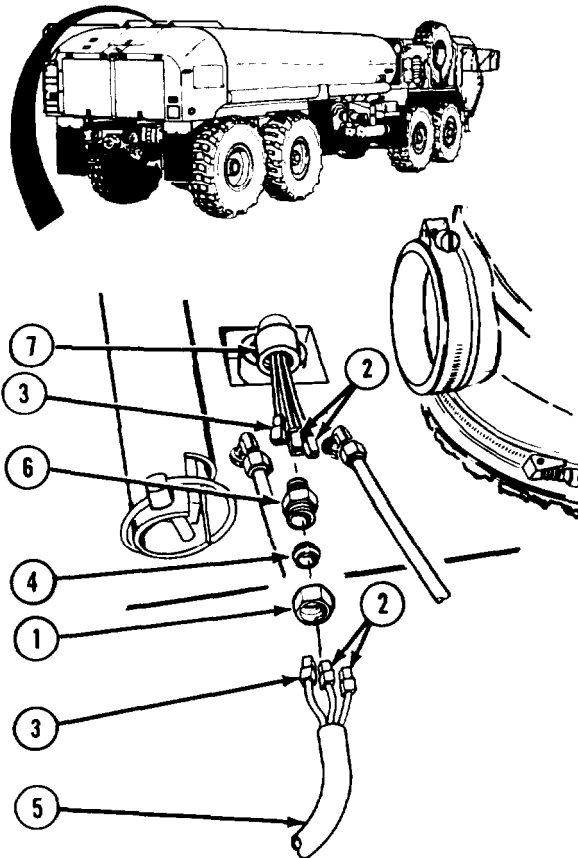
NOTE

- There are two kinds of fuel level sensors. Model A is made from plastic, while Model B is made from brass.
- If fuel level sensor must be replaced and same model is not available, tank level indicator adjuster must also be replaced. Refer to TM 9-2320-279-24P for proper parts identification.

(1) Remove nut (1).

NOTE

- Tag and mark electrical connectors before removal.
 - Model A has three connectors. Model B has two connectors.
- (2) Disconnect two connectors (2) and connector (3).
- (3) Remove bushing (4) and nut (1) from line (5).
- (4) Remove fitting (6) from fuel level sensor (7).



Electrical System Maintenance Instructions (Cont)

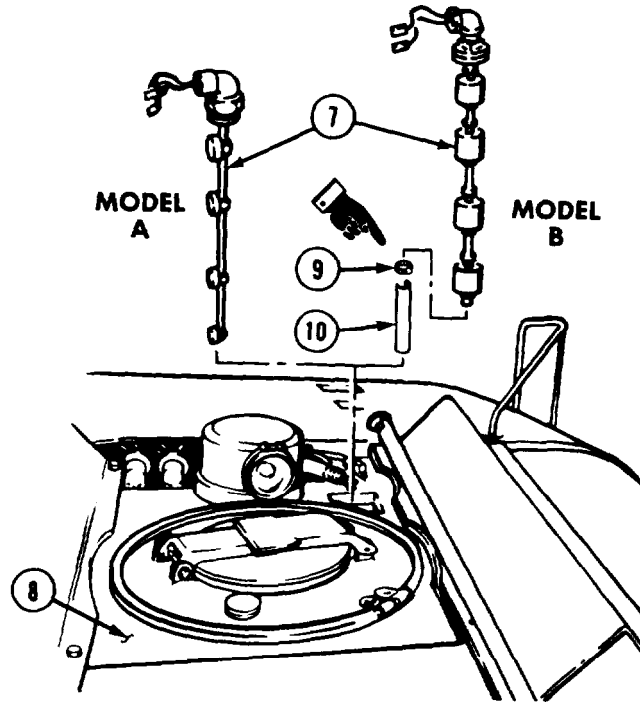
7-88. FUEL LEVEL SENSOR REMOVAL/INSTALLATION (M978) (CONT).

- (5) Remove fuel level sensor (7) from tank (8).

NOTE

Step (6) is for Model B only.

- (6) Remove clamp (9) and ground strap (10) from fuel level sensor (7).



b. Installation

NOTE

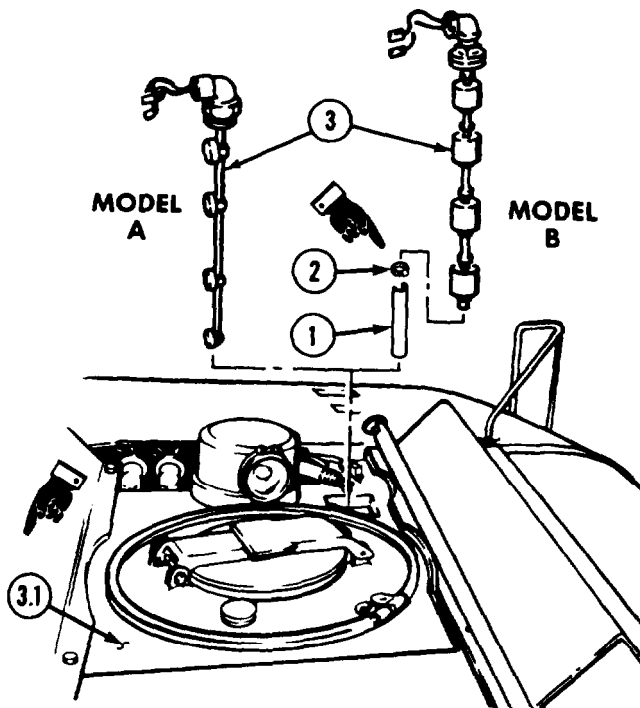
Step (1) is for Model B only.

- (1) Install ground strap (1) and clamp (2) on fuel level sensor (3).

WARNING

Adhesives, solvents, and sealing compounds can burn easily, can give off harmful vapors, and are harmful to skin and clothing. To avoid injury or death, keep away from open fire and use in well-ventilated area. If adhesive, solvent, or sealing compound gets on skin or clothing, wash immediately with soap and water.

- (1.1) Coat threads of fuel level sensor (3) with pipe thread sealing compound and install in tank (3.1).



Electrical System Maintenance Instructions (Cont)

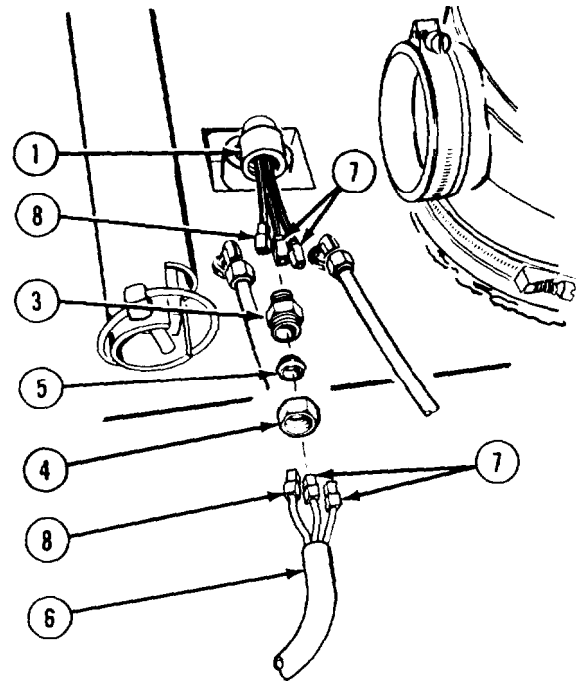
- (2) Coat threads of fitting (3) with pipe thread sealing compound and install fitting in fuel level sensor (1).
- (3) Install nut (4) and bushing (5) on line (6).

NOTE

- Model A has three connectors.
- Model B has two connectors.
- (4) Connect two connectors (7) and connector (8).
- (5) Install nut (4) on fitting (3).

c. Follow-on Maintenance.

- (1) Connect batteries (para 7-91).
- (2) Check fuel level sensor for proper operation and adjust tank level indicator adjuster (para 7-87).
- (3) Install hose cover (some models only) (para 16-52.1).



END OF TASK

| 7-89. ELECTRIC HORN REMOVAL/INSTALLATION. | |
|--|--|
| This task covers: | |
| a. Removal | c. Follow-on Maintenance |
| b. Installation | |
| INITIAL SETUP | |
| Models All | References None |
| Test Equipment None | Equipment Condition TM or Para Condition Description TM 9-2320-279-10 Shut off engine. Para 14-5 Skid plate grille removed. |
| Special Tools None | Special Environmental Conditions None |
| Supplies Tags, identification, Item 48, Appendix C | General Safety Instructions None |
| Personnel Required MOS 63S. Heavy wheel vehicle mechanic | |

Electrical System Maintenance Instructions (Cont)

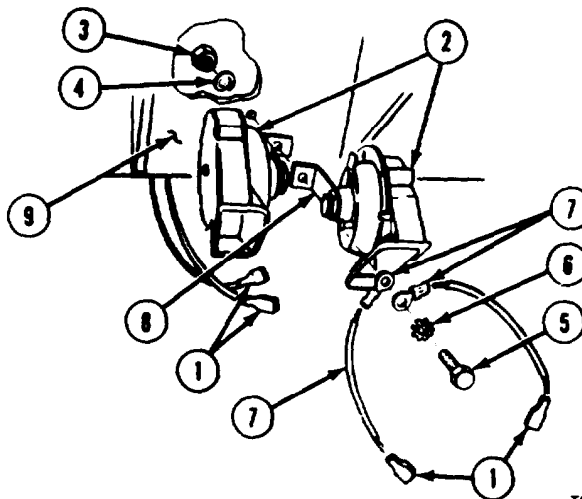
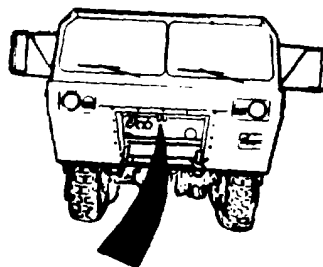
17-89. ELECTRIC HORN REMOVAL/INSTALLATION (CONT).

a. Removal.

NOTE

Tag and mark wires before removal.

- (1) Disconnect four wires (1) from two horns (2).
- (2) Remove nut (3), lockwasher (4) screw (5), lockwasher (6), two wire assemblies (7), two horns (2), and brackets (8) from chassis (9).

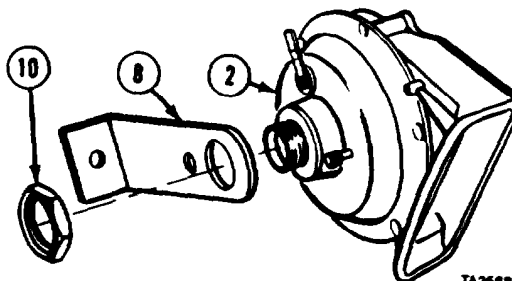


TA356884

NOTE

Right and left brackets are removed in the same way.

- (3) Remove nut (10) and bracket (8) from horn (2).



TA356885

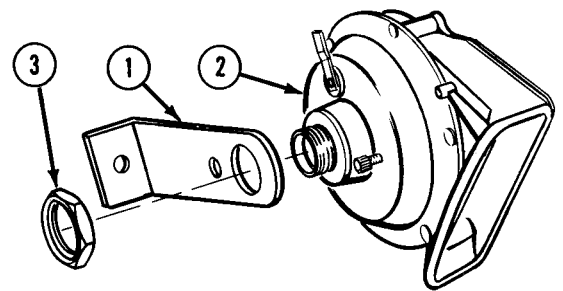
Electrical System Maintenance Instructions (Cont)

b. *Installation.*

NOTE

Right and left brackets are installed in the same way.

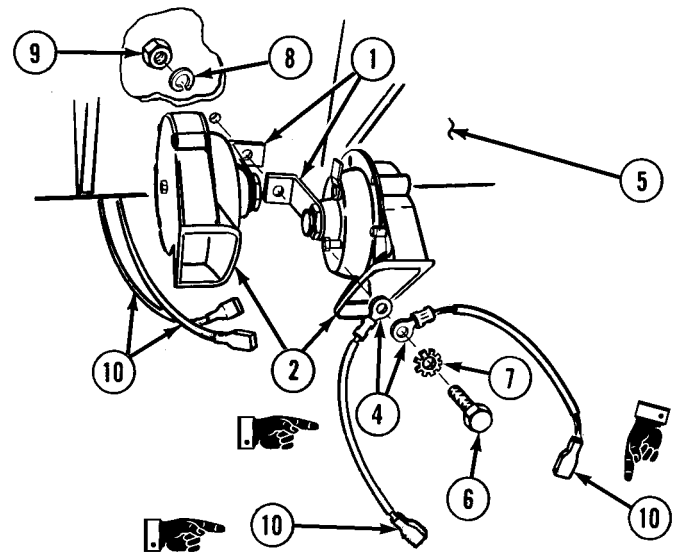
- (1) Install bracket (1) to horn (2) with nut (3).



- (2) Install two wire assemblies (4), two horns (2), and brackets (1) to chassis (5) with screw (6), lockwasher (7), lockwasher (8), and nut (9).
- (3) Install four wires (10) to two horns (2).

c. *Follow-on Maintenance.*

- (1) Install skid plate grille (para 14-5).
- (2) Check operation of horn (TM 9-2320-279-10).



END OF TASK

Electrical System Maintenance Instructions (Cont)

Section X. BATTERIES AND BATTERY BOX

7-90. BATTERIES, TERMINALS, AND CABLES REMOVAL/INSTALLATION,

This task covers:

- a. Removal
- b. Service
- c. Installation
- d. Follow-on Maintenance

INITIAL SETUP

Models

All

Test Equipment

None

Special Tools

None

Supplies

Compound, corrosion preventive,
Item 12.2, Appendix C

Personnel Required

MOS 63S, Heavy wheel vehicle mechanic

References

TM 9-6140-200-14

Equipment Condition

TM or Para Condition Description
TM 9-2320-279-10 Shut off engine.

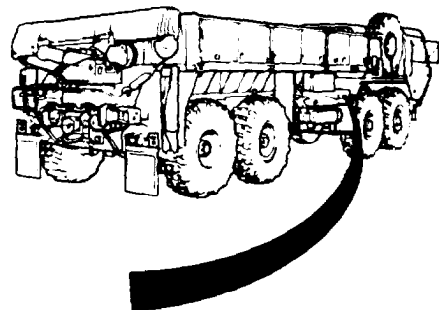
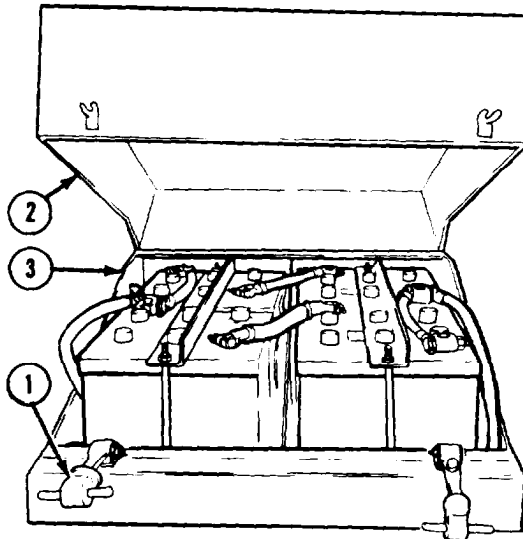
Special Environmental Conditions

None

General Safety Instructions

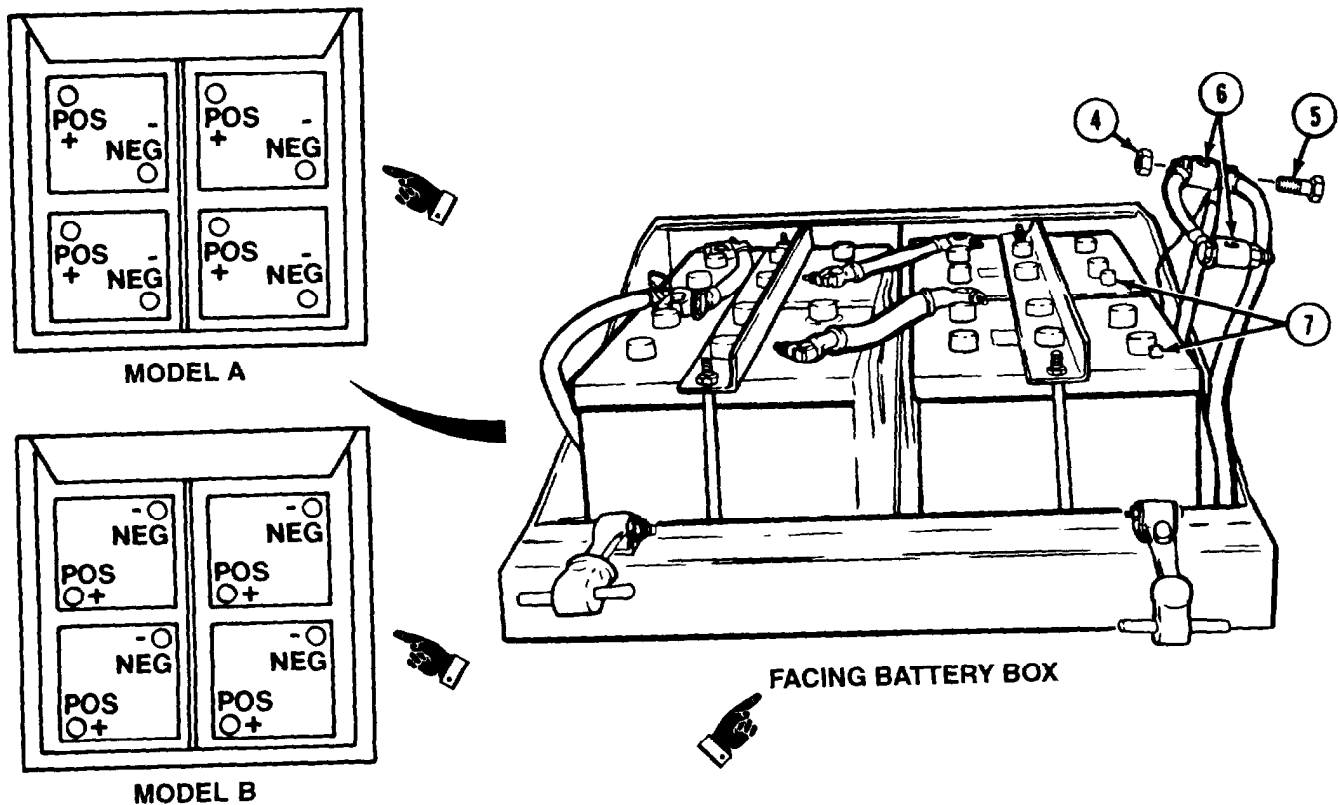
None

a. Removal.



- (1) Release two rubber hood hooks (1).
- (2) Remove battery box cover (2) from battery box (3).

Electrical System Maintenance Instructions (Cont)



WARNING

Batteries produce explosive gases. To prevent injury to personnel, keep sparks and flames away, and do not smoke near batteries.

NOTE

- There are two types of batteries. Model A is identified by a 6TN printed on the side of the battery, while Model B has a 6TL printed on the side of the battery.
- Refer to the illustrations for Models A and B for proper positioning of batteries. The battery caps of Model B do not protrude through the bracket.
- If Model A and B are combined on the same vehicle, all batteries will be positioned as shown for Model B.

- (3) Remove two nuts (4) and screws (5).

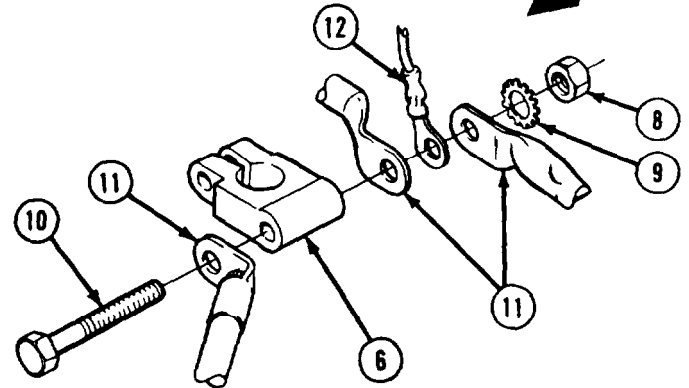
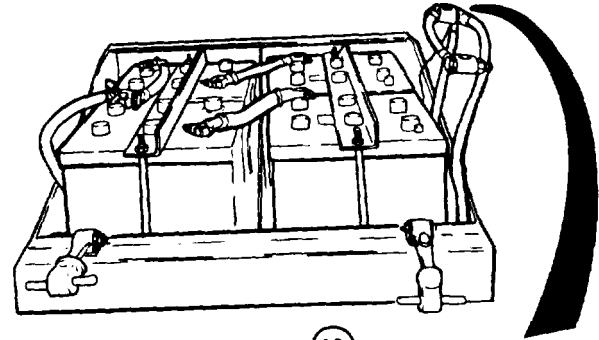
CAUTION

Do not pry between terminals and top of battery. Prying can cause damage to battery.

- (4) Disconnect two negative terminals (6) from battery posts (7).

Electrical System Maintenance Instructions (Cont)

- (5) Remove two nuts (8), lockwashers (9), and screws (10).
- (6) Remove three negative battery cables (11) and STE/ICE wire (12) from terminals (6).



Electrical System Maintenance Instructions (Cont)

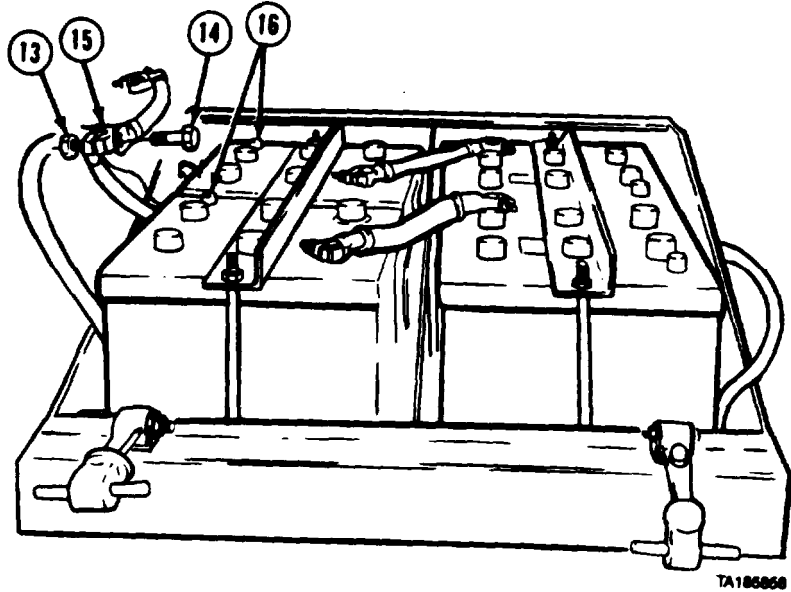
7-90. BATTERIES, TERMINALS, AND CABLES REMOVAL/INSTALLATION (CONT).

- (7) Remove two nuts (13) and screws (14).

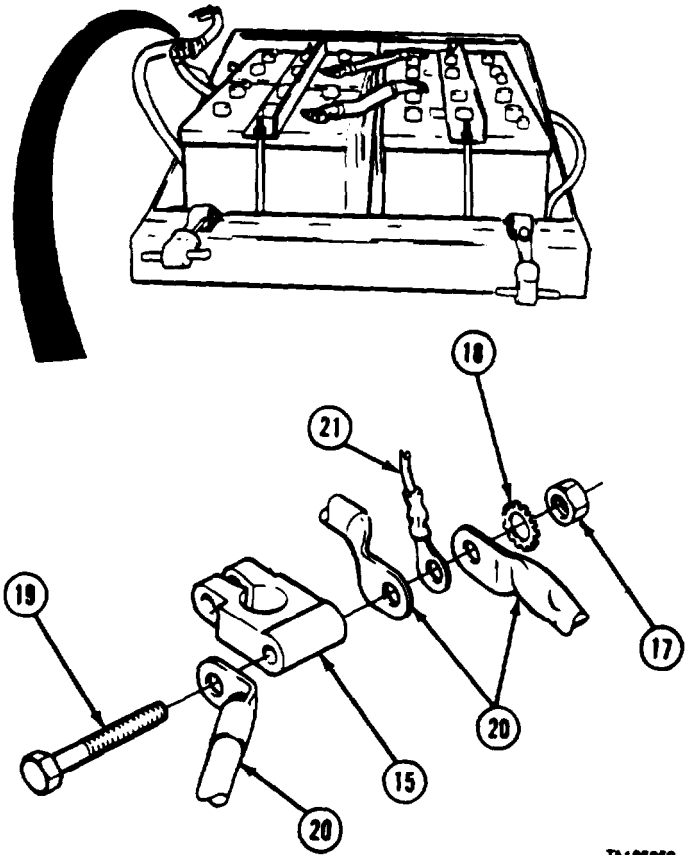
CAUTION

Do not pry between terminals and top of battery. Prying can cause damage to battery.

- (8) Disconnect two positive terminals- (15) from battery posts (16).

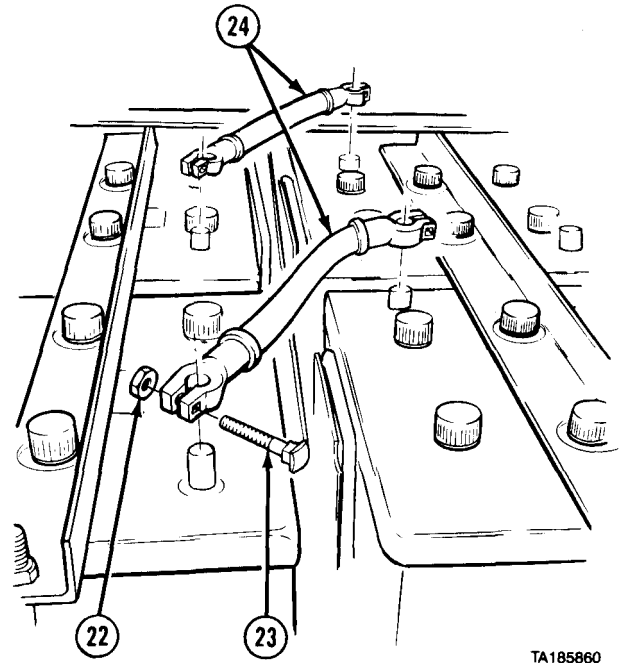


- (9) Remove two nuts (17), lockwashers (18), and screws (19).
- (10) Remove three positive battery cables (20) and STE/ICE wire (2 1) from terminals (15).



Electrical System Maintenance Instructions (Cont)

- (11) Remove four nuts (22), screws (23), and jumper cable assemblies (24).



TA185860

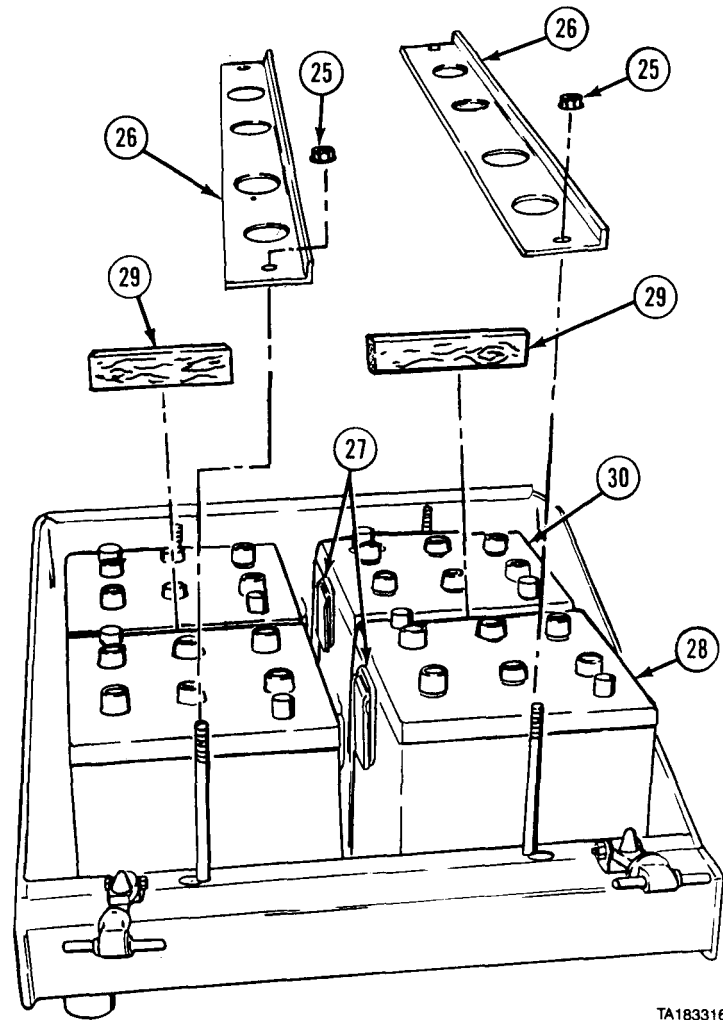


Electrical System Maintenance Instructions (Cont)

7-90. BATTERIES, TERMINALS, AND CABLES REMOVAL/INSTALLATION (CONT).

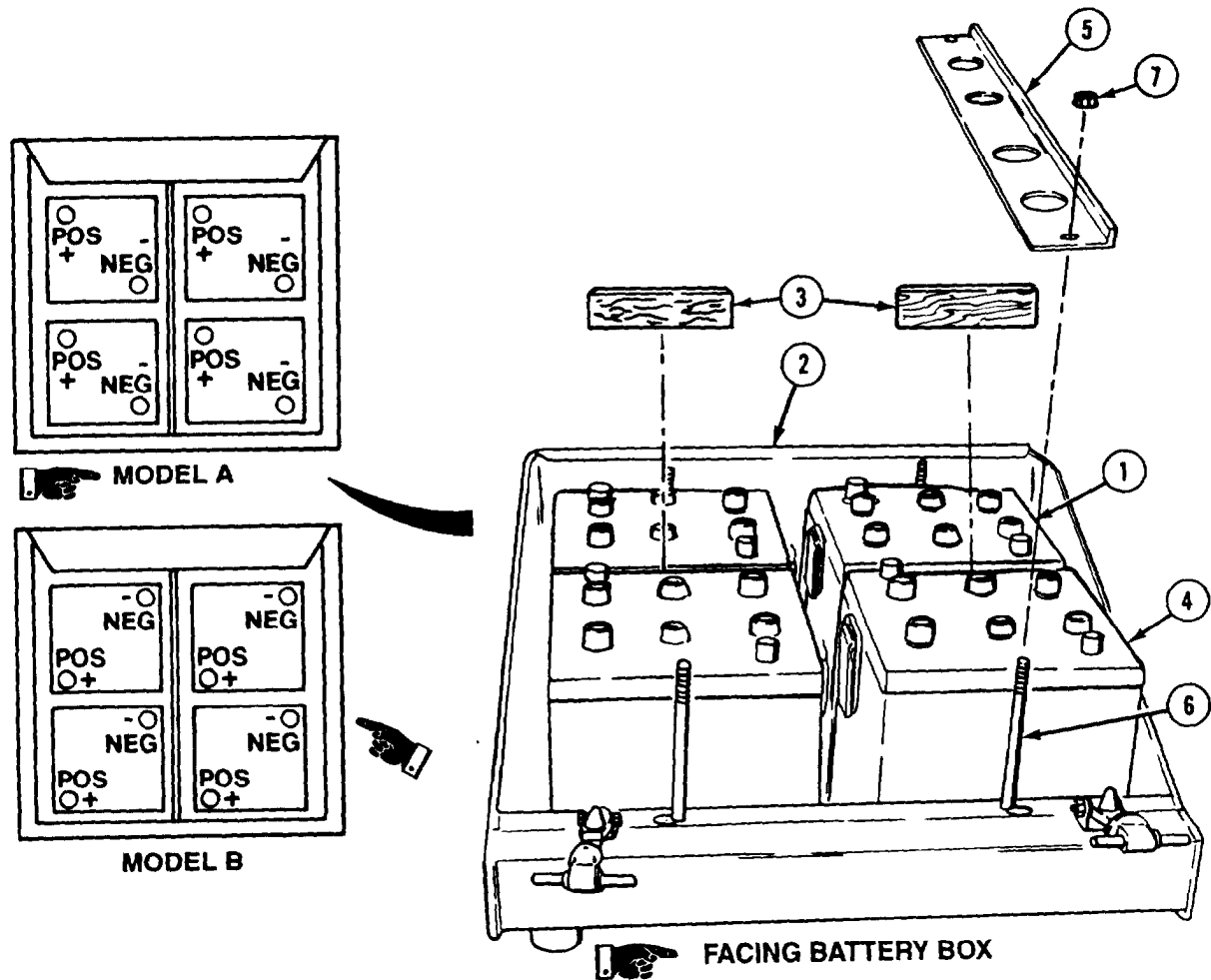
- (12) Remove four nuts (25) and two brackets (26).
- (13) Using handles (27), lift out two front batteries (28).
- (14) Remove two wooden spacers (29).
- (15) Using handles (27), lift out two back batteries (30).

b. Service. Service battery (TM 9-6140-200-14).



TA183316

Electrical System Maintenance Instructions (Cont)



c. Installation.

NOTE

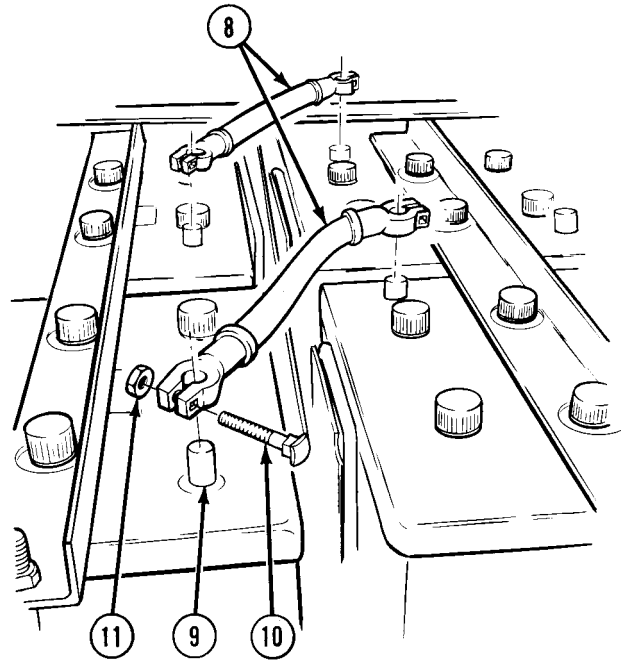
- When installing Model B batteries into Model A battery box, locating tabs, in bottom of battery box, should be bent outward to make more room for batteries.
- There are two types of batteries. Model A is identified by a 6TN printed on the side of the battery, while Model B has a 6TL printed on the side of the battery.
- Refer to the illustrations for Models A and B for proper positioning of batteries. The battery caps of Model B do not protrude through the bracket.
- If Models A and B are combined on the same vehicle, all batteries will be positioned as shown for Model B.

- (1) Install two back batteries (1) in battery box (2).
- (2) Install two wooden spacers (3).
- (3) Install two front batteries (4) in battery box (2).
- (4) Install two brackets (5) over carriage bolts (6) with four nuts (7).

Electrical System Maintenance Instructions (Cont)

7-90. BATTERIES, TERMINALS, AND CABLES REMOVAL/INSTALLATION (CONT).

- (5) Install two jumper cable assemblies (8) on four battery posts (9) with four screws (10) and nuts (11). Tighten nuts (11) to 84 to 96 lb-in (9-11 NSm).

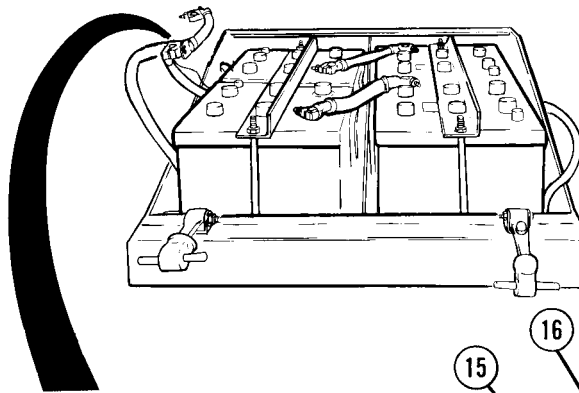


CAUTION

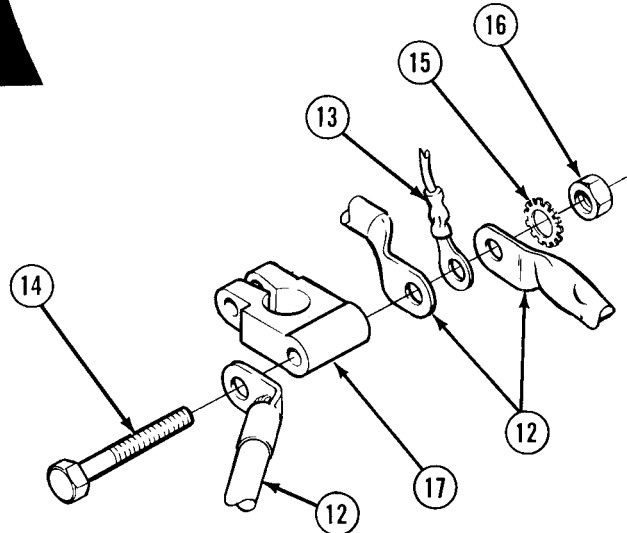
While tightening nuts, hold screws with wrench or damage to battery may occur.

NOTE

STE/ICE wire connects to front battery terminal. There is only one cable connected to rear terminal.

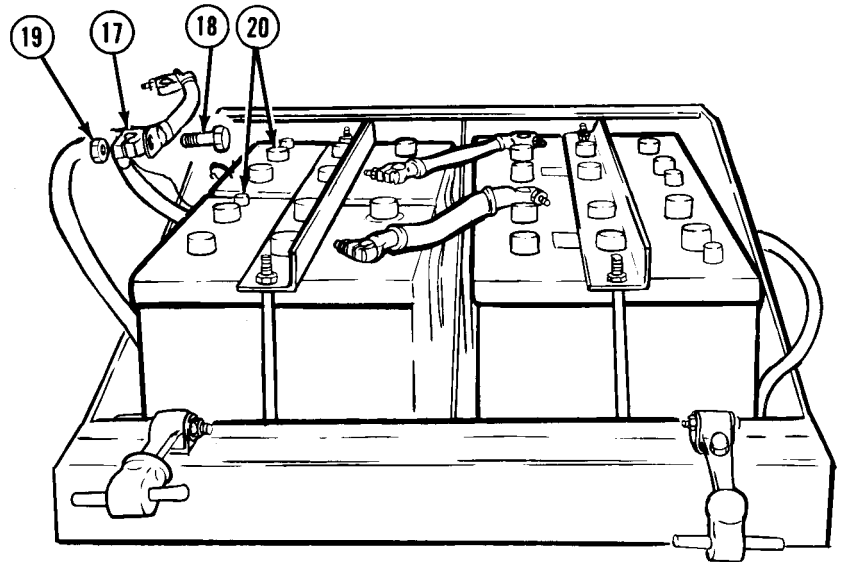


- (6) Install three positive battery cables (12) and STE/ICE wire (13) with two screws (14), lockwashers (15), and nuts (16) on terminals (17). Tighten nuts (16) to 12 to 16 lb-ft. (16-22 NSm).



Electrical System Maintenance Instructions (Cont)

- (7) Install two positive terminals (17) with two screws (18) and nuts (19) on battery posts (20). Tighten nuts (19) to 84 to 96 lb-in (9-11 NSm).

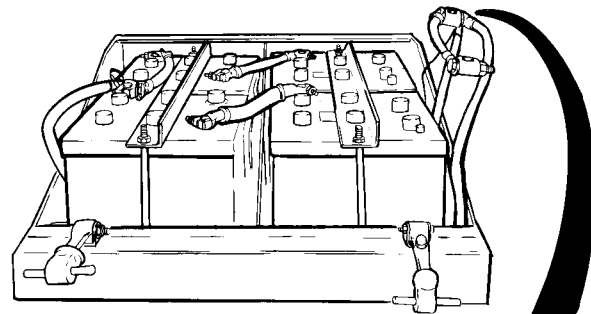


CAUTION

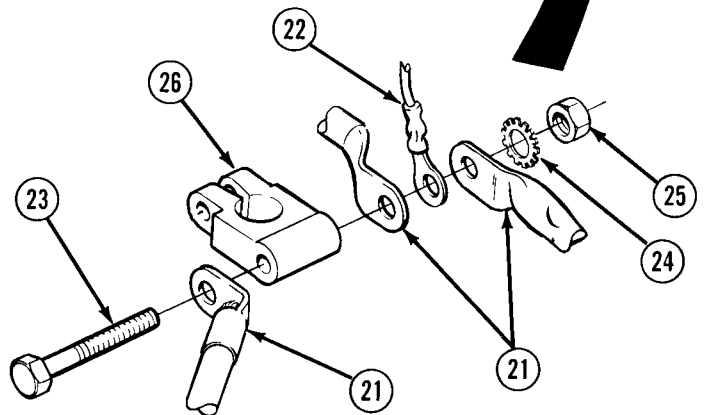
While tightening to nuts, hold screws with wrench or damage may occur.

NOTE

STE/ICE wire connects to front battery terminal. There is only one cable connected to rear terminal.



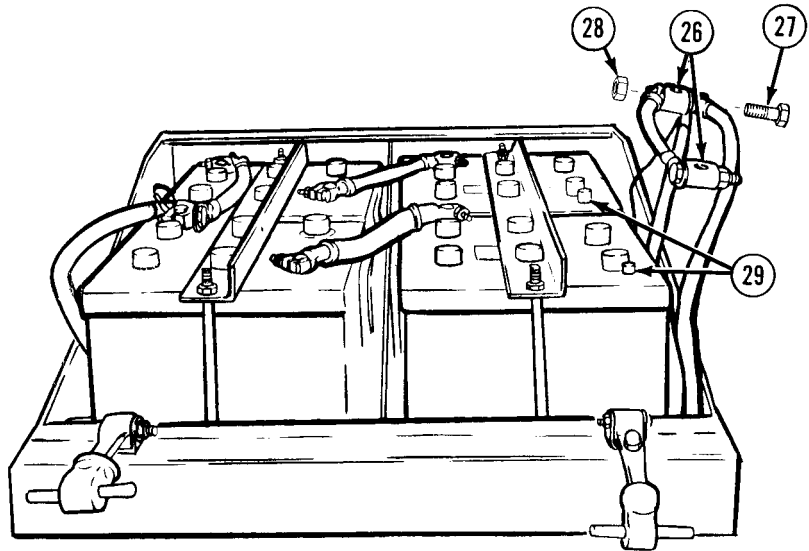
- (8) Install three negative battery cables (21) and STE/ICE wire (22) with two screws (23), lockwashers (24), and nuts (25) on terminals (26). Tighten nuts (25) to 12 to 16 lb-ft. (16-22 NSm).



Electrical System Maintenance Instructions (Cont)

7-90. BATTERIES, TERMINALS, AND CABLES REMOVAL/INSTALLATION (CONT).

- (9) Install two negative terminals (26) with two screws (27) and nuts (28) on battery posts (29). Tighten nuts to 84 to 96 lb-in (9-11 NSm).

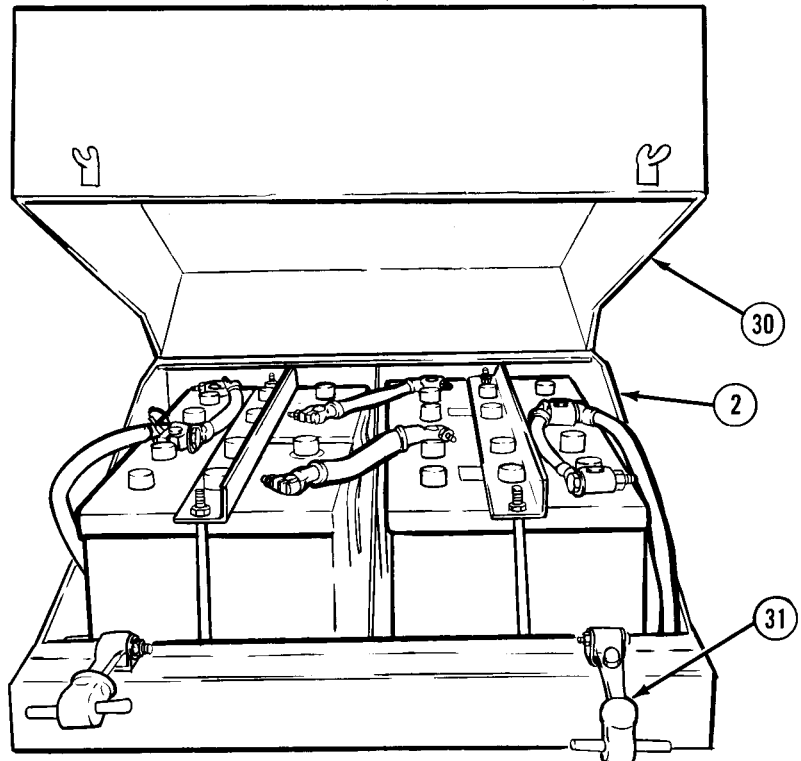


- (10) Install battery box cover (30) on battery box (2) with rubber hood hooks (31).

d. Follow-on Maintenance.

- (1) Start engine to check operation of batteries (TM 9-2320-279-10).
- (2) Shut off engine (TM 9-2320-279-10).

END OF TASK



Electrical System Maintenance Instructions (Cont)

7-91. NEGATIVE BATTERY CABLES DISCONNECT/CONNECT.

This task covers:

- a. Disconnect
- b. Connect
- c. Follow-on Maintenance

INITIAL SETUP

Models

All

Test Equipment

None

Special Tools

None

Supplies

Compound, corrosion preventive, Item 12.2, Appendix C

Personnel Required

MOS 63S, Heavy wheel vehicle mechanic

References

None

Equipment Condition

TM or Para Condition Description
 TM 9-2320-279-10 Shut off engine.

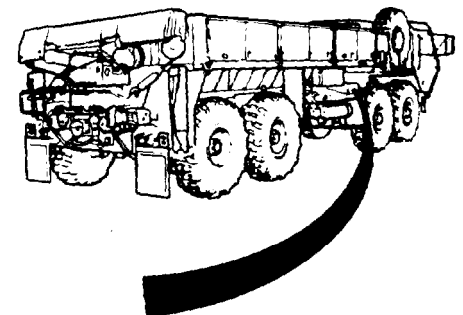
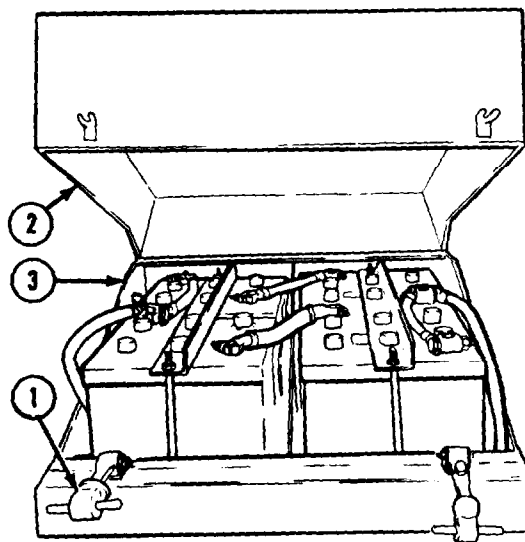
Special Environmental Conditions

None

General Safety Instructions

None

a. Disconnect.



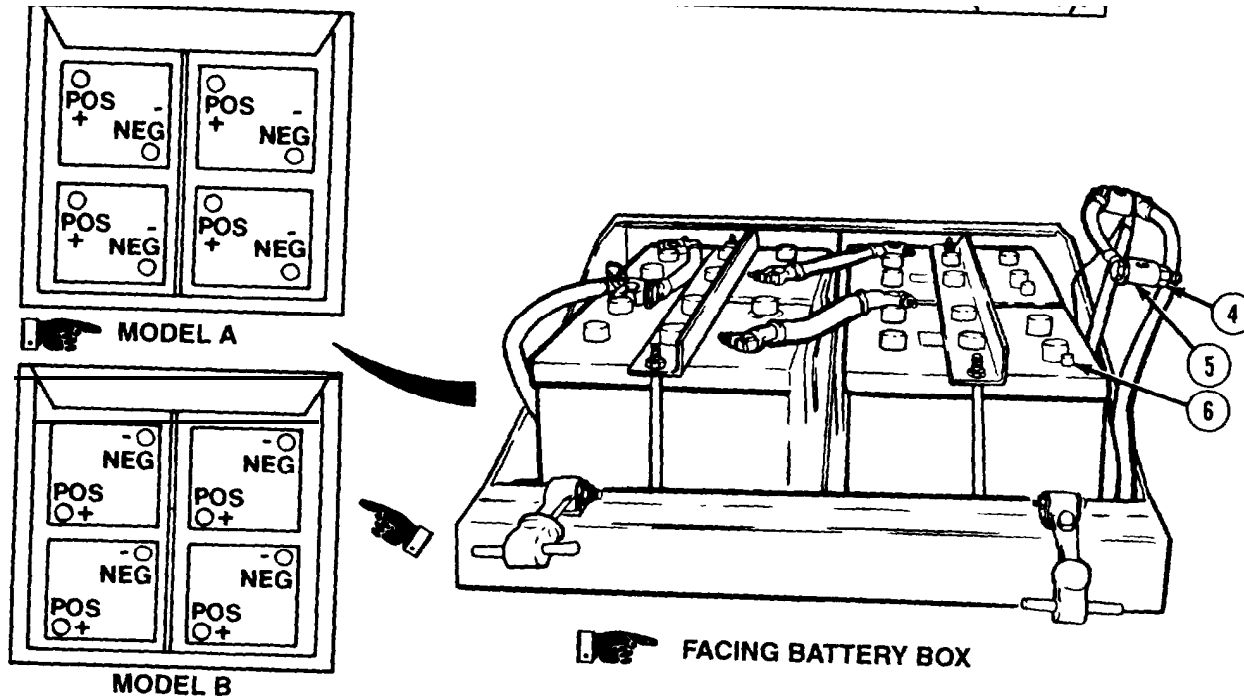
WARNING

Batteries produce explosive gases. To prevent injury to personnel, keep sparks and flames away and do not smoke.

- (1) Release two rubber hood hooks (1).
- (2) Remove battery box cover (2) from battery box (3).

Electrical System Maintenance Instructions (Cont)

7-91. NEGATIVE BATTERY CABLES DISCONNECT/CONNECT (CONT).



NOTE

- There are two types of batteries. Model A is identified by a 6TN printed on the side of the battery, while Model B has a 6TL printed on the side of the battery.
- Refer to the illustrations for Models A and B for proper positioning of batteries. The battery caps of Model B do not protrude through the bracket.
- If Models A and B are combined on the same vehicle, all batteries will be positioned as shown for Model B.

(3) Loosen two nuts (4).

(4) Disconnect two negative cable terminals (5) from battery posts (6).

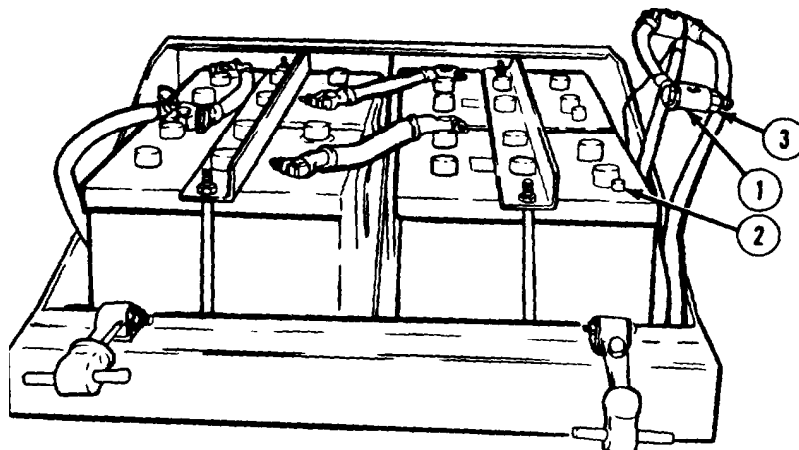
b. Connect.

WARNING

Batteries produce explosive gases. To prevent injury to personnel, keep sparks and flames away, and do not smoke.

(1) Connect two negative cable terminals (1) to battery posts (2).

(2) Tighten two nuts (3).



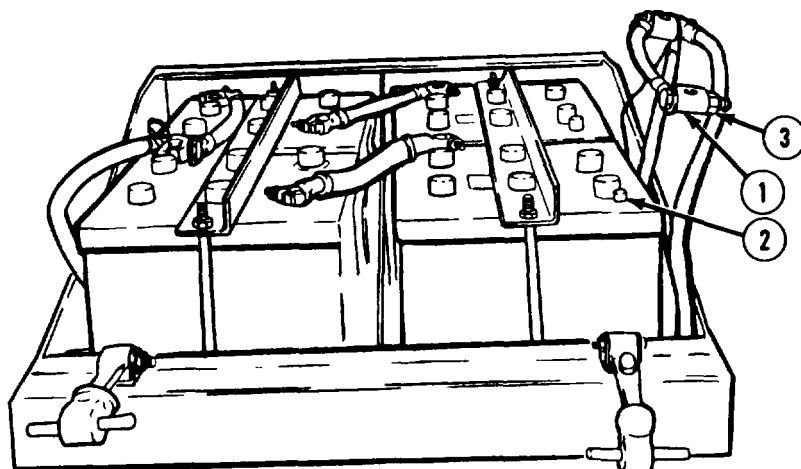
Electrical System Maintenance Instructions (Cont)

b. Connect.

WARNING

Batteries produce explosive gases. To prevent injury to personnel, keep sparks and flames away, and do not smoke.

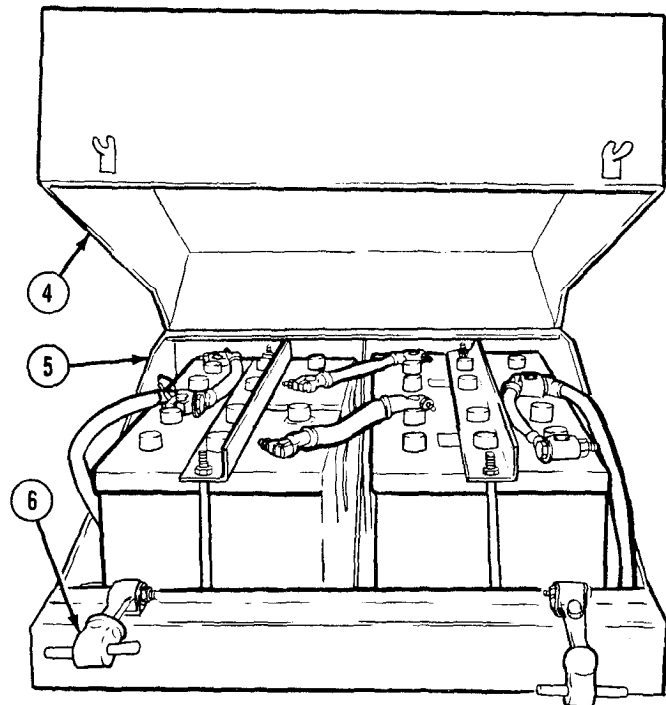
- (1) Connect two negative cable terminals (1) to battery posts (2).
- (2) Tighten two nuts (3).
- (2.1) Apply corrosion preventive compound to negative battery terminals and cable connections.



Electrical System Maintenance Instructions (Cont)

- (3) Install battery box cover (4) on battery box (5) with rubber hood hooks (6).
- c. *Follow-on Maintenance.*
 - (1) Start engine to check operation of batteries (TM 9-2320-279-10).
 - (2) Shut off engine (TM 9-2320-279-10).

END OF TASK



TA185494

| | | |
|---|---|--|
| 7-92. BATTERY BOX AND NATO CONNECTOR REMOVAL/REPAIR/INSTALLATION. | | |
| This task covers: | | |
| a. Removal | d. Installation | |
| b. Disassembly | e. Follow-on Maintenance | |
| c. Assembly | | |
| INITIAL SETUP | | |
| <i>Models</i> | <i>Equipment Condition</i> | |
| All (Includes arctic kit battery box) | <i>TM or Para</i> | <i>Condition Description</i> |
| <i>Test Equipment</i> | TM 9-2320-279-10 | Air system drained. |
| None | TM 9-2320-279-10 | Fire extinguisher removed (M978 only). |
| <i>Special Tools</i> | Para 7-90 | Batteries removed. |
| None | Para 11-29 | No. 1 Air reservoir removed. |
| <i>Supplies</i> | Para 11-31 | No. 3 Air reservoir removed. |
| Tags, identification, Item 48, Appendix C | | |
| Adhesive, Item 3.4, Appendix C | | |
| <i>Personnel Required</i> | <i>Special Environmental Conditions</i> | |
| MOS 63S, Wheel vehicle mechanic (2) | None | |
| <i>References</i> | <i>General Safety Instructions</i> | |
| None | None | |

Electrical System Maintenance Instructions (Cont)

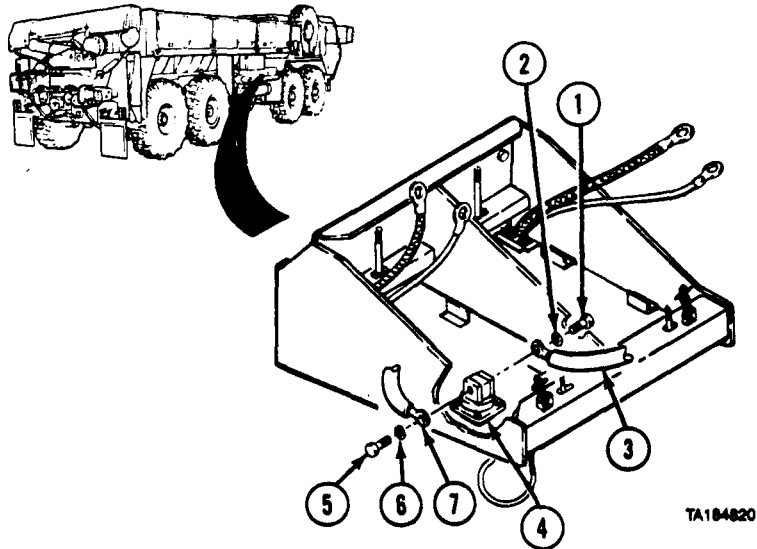
7-92. BATTERY BOX AND NATO CONNECTOR REMOVAL/REPAIR/INSTALLATION (CONT).

a. Removal.

NOTE

Tag and mark battery cables before removal.

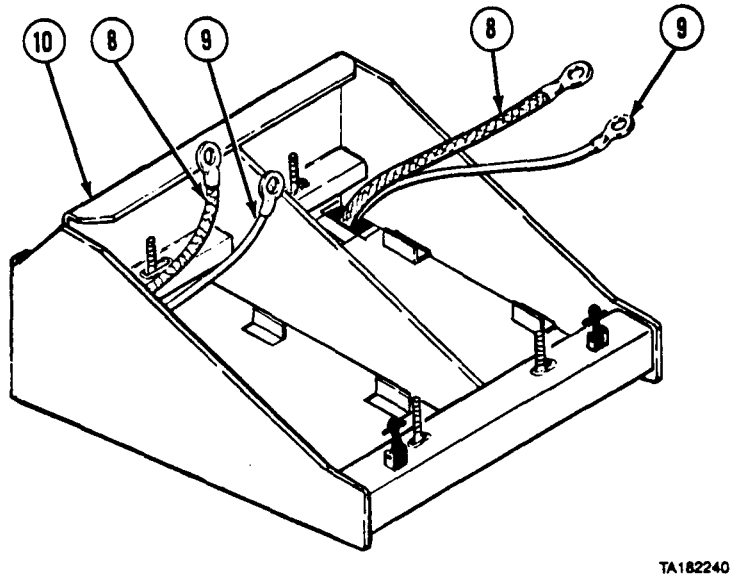
- (1) Remove screw (1), lockwasher (2), and battery cable (3) from NATO connector (4).
- (2) Remove screw (5), lockwasher (6), and battery cable (7) from NATO connector (4).



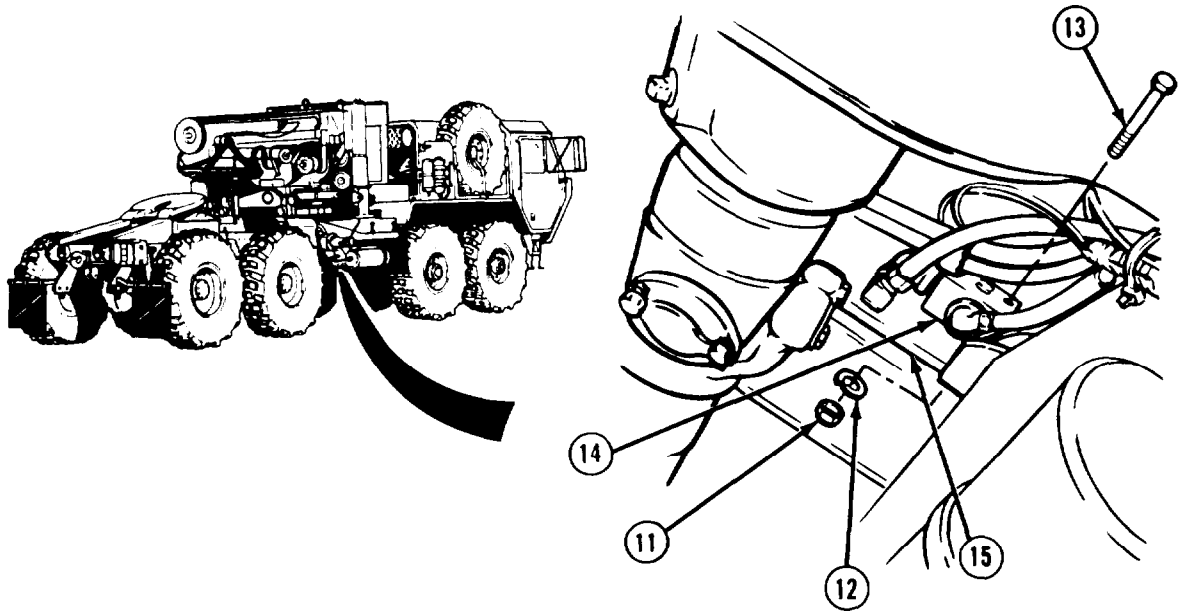
NOTE

Tag and mark STE/ICE wires before removing.

- (3) Push battery cables (8) and STE/ICE wires (9) out through holes in battery box (10).



Electrical System Maintenance Instructions (Cont)



NOTE

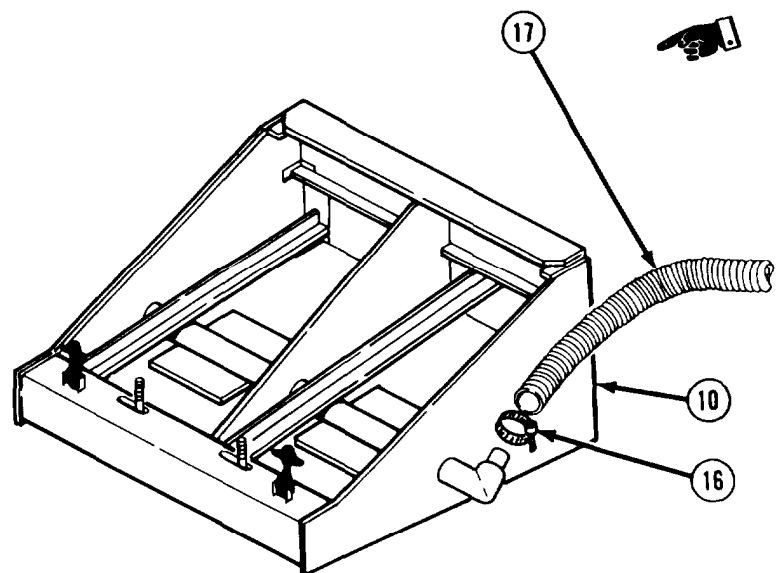
Do step (4) for M983 only.

- (4) Remove two nuts (11), lockwashers (12), and screws (13) from air manifold (14) and frame crossmember (15) under vehicle behind rear of battery box.

NOTE

Do step (5) for arctic kit battery box only.

- (5) Loosen clamp (16) and remove exhaust pipe (17) from battery box (10).



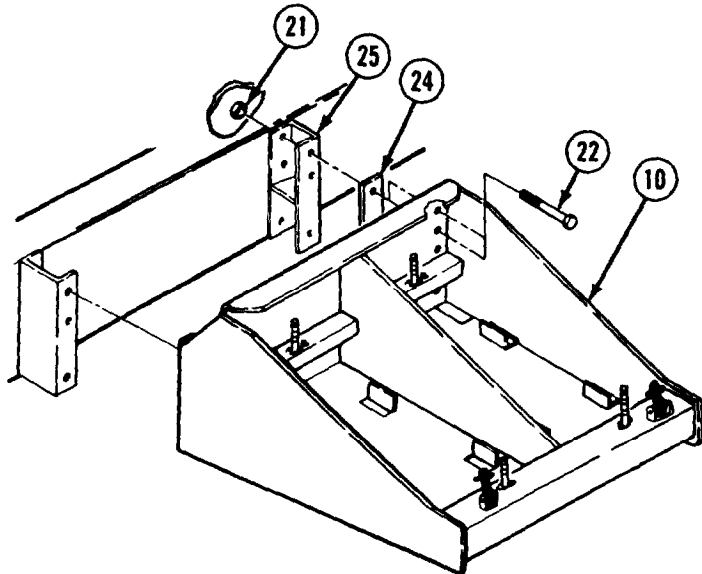
Electrical System Maintenance Instructions (Cont)

7-92. BATTERY BOX AND NATO CONNECTOR REMOVAL/REPAIR/INSTALLATION (CONT).

NOTE

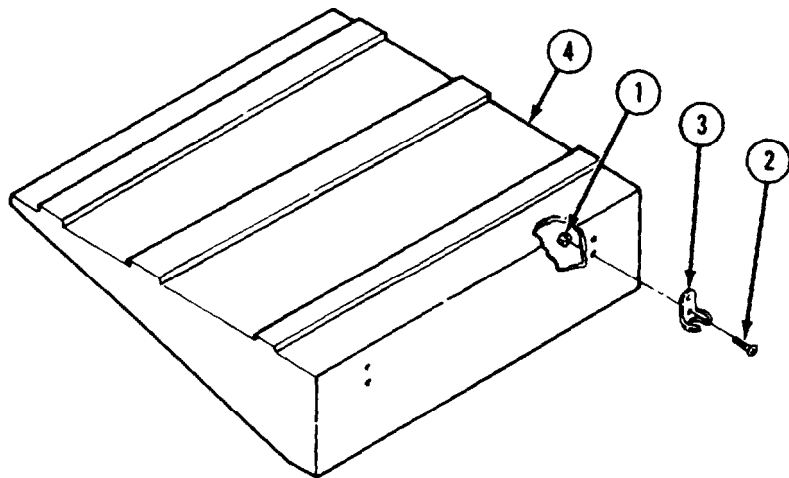
- Support battery box before doing steps (6) thru (7). M1977-CBT only has eight holes thru battery box.
- Bracket spacers on frame are only used on M984. All other models use flat spacers. On M983 there are six spacers used.
- Do steps (6.1) and (6.2) for M1977-CBT only.

- (6) Soldier A removes six nuts (21), while Soldier B holds screws (22) in back of battery box (10).
- (6.1) Soldier A removes four nuts (21), while Soldier B holds screws (22) in back of battery box (10).
- (6.2) Remove four screws (22) and flat spacers (24).
- (7) Remove six screws (22) and flat spacers (24) or bracket spacers (25).



b. Disassembly.

- (1) Remove four locknuts (1), screws (2), and two hood brackets (3) from cover (4).

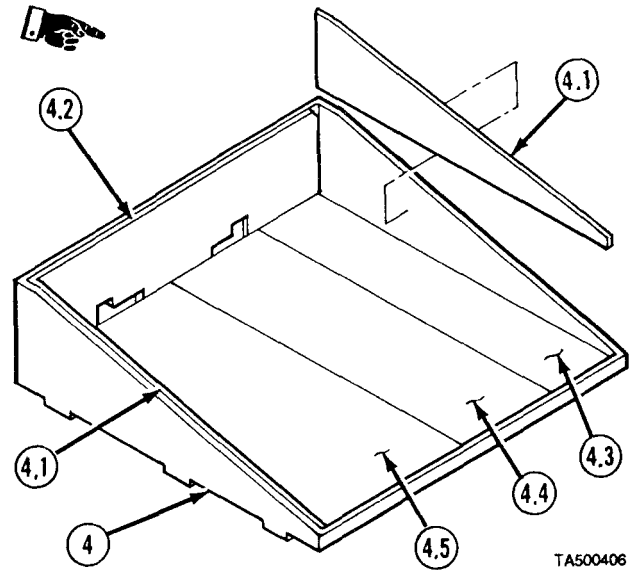


Electrical System Maintenance Instructions (Cont)

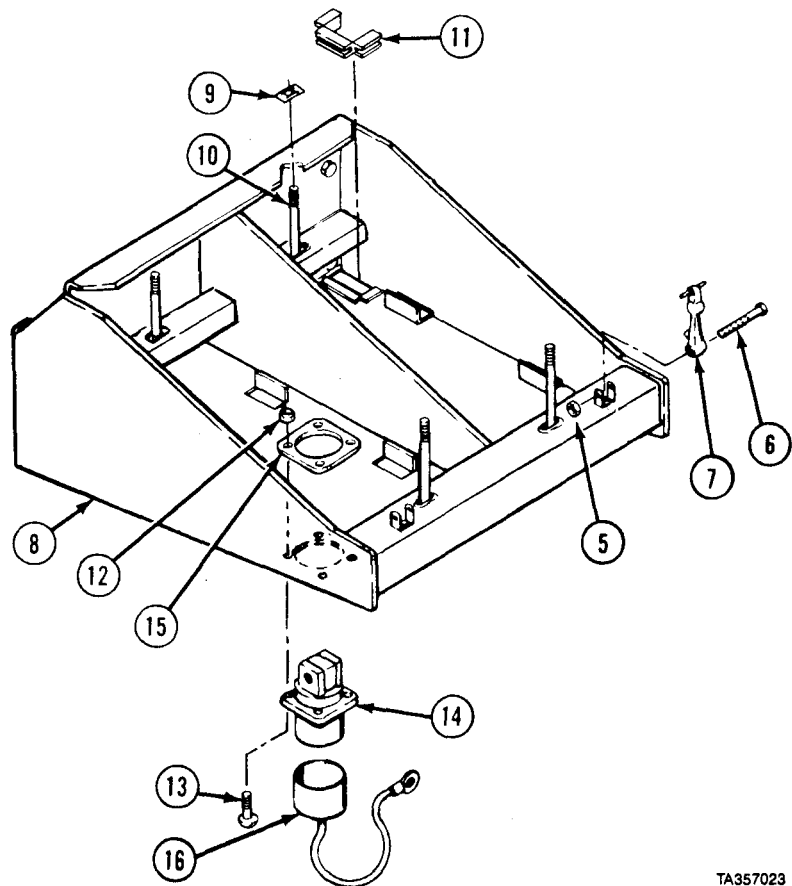
NOTE

Do step (1.1) for arctic kit battery box cover only.

(1.1) If damaged, remove six pieces of insulation (4.1 thru 4.5) from cover(4).

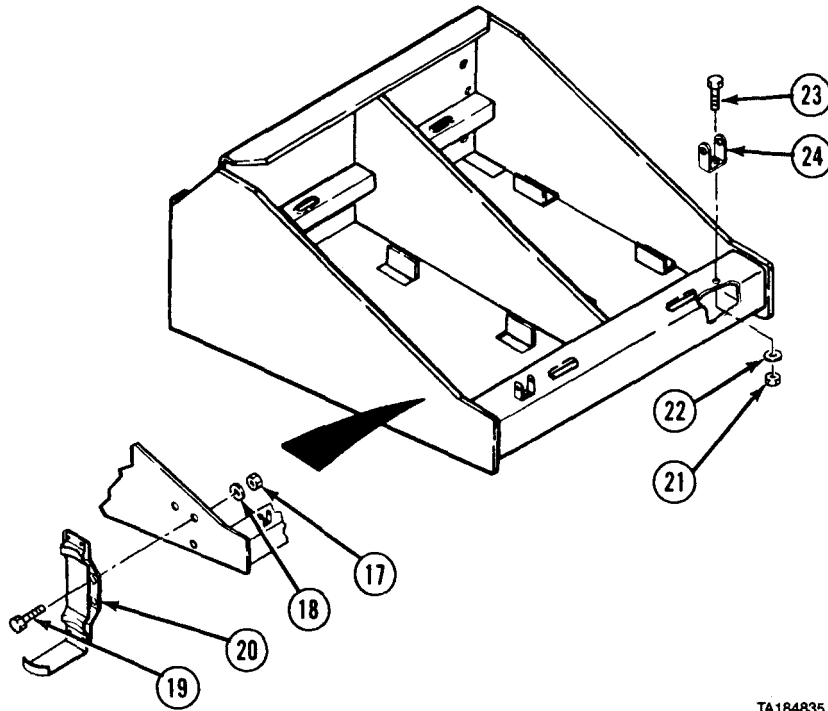


- (2) Remove two locknuts (5), screws (6), and rubber hood hooks (7) from battery box (8).
- (3) Remove two clips (9) from rear bolts (10). Tilt and remove four bolts.
- (4) Remove two quickedge mouldings (11).
- (5) Remove four locknuts (12), screws (13), and NATO connector (14).
- (6) Remove top plate (15) and connector cover (16).



Electrical System Maintenance Instructions (Cont)

7-92. BATTERY BOX AND NATO CONNECTOR REMOVAL/REPAIR/INSTALLATION (CONT).



TA184835

NOTE

Do step (7) for M978 only.

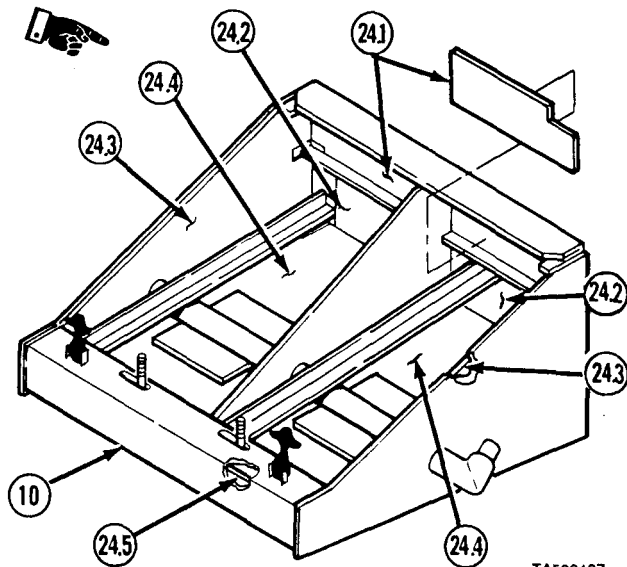
(7) Remove three nuts (17), lockwashers (18), and screws (19). Remove fire extinguisher bracket (20).

(8) Remove two nuts (21), lockwashers (22), screws (23), and hook brackets (24).

NOTE

Do step (9) for arctic kit battery box only.

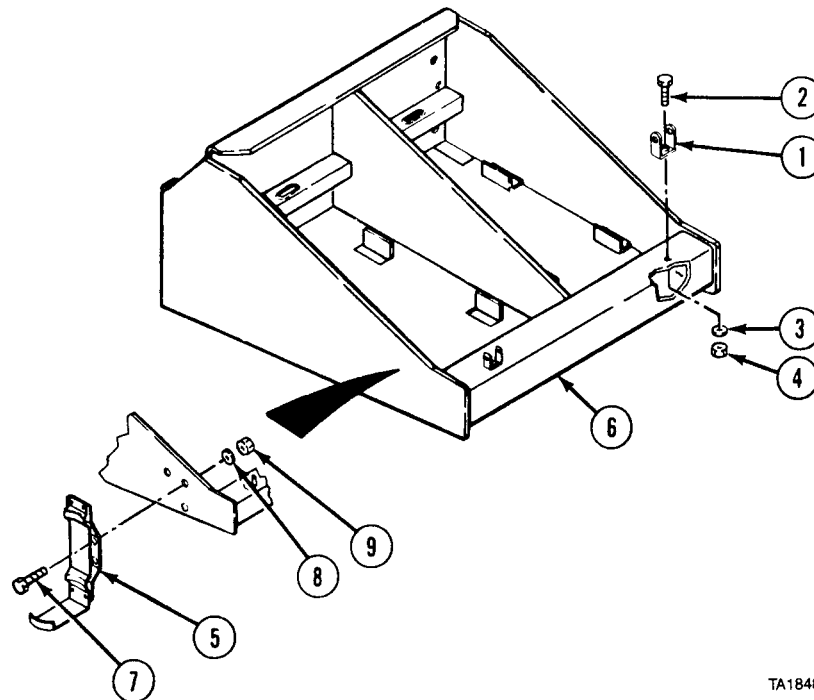
(9) If damaged, remove nine pieces of insulation (24.1 thru 24.5) from battery box (10).



TA500407

Electrical System Maintenance Instructions (Cont)

c. Assembly.



TA184810

(1) Install two hook brackets (1) with screws (2), lockwashers (3), and nuts (4).

NOTE

Do step (2) for M978 only.

(2) Install fire extinguisher bracket (5) on battery box (6) with three screws (7), lockwashers (8), and nuts (9).

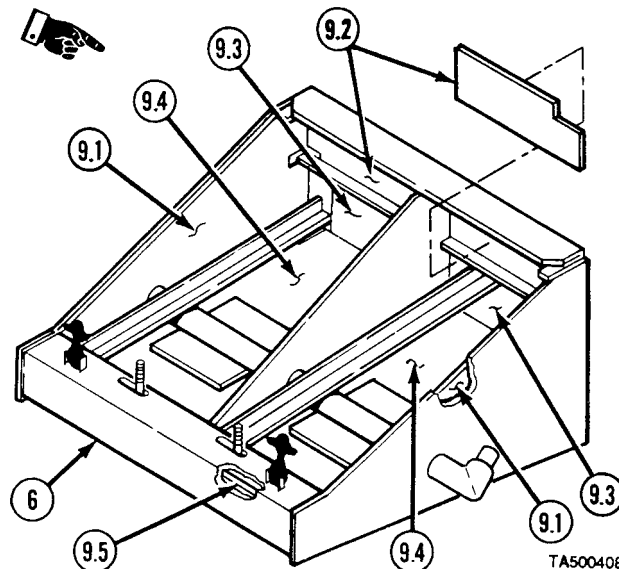
WARNING

Adhesives, solvents, and sealing compounds can burn easily, can give off harmful vapors, and are harmful to skin and clothing. To avoid injury or death, keep away from open fire and use in well-ventilated area. If adhesive, solvent, or sealing compound gets on skin or clothing, wash immediately with soap and water.

NOTE

- Do steps (2.1) and (2.2) for arctic kit battery box only.
- Do step (2.1) for M978 only.

- (2.1) If installing new insulation (9.1), cut clearance holes in insulation to allow for fire extinguisher bracket mounting hardware.
- (2.2) If removed, apply adhesive to nine pieces of insulation (9.1 thru 9.5) and install in battery box (6).

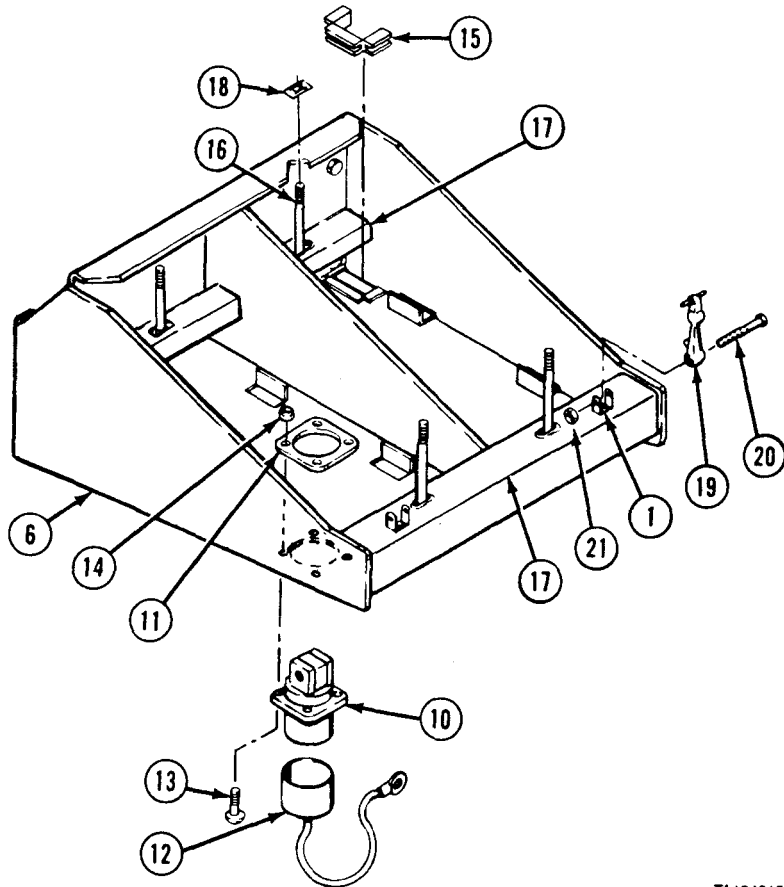


TA500408

Electrical System Maintenance Instructions (Cont)

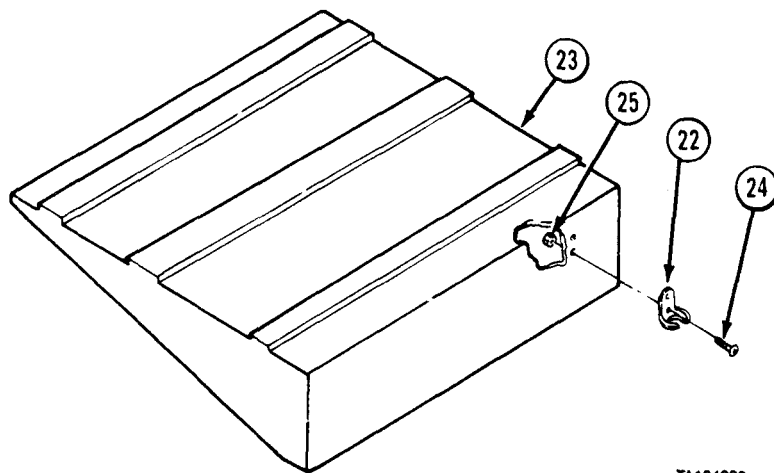
7-92. BATTERY BOX AND NATO CONNECTOR REMOVAL/REPAIR/INSTALLATION (CONT)

- (3) Install NATO connector (10), top plate (11), and connector cover (12) on battery box (6) with four screws (13) and locknuts (14).
- (4) Install two quickedge moldings (15).
- (5) Install four bolts (16) through holes in flange (17).
- (6) Install two clips (18) over two rear bolts (16).
- (7) Install two rubber hood hooks (19) through hook brackets (1) with two screws (20) and locknuts (21).



TA184815

- (8) Install two hood brackets (22) on battery box cover (23) with four screws (24) and locknuts (25).



TA184809

Electrical System Maintenance Instructions (Cont)

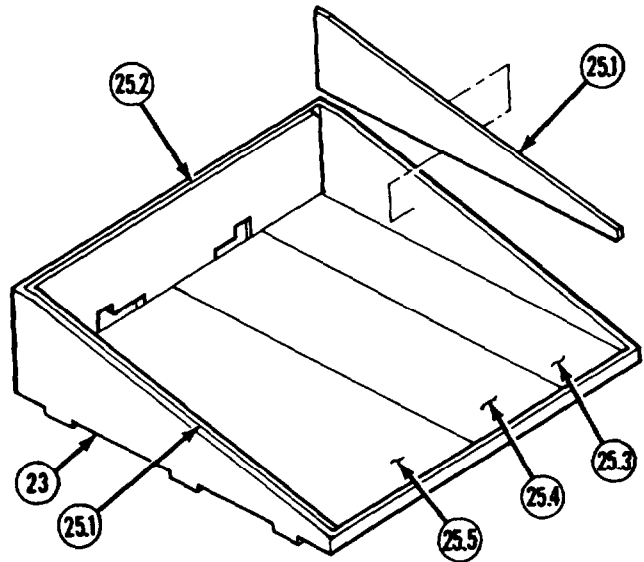
WARNING

Adhesives, solvents, and sealing compounds can burn easily, can give off harmful vapors, and are harmful to skin and clothing. To avoid injury or death, keep away from open fire and use in well-ventilated area. If adhesive, solvent, or sealing compound gets on skin or clothing, wash immediately with soap and water.

NOTE

Do step (9) for arctic kit battery box cover only.

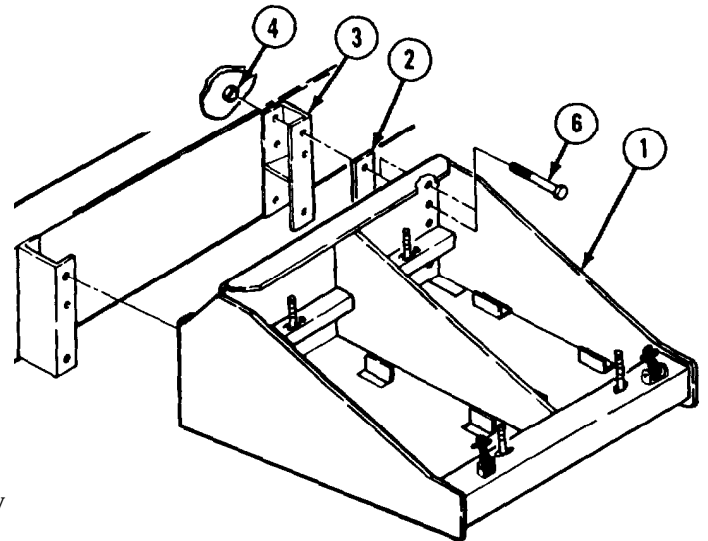
- (9) If removed, apply adhesive to six pieces of insulation (25.1 thru 25.5) and install in battery box cover (23).



d. Installation.

NOTE

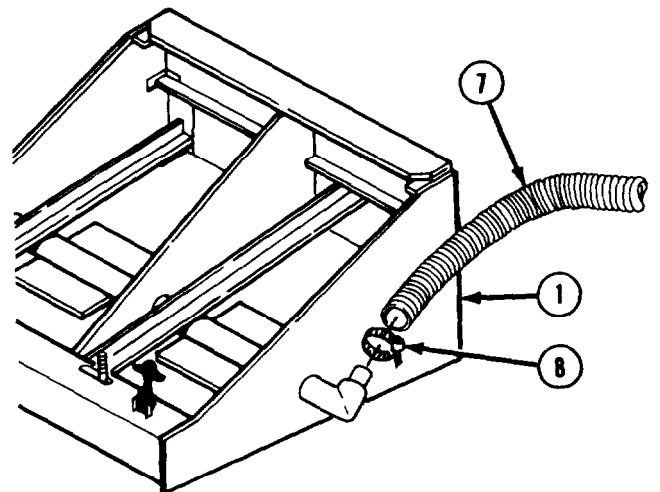
- Support battery box while doing steps (1), (2), and (2.1).
 - Bracket spacers on frame are only used on M984. All other models use flat spacers. On M983 there are six spacers used.
 - Do step (2.1) for M1977-CBT only.
 - M1977-CBT has eight holes on back wall of battery box. Only four holes will be used for mounting. All other models use six screws.
- (1) Soldier A and Soldier B position battery box (1) and flat spacers (2) or two bracket spacers (3) against frame.
 - (2) Soldier A installs six nuts (4) while Soldier B installs six screws (6) in back of battery box through flat spacers (2) or bracket spacers (3).
 - (2.1) Soldier A installs four nuts (4) while Soldier B installs four screws (6) in upper back of battery box through flat spacers (2).



NOTE

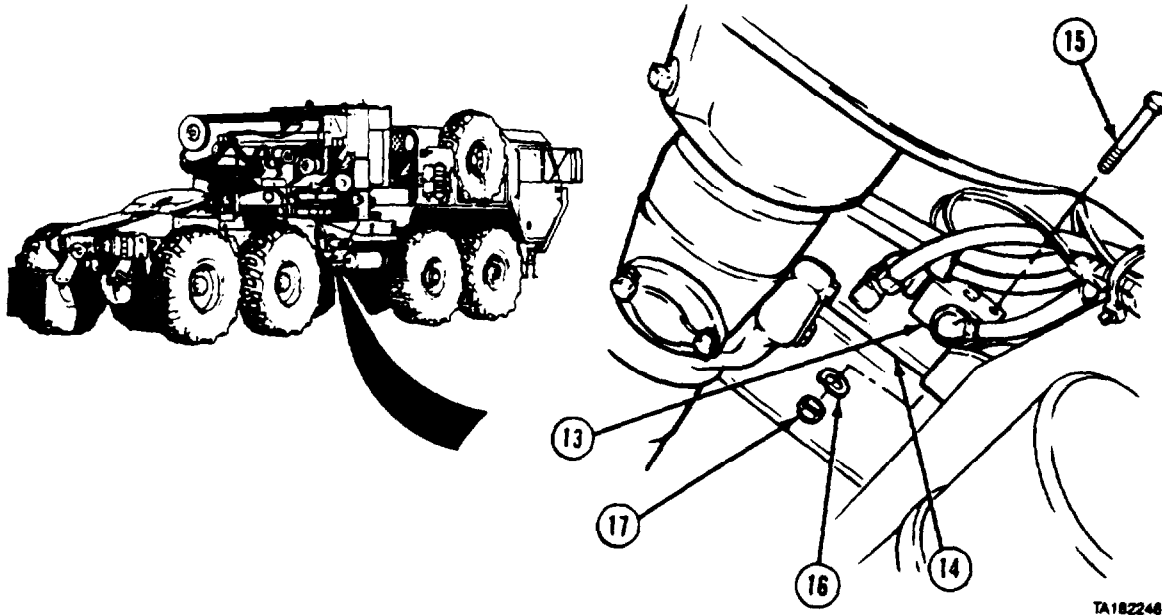
Do step (3) for arctic kit battery box only.

- (3) Install exhaust pipe (7) on battery box (1) with hose clamp (8).



Electrical System Maintenance Instructions (Cont)

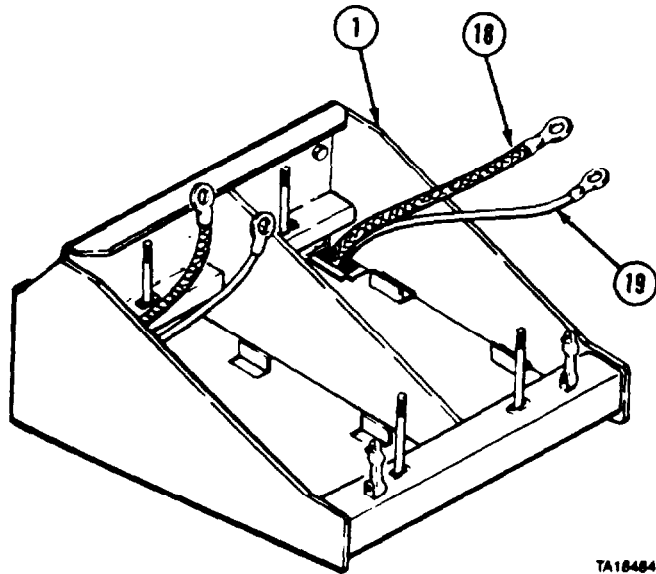
7-92. BATTERY BOX AND NATO CONNECTOR REMOVAL/REPAIR/INSTALLATION (CONT).



NOTE

Do step (4) for M983 only.

- (4) Install air manifold (13) on frame crossmember (14) with two screws (15), lockwashers (16), and nuts (17).
- (5) Pull battery cables (18) and STE/ICE wires (19) through holes in battery box (1).



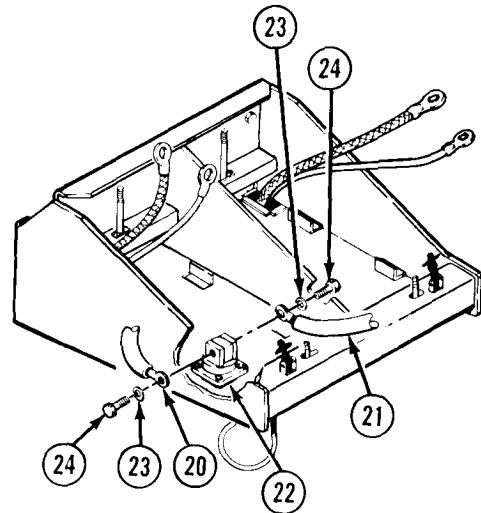
Electrical System Maintenance Instructions (Cont)

(6) Install two battery cables (20 and 21) on NATO connector (22) with two lockwashers (23) and screws (24).

e. Follow-on Maintenance.

- (1) Install No. 3 air reservoir (para 11-31).
- (2) Install No. 1 air reservoir (para 11-29).
- (3) Install batteries (para 7-90).
- (4) Install fire extinguisher (M978 only) (TM 9-2320-279-10).

END OF TASK



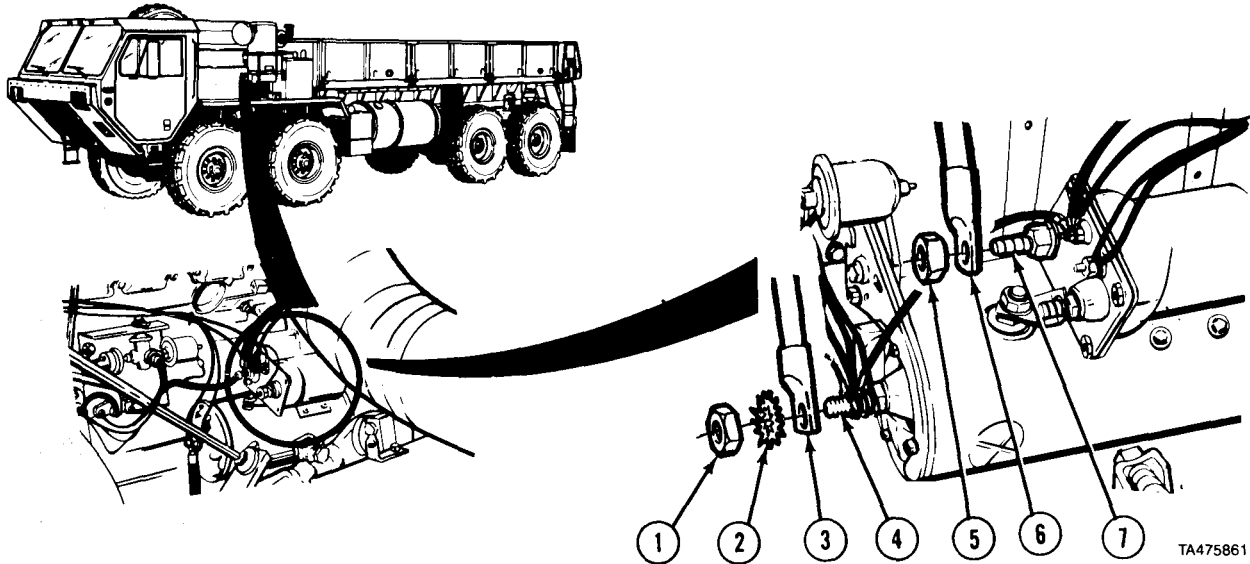
TA184819

| | |
|---|---|
| 7-92.1. NATO SLAVE RECEPTACLE AND BOX REMOVAL/REPAIR/INSTALLATION. | |
| This task covers: | |
| <ul style="list-style-type: none"> a. Removal b. Disassembly c. Assembly | <ul style="list-style-type: none"> d. Installation e. Follow-on Maintenance |
| INITIAL SETUP | |
| <i>Models</i> | <i>References</i> |
| All | None |
| <i>Test Equipment</i> | <i>Equipment Condition</i> |
| None | |
| <i>Special Tools</i> | <i>TM or Para</i> <i>Condition Description</i> |
| None | TM 9-2320-279-10 Left side engine panel removed. |
| | Para 7-91 Batteries disconnected. |
| <i>Supplies</i> | <i>Special Environmental Conditions</i> |
| Grease, automotive and artillery, Item 23, Appendix C | None |
| Adhesive sealant, silicone, Item 4, Appendix C | <i>General Safety Instructions</i> |
| Tags, identification, Item 48, Appendix C | None |
| Ties, cable, plastic, Item 52, Appendix C | |
| <i>Personnel Required</i> | |
| MOS 63S, Heavy wheel vehicle mechanic | |

Electrical System Maintenance Instructions (Cont)

7-92.1. NATO SLAVE RECEPTACLE AND BOX REMOVAL/REPAIR/INSTALLATION (CONT).

a. Removal.

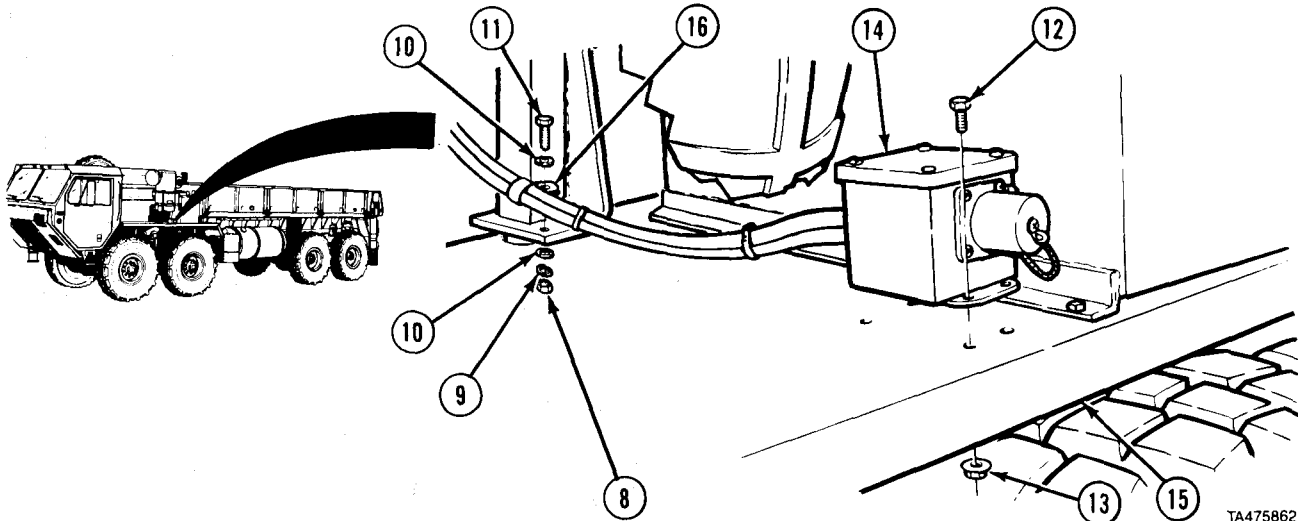


TA475861

NOTE

- Remove plastic cable ties as necessary.
- Tag and mark all wires.

- (1) Remove nut (1), lockwasher (2), and wire (3) from starter terminal (4).
- (2) Remove nut (5) and wire (6) from solenoid terminal (7).



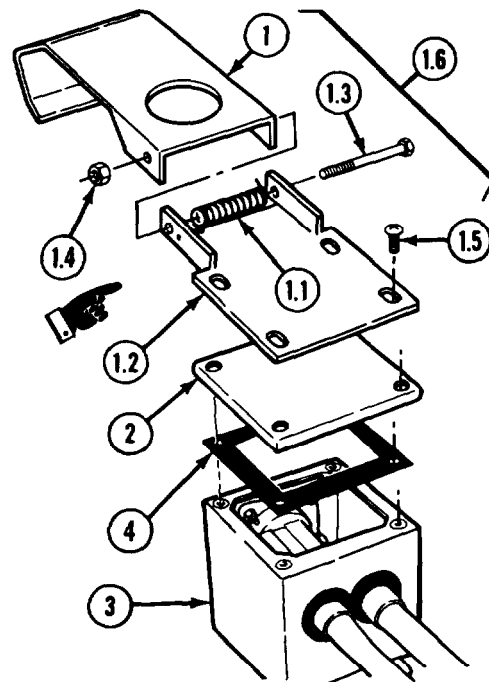
TA475862

- (3) Remove nut (8), lockwasher (9), washer (10), screw (11), and washer (10).
- (4) Remove four screws (12), locknuts (13), and box (14) from fender (15) and clamp (16).

Electrical System Maintenance Instructions (Cont)

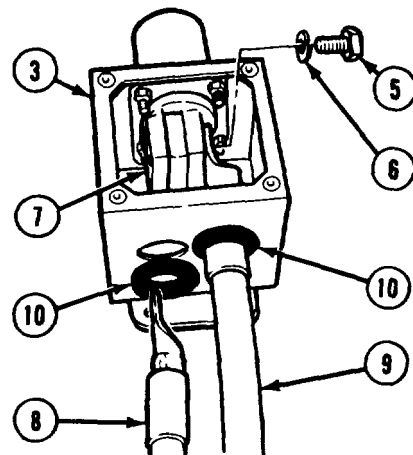
b. Disassembly.

- (1) Remove arm (1) and spring (1.1) from base (1.2) by removing screw (1.3) and nut (1.4).
- (1.1) Remove four screws (1.5), retention device (1.6), and cover (2) from box (3).
- (2) Remove gasket (4) from cover (2).

**NOTE**

Tag and mark all wires.

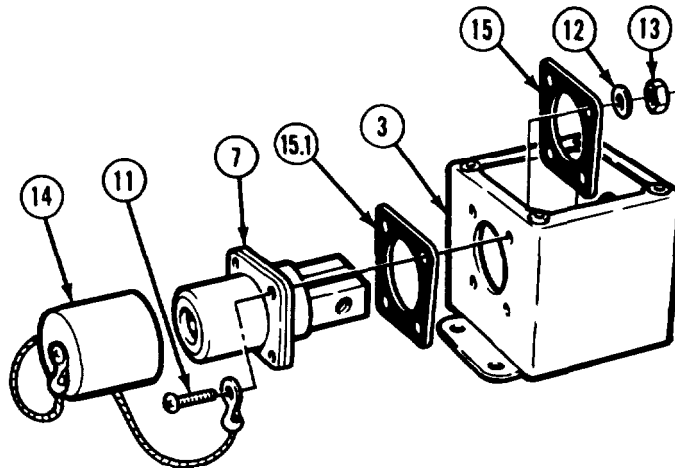
- (3) Remove two screws (5) and lockwashers (6) from receptacle (7).
- (4) Remove two wires (8 and 9) and grommets (10) from box (3).



Electrical System Maintenance Instructions (Cont)

7-92.1. NATO SLAVE RECEPTACLE AND BOX REMOVAL/REPAIR/INSTALLATION (CONT).

- (5) Remove four screws (11), washers (12), locknuts (13), and cap assembly (14) from receptacle (7).
- (6) Remove receptacle (7), insulator (15), and plastic insulator (15.1) from box (3).



c. Assembly.

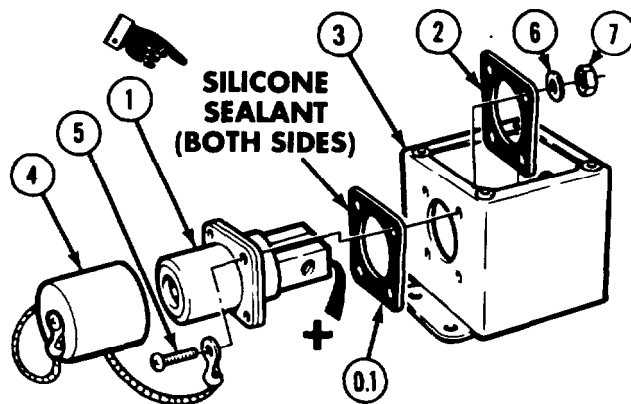
WARNING

Adhesives, solvents, and sealing compounds can burn easily, can give off harmful vapors, and are harmful to skin and clothing. To avoid injury or death, keep away from open fire and use in well-ventilated area. If adhesive, solvent, or sealing compound gets on skin or clothing, wash immediately with soap and water.

NOTE

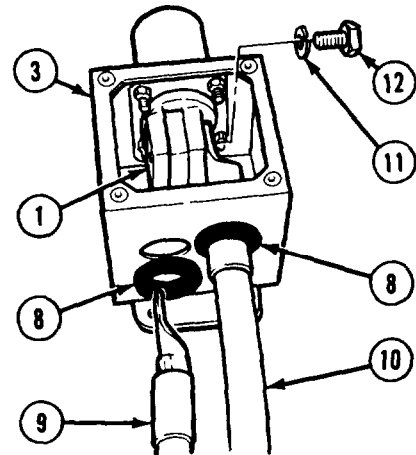
- When installing receptacle, make sure positive terminal (+) is on right side of box.
- M983 Tractors have a slave cable retention device on the NATO slave cable connector box. Other models do not.
- Insulator located between receptacle and box may be either plastic or rubber material. Rubber insulator does not need adhesive-sealant applied. Perform step (1) for plastic insulator only.

- (1) Apply silicone adhesive-sealant to both sides of plastic insulator (0.1).
- (1.1) Install receptacle (1), plastic insulator (0.1), and insulator (2) in box (3).
- (2) Install cap assembly (4) in receptacle (1) with four screws (5), washers (6), and locknuts (7). Put cap on receptacle.



Electrical System Maintenance Instructions (Cont)

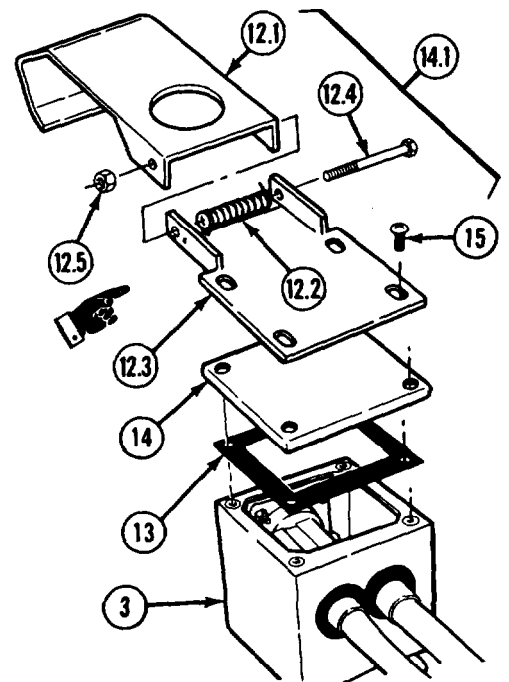
- (3) Install two grommets (8) in box (3).
- (4) Apply grease to grommets (8) and two wires (9 and 10) and install wires through grommets.
- (5) Connect two wires (9 and 10) to receptacle (1) with two lockwashers (11) and screws (12).



NOTE

If a slave cable with a small receptacle plug is being used, the retention arm needs to be bent 35°. Do step (5.1).

- (5.1) If slave cable with a small receptacle plug is being used, bend retention arm (12.1) 35°.
- (5.2) Install arm (12.1) and spring (12.21) on base (12.3) with screw (12.4) and nut (12.5).
- (6) Install gasket (13) in cover (14).
- (7) Install cover (14) and retention device (14.1) on box (3) with four screws (15).



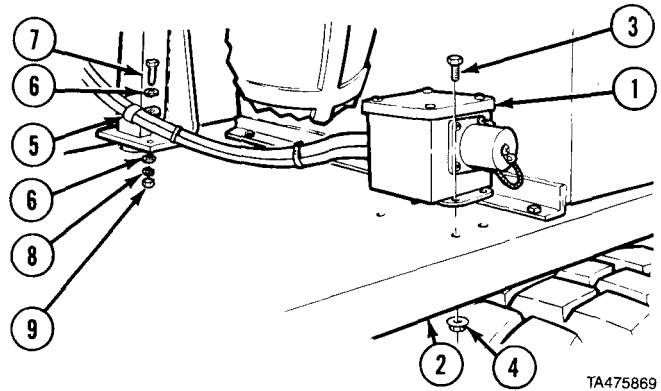
Electrical System Maintenance Instructions (Cont)

d. Installation.

NOTE

Replace plastic cable ties as necessary.

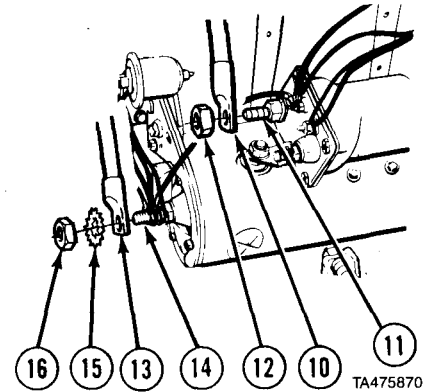
- (1) Install box (1) on fender (2) with four screws (3) and locknuts (4).
- (2) Install clamp (5), two washers (6), screw (7), lockwasher (8), and nut (9).



- (3) Install wire (10) on solenoid terminal (11) with nut (12).
- (4) Install wire (13) on starter ground terminal (14) with lockwasher (15) and nut (16).

e. Follow-on Maintenance.

- (1) Close left side engine cover (TM 9-2320-279-10).
- (2) Connect batteries (para 7-91).



END OF TASK

Section XI. CHASSIS WIRING COMPONENTS

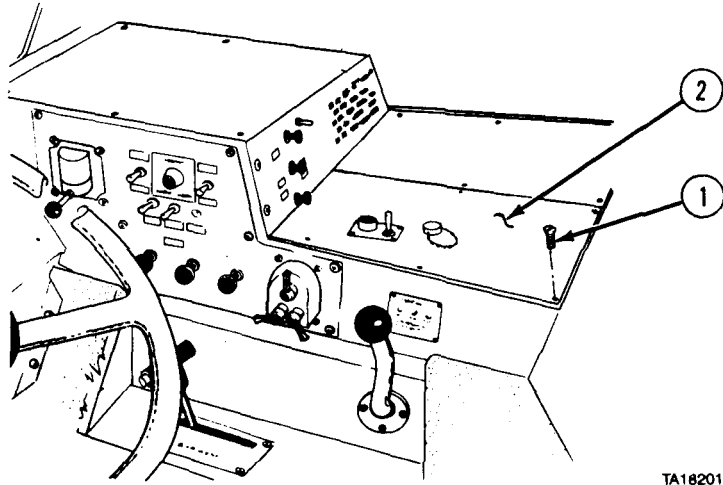
| | |
|---|--|
| 7-93. RESISTOR MODULE REMOVAL/INSTALLATION. | |
| This task covers: | |
| a. Removal | c. Follow-on Maintenance |
| b. Installation | |
| INITIAL SETUP | |
| <i>Models</i> | <i>References</i> |
| All | None |
| <i>Test Equipment</i> | <i>Equipment Condition</i> |
| None | <i>TM or Para</i> <i>Condition Description</i> |
| <i>Special Tools</i> | TM 9-2320-279-10 Shut off engine. |
| None | <i>Special Environmental Conditions</i> |
| <i>Supplies</i> | None |
| Tags, identification, Item 48, Appendix C | <i>General Safety Instructions</i> |
| <i>Personnel Required</i> | None |
| MOS 63S, Heavy wheel vehicle mechanic | |

Electrical System Maintenance Instructions (Cont)

7-93. RESISTOR MODULE REMOVAL/INSTALLATION (CONT).

a. Removal.

- (1) Remove eight screws (1) and heater compartment cover (2).

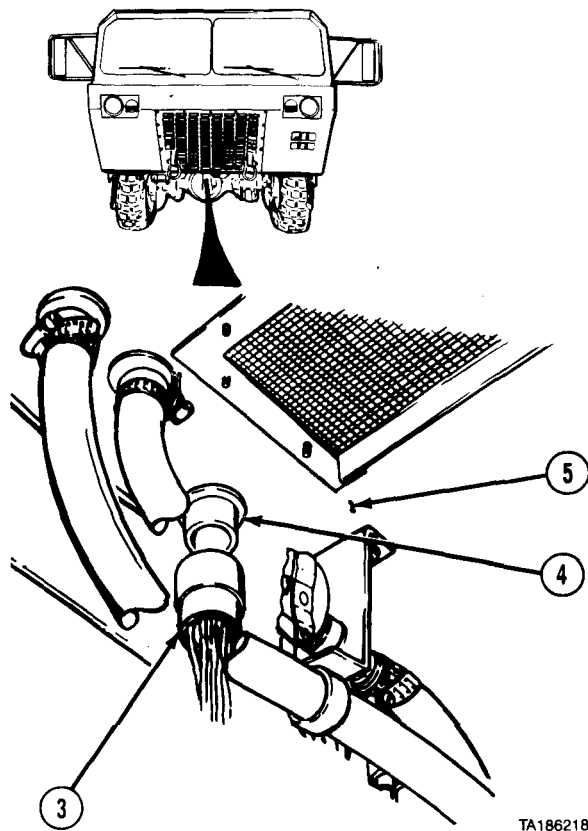


TA182013

NOTE

Tag and mark connectors before removing.

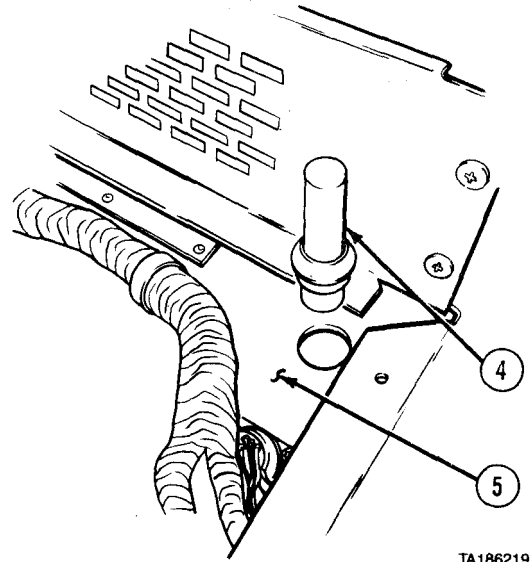
- (2) Remove connector (3) from resistor module (4).
- (3) Push resistor module (4) up in console (5).



TA186218

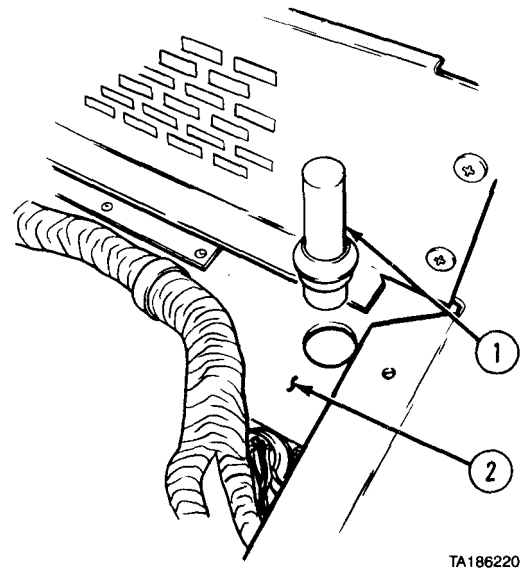
Electrical System Maintenance Instructions (Cont)

(4) Remove resistor module (4) from console (5).



b. Installation.

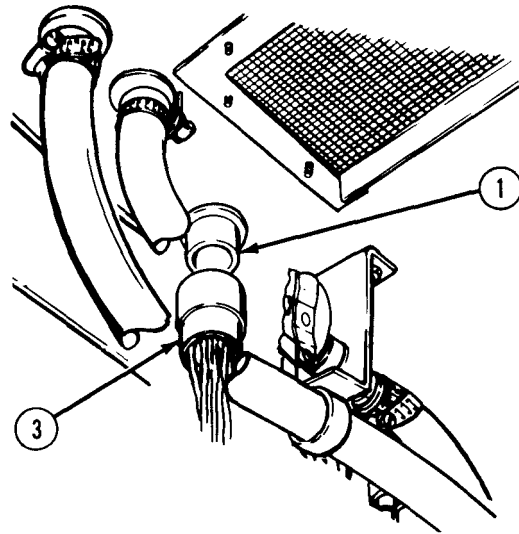
(1) Install resistor module (1) in console (2).



Electrical System Maintenance Instructions (Cont)

7-93. RESISTOR MODULE REMOVAL/INSTALLATION (CONT).

(2) Plug connector (3) into resistor module (1).

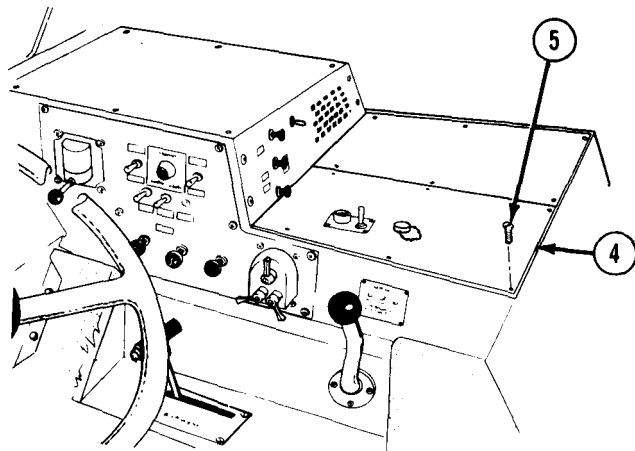


TA186221

(3) Install heater compartment cover (4) with eight screws (5).

c. *Follow-on Maintenance.* None.

END OF TASK



TA184750

Electrical System Maintenance Instructions (Cont)

| | |
|---|--|
| 7-94. STARTER RELAY REMOVAL/INSTALLATION. | |
| This task covers: | |
| a. Removal | c. Follow-on Maintenance |
| b. Installation | |
| INITIAL SETUP | |
| <i>Models</i> | <i>References</i> |
| All | None |
| <i>Test Equipment</i> | <i>Equipment Condition</i> |
| None | <i>TM or Para</i> <i>Condition Description</i> |
| <i>Special Tools</i> | TM 9-2320-279-10 Engine cover open. |
| None | TM 9-2320-279-10 Engine side panel removed. |
| <i>Supplies</i> | Para 7-91 Batteries disconnected. |
| Sealant, RTV200 Electrical, Item 45.05, Appendix C | <i>Special Environmental Conditions</i> |
| Tags, identification, Item 48, Appendix C | None |
| <i>Personnel Required</i> | <i>General Safety Instructions</i> |
| MOS 63S, Heavy wheel vehicle mechanic | None |

Electrical System Maintenance Instructions (Cont)

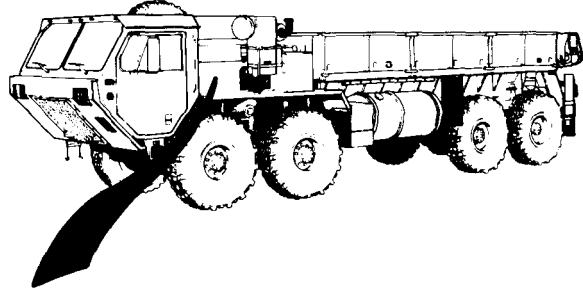
7-94. STARTER RELAY REMOVAL/INSTALLATION (CONT).

a. Removal.

NOTE

Tag and mark wires before removing.

- (1) Disconnect wires (1) from starter relay (2) terminals.
- (2) Remove two screws (3), lockwashers (4), and nuts (5).
- (3) Remove starter relay (2).

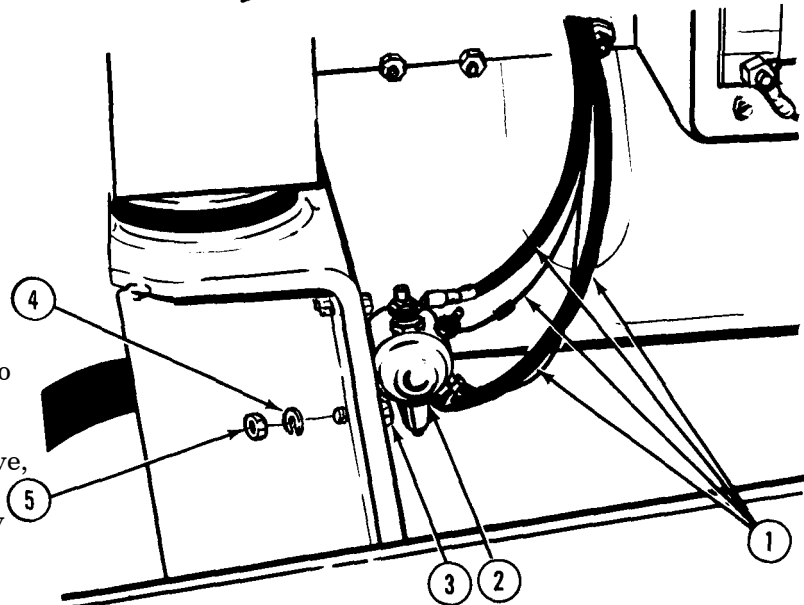


b. Installation.

- (1) Place starter relay (2) on engine front support.
- (2) Install two screws (3), lockwashers (4), and nuts (5).

WARNING

Adhesives, solvents, and sealing compounds can burn easily, can give off harmful vapors, and are harmful to skin and clothing. To avoid injury or death, keep away from open fire and use in well-ventilated area. If adhesive, solvent, or sealing compound gets on skin or clothing, wash immediately with soap and water.



NOTE

Apply electrical sealant to exposed wire connectors after installing connectors.

- (3) Connect wires (1) to starter relay (2) terminals.

c. Follow-on Maintenance.

- (1) Connect batteries (para 7-91).
- (2) Install engine side panel (TM 9-2320-279-10).
- (3) Close engine cover (TM 9-2320-279-10).
- (4) Start engine to check operation of relay (TM 9-2320-279-10).
- (5) Shut off engine (TM 9-2320-279-10).

END OF TASK

Electrical System Maintenance Instructions (Cont)

7-95. PTO INDICATOR LIGHT ASSEMBLY, SWITCH, AND HARNESS
REMOVAL/INSTALLATION.

This task covers:

- a. Removal
- b. Installation

c. Follow-on Maintenance

INITIAL SETUP

Models

All

Test Equipment

None

Special Tools

None

Supplies

Connector, butt, electrical, Item 19,
Appendix C
Tags, identification, Item 48, Appendix C

Personnel Required

MOS 63S, Heavy wheel vehicle mechanic

References

None

Equipment Condition

TM or Para

Para 7-91

Condition Description

Batteries disconnected.

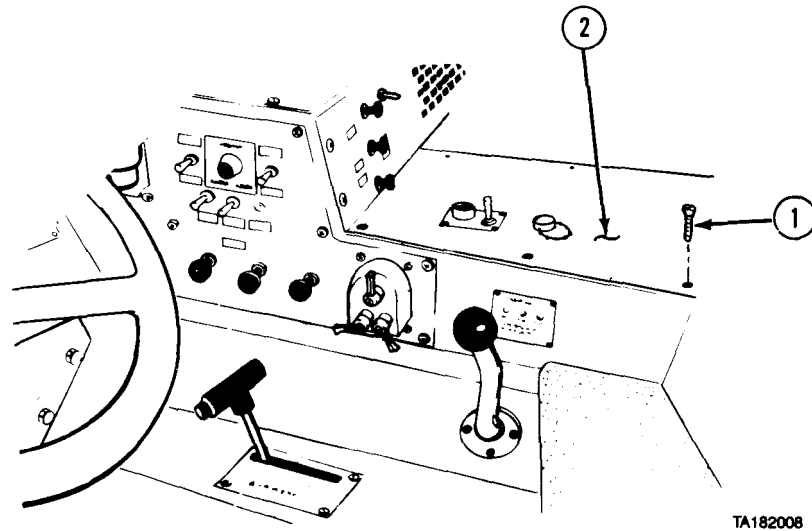
Special Environmental Conditions

None

General Safety Instructions

None

a. Removal.



(1) Remove six screws (1) and heater compartment cover (2) from console.

Electrical System Maintenance Instructions (Cont)

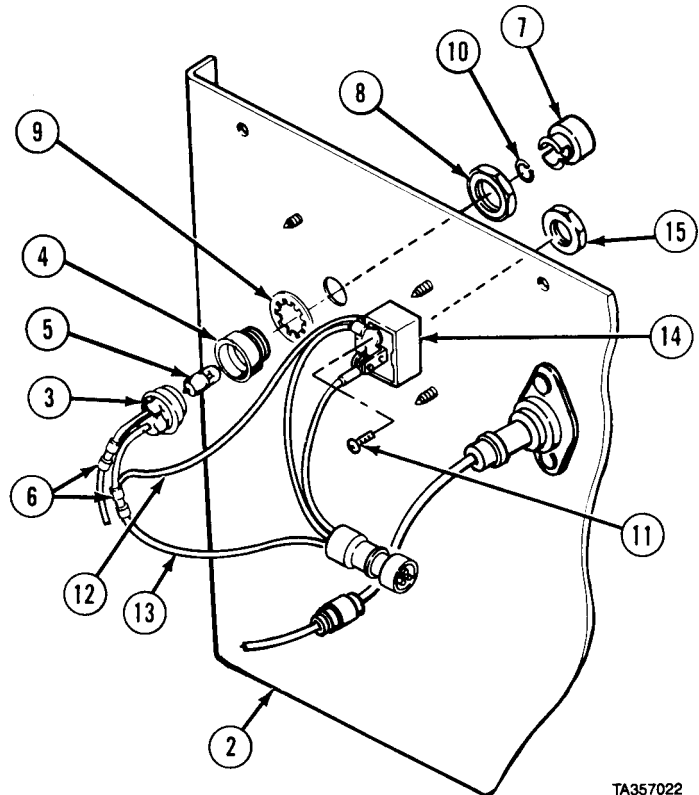
7-95. PTO INDICATOR LIGHT ASSEMBLY, SWITCH, AND HARNESS
REMOVAL/INSTALLATION (CONT).

- (2) Pull out socket (3) from housing (4).
- (3) Remove lamp (5) from socket (3).

NOTE

Tag and mark wires before disconnecting or removing.

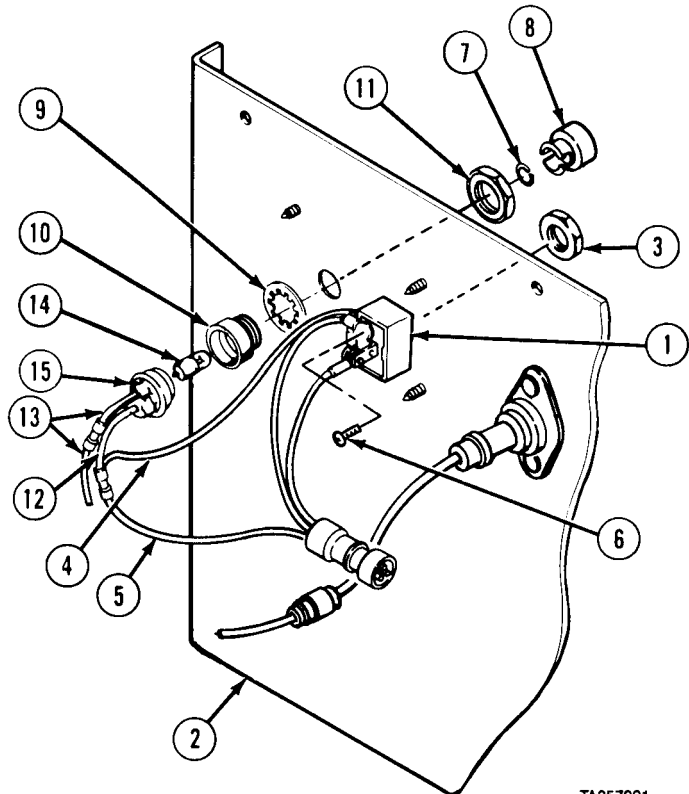
- (4) Remove two electrical butt connectors (6).
- (5) Remove lens (7), nut (8), housing (4), and lockwasher (9) from heater compartment cover (2).
- (6) Remove force ring (10) from lens (7).
- (7) Remove two screws (11), wire (12), and harness (13) from PTO switch (14).
- (8) Disconnect harness (13) from vehicle wiring.
- (9) Remove nut (15) from PTO switch (14). Remove PTO switch from heater compartment cover (2).



TA357022

b. Installation.

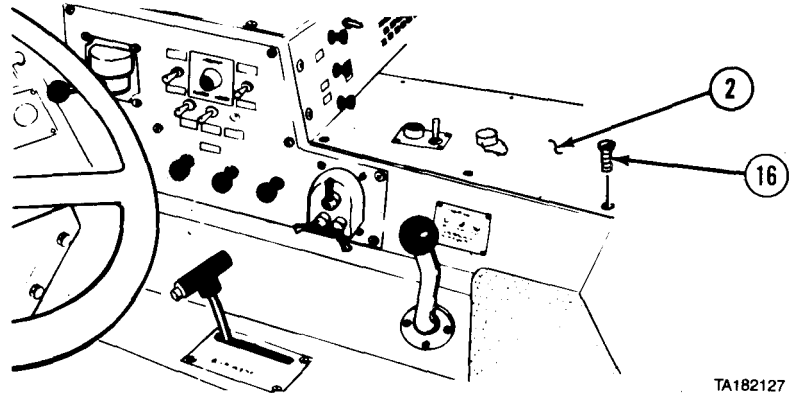
- (1) Install PTO switch (1) on heater compartment cover (2) with nut (3).
- (2) Install wire (4) and harness (5) on PTO switch (1) with two screws (6).
- (3) Connect harness (5) to vehicle wiring.
- (4) Install force ring (7) into lens (8).
- (5) Install lockwasher (9), housing (10), nut (11), and lens (8) on heater compartment cover (2).
- (6) Connect two wires (4 and 12) to harness (5).
- (7) Connect two wires (13).
- (8) Install lamp (14) into socket (15) and install socket into housing (10).



TA357021

Electrical System Maintenance Instructions (Cont)

- (9) Install heater compartment cover (2) with six screws (16).
- c. Follow-on Maintenance.
 - (1) Connect batteries (para 7-91).
 - (2) Check operation of PTO switch and indicator light (TM 9-2320-279-10).

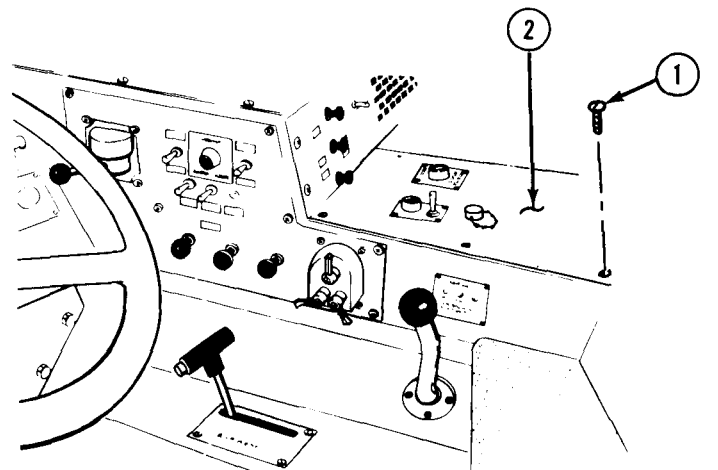


END OF TASK

TA182127

| | |
|--|---|
| 7-96. CRANE OUTRIGGER EXTENDED LIGHT ASSEMBLY REMOVAL/INSTALLATION (M983, M984, M985E1). | |
| This task covers: | |
| a. Removal | c. Follow-on Maintenance |
| b. Installation | |
| INITIAL SETUP | |
| <i>Models</i> | <i>References</i> |
| M983, M984, M985E1 | None |
| <i>Test Equipment</i> | <i>Equipment Condition</i> |
| None | TM or Para Condition Description |
| <i>Special Tools</i> | Para 7-91 Batteries disconnected. |
| None | |
| <i>Supplies</i> | <i>Special Environmental Conditions</i> |
| Connector, electrical, butt, Item 19, Appendix C | None |
| <i>Personnel Required</i> | <i>General Safety Instructions</i> |
| MOS 63S, Heavy wheel vehicle mechanic | None |

- a. Removal.
 - (1) Remove six screws (1) and heater compartment cover (2) from console.



TA182016

Electrical System Maintenance Instructions (Cont)

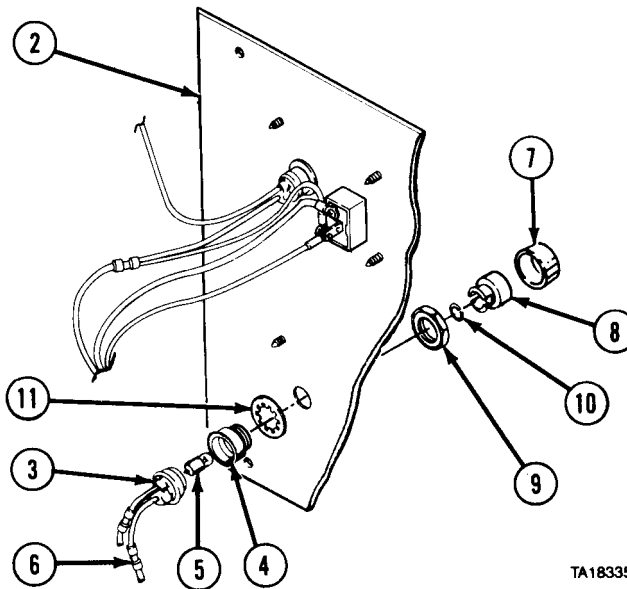
7-96. CRANE OUTRIGGER EXTENDED LIGHT ASSEMBLY REMOVAL/INSTALLATION (M983, M984, M985E1) (CONT).

- (2) Pull out socket (3) from housing (4).
- (3) Remove lamp (5) from socket (3).

NOTE

Tag and mark wires before disconnecting or removing.

- (4) Cut two wires at electrical butt connectors (6) and remove socket (3).
- (5) Remove light shield (7), lens (8), and nut (9) from heater compartment cover (2). Remove lens from light shield. Remove force ring (10) from lens.
- (6) Remove housing (4) and lockwasher (11).



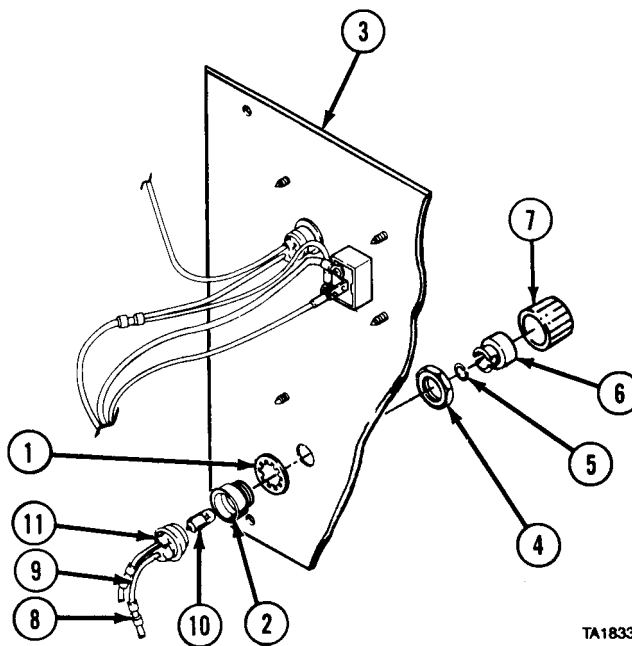
b. Installation.

- (1) Install lockwasher (1) on housing (2). Install housing in heater compartment cover (3) and secure with nut (4).
- (2) Install force ring (5) in lens (6). Install lens in light shield (7). Install light shield on heater compartment cover (3).

NOTE

Two wires are interchangeable when connecting wires to socket wires.

- (3) Install electrical butt connectors (8) on two wires (9) and crimp electrical butt connectors securely.
- (4) Install lamp (10) in socket (11).
- (5) Install socket (11) in housing (2).

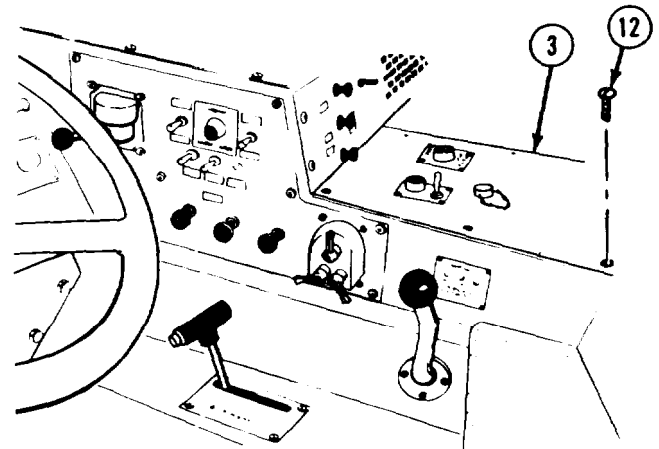


Electrical System Maintenance Instructions (Cont)

- (6) Attach heater compartment cover (3) to console with six screws (12).

c. Follow-on Maintenance.

- (1) Connect batteries (para 7-91).
- (2) Check operation of crane outrigger extended light
(M983) (TM 9-2320-279-10)
(M984) (TM 9-2320-354-10)
(M985E1) (TM 9-2320-354-10).



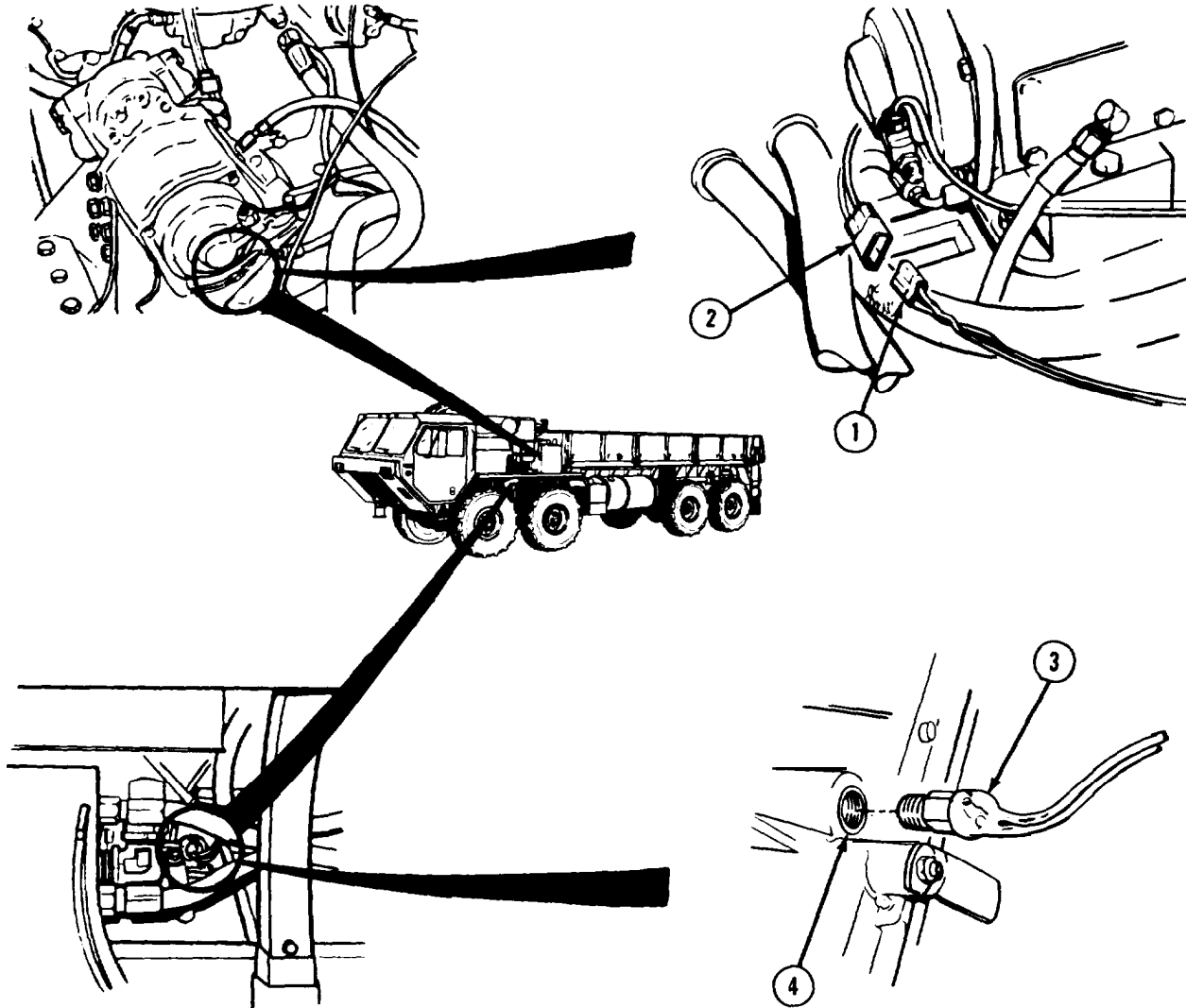
END OF TASK

| 7-97. NEUTRAL INTERLOCK SWITCH SENDER UNIT REMOVAL/INSTALLATION. | |
|---|--|
| This task covers: | |
| a. Removal | c. Follow-on Maintenance |
| b. Installation | |
| INITIAL SETUP | |
| Models All | References None |
| Test Equipment None | Equipment Condition |
| Special Tools Socket, special J33410 | TM or Para Condition Description TM 9-2320-279-10 Front cargo body panel removed (M977 and M985). |
| Supplies None | Para 16-13 Left front splash guard removed. |
| Personnel Required MOS 63S, Heavy wheel vehicle mechanic | Special Environmental Conditions None |
| | General Safety Instructions None |

Electrical System Maintenance Instructions (Cont)

7-97. NEUTRAL INTERLOCK SWITCH SENDER UNIT REMOVAL/INSTALLATION (CONT).

a. Removal.



- (1) Disconnect wires (1) at connector (2).
- (2) Remove sender unit (3) from transmission housing (4).

b. Installation.

- (1) Install sender unit (3) in transmission housing (4). Tighten sender unit to 50 to 60 lb-ft (68 to 81 N•m) using special socket.
- (2) Connect wires (1) at connector (2).

c. Follow-on Maintenance.

- (1) Install front cargo body panel (TM 9-2320-279-10).
- (2) Install left front splash guard (para 16-13).

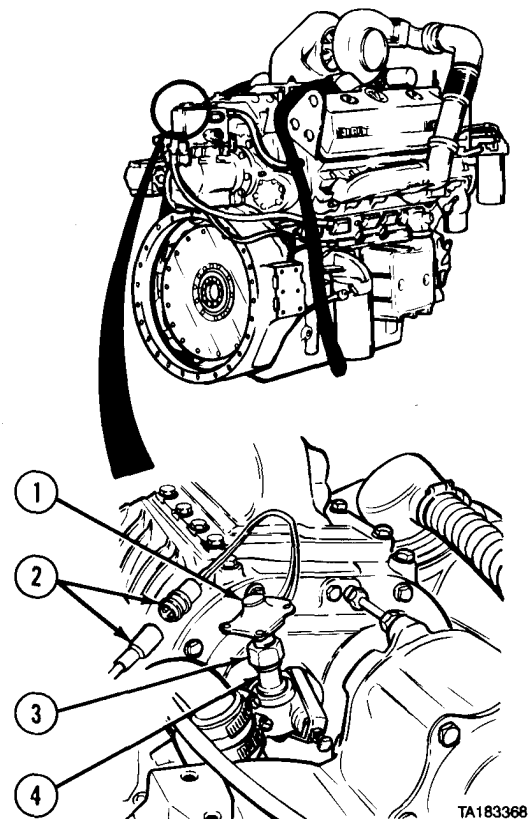
END OF TASK

Electrical System Maintenance Instructions (Cont)

| | |
|---|--|
| 7-98. TACHOMETER SENDING UNIT REMOVAL/INSTALLATION. | |
| This task covers: | |
| a. Removal | c. Follow-on Maintenance |
| b. Installation | |
| INITIAL SETUP | |
| <i>Models</i> | <i>References</i> |
| All | None |
| <i>Test Equipment</i> | <i>Equipment Condition</i> |
| None | <i>TM or Para</i> <i>Condition Description</i> |
| <i>Special Tools</i> | TM 9-2320-279-10 Engine cover open. |
| None | TM 9-2320-279-10 Engine side panel removed. |
| <i>Supplies</i> | Para 7-91 Batteries disconnected. |
| None | <i>Special Environmental Conditions</i> |
| <i>Personnel Required</i> | None |
| MOS 63S, Heavy wheel vehicle mechanic | <i>General Safety Instructions</i> |
| | None |

- a. *Removal.*
 - (1) Disconnect tachometer sending unit (1) at connectors (2).
 - (2) Loosen nut (3) and remove tachometer sending unit (1) from tachometer drive (4).
- b. *Installation.*
 - (1) Install tachometer sending unit (1) on tachometer drive (4) by alining tang with groove. Tighten nut (3).
 - (2) Connect connectors (2).
- c. *Follow-on Maintenance.*
 - (1) Connect batteries (para 7-91).
 - (2) Start engine and check operation of tachometer sending unit (TM 9-2320-279-10).
 - (3) Shut off engine (TM 9-2320-279-10).
 - (4) Install engine side panel (TM 9-2320-279-10).
 - (5) Install engine cover (TM 9-2320-279-10).

END OF TASK



TA183368

Electrical System Maintenance Instructions (Cont)

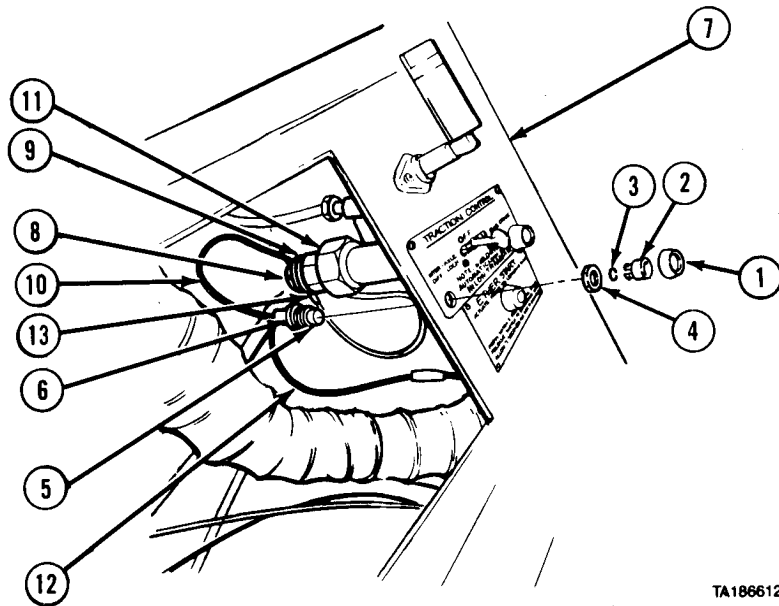
| | | |
|---|---|------------------------------|
| 7-99. TRACTION CONTROL INDICATOR LIGHT ASSEMBLY REMOVAL/INSTALLATION. | | |
| This task covers: | | |
| a. Removal | c. Follow-on Maintenance | |
| b. Installation | | |
| INITIAL SETUP | | |
| <i>Models</i> | <i>References</i> | |
| All | None | |
| <i>Test Equipment</i> | <i>Equipment Condition</i> | |
| None | <i>Till or Para</i> | <i>Condition Description</i> |
| <i>Special Tools</i> | Para 7-19 | Instrument panel removed. |
| None | <i>Special Environmental Conditions</i> | |
| <i>Supplies</i> | None | |
| None | <i>General Safety Instructions</i> | |
| <i>Personnel Required</i> | None | |
| MOS 63S, Heavy wheel vehicle mechanic | | |

a. Removal.

NOTE

INTER-AXLE DIFF. LOCK and 8X8 DRIVE indicator lights are removed the same way. INTER-AXLE DIFF. LOCK indicator light is shown.

- (1) Remove two light shields (1) and lenses (2). Remove lenses from light shields. Remove force rings (3) from lenses.
- (2) Remove two nuts (4).
- (3) Remove two TRACTION CONTROL indicator lights (5) and washers (6) from panel (7).
- (4) Remove screw (8), lockwasher (9), and wire (10) from TRACTION CONTROL switch (11).
- (5) Cut ground wire (12) at electrical butt connector.



TA186612

Electrical System Maintenance Instructions (Cont)

b. Installation.

NOTE

INTER-AXLE DIFF. LOCK and 8X8 DRIVE indicator lights are installed the same way. INTER-AXLE DIFF. LOCK indicator light is shown.

- (1) Crimp ring terminal (13) on wire (10) of TRACTION CONTROL indicator light (5).
- (2) Connect ring terminal (13) with screw (8) and lockwasher (9) to TRACTION CONTROL switch (11).
- (3) Connect wire (12) of TRACTION CONTROL indicator light (5) to ground wire (12).
- (4) Insert two TRACTION CONTROL indicator lights (5) through mounting hole in panel (7).
- (5) Install two nuts (4) and washers (6).
- (6) Install two force rings (3) in lenses (2). Install lenses into light shields (1). Install light shields.

c. Follow-on Maintenance.

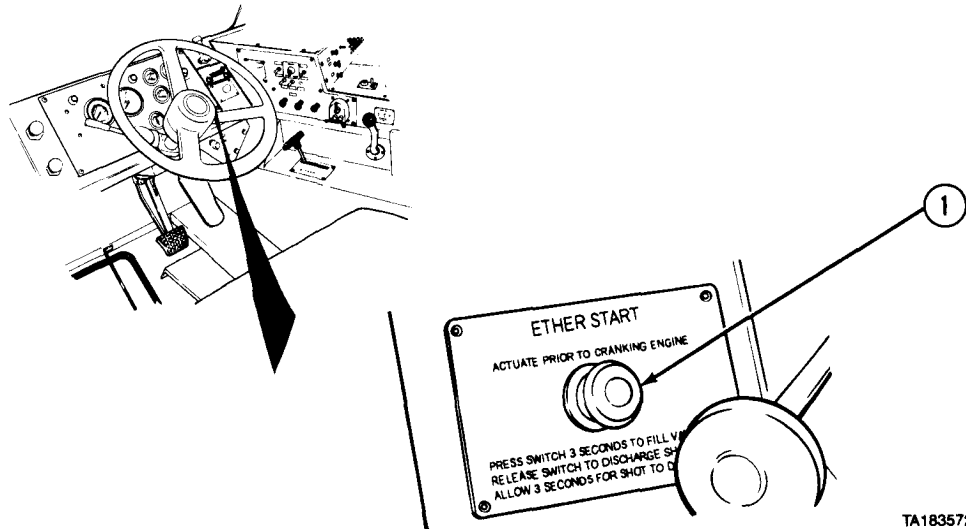
- (1) Install instrument panel (para 7-19).
- (2) Check operation of TRACTION CONTROL indicator light assembly (TM 9-2320-279-10).

END OF TASK

Electrical System Maintenance Instructions (Cont)

| | |
|---|--|
| 7-100. ETHER START SWITCH REMOVAL/INSTALLATION. | |
| This task covers: | |
| a. Removal | c. Follow-on Maintenance |
| b. Installation | |
| INITIAL SETUP | |
| <i>Models</i> | <i>References</i> |
| All | None |
| <i>Test Equipment</i> | <i>Equipment Condition</i> |
| None | <i>TM or Para</i> <i>Condition Description</i> |
| <i>Special Tools</i> | Para 7-19 Instrument panel removed. |
| None | <i>Special Environmental Conditions</i> |
| <i>Supplies</i> | None |
| Tags, identification, Item 48, Appendix C | <i>General Safety Instructions</i> |
| <i>Personnel Required</i> | None |
| MOS 63S, Heavy wheel vehicle mechanic | |

a. Removal.



TA183572

NOTE

Rubber boot will come off with knurled nut.

(1) Remove knurled nut (1).

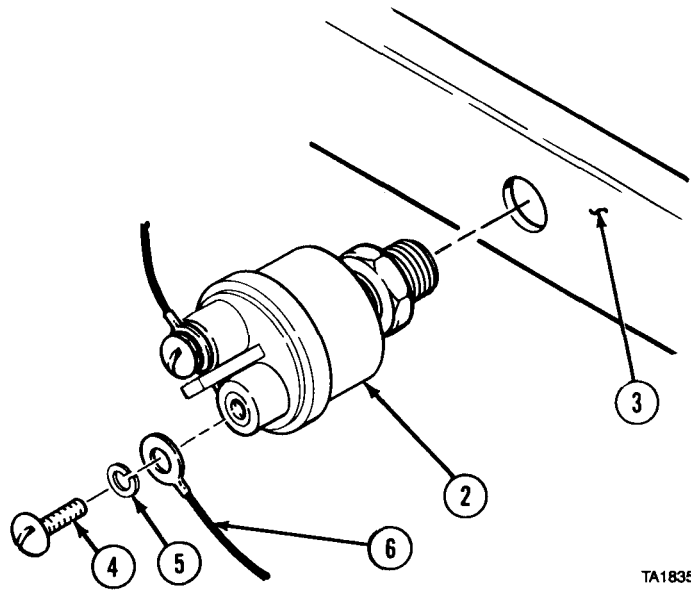
Electrical System Maintenance Instructions (Cont)

- (2) Remove ETHER START switch (2) from panel (3).

NOTE

Tag and mark wires before removing.

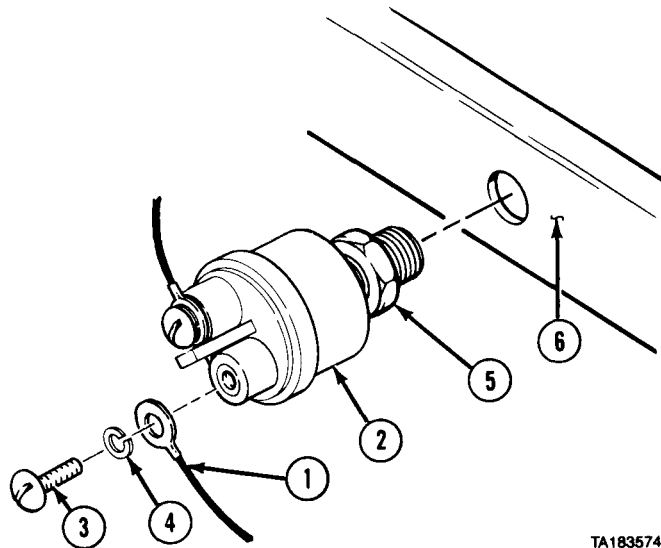
- (3) Remove two screws (4), lockwashers (5), and wires (6) from ETHER START switch (2).



TA183573

b. Installation.

- (1) Install two wires (1) to ETHER START switch (2) with two screws (3) and lockwashers (4).
- (2) Adjust jamnut (5) until there is approximately 1/4 in. (6 mm) of threads between jamnut and end of threaded portion of ETHER START switch (2).
- (3) Install ETHER START switch (2) in panel (6).



TA183574

Electrical System Maintenance Instructions (Cont)

7-100. ETHER START SWITCH REMOVAL/INSTALLATION (CONT).

NOTE

If switch is loose in panel after tightening knurled nut, remove ETHER START switch and turn jamnut counterclockwise two turns. Repeat procedure as necessary until ETHER START switch is tight.

(4) Install and tighten knurled nut (7).

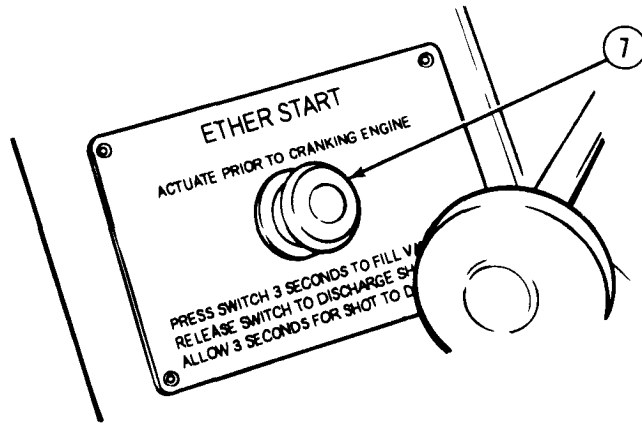
c. Follow-on Maintenance.

(1) Install instrument panel (para 7-19).

NOTE

Coolant temperature must be below 55°F (13°C) to activate ETHER START.

(2) Check operation of ETHER START switch (TM 9-2320-279-10).



TA183575

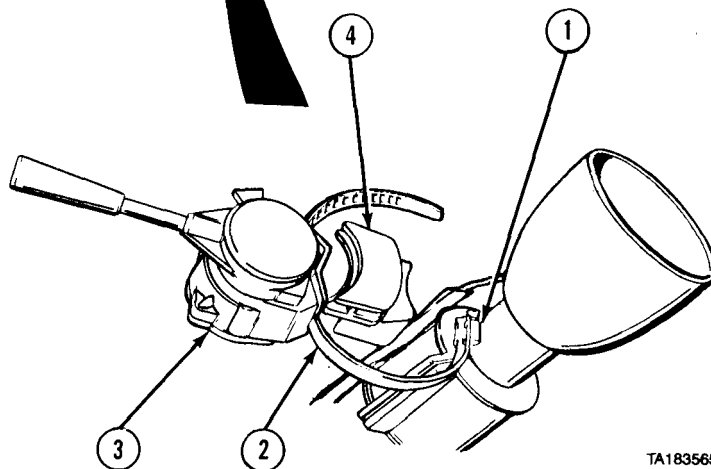
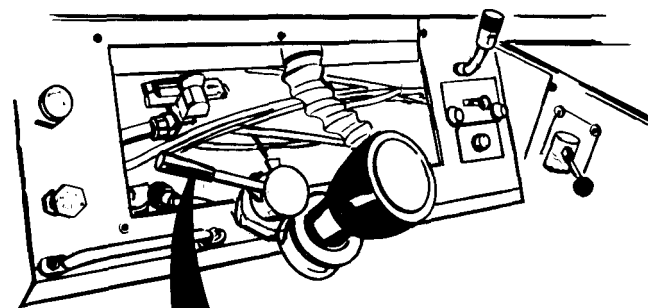
END OF TASK

| | |
|---|---|
| 7-101. HORN SWITCH CONTACT ROLLER REMOVAL/INSTALLATION. | |
| This task covers: | |
| a. Removal | c. Follow-on Maintenance |
| b. Installation | |
| INITIAL SETUP | |
| <i>Models</i> | <i>References</i> |
| All | None |
| <i>Test Equipment</i> | <i>Equipment Condition</i> |
| None | <i>TM or Para</i> |
| <i>Special Tools</i> | Para 7-19 |
| None | Para 13-2 |
| <i>Supplies</i> | <i>Condition Description</i> |
| Tape, insulation, electrical, Item 50, | Instrument panel removed. |
| Appendix C | Steering wheel removed. |
| Ties, cable, plastic, Item 52, Appendix C | <i>Special Environmental Conditions</i> |
| <i>Personnel Required</i> | None |
| MOS 63S, Heavy wheel vehicle mechanic | <i>General Safety Instructions</i> |
| | None |

Electrical System Maintenance Instructions (Cont)

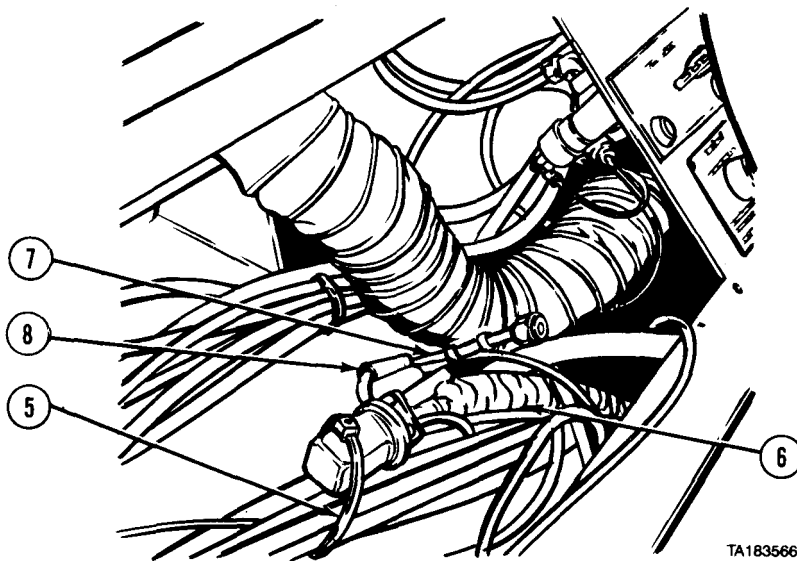
a. Removal.

- (1) Loosen screw (1) and strap (2) on turn signal switch (3) and mounting base (4).



TA183565

- (2) Remove plastic cable tie (5) from wire harness (6).
- (3) Disconnect yellow wire (7) at plug-in connector (8).

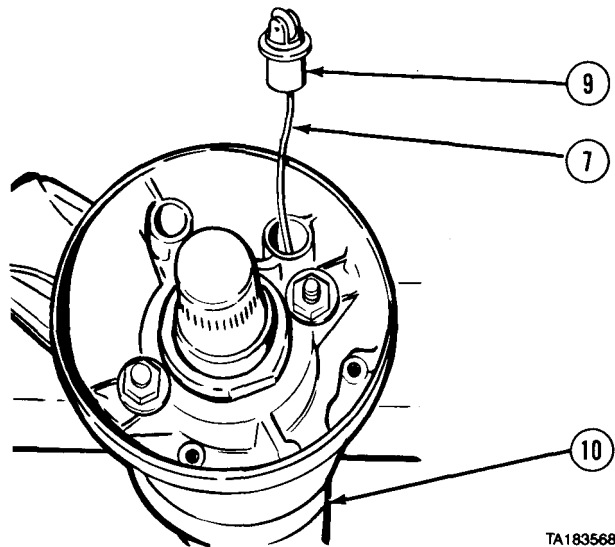


TA183566

Electrical System Maintenance Instructions (Cont)

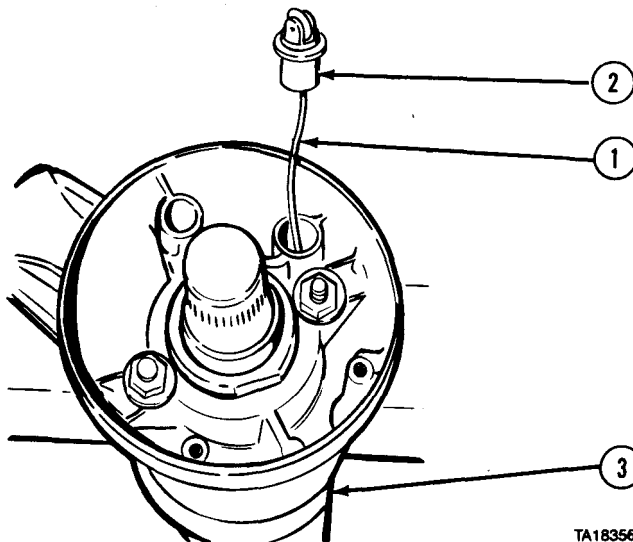
7-101. HORN SWITCH CONTACT ROLLER REMOVAL/INSTALLATION (CONT).

- (4) Remove horn switch contact roller (9) and yellow wire (7) from steering column (10).

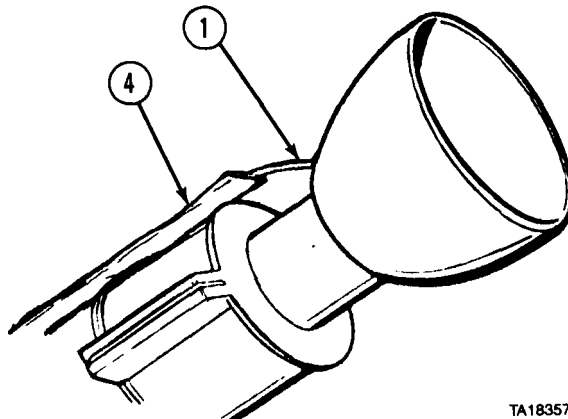


b. Installation.

- (1) Thread yellow wire (1) of horn switch contact roller (2) down in steering column (3).
- (2) Seat horn switch contact roller (2) in steering column (3).

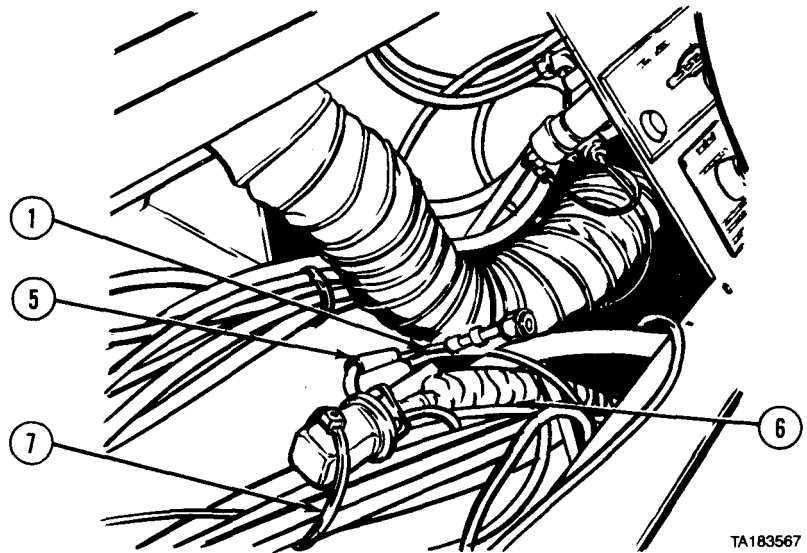


- (3) Thread yellow wire (1) through tubing (4).



Electrical System Maintenance Instructions (Cont)

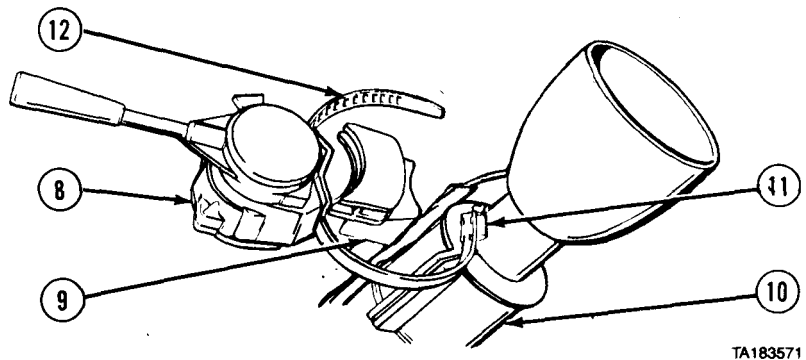
- (4) Connect yellow wire (1) to plug-in connector (5). Wrap wire harness (6) and yellow wire with tape and plastic cable tie (7).



- (5) Position turn signal switch (8) and mounting base (9) on steering column (10) and tighten screw (11) on strap (12).

c. *Follow-on Maintenance.*

- (1) Install instrument panel (para 7-19).
 (2) Install steering wheel (para 13-2).
 (3) Check operation of horn switch (TM 9-2320-279-10).

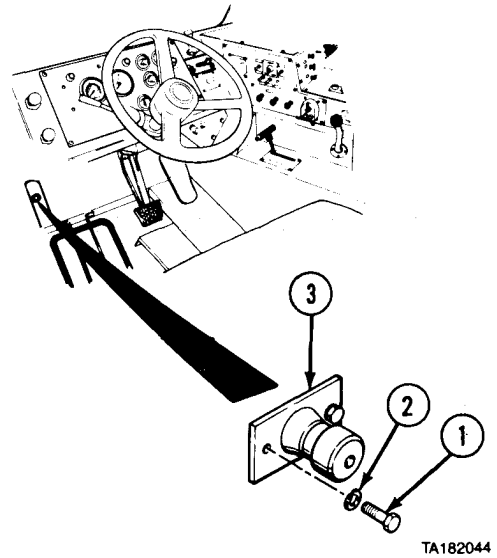


END OF TASK

Electrical System Maintenance Instructions (Cont)

| | |
|--|--|
| 7-102. DIMMER SWITCH REMOVAL/INSTALLATION. | |
| This task covers: | |
| a. Removal | c. Follow-on Maintenance |
| b. Installation | |
| INITIAL SETUP | |
| <i>Models</i> | <i>References</i> |
| All | None |
| <i>Test Equipment</i> | <i>Equipment Condition</i> |
| None | <i>TM or Para</i> <i>Condition Description</i> |
| <i>Special Tools</i> | Para 7-91 Batteries disconnected. |
| None | <i>Special Environmental Conditions</i> |
| <i>Supplies</i> | None |
| Tags, identification, Item 48, Appendix C | <i>General Safety Instructions</i> |
| <i>Personnel Required</i> | None |
| MOS 63S, Heavy wheel vehicle mechanic | |

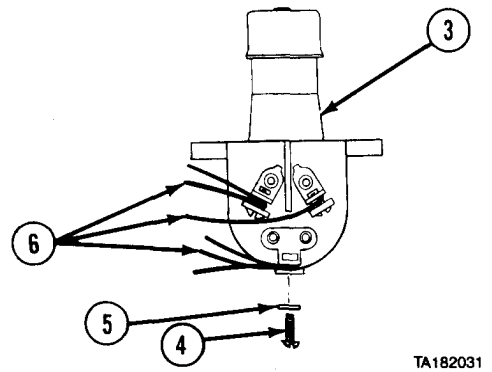
- a. Removal.
- (1) Remove two screws (1), lockwashers (2), and dimmer switch (3).



NOTE

Tag and mark wires before disconnecting.

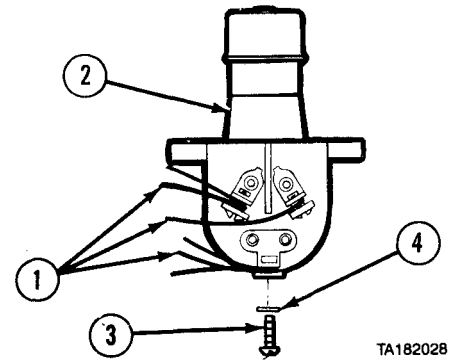
- (2) Remove three screws (4), washers (5), and disconnect six wires (6) from dimmer switch (3).



Electrical System Maintenance Instructions (Cont)

b. Installation.

(1) Connect six wires (1) to dimmer switch (2) with three screws (3) and washers (4).

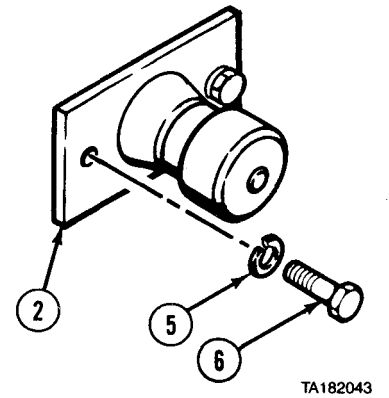


(2) Install dimmer switch (2) with two lockwashers (5) and screws (6).

c. Follow-on Maintenance.

(1) Connect batteries (para 7-91).

(2) Check operation of dimmer switch (TM 9-2320-279-10).

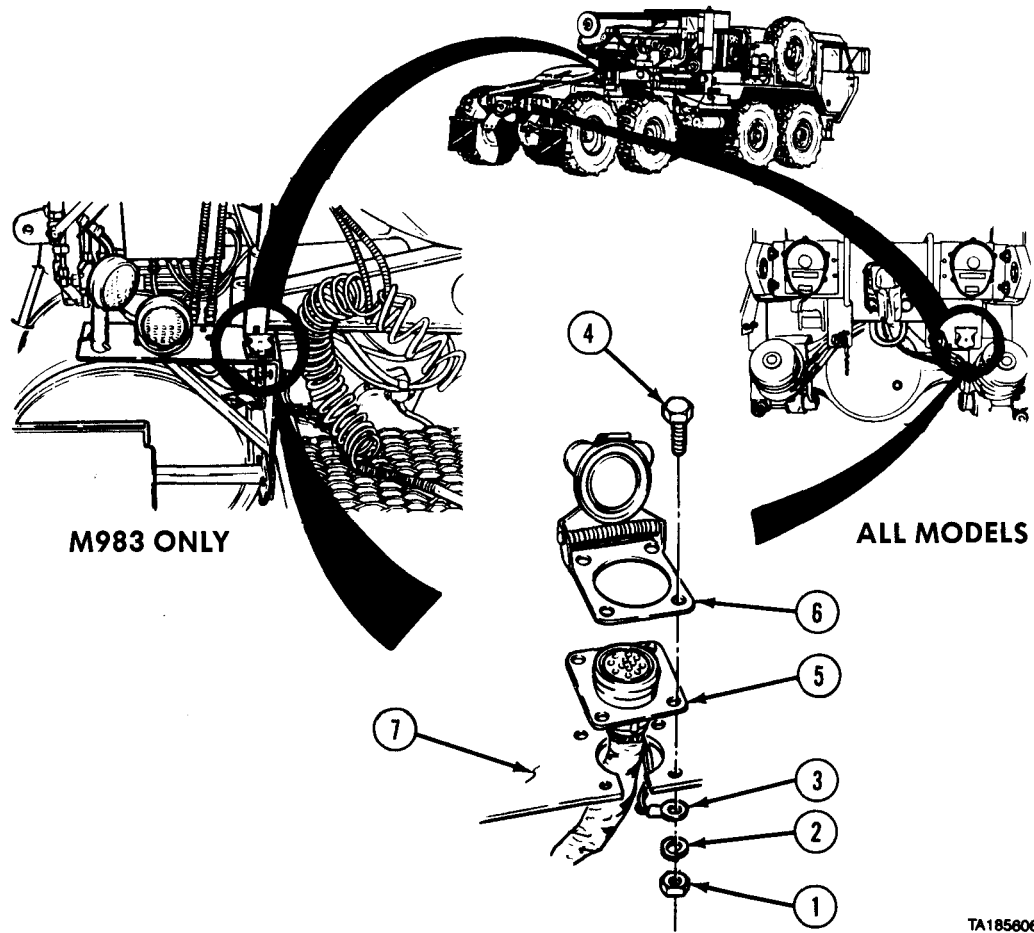


END OF TASK

| | |
|--|--|
| 7-103. TRAILER ELECTRICAL CONNECTOR REMOVAL/INSTALLATION (M983). | |
| This task covers: | |
| a. Removal | c. Follow-on Maintenance |
| b. Installation | |
| INITIAL SETUP | |
| <i>Models</i> | <i>References</i> |
| All | None |
| <i>Test Equipment</i> | <i>Equipment Condition</i> |
| None | <i>TM or Para</i> <i>Condition Description</i> |
| <i>Special Tools</i> | Para 7-91 Disconnect batteries. |
| None | <i>Special Environmental Conditions</i> |
| <i>Supplies</i> | None |
| Tags, identification, Item 48, Appendix C | <i>General Safety Instructions</i> |
| Ties, cable, plastic, Item 52, Appendix C | None |
| <i>Personnel Required</i> | |
| MOS 63S, Heavy wheel vehicle mechanic | |

Electrical System Maintenance Instructions (Cont)

7-103. TRAILER ELECTRICAL CONNECTOR REMOVAL/INSTALLATION (M983) (CONT).



a. Removal.

NOTE

- Remove plastic cable ties as required.
- Ground wire will come free when right-rear screw is removed.

(1) Remove four nuts (1), lockwashers (2), ground wire (3), and four screws (4). Remove trailer electrical connector (5) and spring cover (6) from mounting bracket (7).

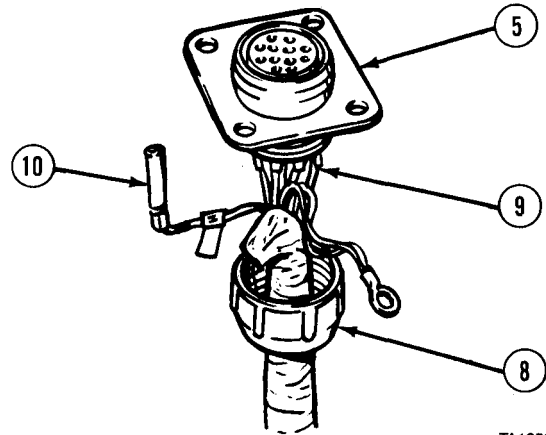
Electrical System Maintenance Instructions (Cont)

- (2) Loosen nut (8) from back of trailer electrical connector (5).

NOTE

Tag and mark wires before removing.

- (3) Remove wires (9) with pins (10) from trailer electrical connector (5).



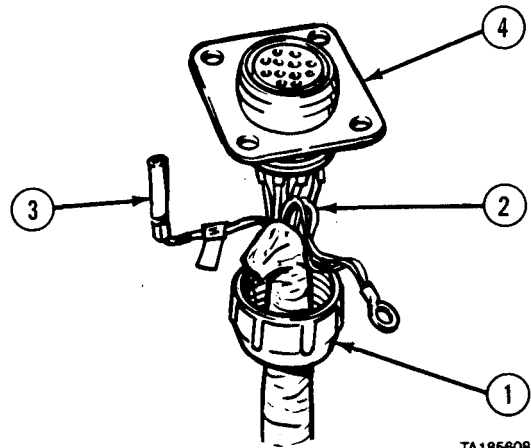
TA185607

b. Installation.

NOTE

Install plastic cable ties as required.

- (1) Slide nut (1) on wires (2).
- (2) Install pins (3) in trailer electrical connector (4).



TA185608

Electrical System Maintenance Instructions (Cont)

7-103. TRAILER ELECTRICAL CONNECTOR REMOVAL/INSTALLATION (M983) (CONT).

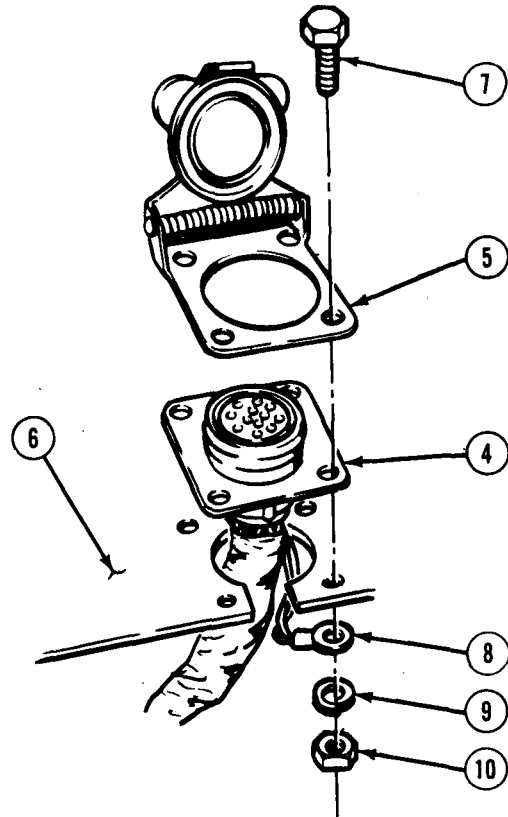
NOTE

Ground wire is installed on right-rear screw

- (3) Install spring cover (5) on trailer electrical connector (4).
- (4) Install trailer electrical connector (4) and spring cover (5) on mounting bracket (6) with four screws (7), ground wire (8), four lockwashers (9), and nuts (10).

c. Follow-on Maintenance. Connect batteries (para 7-91).

END OF TASK

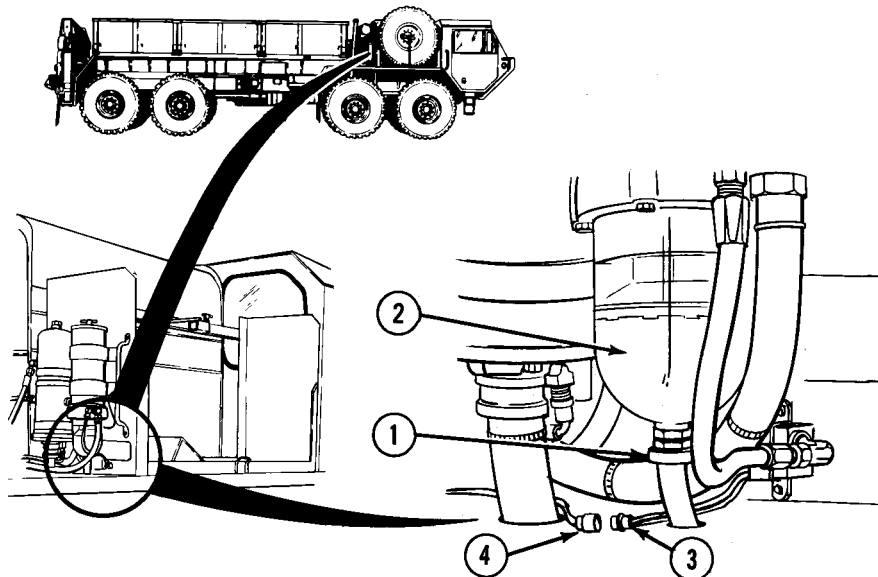


TA185609

| | |
|--|--|
| 7-104. FUEL RESTRICTION SENSOR REMOVAL/INSTALLATION. | |
| This task covers: | |
| a. Removal | c. Follow-on Maintenance |
| b. Installation | |
| INITIAL SETUP | |
| <i>Models</i> | <i>References</i> |
| All | None |
| <i>Test Equipment</i> | <i>Equipment Condition</i> |
| None | <i>TM or Para</i> <i>Condition Description</i> |
| <i>Special Tools</i> | TM 9-2320-279-10 Shut off engine. |
| None | <i>Special Environmental Conditions</i> |
| <i>Supplies</i> | None |
| Compound, sealing, pipe thread, Item 18, Appendix C | <i>General Safety Instructions</i> |
| Oil, fuel, diesel, Item 26, Appendix C | Wheels chocked. |
| <i>Personnel Required</i> | |
| MOS 63S, Heavy wheel vehicle mechanic | |

Electrical System Maintenance Instructions (Cont)

a. Removal.

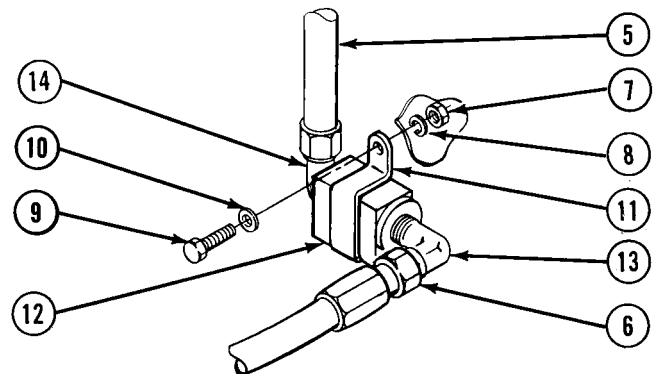


- (1) Open drain valve (1) and drain fuel from fuel-water separator (2).
- (2) Disconnect fuel restriction sensor wire (3) at sensor electrical plug (4).
- (3) Disconnect two hoses (5 and 6).

NOTE

Some vehicles have a nut, lockwasher, washer, and screw. Others have a flanged nut and screw.

- (4) Remove nut (7), lockwasher (8), screw (9), washer (10), clamp (11), and sensor (12).
- (5) Remove elbows (13 and 14).

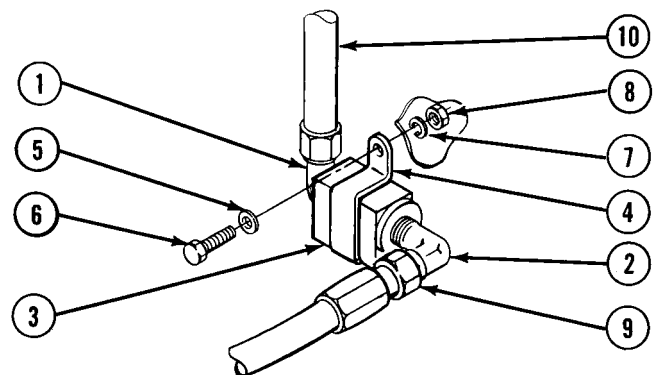


b. Installation.

WARNING

Adhesives, solvents, and sealing compounds can burn easily, can give off harmful vapors, and are harmful to skin and clothing. To avoid injury or death, keep away from open fire and use in well-ventilated area. If adhesive, solvent, or sealing compound gets on skin or clothing, wash immediately with soap and water.

- (1) Coat threads of elbows (1 and 2) with pipe thread sealing compound.
- (2) Install elbows (1 and 2) in sensor (3).



NOTE

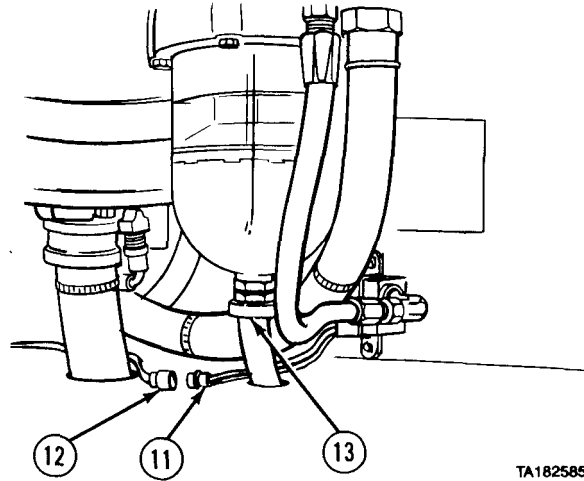
Some vehicles have a nut, lockwasher, washer, and screw. Others have a flanged nut and screw.

- (3) Attach sensor (3) to vehicle with clamp (4), washer (5), screw (6), lockwasher (7), and nut (8).
- (4) Connect hoses (9 and 10) to sensor (3).

Electrical System Maintenance Instructions (Cont)

7-104. FUEL RESTRICTION SENSOR REMOVAL/INSTALLATION (CONT).

- (5) Connect fuel restriction sensor wire (11) to sensor electrical plug (12).
- (6) Close drain valve (13).

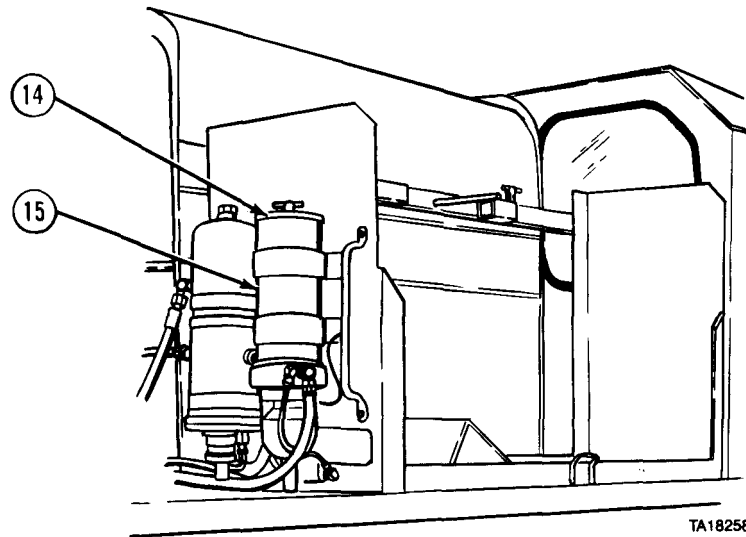


TA182585

- (7) Remove lid (14) from fuel-water separator (15).
- (8) Fill fuel-water separator (15) with fuel.
- (9) Install lid (14).

c. Follow-on Maintenance.

- (1) Start engine (TM 9-2320-279-10).
- (2) Check fuel lines and fittings for leaks.
- (3) Shut off engine (TM 9-2320-279-10).



TA182586

END OF TASK

Electrical System Maintenance Instructions (Cont)

7-105. CLEARANCE LIGHT WIRING HARNESS **REMOVAL/INSTALLATION (M977, M985).**

This task covers:

- a. Removal
- b. Installation

c. Follow-on Maintenance

INITIAL SETUP

Models

M977, M985

Test Equipment

None

Special Tools

None

Supplies

Connector, electrical, butt, Item 19,
Appendix C

Personnel Required

MOS 63S, Heavy wheel vehicle mechanic

References

None

Equipment Condition

TM or Para

Para 7-91

Condition Description

Disconnect batteries.

Special Environmental Conditions

None

General Safety Instructions

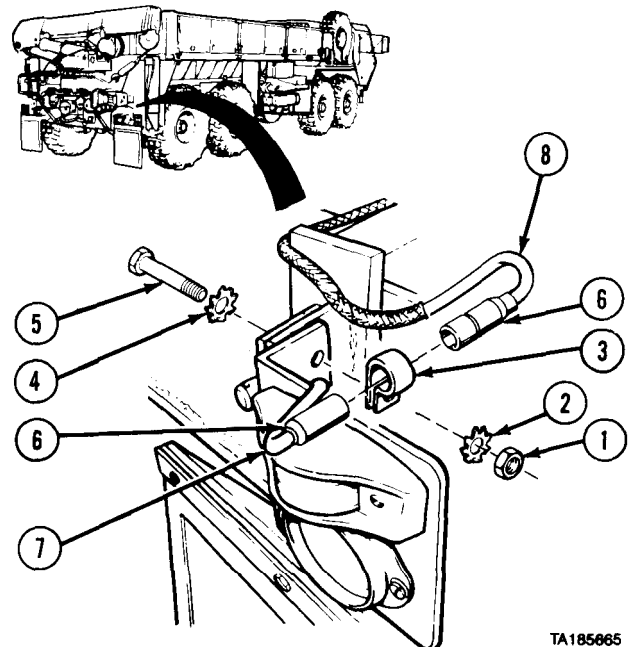
None

a. Removal.

NOTE

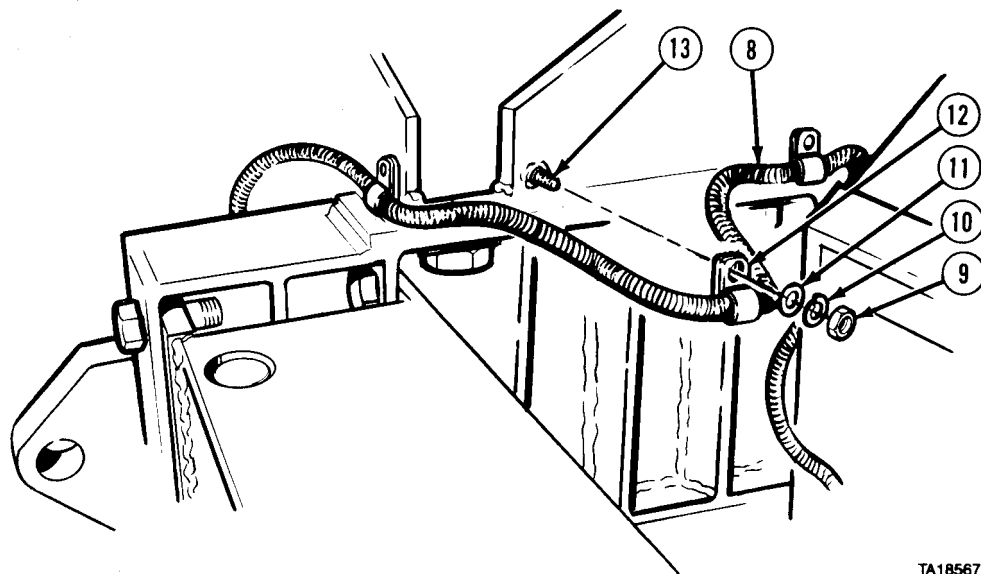
Left and right clearance light wiring harnesses are removed in the same manner.

- (1) Remove nut (1), lockwasher (2), cushion clip (3), lockwasher (4), and screw (5). Remove cushion clip from connectors (6).
- (2) Disconnect clearance light assembly wire (7) from clearance light wiring harness (8) at connector (6).



TA185065

7-105. **CLEARANCE LIGHT WIRING HARNESS REMOVAL/INSTALLATION (M977, M985)**
(CONT).

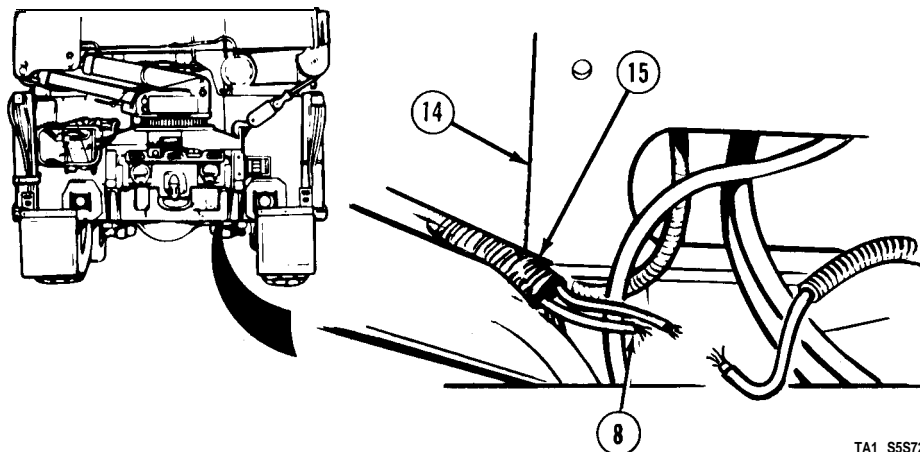


TA185671

NOTE

Two studs are under sub frame.

- (3) Remove five nuts (9), lockwashers (10), washers (11), cushion clips (12), and clearance light wiring harness (8) from subframe studs (13).



TA1 S5S72

- (4) Pull clearance light wiring harness (8) from under subframe (14).
 (5) Open loom (15) and cut clearance light wiring harness (8).

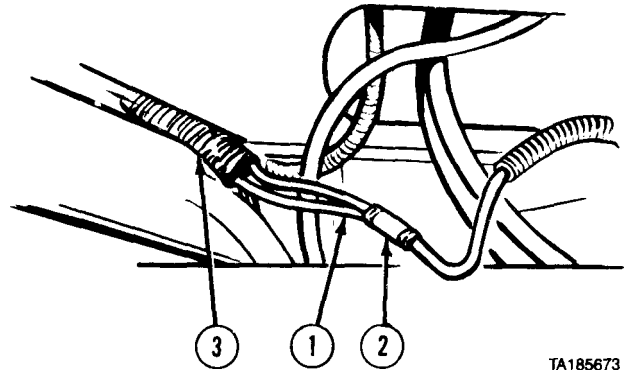
Electrical System Maintenance Instructions (Cont)

b. Installation.

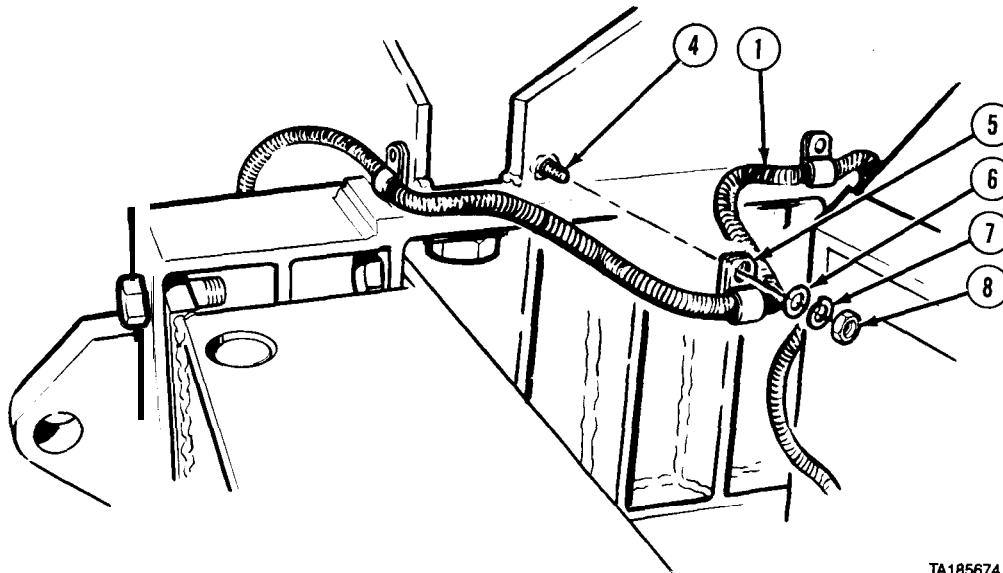
NOTE

Left and right clearance light wiring harnesses are installed in same manner.

- (1) Connect clearance light wiring harness (1) with electrical butt connector (2).
- (2) Close loom (3) over clearance light wiring harness (1).



TA185673



TA185674

NOTE

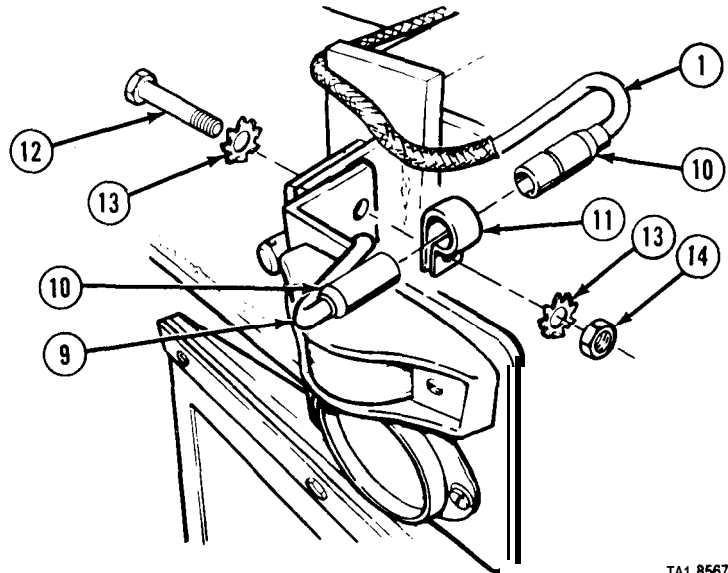
Two studs are under sub frame.

- (3) Install clearance light wiring harness (1) on five subframe studs (4) with cushion clips (5), washers (6), lockwashers (7), and nuts (8).

Electrical System Maintenance Instructions (Cent)

7-105. CLEARANCE LIGHT WIRING HARNESS **REMOVAL/INSTALLATION (M977, M985)**
(CONT).

- (4) Connect clearance light wiring harness (1) to clearance light assembly wire (9) at connectors (10).
 - (5) Install cushion clip (11) on connectors (10). Install cushion clip with screw (12), two lockwashers (13), and nut (14).
- c. Follow-on Maintenance.
- (1) Connect batteries (para 7-91).
 - (2) Check operation of clearance lights (TM 9-2320-279-10).



TA1 85675

END OF TASK

INDEX

| Subject | Paragraph, Figure, Table Number |
|--|---------------------------------------|
| A | |
| Adapter, engine oil filter removal/repair/installation | 3-5 |
| Adjuster, tank level indicator (M978) removal/installation/adjustment | 7-87 |
| Adjusting strap and alternator support removal/installation. | 7-4 |
| Adjustment | |
| Alternator belt | 6-14 |
| Definition of | 2-27 |
| ENGINE HIGH IDLE pressure regulator and solenoid (M984) | 4-15 |
| Engine stop solenoid | 4-8 |
| Fan belt | 6-16 |
| Headlight | 7-57 |
| Tank level indicator adjuster (M978) | 7-87 |
| Voltage regulator | 7-6 |
| Aim check, headlight | 7-57 |
| Air and oil pressure warning indicator light assembly removal/installation | 7-31 |
| Air cleaner assembly removal/installation | 4-5 |
| Air filter element removal/service/installation | 4-3 |
| Air intake ducting removal/installation | 4-4 |
| Air intake system, principles of operation | 1-16 |
| Air restriction indicator removal/installation | 4-2 |
| Air solenoid check valve, throttle (M984) removal/installation | 4-16 |
| Airsystem | |
| Principles of operation | 1-18 |
| Troubleshooting | 2-15 |
| Airventandfuellineremoval/installation | 4-6 |
| Alarmstat and water temperature sending unit removal/installation | 7-78 |
| Alternatorandpulleyremoval/installation | 7-3 |
| Alternator belt | |
| Adjustment | 6-14 |
| Removal/Installation | 6-15 |
| Alternator support and adjusting strap removal/installation | -7-4 |
| Alternator testing | 7-2 |
| Amberand red marker lights(M978) removal/installation | 7-74 |
| Ammeter removal/installation | 7-25 |
| Arctic heater kit, engine troubleshooting | 2-15 |
| Automatic transmission, principles of operation | 1-15 |
| Auxiliary pump junction box assembly (M978) removal/installation | 7-48 |
| B | |
| Baffle,radiatorremoval/installation | 6-4 |
| Baffle, side and bottom radiator removal/installation | 6-5 |
| Bar, bus removal/installation. | 7-15 |
| Batteries, terminals, and cables removal/service/installation | 7-90 |
| Battery box and NATO connector removal/repair/installation | 7-92 |
| Battery cables, negative connect/disconnect. | 7-91 |
| Beacon light assembly (M984E1) removal/repair/installation | 7-73.1 |
| Beacon light support brackets (M984E1) removal/installation | 7-73.2 |
| Belt, alternator | |
| Adjustment | 6-14 |
| Removal/Installation | 6-15 |
| Belt, fan | |
| Adjustment, | 6-16 |

INDEX (CONT)

| Subject | Paragraph, Figure, Table Number |
|--|---------------------------------------|
| Belt, fan (Cent) | |
| Removal/Installation | 6-17 |
| Blackout light assembly removal/installation | 7-68 |
| Blackout light lamp removal/installation | 7-69 |
| Block, junction removal/installation | 7-29 |
| Bottom radiator baffle, side and removal/installation | 6-5 |
| Box, auxiliary pump junction assembly (M978)removal/installation | 7-48 |
| Box, control (M984E1) removal/repair/installation | 7-52.1 |
| Box, control junction (M978) removal/installation | 7-49 |
| Box, ENGINE HIGH IDLE(M977, M985) removal/repair/installation | 7-10 |
| Box,,ENGINE HIGH IDLE, connectors and switches (tiredavit mounted) (M984, M985E1) Removal/Installation | 7-12 |
| Box, ENGINE HIGH IDLE, switches, bracket, and connector (crane mounted) (M984,M985E1)removal/installation | 7-11 |
| Box, main junction (M978) removal/installation | 7-47 |
| Box, outrigger switch (M984) removal/installation | 7-54 |
| Bracketand gage, TLI TANK LEVEL INDICATOR (M978) removal/installation | 7-86 |
| Bracketand work lamps(M984)removal/installation | 7-72 |
| Bracket, ENGINE HIGH IDLE box, connector, switches, and (crane mounted) (M984,M985E1)removal/installation | 7-11 |
| Bracket, mounting and front cab clearance lightassemblyremoval/installation | 7-64 |
| Bracket, sender mounting removal/installation | 7-17 |
| Brackets, clearance light, side and rear (M977, M984, M985) removal/installation | 7-67 |
| Brackets, fuel tank removal/installation | 4-7 |
| Brackets, side and rear clearance light(M977,M984,M985)removal/installation | 7-67 |
| Brake, engine, HIGH/LOW switch removal/installation | 7-39 |
| Brake, engine, indicator light removal/installation | 7-40 |
| Brake ON/OFF switch, engine removal/installation | 7-39 |
| Brake treadle valve stoplight switch removal/installation | 7-46 |
| Breaker, circuit, (center console) removal/installation | 7-43 |
| Breaker, circuit, rack and panel removal/installation | 7-44 |
| Breaker, engine circuit removal/installation | 7-14 |
| Busbarremoval/installation | 7-15 |
| Buzzersystemremoval/installation | 7-28 |
| C | |
| Cab, front, clearance lamp removal/installation | 7-63 |
| Cab, front, clearance light assembly and mounting bracket removal/installation | 7-64 |
| Cab, principles of operation | 1-26 |
| Cables, batteries, and terminals removal/service/installation | 7-90 |
| Cables, battery, negative connect/disconnect | 7-91 |
| Capabilities, characteristics, and features, equipment. | 1-11 |
| Center console circuit breaker removal/installation | 7-43 |
| Characteristics, capabilities, and features, equipment. | 1-11 |
| Check valve, throttle airsolenoid(M984) removal/installation | 4-16 |
| Circuit breaker, (center console) removal/installation | 7-43 |
| Circuit breaker, engine removal/installation , | 7-14 |
| Circuit breaker rack andpanelremoval/installation | 7-44 |
| Cleaning procedures | 2-21 |
| Clearance and identification light switch removal/installation | 7-39 |
| Clearance lamp, cab, front removal/installation | 7-63 |
| Clearance light assembly mounting bracket, cab, front removal/installation | 7-64 |
| Clearance light brackets, side and rear (M977, M984, M985) removal/installation | 7-67 |
| Clearance light wiring harness (M977, M985) removal/installation | 7-105 |

INDEX (CONT)

| Subject | Paragraph, Figure, Table Number |
|--|---------------------------------------|
| Clearance lights, pump module (M978) removal/installation | 7-75 |
| Clearance lights, rear (M984E1) removal/installation. | 7-67.2 |
| Clearance lights, rear side (M984E1) removal/installation | 7-67.1 |
| Clearance lights, side and rear (M977, M983, M984, M985) removal/installation. | 7-66 |
| Clearance rear, side, step, and side turn light removal/installation. | 7-65 |
| Clutch, fan removal/installation | 6-12 |
| Clutch to engine block hose, fan removal/installation | 6-13 |
| Common tools and equipment | 2-2 |
| Compartment lights, pump module (M978) removal/installation. | 7-76 |
| Components, vehicle | |
| Adjustment | 2-27 |
| Assembly | 2-25 |
| Disassembly | 2-23 |
| Inspection | 2-20 |
| Installation | 2-26 |
| Location and description. | 1-12 |
| Lubrication | 2-24 |
| Removal | 2-23 |
| Composite light assembly, front removal/installation | 7-61 |
| Composite light lamp, front and rear removal/installation. | 7-60 |
| Composite taillight assembly removal/installation | 7-62 |
| Conduittubing(M978)removal/installation | 7-53 |
| Connector, electrical, trailer (M983)removal/installation | 7-103 |
| Connector, NATO, and battery box, removal/repair/installation | 7-92 |
| Connector, switches, bracket, and ENGINE HIGH IDLE box (cranemounted) (M984, M985E1) removal/installation | 7-11 |
| Connectors, switches, and ENGINE HIGH IDLE box(tiredavit mounted) M984, M985E1) Removal/Installation | 7-12 |
| Console, center, circuit breaker removal/installation | 7-43 |
| Contact roller, horn switch removal/installation | 7-101 |
| Controlbox(M984E1)removal/repair/installation | 7-52.1 |
| Control indicator light assembly, traction removal/installation | 7-99 |
| Control junction box (M978) removal/installation | 7-49 |
| Controlvalve,fanremoval/installation | 6-10 |
| Cooler inlet elbow and flange elbow, oil removal/installation | 3-6 |
| Cooler, oil, housing removal/installation | 3-7 |
| Cooling system servicing | |
| Drain/fill cooling system | 6-2 |
| Maintenance | 6-1 |
| Principles of operation | 1-16 |
| Servicing | 6-2! |
| Cooling system draincocks, engine block | |
| Front draincock removal/installation. | 3-2 |
| Left side draincock removal/installation | 3-2 |
| Radiator draincock removal/installation | 3-2 |
| Right side draincock removal/installation | 3-2 |
| Cooling system hoses and tubes removal/installation | 6-7 |
| Cover, housing, and left thermostat, removal/installation | 6-8 |
| Cover, housing, and right thermostat, removal/installation | 6-9 |
| Crane operating instruction plate locations | 1-12 |
| Crane outrigger extended light assembly (M983, M984, M985E1) removal/installation | 7-95 |
| Crane, principles of operation. | 1-22 |
| Cross-reference, nomenclature | 1-5 |

INDEX (CONT)

| Subject | Paragraph, Figure, Table Number |
|---|---------------------------------------|
| D | |
| Reprocessing and unpacking | 2-6 |
| Destruction of army material to prevent enemy use..... | 1-2 |
| Differences between models, principal | 1-13 |
| Dimmer switch removal/installation | 7-102 |
| Dioderemoval/installation... | 7-16 |
| Disassembly of vehicle components general instructions. | 2-23 |
| Domelight assembly removal/installation | 7-70 |
| Domelight switch removal/installation | 7-39 |
| Drain cooling system | 6-2 |
| Draincocks, engine block cooling system | |
| Front draincock removal/installation | 3-2 |
| Left side draincock removal/installation | 3-2 |
| Radiator draincock removal/installation | 3-2 |
| Right side draincock removal/installation | 3-2 |
| Dual air brake system, troubleshooting | 2-15 |
| Ducting, air intake removal/installation | 4-4 |
| E | |
| EIR(Equipment Improvement Recommendations) reporting | 1-6 |
| Electric horn removal/installation | 7-89 |
| Electric horn relay removal/installation | 7-34 |
| Electrical connector, trailer(M983)removal/installation | 7-103 |
| Electrical system | |
| Maintenance | 7-1 |
| Principles of operation | 1-17 |
| Troubleshooting | 2-15 |
| Element, air filter removal/service/installation | 4-3 |
| Engine | |
| Description | 1-6 |
| Maintenance | 3-1 |
| Principles of operation | 1-16 |
| Troubleshooting | 2-15 |
| Engine arctic heater kit troubleshooting | 2-15 |
| Engine block cooling system draincocks | |
| Front draincock removal/installation | 3-2 |
| Left side draincock removal/installation | 3-2 |
| Radiator draincock removal/installation | 3-2 |
| Right side draincock removal/installation | 3-2 |
| Engine block hose-fan clutch removal/installation | 6-13 |
| Engine brake HIGH/LOW switch removal/installation | 7-39 |
| Engine brake indicator light removal/installation | 7-40 |
| Engine brake ON/OFF switch removal/installation | 7-39 |
| Engine circuit breaker removal/installation | 7-14 |
| Engine coolant, left thermostat, cover, and housing removal/installation | 6-8 |
| ENGINE HIGH IDLE box (M977, M985) removal/repair/installation | 7-10 |
| ENGINE HIGH IDLE box, connector, switches , and bracket (crane mounted) (M984, M985E1)removal/installation | 7-11 |
| ENGINE HIGH IDLE box, connectors, and switches (tire davit mounted)(M984, M985E1) Removal/Installation | 7-12 |
| ENGINE HIGH IDLE pressure regulator and solenoid (M984) Removal/Repair/Installation/Adjustment | 4-15 |
| Engineoilfilterremoval/repair/installation | 3-4 |
| Engineoilfilteradapterremoval/repair/installation | 3-5 |

INDEX (CONT)

| Subject | Paragraph, Figure, Table Number |
|--|---------------------------------------|
| Engine oil sampling valve removal/installation | 3-8 |
| Engine speed control assembly (M983) repair | 7-9 |
| Engine start switch removal/installation | 7-37 |
| Engine stop solenoid adjustment | 4-8 |
| Engine stop switch removal/installation | 7-38 |
| Equipment | |
| Characteristics, capabilities, and features | 1-11 |
| Description and data | 1-11 |
| Improvement recommendations (EIR), reporting | 1-6 |
| Improvement report and maintenance digest(EIRMD). | 1-7 |
| Improvement report and maintenance summary (FIR MS) | 1-7 |
| Name and model numbers. | 1-1 |
| Purpose | 1-1 |
| Ether start switch removal/installation | 7-100 |
| Ether starting aid removal/installation | 4-12 |
| Ether starting aid thermostat removal/installation | 7-77 |
| Exhaust system maintenance | 5-1 |
| F | |
| Fan removal/installation | 6-11 |
| Fan belt | |
| Adjustment | 6-16 |
| Removal/Installation | 6-17 |
| Fan clutch removal/installation | 6-12 |
| Fan clutch to engine block hose removal/installation | 6-13 |
| Fan control valve removal/installation | 6-10 |
| Fan shroud removal/installation | 6-6 |
| Fan switch, heater removal/installation | 7-42 |
| Features, characteristics, and capabilities, equipment | 1-11 |
| Fifth wheel (M983) troubleshooting | 2-15 |
| Fill cooling system | 6-2 |
| Filter adapter, engine oil, removal/repair/installation | 3-5 |
| Filter element, air removal/service/installation | 4-3 |
| Filter, engine oil removal/repair/installation | 3-4 |
| Filter, secondary fuel removal/installation | 4-11 |
| Fixed work lamp (M983, M984) repair | 7-73 |
| Fixed work lamp (M984E1) removal/installation | 7-72.1 |
| Flange elbow, oil cooler inlet elbow and removal/installation | 3-6 |
| Flasher relay removal/installation | 7-51 |
| Fluid leakage, types and causes | 2-12 |
| Forms and records, maintenance | 1-2 |
| Forms, maintenance | 2-10 |
| Front and rear axle tandems troubleshooting | 2-15 |
| Front and rear composite light lamp removal/installation | 7-60 |
| Front cab clearance lamp removal/installation | 7-63 |
| Front cab clearance light assembly and mounting bracket removal/installation | 7-64 |
| Front composite light assembly removal/installation | 7-61 |
| Front composite light lamp, and rear removal/installation | 7-60 |
| Front cooling system draincock removal/installation | 3-2 |
| Fuel filter, secondary removal/installation | 4-11 |
| Fuel gage removal/installation | 7-23 |
| Fuel level sensor (M978) removal/installation | 7-88 |
| Fuel line and air vent line (fuel tank) removal/installation | 4-6 |
| Fuel restriction sensor, STE/ICE removal/installation | 7-104 |

INDEX (CONT)

| Subject | Paragraph, Figure, Table Number |
|--|---------------------------------------|
| Fuel sending unit removal/installation | 7-80 |
| Fuel system | |
| Maintenance | 4-1 |
| Principles of operation | 1-16 |
| Troubleshooting | 2-15 |
| Fuel tank air ventline and fuel line removal/installation | 4-6 |
| Fuel tank and brackets removal/installation | 4-7 |
| Fuel-water separator | |
| Removal/Repair/Installation | 4-10 |
| Service | 4-9 |
| G | |
| Gage, fuel removal/installation | 7-23 |
| Gage, oil pressure removal/installation | 7-20 |
| Gage, TLI TANK LEVEL INDICATOR, and bracket (M978) removal/installation | 7-86 |
| Gage, transmission oil temperature removal/installation | 7-22 |
| Gage, water temperature removal/installation | 7-21 |
| Gasket, rocker cover removal/installation | 3-3 |
| General information | 1-1 |
| General maintenance procedures | 2-11 |
| Ground handling | 2-19 |
| H | |
| Hand receipt manual, reference | 2-7 |
| Harness, instrument panel removal/installation | 7-45 |
| Harness, PTO indicator light assembly, switch and removal/installation | 7-95 |
| Harness, wiring, clearance light (M977, M985) removal/installation | 7-105 |
| Hazards, significant, and safety recommendations | 1-14 |
| Headlight | |
| Adjustment | 7-57 |
| Aim check | 7-57 |
| Removal/Installation | 7-58 |
| Headlight assembly removal/installation | 7-59 |
| Heater, engine arctic kit troubleshooting | 2-15 |
| Heater fan switch removal/installation | 7-42 |
| Heavy-duty winch troubleshooting | 2-15 |
| High beam indicator light assembly removal/installation | 7-32 |
| HIGH IDLE box (M983)(See speed control assembly repair, engine) (M983) | 7-9 |
| HIGH IDLE box, ENGINE(M977, M985) removal/repair/installation | 7-10 |
| HIGH IDLE box, ENGINE, connector, switches, and bracket (crane mounted) (M984, M985E1) removal/installation | 7-11 |
| HIGH IDLE box, ENGINE, connectors, and switches (tire davit mounted) (M984, M985E1) | 7-12 |
| HIGH IDLE box, ENGINE(M978) (See control junction box) (M978) removal/installation | 7-49 |
| HIGH IDLE pressure regulator and solenoid, ENGINE | 4-15 |
| HIGH/LOW switch, engine brake removal/installation | 7-39 |
| Horn, electric removal/installation | 7-89 |
| Horn relay removal/installation | 7-34 |
| Horn switch contact roller removal/installation | 7-101 |
| Hose, fan clutch to engine block removal/installation | 6-13 |
| Hose, manifold, oil removal/installation | 7-83 |
| Hoses and tubes, cooling system removal/installation | 6-7 |
| Hourmeter oil pressure switch removal/installation | 7-82 |
| Hourmeter/tachometer removal/installation | 7-27 |
| Housing, cover, and left thermostat, removal/installation | 6-8 |

INDEX (CONT)

| Subject | Paragraph, Figure, Table Number |
|--|---------------------------------------|
| Housing, cover, and right thermostat, removal/installation. | 6-9 |
| Housing, oil cooler removal/installation. | 3-7 |
| How to use this manual | vii |
| Hydraulic system, principles of operation | 1-19 |
| Hydraulic system troubleshooting | 2-15 |
| I | |
| Identification and clearance light switch removal/installation | 7-39 |
| Ignition relay removal/installation | 7-33 |
| Illustrations, list of. | v |
| Indicator, air restriction removal/installation | 4-2 |
| INDICATOR gage and bracket, TLI TANK LEVEL (M978) removal/installation | 7-86 |
| Indicator light assembly, high beam removal/installation. | 7-32 |
| Indicator light assembly, switch, and harness, PTO removal/installation | 7-95 |
| Indicator light assembly, traction control removal/installation | 7-99 |
| Indicator light assembly, turn removal/installation., | 7-30 |
| Indicator light assembly, warning (oil and air pressure) removal/installation. | 7-31 |
| indicator light, engine brake removal/installation | 7-40 |
| Indicator, tank level, adjuster (M978) removal/installation/adjustment | 7-87 |
| Inlet elbow and flange elbow, oil cooler removal/installation | 3-6 |
| Inspection of vehicle components | 2-20 |
| Installation, definition of. | 2-26 |
| Installation of loose-shipped items. | 2-6 |
| Instruction plate locations, crane operating | 1-12 |
| Instrument panel removal/installation. | 7-19 |
| Instrument panel harness removal/installation. | 7-45 |
| Instrument panel receptacle removal/installation. | 7-36 |
| Intake ducting, air removal/installation. | 4-4 |
| Inventory of equipment. | 2-7 |
| J | |
| Junction block removal/installation | 7-29 |
| Junction box, auxiliary pump, (M978) removal/installation. | 7-40 |
| Junction box, control (M978) removal/installation | 7-49 |
| Junction box, main (M978) removal/installation. | 7-47 |
| K | |
| Kit, engine arctic heater troubleshooting | 2-15 |
| L | |
| Lamp, composite light, front and rear removal/installation. | T-GO |
| Lamp, front cab clearance removal/installation | 7-63 |
| Lamp, light, blackout removal/installation | 7-69 |
| Lamp, work, fixed (M984E1) removal/installation | 7-72.1 |
| Lamp, work, fixed (M983, M984, M984E1) repair | 7-73 |
| Lamp, work, removable (M983, M984, M984E1) repair | 7-73 |
| Lamp, work, removable (M964E1) removal/installation | 7-54.1 |
| Lamps, work (M983) removal/installation | 7-71 |
| Lamps, work, and bracket (M984) removal/installation. | 7-72 |
| Lamps, work, repair (M983, M984, M984E1). | 7-73 |
| Leakage, fluid, types and classes | 2-12 |
| Left side cooling system draincock removal/installation | 3-2 |
| Left thermostat, cover, and housing (engine coolant) removal/installation | 6-8 |
| Level indicator adjuster, tank (M978) removal/installation/adjustment | 7-87 |
| Level sensor, fuel (M978) removal/installation | 7-88 |
| LEVEL, TANK, INDICATOR gage and bracket, TLI (M978) removal/installation | 7-86 |

INDEX (CONT)

Paragraph,
Figure, Table
Number

Subject

| | |
|---|--------|
| Light assembly, blackout, removal/installation | 7-68 |
| Light assembly, crane outrigger extended (M983, M984, M985E1) removal/installation | 7-96 |
| Light assembly, high beam indicator removal/installation | 7-32 |
| Light assembly, mounting bracket, front cab clearance removal/installation | 7-64 |
| Light assembly, switch, and harness, PTO indicator removal/installation | 7-95 |
| Light assembly, traction control indicator removal/installation | 7-99 |
| Light assembly, turn indicator removal/installation | 7-30 |
| Light assembly, warning indicator removal/installation | 7-31 |
| Light brackets, side and rear clearance (M977, M984, M985) removal/installation | 7-67 |
| Light, clearance, wiring harness (M977, M985) removal/installation | 7-105 |
| Light, engine brake indicator removal/installation | 7-40 |
| Light, front composite assembly removal/installation | 7-61 |
| Light, lamp, blackout removal/installation | 7-69 |
| Light, lamp, front and rear composite removal/installation | 7-60 |
| Light, removable warning, repair | 7-55 |
| Light, side turn, side, step and rear clearance removal/installation | 7-65 |
| Light switch, clearance and identification removal/installation | 7-39 |
| Light switch, main removal/installation | 7-41 |
| Light switch, work (M983, M984) removal/installation | 7-39 |
| Light assembly, beacon (M984E1) removal/repair/installation | 7-73.1 |
| Light assembly, beacon, support brackets (M984E1) removal/installation | 7-73.2 |
| Light assembly, towing (M984E1) repair | 7-73.3 |
| Light, warning, removable repair | 7-55 |
| Lights, clearance, side and rear (M977, M983, M984, M985) removal/installation | 7-66 |
| Lights, clearance, rear (M984E1) removal/installation | 7-67.2 |
| Lights, clearance, rear side (M984E1) removal/installation | 7-67.1 |
| Lights, marker, red and amber (M978) removal/installation | 7-74 |
| Lights, pump module clearance (M978) removal/installation | 7-75 |
| Lights, pump module compartment (M978) removal/installation | 7-76 |
| List | |
| Of illustrations | V |
| Of tables | vi |
| Location and description of components | 1-12 |
| Loose-shipped items, installation of | 2-6 |
| Lubrication | 2-24 |
| M | |
| Magnetic switch removal/installation | 7-35 |
| Main junction box assembly (M978) removal/installation | 7-47 |
| Main light switch removal/installation | 7-41 |
| Maintenance | |
| Forms, records, and reports.. | 1-2 |
| Forms and records | 2-10 |
| Introduction | 2-17 |
| Procedures | 2-11 |
| Manifold, hose, oil removal/installation | 7-83 |
| Manifold, oil removal/installation | 7-13 |
| Manual | |
| How to use | vii |
| Type of manual | 1-1 |
| Marker lights, red and amber (M978) removal/installation | 7-74 |
| Marker lights, rear clearance (M984E1) removal/installation | 7-67.2 |
| Marker lights, rear side clearance (M984E1) removal/installation | 7-67.1 |
| Material handling cranes, troubleshooting | T 2-9 |

INDEX (CONT)

| Subject | Paragraph, Figure, Table Number |
|--|---------------------------------------|
| Metric system information | 1-9 |
| Model number and name of equipment | 1-1 |
| Module, pump, clearance lights (M978) removal/installation | 7-75 |
| Module, pump, compartment lights (M978) removal/installation | 7-76 |
| Module, resistor, STE/ICE removal/installation | 7-93 |
| Motor, starter | |
| Removal/Installation | 7-8 |
| Testing | 7-7 |
| Mounting bracket and front cab clearance light assembly removal/installation | 7-64 |
| Mounting bracket, sender removal/installation | 7-17 |
| Muffler assembly removal/installation | 5-2 |
| N | |
| NATO connector and battery box removal/repair/installation | 7-92 |
| NATO slave receptacle and box removal/repair/installation | 7-92.1 |
| Negative battery cables connect/disconnect | 7-91 |
| Neutral interlock switch sender unit removal/installation | 7-97 |
| Nomenclature cross-reference | 1-5 |
| O | |
| Odometer/Speedometer removal/installation | 7-26 |
| Oil and air pressure warning indicator light assembly removal/installation | 7-31 |
| Oil cooler housing removal/installation | 3-7 |
| Oil cooler inlet elbow and flange elbow removal/installation | 3-6 |
| Oil filter adapter, engine removal/repair/installation | 3-5 |
| Oil filter, engine removal/repair/installation | 3-4 |
| Oil manifold removal/installation | 7-13 |
| Oil manifold hose removal/installation | 7-83 |
| Oil pressure gage removal/installation | 7-20 |
| Oil pressure sending unit removal/installation | 7-79 |
| Oil pressure switch removal/installation | 7-84 |
| Oil pressure switch, hour meter removal/installation | 7-82 |
| Oil sampling valve, engine removal/installation | 3-8 |
| Oil temperature gage, transmission removal/installation | 7-22 |
| Oil temperature switch, transmission removal/installation | 7-85 |
| ON/OFF switch, engine brake removal/installation | 7-39 |
| Operating instruction plates, crane, locations | 1-12 |
| Optic ribbon assembly removal/installation | 7-56 |
| Outlet utility removal/installation | 7-18 |
| Outrigger extended light assembly, crane, (M983, M984, M985E I) removal/installation | 7-96 |
| Outrigger switch box (M984) removal/installation | 7-54 |
| P | |
| Painting | |
| Reference to instructions | 2-22 |
| Ship prior to storage preparation | 2-31 |
| Panel harness, instrument removal/installation | 7-45 |
| Panel, instrument removal/installation | 7-19 |
| Panel, rack, circuit breaker removal/installation | 7-44 |
| Panel receptacle, instrument removal/installation | 7-36 |
| Panels, side, switches removal/installation | 7-39 |
| Placing in service | 2-29 |
| Plate locations, crane operation instructions | 1-12 |
| PMCS | 2-9 |
| Power takeoff indicator light assembly, switch, and harness removal/installation | 7-95 |

INDEX (CONT)

| Subject | Paragraph, Figure, Table Number |
|---|---------------------------------------|
| Power train, principles of operation | 1-15 |
| Preparation | |
| For storage or shipment | 2-30 |
| Of vehicle, cleaning and painting for storage | 2-31 |
| Pressuregauge,oilremoval/installation | 7-20 |
| Pressure regulator solenoid, ENGINE HIGHIDLE(M984)removal/repair/installation | 4-15 |
| Pressuresendingunit,oilremoval/installation | 7-79 |
| Pressure switch, oil removal/installation | 7-84 |
| Pressure switch, oil,hourmeterremoval/installation | 7-82 |
| Prevent enemy use, destruction of army material | 1-3 |
| Preventive maintenance checksand services | |
| General maintenance procedures | 2-11 |
| Introduction | 2-9 |
| Maintenance formsand records | 2-10 |
| Tables 2-1 through 2-6 | 2-13 |
| Preventive maintenance checksand services (PMCS) -walk-around checks | |
| Auxiliary equipment | T 2-6 |
| M977 and M985 | T 2-2 |
| M977 through M985 | T 2-1 |
| M978 | T 2-3 |
| M983 | T 2-4 |
| M984 | T 2-5 |
| M984E1 | T 2-5.1 |
| Principal differences between models | 1-13 |
| Principles of operation | |
| Air intake system | 1-16 |
| Air system | 1-18 |
| Automatic transmission | 1-15 |
| Cooling system | 1-16 |
| Cranes | 1-22 |
| Electrical system | 1-17 |
| Engine | 1-16 |
| Fuel system | 1-16 |
| General | 1-1 |
| Hydraulics system | 1-19 |
| Power train | 1-15 |
| Propeller shafts and universaljoints | 1-15 |
| Recovery winch | 1-23 |
| Self-recovery winch | 1-21 |
| Steering system | 1-20 |
| 'lhdemaxlesandsuspension | 1-15 |
| Tanker (M978) | 1-27 |
| Transfer case | 1-15 |
| Propeller shaft and universal joints | |
| Principles of operation | 1-15 |
| Troubleshooting | 2-15 |
| PTO indicator light assembly, switch ,andharnessremoval/installation | 7-95 |
| PTO switch, harness, and indicator light assemblyremoval/installation | 7-95 |
| Pulley and alternator removal/installation | 7-3 |
| Pump, auxiliary, junction box assembly (M978)removal/installation | 7-48 |
| Pump module clearance lights (M978) removal/installation | 7-75 |
| -Pump module compartment lights (M978) removal/installation | 7-76 |
| Purpose of equipment | 1-1 |

INDEX (CONT)

| Subject | Paragraph, Figure, Table Number |
|---|---------------------------------------|
| R | |
| Rack and panel, circuit breaker removal/installation | 7-44 |
| Radiatorremoval/installation | 6-3 |
| Radiatorbaffleremoval/installation. | 6-4 |
| Radiator baffle, side and bottom removal/installation. | 6-5 |
| Radiator draincock removal/installation | 3-2 |
| Radio interference suppression | |
| Defined | 2-28 |
| System, testing | 2-28 |
| Rear and front composite lightlampremoval/installation | 7-60 |
| Rear and side clearance light brackets (M977, M984,M985)removal/installation. | 7-67 |
| Rear and side clearance lights (M977,M983,M984,M985)removal/installation | 7-66 |
| Rear composite light lamp, and frontremoval/installation | 7-60 |
| Rear, step, and side clearance, and side turn light removal/installation. | 7-65 |
| Rear clearance marker lights (M984El)removal/installation. | 7-67.2 |
| Rear side clearance marker lights (M984El)removal/installation | 7-67.1 |
| Reassembly of vehicle components, general instructions | 2-25 |
| Receipt of new vehicle, service | 2-29 |
| Receptacle, instrument panelremoval/installation. | 7-36 |
| Records, maintenance forms | 2-10 |
| Records, maintenance forms, and reports | 1-2 |
| Recovery winch, principles of operation | 1-23 |
| Red and ambermarkerlights (M978)removal/installation. | 7-74 |
| Regulator andsolenoid, pressure, ENGINE HIGH IDLE (M984) | |
| Removal/Repair/Installation/Adjustment. | 4-15 |
| Regulator, voltage | |
| Adjustment | 7-6 |
| Removal/Installation | 7-5 |
| Relay,flasherremoval/installation | 7-51 |
| Relay,hornremoval/installation | 7-34 |
| Relay,ignitionremoval/installation | 7-33 |
| Relay,starterremoval/installation | 7-94 |
| Removable warning light t-e-pair | 7-55 |
| Removable work lamps(M983, M984) repair | 7-73 |
| Removable work lamps(M984El) removal/installation | 7-54.1 |
| Removal and disassembly ofcomponents | 2-23 |
| Repair parts, special tools, test, measurement and diagnostic equipment | 2-5 |
| Reportingequipment improvement recommendations (EAR). | 1-6 |
| Reports, maintenance forms, records and | 1-2 |
| Resistormodule,STE/ICEmoval/installation. | 7-93 |
| Restriction indicator, air removal/installation | 4-2 |
| Restriction sensor, fuel removal/installation | 7-104 |
| Retarder, engine brake (See engine brake) | Index 4 |
| Retrieval system (M984El) | 1-24 |
| Ribbon assembly, optic removal/installation | 7-56 |
| Right side cooling system draincock removal/installation | 3-2 |
| Right thermostat, cover, and housing (engine coolant) removal/installation | 6-9 |
| Rockercoverandgasketremoval/installation. | 3-3 |
| Roller, horn switch contact removal/installation. | 7-10: |
| S | |
| Safety, care, and handling. | 1-14 |
| Safety recommendations, significant hazards and | 1-14 |
| Secondary fuel filter removal/installation | 4-11 |
| Self-recovery winch | |
| Principles ofoperation | 1-21 |

INDEX (CONT)

| Subject | Paragraph, Figure, Table Number |
|--|---------------------------------------|
| Self-recovery winch (Cent) | |
| Troubleshooting | 2-15 |
| Sender mounting bracket removal/installation | 7-17 |
| Sender unit, neutral interlock switch removal/installation | 7-97 |
| Sendingunit,fuelremoval/installation | 7-80 |
| Sendingunit,oilpressureremoval/installation | 7-79 |
| Sendingunit,speedometerremoval/installation | 7-81 |
| Sending unit, tachometer removal/installation | 7-98 |
| Sending unit water temperature, and alarmstatremoval/installation. | 7-78 |
| Sensor,fuellevel(M978)removal/installation. | 7-88 |
| Sensor, fuel restriction, STE/ICE removal/installation | 7-104 |
| Separator, fuel-water | |
| Removal/Repair/Installation. | 4-10 |
| Service | 4-9 |
| Service | |
| Cooling system | 6-2 |
| Fuel-water separator | 4-9 |
| Vehicle before operation | 2-8 |
| Service vehicle uponreceipt. | 2-8 |
| Servicing vehicle | 2-18 |
| Shipment, preparation forstorage instructions | 2-31 |
| Shipment, preparation forstorage reference | 1-4 |
| Shroud, fan removal/installation | 6-6 |
| Side and bottom radiatorbaffleremoval/installation | 6-5 |
| Side and rear clearance light brackets (M977,M984,M985)removal/installation | 7-67 |
| Side and rear clearance lights (M977,M983,M984,M985)removal/installation | 7-66 |
| Side rear clearance lights (M984E1) removal/installation. | 7-67.1 |
| Side panel switches removal/installation | 7-39 |
| Side, step, and rear clearance, and side turnlightremoval/installation | 7-65 |
| Signal switch, turn removal/installation | 7-50 |
| Significant hazardsandsafety recommendations | 1-14 |
| Slave receptacle (NATO) and box removal/repair/installation | 7-92.1 |
| Solenoid and ENGINE HIGH IDLE pressure regulatorremoval/repair/installation/adjustment | 4-15 |
| Solenoid check valve, throttle air(M984) removal/installation | 4-16 |
| Solenoid, engine stop, adjustment | 4-8 |
| Special tools, reference | 2-3 |
| Speed control assembly, engine (M983), repair | 7-9 |
| Speedometer/odometerremoval/installation. | 7-26 |
| Speedometersendingunitremoval/installation | 7-81 |
| Start switch, engine removal/installation | 7-37 |
| Start switch, ether removal/installation. | 7-100 |
| Starter motor | |
| Removal/Installation | 7-8 |
| Testing | 7-7 |
| Starterrelayremoval/installation. | 7-94 |
| Starting aid, ether removalhinstallation | 4-12 |
| Startingaidthermostat,etherremoval/installation | 7-77 |
| STE/ICE fuel restriction sensor removal/installation | 7-104 |
| STE/ICE introduction | 2-16 |
| STE/ICE resistor module removal/installation | 7-93 |
| Steering system | |
| Principles ofoperation | 1-20 |
| Troubleshooting | 2-15 |

INDEX (CONT)

| Subject | Paragraph, Figure, Table Number |
|--|---------------------------------------|
| Step, side, rear clearance, side turn light removal/installation | 7-65 |
| Stop solenoid, engine, adjustment | 4-8 |
| STOP switch, ENGINE removal/installation | 7-38 |
| Stoplight switch, brake treadle valve removal/installation | 7-46 |
| Storage | 2-33 |
| Storage or shipment, preparation for | 2-31 |
| Strap, alternator support and adjusting removal/installation | 7-4 |
| Support and adjusting strap, alternator removal/installation | 7-4 |
| Suspension troubleshooting. | 2-15 |
| Suspension and tandem axles, principles of operation | 1-15 |
| Switch box, outrigger(M984) removal/installation | 7-54 |
| Switch, brake treadle valve stoplight, removal/installation | 7-46 |
| Switch, clearance and identification light removal/installation. | 7-39 |
| Switch, dimmer removal/installation. | 7-102 |
| Switch, dome light removal/installation | 7-39 |
| Switch, engine start removal/installation | 7-37 |
| Switch, ENGINE STOP removal/installation | 7-38 |
| Switch, ether start removal/installation. | 7-100 |
| Switch, fan, heater removal/installation | 7-42 |
| Switch, harness, and PTO indicator light assembly removal/installation | 7-95 |
| Switch, HIGH/LOW, engine brake removal/installation | 7-39 |
| Switch, horn, contact roller removal/installation | 7-101 |
| Switch, identification light, clearance removal/installation. | 7-39 |
| Switch, light, main removal/installation | 7-41 |
| Switch, magnetic removal/installation | 7-35 |
| Switch, oil pressure removal/installation | 7-84 |
| Switch, oil pressure, hour meter removal/installation. | 7-82 |
| Switch, oil temperature, transmission removal/installation. | 7-85 |
| Switch, ON/OFF, engine brake removal/installation | 7-39 |
| Switch, PTO, harness, and indicator light assembly removal/installation | 7-95 |
| Switch sender unit, neutral interlock removal/installation | 7-97 |
| Switch, start, engine removal/installation | 7-37 |
| Switch, start, ether removal/installation | 7-100 |
| Switch, stop, engine removal/installation | 7-38 |
| Switch, stoplight, brake treadle valve removal/installation. | 7-46 |
| Switch, turn signal removal/installation | 7-50 |
| Switch, work light (M983, M984, M984E1) removal/installation | 7-39 |
| Switches and connectors, ENGINE HIGH IDLE box, (tire davit mounted) (M984, M985E1) Removal/Installation | 7-12 |
| Switches, bracket, and connector, ENGINE HIGH IDLE box, (crane mounted) (M984, M985E1) removal/installation | 7-11 |
| Switches, side panel, removal/installation | 7-39 |
| System, buzzer removal/installation. | 7-28 |
| T | |
| Tables, list of | vi |
| Tachometer/hour meter removal/installation | 7-27 |
| Tachometer sending unit removal/installation | 7-98 |
| Taillight assembly, composite removal/installation | 7-62 |
| Tandem axles and suspension, principles of operation | 1-15 |
| Tank and brackets, fuel removal/installation. | 4-7 |
| Tank level indicator adjuster (M978) removal/installation/adjustment | 7-87 |
| TANK LEVEL INDICATOR gage and bracket, TLI (M978) removal/installation | 7-86 |

INDEX (CONT)

| Subject | Paragraph, Figure, Table Number |
|---|---------------------------------------|
| Tanker (M978) | |
| Principles of operation | 1-27 |
| Troubleshooting | 2-15 |
| Tanker conduit tubing (M978) removal/installation | 7-53 |
| Temperature gage, transmission oil removal/installation | 7-22 |
| Temperature gage, water removal/installation | 7-21 |
| Temperature sending unit and alarmstat, water removal/installation | 7-78 |
| Temperature switch, transmission oil removal/installation | 7-85 |
| Terminals, batteries, and cables removal/service/installation | 7-90 |
| Test equipment (STE/ICE) location of | 2-4 |
| Testing | |
| Alternator | 7-2 |
| Starting motor | 7-7 |
| Throttle treadle valve | 4-13 |
| Thermostat, ether starting aid removal/installation | 7-77 |
| Thermostat, left, cover, and housing (engine coolant) removal/installation | 6-8 |
| Thermostat, right, cover, and housing (engine coolant) removal/installation | 6-9 |
| Throttle air solenoid check valve (M984) removal/installation | 4-16 |
| Throttle treadle valve | |
| Removal/Installation, | 4-14 |
| Testing | 4-13 |
| TLI TANK LEVEL INDICATOR gage and bracket (M978) removal/installation | 7-86 |
| Tools and equipment, common | 2-2 |
| Tools, special. | 2-3 |
| Torque, wheelnut | 2-13 |
| Tow light assembly (M984E1) repair | 7-73.3 |
| Traction control indicator light assembly removal/installation | 7-99 |
| Trailer electrical connector (M983) removal/installation | 7-103 |
| Transfer case | |
| Principles of operation | 1-15 |
| Troubleshooting | 2-15 |
| Transmission troubleshooting | 2-15 |
| Transmission, automatic, principles of operation | 1-15 |
| Transmission oil temperature gage removal/installation | 7-22 |
| Transmission oil temperature switch removal/installation | 7-85 |
| Treadle valve, brake, stoplight switch removal/installation | 7-46 |
| Treadle valve, throttle | |
| Removal/Installation | 4-14 |
| Testing | 4-13 |
| Troubleshooting instructions. | 2-15 |
| Troubleshooting introduction | 2-14 |
| Tubes and hoses, cooling system removal/installation | 6-7 |
| Tubing, conduit (M978) removal/installation | 7-53 |
| Turn indicator light assembly removal/installation | 7-30 |
| Turn signal switch removal/installation | 7-50 |
| Type of manual | 1-1 |
| U | |
| Unpacking and reprocessing. | 2-6 |
| Utility outlet removal/installation | 7-18 |
| V | |
| Valve, brake treadle, stoplight switch removal/installation | 7-46 |
| Valve, engine oil sampling removal/installation | 3-8 |
| Valve, fan control removal/installation | 6-10 |

INDEX (CONT)

| Subject | Paragraph, Figure, Table Number |
|--|--|
| Valve, throttle air solenoid check (M984) removal/installation | 4-16 |
| Valve, throttle treadle | |
| Removal/Installation | 4-14 |
| Testing | 4-13 |
| Vehicle description | 1-10 |
| Vehicle, inspect and service before operation | 2-8 |
| Vehicle preparation | 2-32 |
| Vehicle storage | 2-33 |
| Voltage regulator | |
| Adjustment | 7-6 |
| Removal/Installation | 7-5 |
| Voltmeterremoval/installation | 7-24 |
| W | |
| Warning indicator light assembly (oil and air pressure) removal/installation | 7-31 |
| Warning light, removable, repair | 7-55 |
| Warranty information | 1-8 |
| Watertemperaturegagerremoval/installation | 7-21 |
| Water temperature sending unit andalarmstatremoval/installation | 7-78 |
| Wheelsandtires | |
| Description | 1-25 |
| Troubleshooting | 2-15 |
| Winch, recovery, principles of operation | 1-23 |
| Winch, self-recovery, principles of operation | 1-21 |
| Wiring harness, clearance light (M977,M985)removal/installation | 7-105 |
| Worklamps(M983)removal/installation | 7-71 |
| Work lamps (M983, M984)repair | 7-73 |
| Worklamps(M984E1)removal/installation | 7-72.1 |
| Worklampsand bracket (M984) removal/installation | 7-72 |
| Worklight switch (M983, M984, M984E1) removal/installation. | 7-39 |

By Order of the Secretary of the Army:

JOHN A. WICKHAM, JR.
General, United States Army
Chief of Staff

Official:

R.L. DILWORTH
Brigadier General, United States Army
The Adjutant General

Distribution

To be distributed in accordance with DA Form 12-38, Truck, Cargo 10-Ton 8x8, Heavy Expanded Mobility Tactical Truck, HEMTT M977, M978, M983, M984, M985.

* U.S. GOVERNMENT PRINTING OFFICE : 1988 0 - 201-421 (71279)

RECOMMENDED CHANGES TO EQUIPMENT PUBLICATIONS



THEN - JOT DOWN THE INFO ON THIS FORM---TEAR OUT THIS PAGE---FOLD IT---AND DROP IT IN THE MAIL!

SOMETHING WRONG WITH THIS PUBLICATION?

FROM: (IMPRINT YOUR UNIT'S COMPLETE ADDRESS)

HQ & HQ CO.
46TH TRANS. BN.
FT. CARSON, CO

DATE SENT: 5 JAN., 1997

PUBLICATION NUMBER
TM 9-2320-279-20

PUBLICATION DATE
7 APRIL 1987

PUBLICATION TITLE
ORGANIZATIONAL MAINTENANCE MANUAL
M977 Series Vehicles

BE EXACT...PINPOINT WHERE IT IS

IN THIS SPACE, TELL WHAT IS WRONG AND WHAT SHOULD BE DONE ABOUT IT:

| PAGE NO. | PARA-GRAPH | FIGURE NO. | TABLE NO. |
|----------|------------|------------|-----------|
|----------|------------|------------|-----------|

| | | | |
|------|----|----|-----|
| 2-66 | NA | NA | 2-9 |
|------|----|----|-----|

Step (2) says:
Check water temperature gage for pump overheating.

Step (2) should say:
Check water temperature gage for engine overheating.

TEAR ALONG PERFORATED LINE

SAMPLE

PRINTED NAME, GRADE OR TITLE, AND TELEPHONE NUMBER
ALBERT RAND, SSG, 226-5644


SIGN HERE:
Albert Rand

DA FORM 1 JUL 79 2028-2

PREVIOUS EDITIONS ARE OBSOLETE.

P.S. IF YOUR OUTFIT WANTS TO KNOW ABOUT YOUR RECOMMENDATION, MAKE A CARBON COPY OF THIS AND GIVE IT TO YOUR HEADQUARTERS.

RECOMMENDED CHANGES TO EQUIPMENT PUBLICATIONS



THEN - JOT DOWN THE INFO ON THIS FORM---TEAR OUT THIS PAGE---FOLD IT---AND DROP IT IN THE MAIL

SOMETHING WRONG

WITH THIS PUBLICATION?

FROM: (IMPRINT YOUR UNIT'S COMPLETE ADDRESS)

DATE SENT:

PUBLICATION NUMBER
TM 9-2320-279-20-1

PUBLICATION DATE
7 APRIL 1987

PUBLICATION TITLE
ORGANIZATIONAL MAINTENANCE MANUAL
M977 Series Vehicles

| BE EXACT...PINPOINT WHERE IT IS | | | | IN THIS SPACE, TELL WHAT IS WRONG AND WHAT SHOULD BE DONE ABOUT IT: |
|---------------------------------|------------|------------|-----------|---|
| PAGE NO. | PARA-GRAPH | FIGURE NO. | TABLE NO. | |
| | | | | |

PRINTED NAME, GRADE OR TITLE, AND TELEPHONE NUMBER

SIGN HERE:

TEAR ALONG PERFORATED LINE

FILL IN YOUR
UNIT'S ADDRESS

FOLD BACK

TEAR ALONG PERFORATED LINE

DEPARTMENT OF THE ARMY

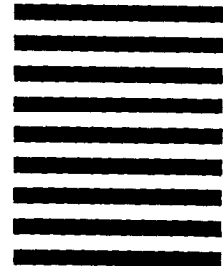


OFFICIAL BUSINESS

NO POSTAGE
NECESSARY
IF MAILED
IN THE
UNITED STATES

BUSINESS REPLY MAIL
FIRST CLASS BRM PERMIT NO. 82 ROCK ISLAND, IL

POSTAGE WILL BE PAID BY ROCK ISLAND ARSENAL



Director
Armament and Chemical Acquisition
and Logistics Activity
ATTN: AMSTA-AC-NML
ROCK ISLAND, IL 61201-9948



THE METRIC SYSTEM AND EQUIVALENTS

LINEAR MEASURE

1 Centimeter = 10 Millimeters = 0.01 Meters = 0.3937 Inches
 1 Meter = 100 Centimeters = 1000 Millimeters = 39.37 Inches
 1 Kilometer = 1000 Meters = 0.621 Miles

SQUARE MEASURE

1 Sq Centimeter = 100 Sq Millimeters = 0.155 Sq Inches
 1 Sq Meter = 10,000 Sq Centimeters = 10.76 Sq Feet
 1 Sq Kilometer = 1,003,000 Sq Meters = 0.386 Sq Miles

WEIGHTS

1 Gram = 0.001 Kilograms = 1000 Milligrams = 0.035 Ounces
 1 Kilogram = 1000 Grams = 2.2 Lb
 1 Metric Ton = 1000 Kilograms = 1 Megagram = 1.1 Short Tons

CUBIC MEASURE

1 Cu Centimeter = 1000 Cu Millimeters = 0.06 C. Inches
 1 Cu Meter = 1,000,000 C. Centimeters = 35.31 C. Feet

LIQUID MEASURE

1 Milliliter = 0.001 Liters = 0.0338 Fluid Ounces
 1 Liter = 1000 Milliliters = 33.82 Fluid Ounces

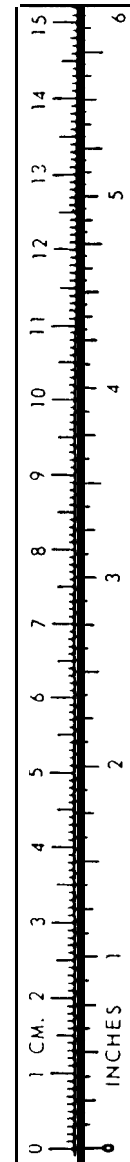
TEMPERATURE

59° F = 32° C
 212° Fahrenheit is equivalent to 100° Celsius
 90° Fahrenheit is equivalent to 32.2° Celsius
 32° Fahrenheit is equivalent to 0° Celsius
 $95 \text{ C}^{\circ} + 32 = \text{F}^{\circ}$

APPROXIMATE CONVERSION FACT(S)

| <u>TO CHANGE</u> | <u>TO</u> | <u>MULTIPLY BY</u> |
|----------------------------------|--------------------------------|--------------------|
| Inches | Centimeters | 2.540 |
| Feet | Meters | 0.305 |
| Yards | Meters | 0.914 |
| Miles | Kilometers | 1.609 |
| Square Inches | Square Centimeters | 6.451 |
| Square Feet | Square Meters | 0.093 |
| Square Yards | Square Meters | 0.836 |
| Square Miles | Square Kilometers | 2.590 |
| Acres | Square Hectometers | 0.405 |
| Cubic Feet | Cubic Meters | 0.028 |
| Cubic Yards | Cubic Meters | 0.765 |
| Fluid Ounces | Milliliters | 29.573 |
| Pints | Liters | 0.473 |
| Quarts | Liters | 0.946 |
| Gallons | Liters | 3.785 |
| Ounces | Grams | 28.349 |
| Pounds | Kilograms | 0.454 |
| Short Tons | Metric Tons | 0.907 |
| Pound-Feet | Newton-Meters | 1.356 |
| Pounds per Square Inch | Kilopascals | 6.995 |
| Miles per Gallon | Kilometers per Liter | 0.425 |
| Miles per Hour | Kilometers per Hour | 1.609 |

| <u>TO CHANGE</u> | <u>TO</u> | <u>MULTIPLY BY</u> |
|--------------------------------|----------------------------------|--------------------|
| Centimeters | Inches | 0.394 |
| Meters | Feet | 3.280 |
| Meters | Yards | 1.094 |
| Kilometers | Miles | 0.521 |
| Square Centimeters | Square Inches | 0.155 |
| Square Meters | Square Feet | 10.764 |
| Square Meters | Square Yards | 1.196 |
| Square Kilometers | Square Miles | 0.386 |
| Square Hectometers | Acres | 2.471 |
| Cubic Meters | Cubic Feet | 35.315 |
| Cubic Meters | Cubic Yards | 1.308 |
| Milliliters | Fluid Ounces | 0.034 |
| Liters | Pints | 2.113 |
| Liters | Quarts | 1.057 |
| Liters | Gallons | 0.264 |
| Grams | Ounces | 0.035 |
| Kilograms | Pounds | 2.205 |
| Metric Tons | Short Tons | 1.102 |
| Newton-Meters | Pound-Feet | 0.738 |
| Kilopascals | Pounds per Square Inch | 0.145 |
| Kilometers per Liter | Miles per Gallon | 2.354 |
| Kilometers per Hour | Miles per Hour | 0.621 |



PIN: 061591 – 005